

# HEAT CONTROLLER, INC.

## HYDRONIC AIR HANDLERS

The AHGV Series of air handlers is quiet, durable and economical to operate, with a blower motor that operates about 90% more efficiently than a PSC motor. The blower motor adjusts operating speed to deliver the proper airflow needed by the system.

By delivering constant CFM over a wide range of external static pressures in the system, the air handler provides improved air distribution, improved indoor air quality and enhanced comfort through continual dehumidification and reduced temperature stratification.

**AHRI matched to Heat Controller A/C Condensers to Achieve 13.5 to 15 SEER**

**Line Voltage Terminal Block and Low Voltage Terminal Strip**

Allows fast, simple thermostat connection

**R-410A Factory Installed TXV**  
For reliable refrigerant metering

**Slide-Out Blower Assembly**

Makes service and maintenance fast

**Freeze Protection for Both Heating & Cooling**

Protects the entire system year 'round

**3/4" Water Connections**

Assures correct water supply lines

## AHGV SERIES FOR R-410A

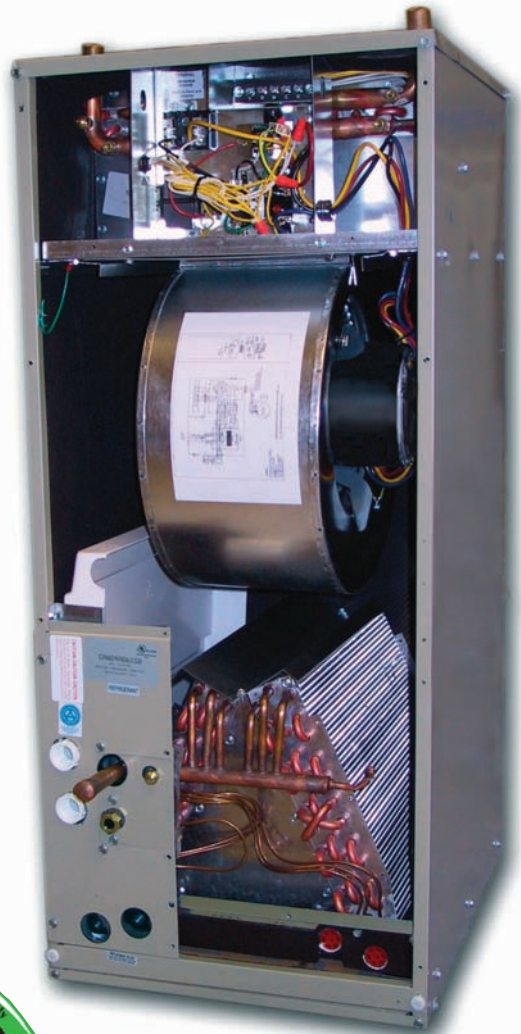

1 1/2 to 5 TONS

### CABINET FEATURES

- Entire cabinet is pre-painted, galvanized steel for maximum corrosion protection
- Interlocking access panels and gasketed screws eliminate air leakage

### EVAPORATOR COIL

- Aluminum fin/copper tube, TXV for R-410A
- Nylon non-corrosive drain pans
- Primary and secondary drains
- Limited 12 year warranty on coil (see pg. 4)

### HYDRONIC COIL

- Built-in coil design
- Aluminum fin/copper tube construction
- Manual air vent and drain valves
- 3/4" sweat water connections

### ELECTRIC SUPPLY

- 115V, 60 Hz system, 24 volt control circuit
- Low voltage terminal strip
- High voltage supply at top of cabinet
- Post-purge timer for cooling

## AHGV Series Hydronic Air Handlers—1½ to 5 Tons

The AHGV family of highly efficient Hydronic Air Handlers offers the most-wanted features in the industry:

- Low voltage terminal strip and 40VA 24 volt transformer included for easy wiring
- Blower time delay of two minutes preheats the hydronic coil to warm the air before blower turns on
- Freeze protection in both heat and cool modes provides the ultimate in system protection
- Constant airflow helps eliminate cold and hot spots for more even comfort
- Variable speed motor holds airflow constant under less than optimum duct configurations
- Variable speed blower pulls more humidity out of the air than single speed blowers
- Slide-out blower assembly makes service and maintenance fast and easy
- Multi-position design can be installed vertically or horizontally left or right (ships in upflow horizontal left configuration)
- Blower slowly ramps up to speed, eliminating abrupt changes in sound at start-up and shutdown; blower construction effectively reduces noise transmitted through the shaft

### PERFORMANCE

MODEL	TONS COOLING	REFRIGERATION CONN. SIZE		NOMINAL HEATING @ 180°F (BTUH)	NOMINAL AIRFLOW (CFM)	RECOMMENDED FILTER SIZE (in)	SHIPPING WEIGHT (lbs.)
		LIQUID (In. OD)	VAPOR				
AHGV24-0A	1.5	3/8	3/4	41,200	600	16 x 20 x 1	152
	2.0			41,200	800		
AHGV36-0A	2.5	3/8	3/4	62,500	1,000	16 x 20 x 1	152
	3.0			82,000	1,200		
AHGV48-0A	3.5	3/8	7/8	107,000	1,400	16 x 20 x 1	213
	4.0			107,000	1,600		
AHGV60-0A	5.0	3/8	7/8	125,000	1,800	16 x 20 x 1	213

### BLOWER PERFORMANCE DATA

MODEL	MOTOR @ 115V 60Hz		BLOWER WHEEL DIA.
	HP	AMPS	
AHGV24-0A	1/2	4.3	10 x 7
AHGV36-0A	1/2	4.3	10 x 7
AHGV48-0A	3/4	6.8	12 x 9
AHGV60-0A	3/4	6.8	12 x 9

BLOWER TAP	1/2 HP / AHGV 24/36			1 HP / AHGV 48/60		
	Ps	SCFM	AMPS	Ps	SCFM	AMPS
A	0.1	1422	1.690	0.1	1957	1.900
	0.2	1421	1.730	0.2	1919	1.900
	0.3	1421	1.790	0.3	1900	2.100
	0.4	1416	1.950	0.4	1871	2.300
	0.5	1415	2.030	0.5	1847	2.500
B	0.1	1215	1.020	0.1	1576	1.100
	0.2	1214	1.110	0.2	1565	1.200
	0.3	1214	1.190	0.3	1547	1.400
	0.4	1214	1.270	0.4	1517	1.500
	0.5	1208	1.390	0.5	1487	1.600
C	0.1	898	0.580	0.1	1495	0.800
	0.2	989	0.640	0.2	1482	0.900
	0.3	989	0.710	0.3	1451	1.100
	0.4	982	0.780	0.4	1432	1.200
	0.5	969	0.850	0.5	1409	1.200
D	0.1	865	0.900	0.1	1411	0.900
	0.2	865	1.000	0.2	1385	1.000
	0.3	865	1.200	0.3	1372	1.200
	0.4	864	1.300	0.4	1338	1.300
	0.5	858	1.400	0.5	1311	1.400

Blowers are factory pre-set at highest tap speed and can be field adjusted.

## EXTENDED RANGE DATA

(Based on entering water temperature and 65°F entering air temperature)

MODEL	HEATING NOMINAL SCFM	120°F	140°F	160°F	180°F	GPM	PRESSURE DROP
AHGV24	800	23,550	32,940	42,470	52,080	4	3.4
AHGV36	1200	28,900	40,530	52,340	64,310	4	3.5
AHGV48	1600	42,570	59,580	76,820	94,230	4	3.5
AHGV60	1800	52,790	73,740	94,920	116,270	7	5.1



ARI certification applies only when the complete system is listed with ARI

## EXTENDED RANGE DATA (based on water flow)

MODEL	BASED ON ENTERING WATER TEMP. AND 65°F ENTERING AIR TEMP.		
	2.0 GPM	4.0 GPM	7.0 GPM
AHGV24	43,320	52,080	N/A
AHGV36	50,730	64,310	N/A
AHGV48	N/A	94,230	109,040
AHGV60	N/A	99,180	116,270

## CONDENSER MATCHES FOR AHGV

CONDENSING UNIT	AIR HANDLER	NOMINAL TONS	SEER	EER	NOMINAL COOLING CAP. BTUH
RSG1318	AHGV24-0A	1.5	14.0	12.0	18,000
RSG1324	AHGV24-0A	2.0	14.0	11.8	23,800
RSG1330	AHGV36-0A	2.5	14.0	12.0	29,200
RSG1336	AHGV36-0A	3.0	14.0	12.0	36,000
RSG1342	AHGV48-0A	3.5	14.0	12.0	42,000
RSG1348	AHGV48-0A	4.0	14.0	12.0	48,000
RSG1360	AHGV60-0A	5.0	13.5	11.8	55,000
RSG1418	AHGV24-0A	1.5	15.0	13.5	18,000
RSG1424	AHGV24-0A	2.0	15.0	13.5	24,000
RSG1430	AHGV36-0A	2.5	15.0	13.0	30,000
RSG1436	AHGV36-0A	3.0	15.0	12.5	36,000
RSG1442	AHGV48-0A	3.5	15.0	12.5	41,000
RSG1448	AHGV48-0A	4.0	15.0	12.5	48,000
RSG1460	AHGV60-0A	5.0	14.5	12.5	59,000

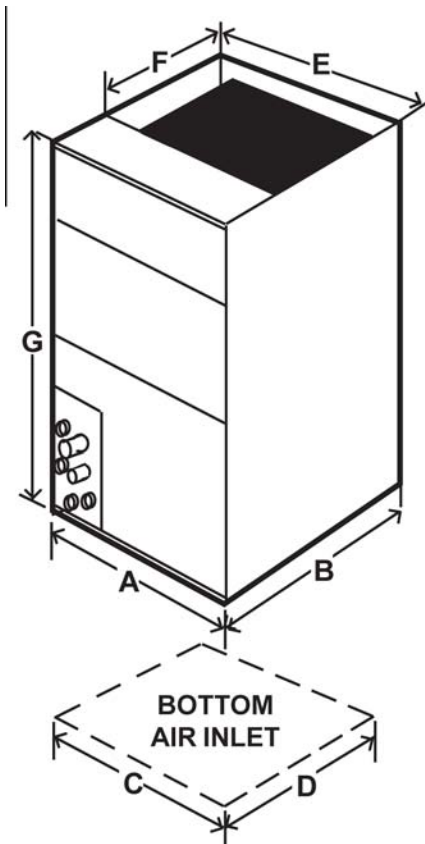

## DIMENSIONS (inches)

MODEL	A	B	C	D	E	F	G
AHGV24, AHGV36	21	21	19 <sup>3</sup> / <sub>4</sub>	20 <sup>1</sup> / <sub>4</sub>	19 <sup>7</sup> / <sub>8</sub>	14 <sup>3</sup> / <sub>4</sub>	48
AHGV48, AHGV60	24 <sup>1</sup> / <sub>2</sub>	21 <sup>1</sup> / <sub>2</sub>	23 <sup>3</sup> / <sub>8</sub>	20 <sup>1</sup> / <sub>2</sub>	19 <sup>5</sup> / <sub>8</sub>	16 <sup>1</sup> / <sub>8</sub>	58 <sup>3</sup> / <sub>4</sub>

Heat Controller has been in the business of keeping homes comfortable in all seasons since 1933. We offer a full line of energy efficient, quality constructed products including furnaces, heat pumps, air conditioners, dehumidifiers, ductless mini-split systems, and systems designed specially for geothermal installations. Our commercial/industrial line provides comfort solutions with capacities up to 25 tons. Each of the products in our line is backed by outstanding warranty coverage and after-sales support.

Your contractor or local dealer can help you select the equipment that is best suited to your needs and lifestyle.

..And for the best in year 'round comfort, AHGV air handlers are ideally matched with our 13 and 14 SEER condensing units for R-410A, available in a wide range of sizes and featuring the industry's best limited warranty—12 years on the compressor and 12 years on parts.

(With registration by original owner within 90 days of purchase and installed as part of an ARI matched system; other limitations apply. See printed limited warranty for details.)



*The AHGV Series of high efficiency air handlers comes charged with R-410A, an environmentally friendly refrigerant. Refrigerants used in the past contained chlorine which, when released to the atmosphere, combined with oxygen molecules from the earth's vital ozone layer, destroying this barrier that protects us from the sun's harmful ultraviolet rays. Soon all CFC and HCFC refrigerants used around the world will be replaced by non-ozone depleting types such as the R-410A already in use in our equipment.*

## HEAT CONTROLLER, INC.

1900 Wellworth Ave., Jackson, Michigan 49203 • Ph. 517-787-2100 • Fax 517-787-9341

THE QUALITY LEADER IN AIR CONDITIONING

[www.heatcontroller.com](http://www.heatcontroller.com)