

MB COMPACT HIGH-CAPACITY SERIES

# INSTALLATION, OPERATION & MAINTENANCE MANUAL

Part#: 97B0150N02 | Revised: March 25, 2026

Models: MB 072-300

60Hz – R-454B



Models:  
MB  
072-300

# Table of Contents

<b>3</b>	Model Nomenclature	<b>44</b>	Electrical Data
<b>4</b>	Attentions, Cautions, and Warnings	<b>44</b>	Standard
<b>6</b>	General Information	<b>46</b>	Dual Point Power
<b>9</b>	Minimum Installation Area	<b>48</b>	Electrical
<b>10</b>	Refrigerant System Servicing	<b>48</b>	Power and Low-Voltage Wiring
<b>13</b>	Physical Data	<b>49</b>	Example Wiring Diagram
<b>14</b>	Dimensional Data	<b>50</b>	Example VFD Wiring Diagram
<b>14</b>	MB072-120 Horizontal	<b>51</b>	VFD EMC and VAR Screws
<b>15</b>	MB072-120 with WSE Horizontal	<b>52</b>	Low-Voltage Wiring
<b>16</b>	MB072-120 Vertical	<b>53</b>	Thermostat Wiring
<b>17</b>	MB072-120 with WSE Vertical	<b>54</b>	External Pump Control
<b>18</b>	MB168-240 Vertical	<b>55</b>	Refrigerant Detection System
<b>19</b>	MB168-240 with WSE Vertical	<b>56</b>	CXM2, RDS, and Wireless Service Tool
<b>20</b>	MB300 Vertical	<b>57</b>	Blower Adjustment
<b>21</b>	MB300 with WSE Vertical	<b>58</b>	VFD Operation
<b>22</b>	Horizontal Installation	<b>61</b>	Tensioning V-Belt Drives
<b>23</b>	Service Access	<b>62</b>	Blower Sheave Information
<b>27</b>	Field Conversion of Air Discharge	<b>63</b>	Blower Performance
<b>30</b>	Vertical Installation	<b>85</b>	Operating Limits and Commissioning Conditions
<b>31</b>	Service Access	<b>86</b>	Piping System Cleaning and Flushing
<b>32</b>	Field Conversion of Air Discharge (072-120)	<b>87</b>	Unit and System Checkout
<b>34</b>	Field Conversion of Control Box (072-300)	<b>88</b>	Unit Startup Procedure
<b>35</b>	Field Conversion of Water Connections (072-240)	<b>91</b>	Unit Operating Conditions
<b>36</b>	Condensate Installation	<b>98</b>	Startup Log Sheet
<b>37</b>	Piping Installation	<b>101</b>	Troubleshooting
<b>38</b>	Applications	<b>101</b>	Troubleshooting Table
<b>38</b>	Water-Loop Heat Pump	<b>104</b>	Functional Troubleshooting Form
<b>39</b>	Ground-Loop Heat Pump Application	<b>105</b>	Warranty
<b>40</b>	Closed-Loop External Central Pumping	<b>108</b>	Revision History
<b>41</b>	Water Quality Requirements		

Heat Controller works continually to improve its products. As a result, the design and specifications of each product at the time of order may be changed without notice and may not be as described herein. Please contact Heat Controller's Customer Service Department at 517-787-2100 for specific information on the current design and specifications. Statements and other information contained herein are not express warranties and do not form the basis of any bargain between the parties, but are merely Heat Controller's opinion or commendation of its products.

# Model Nomenclature

1 | 2 | 3 | 4 | 5 | 6 | 7 | 8 | 9 | 10 | 11 | 12 | 13 | 14 | 15  
**M** | **B** | **L** | **O** | **7** | **2** | **B** | **K** | **C** | **3** | **0** | **C** | **0** | **1** | **S**

**PRODUCT NAME**

M = R-454B Refrigerant

**MODEL TYPE**

B = Compact High-Capacity Series

**SUPPLY/RETURN CONFIGURATION**

Horizontal		
Supply	Return	
	Left	Right
Straight	L	R
Back	B	P

Vertical	
Return/Supply	Option
Front/Top	F
Back/Top	C
Back/Front	G
Front/Back	H

**SIZE**

072	168 <sup>1</sup>
096	192 <sup>1</sup>
120	240 <sup>1</sup>
	300 <sup>1</sup>

**REVISION**

B = Current

**VOLTAGE**

3 Phase 60 Hz	With RDS
208/230	K
460	L
575	M

**CONTROLS**

Control	Standard	MPC
CXM2	C	N
CXM2 with Disconnect <sup>3</sup>	W	R

**STANDARD**

S = Standard

**BLOWER MOTOR**

	Belt Drive	Single-Point Power	Dual-Point Power
Standard Motor	Standard RPM	1	A
	Low RPM	2	B
	High RPM	3	C
Large Motor	Standard RPM	4	D
	High RPM	5	E
	VFD <sup>6</sup>	6	F

**EXTENDED OPTIONS<sup>5</sup>**

O = Standard, None  
W = Waterside Economizer

**DRAIN PAN/HEAT EXCHANGER OPTIONS**

C = Standard Drain Pan, Noncoated Air Coil  
S = Stainless-Steel Drain Pan, Noncoated Air Coil  
E = Standard Drain Pan, E-Coated Air Coil  
M = Stainless-Steel Drain Pan, E-Coated Air Coil

**WATER OPTIONS**

Horizontal				
Option	Coax			
	Copper		Cupronickel	
Water Side	Left	Right	Left	Right
None	0		1	
Vertical				
Option	Coax			
	Copper		Cupronickel	
Water Side	Left	Right	Left	Right
None	0	Z	1	2
MWV	M	V	3	4
MOD/MWV	C	N	5	6

**CABINET OPTIONS**

Cabinet	Sound Attenuation Package	Rail / Frame <sup>4</sup>		
		1"	2"	4"
Extended Range	No	1	J	Q
	Yes	2	L	T
Standard Range	No	3	N	U
	Yes	4	F	V

Notes:

1. Only available on Vertical configurations
2. 575V option not available for configurations with VFD
3. Disconnect control option not available on configurations with Dual-Point Power
4. Horizontal units come standard with filter rails; filter frames are field-installed accessories  
Vertical units come standard with filter frames
5. Waterside Economizer is only available for configurations with Extended Range cabinet  
Waterside Economizer is not available on Vertical Back-supply configurations
6. A VFD is required when the large motor option is specified on unit size 240

Models:  
MB  
072-300

# Attentions, Cautions, and Warnings

## SAFETY

Warnings, cautions, and notices appear throughout this manual. Read these items carefully before attempting any installation, service, or troubleshooting of the equipment.

**DANGER:** Indicates an immediate hazardous situation, which if not avoided will result in death or serious injury. DANGER labels on unit access panels must be observed.

**WARNING:** Indicates a potentially hazardous situation, which if not avoided could result in death or serious injury.

**CAUTION:** Indicates a potentially hazardous situation or an unsafe practice, which if not avoided could result in minor or moderate injury or product or property damage.

**NOTICE:** Notification of installation, operation, or maintenance information, which is important, but which is not hazard-related.

**WARNING**



Disconnect power supply(ies) before servicing. Refer servicing to qualified service personnel. Electric shock hazard. May result in injury or death!

**WARNING**

To avoid the release of refrigerant into the atmosphere, the refrigerant circuit of this unit must be serviced only by technicians who meet local, state, and federal proficiency requirements.

**WARNING**

The installation of water-source heat pumps and all associated components, parts, and accessories which make up the installation shall be in accordance with the regulations of ALL authorities having jurisdiction and MUST conform to all applicable codes. It is the responsibility of the installing contractor to determine and comply with ALL applicable codes and regulations.

**WARNING**

The appliance shall be stored in a room without continuously operating ignition sources (for example: open flames, an operating gas appliance or an operating electric heater).

**WARNING**

If an R-454B unit is connected to one or more rooms via an air duct system, and is installed in a room with an area less than  $A_{min}$  or has an Effective Dispersal Volume less than minimum, that room shall be without continuously operating open flames or other POTENTIAL IGNITION SOURCES. A flame-producing device may be installed in the same space if the device is provided with an effective flame arrest.

**WARNING**

All refrigerant discharged from this unit must be recovered WITHOUT EXCEPTION. Technicians must follow industry accepted guidelines and all local, state, and federal statutes for the recovery and disposal of refrigerants. If a compressor is removed from this unit, refrigerant circuit oil will remain in the compressor. To avoid leakage of compressor oil, refrigerant lines of the compressor must be sealed after it is removed.

**WARNING**

This appliance is not intended for use by persons (including children) with reduced physical, sensory, or mental capabilities, or lack of experience and knowledge, unless they have been given supervision or instruction concerning use of the appliance by a person responsible for their safety.

**WARNING**

An unventilated area where the appliance using FLAMMABLE REFRIGERANTS is installed shall be so constructed that should any refrigerant leak, it will not stagnate so as to create a fire or explosion hazard.

**WARNING**

Auxiliary devices which may be a POTENTIAL IGNITION SOURCE shall not be installed in the duct work. Examples of such POTENTIAL IGNITION SOURCES are hot surfaces with a temperature exceeding 1,292°F (700°C)

**WARNING**

An unventilated area where a water source heat pump is installed and surpasses a R-454B refrigerant charge of 62 oz (1.76 kg), shall be without continuously operating open flames (for example an operating gas appliance) or other POTENTIAL IGNITION SOURCES (for example, an operating electric heater, hot surfaces).

**WARNING**

Only auxiliary electric heaters approved by the manufacturer shall be installed in connecting ductwork. The installation of any other auxiliary devices is beyond the manufacturer's responsibility.

**WARNING**

For mechanical ventilation, the lower edge of the air extraction opening where air is exhausted from the room shall not be more than 3.94 inches (100 mm) above the floor. The location where the mechanical ventilation air extracted from the space is discharged shall be separated by a sufficient distance, but not less than 9.84 feet (3 m), from mechanical ventilation air intake openings, to prevent recirculation to the space.

**WARNING**

Children being supervised are NOT to play with the appliance.

**WARNING**

Do not pierce or burn.

**WARNING**

Be aware that refrigerants may not contain odor.

## Attentions, Cautions, and Warnings

### CAUTION

DO NOT store or install units in corrosive environments or in locations subject to temperature or humidity extremes (e.g., attics, garages, rooftops, etc.). Corrosive conditions and high temperature or humidity can significantly reduce performance, reliability, and service life. Always move and store units in an upright position. Tilting units on their sides will cause equipment damage.

### CAUTION

CUT HAZARD - Failure to follow this caution may result in personal injury. Sheet metal parts may have sharp edges or burrs. Use care and wear appropriate protective clothing, safety glasses and gloves when handling parts and servicing heat pumps.

### CAUTION

To avoid equipment damage, DO NOT use these units as a source of heating or cooling during the construction process. The mechanical components and filters can quickly become clogged with construction dirt and debris, which may cause system damage and void product warranty.

### CAUTION

All three phase scroll compressors must have direction of rotation verified at startup. Verification is achieved by checking compressor Amp draw. Amp draw will be substantially lower compared to nameplate values. Additionally, reverse rotation results in an elevated sound level compared to correct rotation. Reverse rotation will result in compressor internal overload trip within several minutes. Verify compressor type before proceeding.

### NOTICE

Servicing shall be performed only as recommended by the manufacturer.

### NOTICE

REFRIGERANT SENSORS for REFRIGERANT DETECTION SYSTEMS shall only be replaced with sensors specified by the appliance manufacturer.

### NOTICE

An unconditioned attic is not considered natural ventilation.

### NOTICE

This unit is equipped with electrically powered safety measures. To be effective, the unit must be electrically powered at all times after installation, other than when servicing.

### NOTICE

For Installation Only in Locations Not Accessible to the General Public.

### NOTICE

Maximum external statics must be adhered to in order to maintain minimum CFM.

### NOTICE

LEAK DETECTION SYSTEM installed. Unit must be powered except for service.

Models:  
MB  
072-300

## General Information

### INSPECTION

Upon receipt of the equipment, carefully check the shipment against the bill of lading. Make sure all units have been received. Inspect the packaging of each unit, and inspect each unit for damage. Ensure that the carrier makes proper notation of any shortages or damage on all copies of the freight bill and completes a common carrier inspection report. Concealed damage not discovered during unloading must be reported to the carrier within 15 days of receipt of shipment. If not filed within 15 days, the freight company can deny the claim without recourse.

**NOTE: It is the responsibility of the purchaser to file all necessary claims with the carrier. Notify your equipment supplier of all damage within 15 days of shipment.**

### STORAGE

Equipment should be stored in its original packaging in a clean, dry area. Store units in an upright position at all times. You may stack vertical configurations a maximum of two units high and horizontal configurations a maximum of three units high.

### UNIT PROTECTION

Cover units on the job site with either the original packaging or an equivalent protective covering. Cap the open ends of pipes stored on the job site. In areas where painting, plastering, and/or spraying has not been completed, all due precautions must be taken to avoid physical damage to the units and contamination by foreign material. Physical damage and contamination may prevent proper startup and may result in costly equipment cleanup.

Examine all pipes, fittings, and valves before installing any of the system components. Remove any dirt or debris found in or on these components.

### PRE-INSTALLATION

Installation, Operation, and Maintenance instructions are provided with each unit. Horizontal equipment is designed for installation above false ceiling or in a ceiling plenum. Other unit configurations are typically installed in a mechanical room. The installation site chosen should include adequate service clearance around the unit. Before unit startup, read all manuals and become familiar with the unit and its operation. Thoroughly check the system before operation.

### PREPARE UNITS FOR INSTALLATION AS FOLLOWS:

1. Compare the electrical data on the unit nameplate with ordering and shipping information to verify that the correct unit has been shipped.
2. Keep the cabinet covered with the original packaging until installation is complete and all plastering, painting, etc. is finished.
3. Verify refrigerant tubing is free of kinks or dents and that it does not touch other unit components.
4. Inspect all electrical connections. Connections must be clean and tight at the terminals.
5. Remove any blower support packaging (water-to-air units only).
6. Some airflow patterns are field convertible (horizontal units only). Locate the airflow conversion section of this IOM.

### CHECKS TO THE AREA

Prior to beginning work on systems containing FLAMMABLE REFRIGERANTS, safety checks are necessary to ensure that the risk of ignition is minimized. For repair to the REFRIGERATING SYSTEM, these steps shall be completed prior to conducting work on the system.

## General Information

### Work Procedure

Work shall be undertaken under a controlled procedure so as to minimize the risk of a flammable gas or vapor being present while the work is being performed.

### General Work Area

All maintenance staff and others working in the local area shall be instructed on the nature of work being carried out. Work in confined spaces shall be avoided.

### Checking for Presence of Refrigerant

The area shall be checked with an appropriate refrigerant detector prior to and during work, to ensure the technician is aware of potentially toxic or flammable atmospheres. Ensure that the leak detection equipment being used is suitable for use with all applicable refrigerants, i.e. non-sparking, adequately sealed or intrinsically safe.

### Presence of Fire Extinguisher

If any hot work is to be conducted on the refrigeration equipment or any associated parts, appropriate fire extinguishing equipment shall be available to hand. Have a dry powder or CO<sub>2</sub> fire extinguisher adjacent to the charging area.

### No Ignition Sources

No person carrying out work in relation to a REFRIGERATION SYSTEM which involves exposing any pipe work shall use any sources of ignition in such a manner that it may lead to the risk of fire or explosion. All possible ignition sources, including cigarette smoking, should be kept sufficiently far away from the site of installation, repairing, removing and disposal, during which refrigerant can possibly be released to the surrounding space. Prior to work taking place, the area around the equipment is to be surveyed to make sure that there are no flammable hazards or ignition risks. "No Smoking" signs shall be displayed.

### Ventilated Area

Ensure that the area is in the open or that it is adequately ventilated before breaking into the system or conducting any hot work. A degree of ventilation shall continue during the period that the work is carried out. The ventilation should safely disperse any released refrigerant and preferably expel it externally into the atmosphere.

### Checks to the Refrigeration Equipment

The following checks shall be applied to installations using FLAMMABLE REFRIGERANTS:

- The actual REFRIGERANT CHARGE is in accordance with the room size within which the refrigerant containing parts are installed
- The ventilation machinery and outlets are operating adequately and are not obstructed
- If an indirect refrigerating circuit is being used, the secondary circuit shall be checked for the presence of refrigerant
- Marking to the equipment continues to be visible and legible. Markings and signs that are illegible shall be corrected
- Refrigerant piping or components are installed in a position where they are unlikely to be exposed to any substance which may corrode refrigerant containing components, unless the components are constructed of materials which are inherently resistant to being corroded or are suitably protected against being so corroded

### Checks to Electrical Devices

Repair and maintenance to electrical components shall include initial safety checks and component inspection procedures. If a fault exists that could compromise safety, then no electrical supply shall be connected to the circuit until it is satisfactorily dealt with. If the fault cannot be corrected immediately but it is necessary to continue operation, an adequate temporary solution shall be used. This shall be reported to the owner of the equipment so all parties are advised.

Initial safety checks shall include:

- Capacitors are discharged: this shall be done in a safe manner to avoid possibility of sparking
- That no live electrical components and wiring are exposed while charging, recovering, or purging the system
- That there is continuity of earth bonding

Models:  
MB  
072-300

## General Information

### REPAIR TO INTRINSICALLY SAFE COMPONENTS

Intrinsically safe components must be replaced.

### CABLING

Check that cabling will not be subject to wear, corrosion, excessive pressure, vibration, sharp edges or any other adverse environmental effects. The check shall also take into account the effects of aging or continual vibration from sources such as compressors or fans.

### REQUIRED AREA FOR INSTALLATION

The minimum room area of the space ( $A_{min}$ ) or a minimum room area of conditioned space ( $TA_{min}$ ) shall be corrected for unit's location altitude by multiplying  $A_{min}$  or  $TA_{min}$  by the applicable altitude adjustment factor (AF) for building ground-level altitude ( $H_{alt}$ ) in feet or meters, as shown in the **Altitude Adjustment** table.

**NOTE:**

- You can use Imperial or Metric measurements to calculate  $A_{min}$  or  $TA_{min}$ .
- The maximum allowable altitude of installation for this product is 6,561 ft (2,000 m).

**Table 1: Altitude Adjustment**

H <sub>alt</sub> ft (m)	AF
0 (0)	1.00
656 (200)	1.00
1,312 (400)	1.00
1,968 (600)	1.00
2,624 (800)	1.02
3,280 (1,000)	1.05
3,937 (1,200)	1.07
4,593 (1,400)	1.10
5,249 (1,600)	1.12
5,905 (1,800)	1.15
6,561 (2,000)	1.18

# Minimum Installation Area

## MINIMUM INSTALLATION AREA

### Minimum area where a blower-equipped unit must be installed, and mechanical/natural ventilation is not required

Model	Charge (oz)	Configuration	Minimum Installation Area ft <sup>2</sup> (m <sup>2</sup> ) [A <sub>min</sub> ]			
			Floor	Window	Wall	Ceiling
MB072	54	Vertical	186	70	46	40
		Horizontal	186	70	46	40
MB096	62	Vertical	213	80	53	46
		Horizontal	213	80	53	46
MB120	66	Vertical	227	85	57	49
		Horizontal	213	80	53	46
MB168	94	Vertical	323	121	81	69
MB192	103	Vertical	354	133	89	76
MB240	134	Vertical	461	173	115	99
MB300	184	Vertical	633	237	158	136

A<sub>min</sub> = Minimum area where unit is installed where unit has incorporated airflow

h<sub>inst</sub> (floor) = 0.0 ft (0.0 m)

h<sub>inst</sub> (window) = 3.3 ft (1.0 m)

h<sub>inst</sub> (wall) = 5.9 ft (1.8 m)

h<sub>inst</sub> (ceiling) = 7.2 ft (2.2 m)

### Minimum area and CFM requirements for the conditioned space

Model	Charge (oz)	Minimum CFM [Q <sub>min</sub> ]	
		TA <sub>min</sub> (ft <sup>2</sup> )	Q <sub>min</sub> (ft <sup>3</sup> /min)
MB072	54	2.77	91
MB096	62	3.18	105
MB120	66	3.38	112
MB168	94	4.82	159
MB192	103	5.28	174
MB240	134	6.87	227
MB300	184	9.43	311

TA<sub>min</sub> = Minimum conditioned area for venting leaked refrigerant

Q<sub>min</sub> = Minimum ventilation flow rate for conditioned space if space is less than TA<sub>min</sub>

### Minimum area of opening for natural ventilation

Model	Charge (oz)	A <sub>nv</sub> (in <sup>2</sup> )
MB072	54	98.70
MB096	62	105.76
MB120	66	109.12
MB168	94	130.22
MB192	103	136.31
MB240	134	155.48
MB300	184	182.19

A<sub>nv</sub> = Minimum natural ventilation area opening

When the openings for connected rooms or natural ventilation are required, apply the following conditions:

- The area of any openings above 11.8 inches (300 mm) from the floor shall not be considered in determining compliance with Anv<sub>min</sub>.
- At least 50% of the required opening area Anv<sub>min</sub> shall be below 7.8 inches (200 mm) from the floor.
- The bottom of the lowest openings shall not be higher than the point of release when the unit is installed and not more than 3.9 inches (100 mm) from the floor.
- Openings are permanent openings which cannot be closed.
- For openings extending to the floor, the height shall not be less than 0.78 inch (20 mm) above the surface of the floor covering.
- A second higher opening shall be provided. The total size of the second opening shall not be less than 50% of minimum opening area for Anv<sub>min</sub> and shall be at least 3.3 ft (1.5 m) above the floor.

# Refrigerant System Servicing

## REFRIGERANT SYSTEM

To maintain sealed circuit integrity, do not install service gauges unless unit operation appears abnormal. Reference the operating charts for pressures and temperatures. Verify that air and water flow rates are at proper levels before servicing the refrigerant circuit.

### Removal and Evacuation

When breaking into the refrigerant circuit to make repairs - or for any other purpose - conventional procedures shall be used. However, for flammable refrigerants it is important that best practice be followed, since flammability is a consideration. The following procedure shall be adhered to:

- Safely remove refrigerant following local and national regulations
- Evacuate
- Purge the circuit with Inert gas
- Evacuate
- Continuously flush or purge with Inert gas when using flame to open circuit
- Open the circuit

The refrigerant charge shall be recovered into the correct recovery cylinders. For appliances containing flammable refrigerants, the system shall be purged with oxygen-free nitrogen to render the appliance safe. This process might need to be repeated several times. Compressed air or oxygen shall not be used for purging refrigerant systems.

For appliances containing flammable refrigerants, refrigerant purging shall be achieved by breaking the vacuum in the system with oxygen-free nitrogen and continuing to fill until the working pressure is achieved, then venting to atmosphere, and finally pulling down to a vacuum (optional for FLAMMABLE REFRIGERANT). This process shall be repeated until no refrigerant remains in the system (optional for FLAMMABLE REFRIGERANT). When the final oxygen-free nitrogen charge is used, the system shall be vented down to atmospheric pressure to enable work to take place.

The outlet for the vacuum pump shall not be close to any potential ignition sources, and ventilation shall be available.

### Charging Procedures

In addition to conventional charging procedures, the following requirements shall be followed:

- Ensure that contamination of different refrigerants does not occur when using charging equipment
- Hoses or lines shall be as short as possible to minimize the amount of refrigerant contained in them
- Cylinders shall be kept in an appropriate position according to the instructions
- Ensure that the REFRIGERATION SYSTEM is earthed prior to charging the system with refrigerant
- Label the system when charging is complete (if not already)
- Extreme care shall be taken not to overfill the REFRIGERATION SYSTEM

Prior to recharging the system, it shall be pressure-tested with the appropriate purging gas. The system shall be leak-tested on completion of charging but prior to commissioning. A follow up leak test shall be carried out prior to leaving the site.

### Leak Detection

Under no circumstances shall potential sources of ignition be used in the searching for or detection of refrigerant leaks. A halide torch (or any other detector using a naked flame) shall not be used.

The following leak detection methods are deemed acceptable for all refrigerant systems.

Electronic leak detectors may be used to detect refrigerant leaks but, in the case of FLAMMABLE REFRIGERANTS, the sensitivity may not be adequate, or may need re-calibration. Detection equipment shall be calibrated in a refrigerant-free area. Ensure that the detector is not a potential source of ignition and is suitable for the refrigerant used. Leak detection equipment shall be set at a percentage of the lower flammability limit of the refrigerant and shall be calibrated to the refrigerant employed, and the appropriate percentage of gas (25% maximum) is confirmed.

## Refrigerant System Servicing

Leak detection fluids are also suitable for use with most refrigerants but the use of detergents containing chlorine shall be avoided as the chlorine may react with the refrigerant and corrode the copper pipework.

### NOTE:

Examples of leak detection fluids are:

- Bubble method
- Fluorescent method agents

If a leak is suspected, all naked flames shall be removed/extinguished.

If a refrigerant leak that requires brazing is identified, all of the refrigerant shall be recovered from the system, or isolated (by means of shutoff valves) in a part of the system remote from the leak. Removal of refrigerant shall be according to Removal and Evacuation section.

## DECOMMISSIONING

Before carrying out this procedure, it is essential that the technician is completely familiar with the equipment and all its detail. It is recommended good practice that all refrigerants are recovered safely. Prior to the task being carried out, an oil and refrigerant sample shall be taken in case analysis is required prior to re-use of recovered refrigerant. It is essential that electrical power is available before the task is commenced.

1. Become familiar with the equipment and its operation
2. Isolate system electrically
3. Before attempting the procedure, ensure that:
  - Mechanical handling equipment is available, if required, for handling refrigerant cylinders
  - All personal protective equipment is available and being used correctly
  - The recovery process is supervised at all times by a competent person
  - Recovery equipment and cylinders conform to the appropriate standards

4. Pump down refrigerant system, if possible
5. If a vacuum is not possible, make a manifold so that refrigerant can be removed from various parts of the system
6. Make sure that cylinder is situated on the scales before recovery takes place
7. Start the recovery machine and operate in accordance with instructions
8. Do not overfill cylinders (no more than 80% volume liquid charge)
9. Do not exceed the maximum working pressure of the cylinder, even temporarily
10. When the cylinders have been filled correctly and the process completed, ensure that the cylinders and the equipment are removed from site promptly and all isolation valves on the equipment are closed off
11. Recovered refrigerant shall not be charged into another REFRIGERATING SYSTEM unless it has been cleaned and checked

**Labeling** - Upon decommissioning, equipment shall be labeled stating that it has been decommissioned and emptied of refrigerant. The label shall be dated and signed.

Models:  
MB  
072-300

## Refrigerant System Servicing

### RECOVERY

When removing refrigerant from a system, either for servicing or decommissioning, it is recommended good practice that all refrigerants are removed safely.

When transferring refrigerant into cylinders, ensure that only appropriate refrigerant recovery cylinders are employed. Ensure that the correct number of cylinders for holding the total system charge is available. All cylinders to be used are designated for the recovered refrigerant and labeled for that refrigerant (i.e. special cylinders for the recovery of refrigerant). Cylinders shall be complete with pressure-relief valve and associated shutoff valves in good working order. Empty recovery cylinders are evacuated and, if possible, cooled before recovery occurs.

The recovery equipment shall be in good working order with a set of instructions concerning the equipment that is at hand and shall be suitable for the recovery of the flammable refrigerant. If in doubt, the manufacturer should be consulted.

In addition, a set of calibrated weighing scales shall be available and in good working order. Hoses shall be complete with leak-free disconnect couplings and in good condition.

The recovered refrigerant shall be processed according to local legislation in the correct recovery cylinder, and the relevant waste transfer note arranged. Do not mix refrigerants in recovery units and especially not in cylinders.

If compressors or compressor oils are to be removed, ensure that they have been evacuated to an acceptable level to make certain that flammable refrigerant does not remain within the lubricant. The compressor body shall not be heated by an open flame or other ignition sources to accelerate this process. When oil is drained from a system, it shall be carried out safely.

# Physical Data

Models:  
MB  
072-300

## MB Physical Data

Standard Range Cabinet										
Configuration	Horizontal			Vertical						
Unit Size	072	096	120	072	096	120	168	192	240	300
Compressor Type	Scroll			Scroll						
Number of Circuits (Compressors)	2			2						
Refrigerant Leak Detection System	R	R	R	R	R	R	R	R	R	R
Number of Sensors	2	2	2	2	2	2	2	2	2	2
Factory Charge R-454B (oz) [kg] per Circuit	54 [1.5]	62 [1.8]	66 [1.9]	54 [1.5]	62 [1.8]	66 [1.9]	94 [2.7]	103 [2.9]	134 [3.8]	184 [5.2]
Blower Motor										
Standard Motor (hp) [kW]	1 [0.75]	2 [1.49]	3 [2.23]	1 [0.75]	2 [1.49]		3 [2.23]		5 [3.73]	7.5 [5.60]
Large Motor <sup>1</sup> (hp) [kW]	2 [1.49]	3 [2.23]	5 [3.73]	2 [1.49]	3 [2.23]		5 [3.73]		7.5 [5.60]	10 [7.46]
Water Connections										
FPT (in) [mm]	1-1/4" [31.8]		1-1/2" [38.1]	1-1/4" [31.8]		1-1/2" [38.1]	2" [50.8]		2-1/2" [63.5]	
Coax Data										
Number of Coaxes per Circuit	1			1			2		3	
Volume per Coax (gallon) [liter]	1.62 [6.13]	2.40 [9.08]	2.40 [9.08]	1.62 [6.13]	2.40 [9.08]	2.40 [9.08]	3.62 [13.70]	4.83 [18.28]	4.90 [18.55]	7.39 [27.98]
Condensate Connection Size										
FPT (in) [mm]	3/4" [19.1]			1" [25.4]						
Miscellaneous Data										
Filter Standard - 1" [2.54cm] Throwaway (qty) (in) [cm]	(QTY.3) 16 x 20 [40.6 x 50.8]			(QTY.4) 20 x 20 [50.8 x 50.8]			(QTY.4) 20 x 25 [50.80 x 63.5]			
	(QTY.1) 20 x 20 [50.8 x 50.8]						(QTY.2) 20 x 30 [50.80 x 76.2]			
Weight - Operating (lbs) [kg]	586 [265.8]	644 [292.1]	698 [316.6]	586 [265.8]	644 [292.1]	698 [316.6]	1069 [484.9]	1164 [528.0]	1184 [537.1]	1297 [588.3]
Weight - Packaged (lbs) [kg]	626 [283.9]	684 [310.3]	738 [334.8]	626 [283.9]	684 [310.3]	738 [334.8]	1149 [521.2]	1244 [564.3]	1264 [573.3]	1377 [624.6]
Corner Weights - Standard Configuration										
Compressor Section - Left Front (lb) [kg]	101 [46]	120 [52]	137 [62]							
Control Box - Right Front (lb) [kg]	235 [107]	254 [115]	271 [123]							
Air Coil Side - Back (lb) [kg]	70 [32]	80 [36]	90 [41]							
Blower Side - Back (lb) [kg]	180 [82]	190 [86]	200 [91]							
Extended Range Cabinet with Waterside Economizer										
Dimensions										
Standard Weight - Operating (lbs.) [kg]	586 [265.8]	644 [292.1]	698 [316.6]	586 [265.8]	644 [292.1]	698 [316.6]	1,069 [484.9]	1,164 [528.0]	1,184 [537.1]	1,297 [588.3]
Standard Weight - Packaged (lbs.) [kg]	626 [283.9]	684 [310.3]	738 [334.8]	626 [283.9]	684 [310.3]	738 [334.8]	1,149 [521.2]	1,244 [564.3]	1,264 [573.3]	1,377 [624.6]
WSE Unit Weight - Operating (lbs.) [kg]	838 [380.1]	921 [417.7]	998 [452.7]	762 [345.5]	837 [379.7]	907 [411.6]	1,529 [693.4]	1,665 [755]	1,693 [768]	1,855 [841.3]
WSE Unit Weight - Packaged (lbs.) [kg]	900 [408.2]	978 [443.7]	1,008 [457.2]	814 [369.1]	889 [403.3]	962 [436.4]	1,643 [745.3]	1,779 [806.9]	1,808 [819.9]	1,974 [895.4]
Air Coil Volume (gal) [L]	4.0 [15.1]	4.4 [16.7]		4.3 [16.3]	4.8 [18.2]		9.7 [36.7]		19.0 [71.9]	
Corner Weights										
Compressor Section - Left Front (lb) [kg]	154 [70]	169 [77]	183 [83]							
Control Box - Right Front (lb) [kg]	331 [150]	364 [165]	394 [179]							
Air Coil Side - Back (lb) [kg]	104 [47]	115 [52]	124 [56]							
Blower Side - Back (lb) [kg]	249 [113]	273 [124]	296 [134]							

• O = Optional, R = Required  
1. VFD Option comes with Large motor option

Models:  
MB  
072-300

# Dimensional Data MB072-120 Horizontal

Unit Size	Overall Cabinet			Discharge Connections Duct Flange				Water Connections			Electrical Knockouts				Return Air Connections Using Return Air Opening									
	A	B	C	D	E	F	G	K	L	M	O				Q		S		T	U	V			
	Width	Depth	Height	Side Offset	Supply Width	Supply Height	Supply Offset		Water Outlet	Water Inlet	1	2	1	2	3	4	1	2	Return Depth		Return Height	Unit Top Height		
											1-1/8" (2.9 cm)	7/8" (2.2 cm)	1-1/8" (2.9 cm)				7/8" (2.2 cm)		072	096-120				
072-120	inch	36.3	84.9	21.6	13.9	17.1	13.5	7.4	15.0	18.0	3.0	2.7	19.4	14.3	7.3	2.1	16.8	4.8	55.0	65.0	18.0	1.0	28.9	18.9
	cm	92.2	215.6	54.9	35.2	43.4	34.3	19.8	38.1	45.7	7.6	6.8	49.2	36.3	18.6	5.4	42.7	12.2	139.7	165.1	45.7	2.5	73.4	48.0

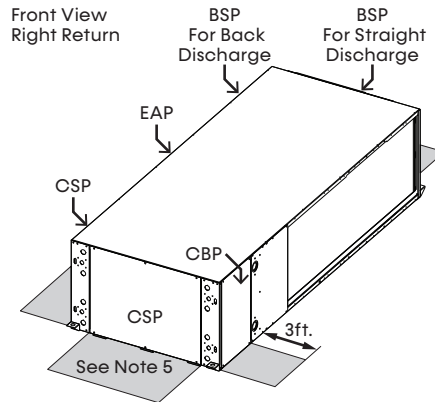
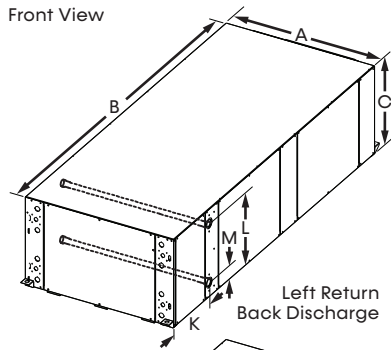

- NOTES**
- Water inlet and water outlet connections are field configurable on either side (left or right) of the unit.
  - Condensate drain is 3/4-inch FPT and is located on cabinet end opposite the compressor.
  - Electrical access is configurable on either side (left or right) of the front.
  - If the control box is configured on one side, it can be field converted to the opposite side. Conversion should only be attempted by a qualified service technician.
  - Units require 3 feet (90.1 cm) of clearance for water connections, CSP, CBP, EAP, and BSP service access. Service access is required at all removable panels locations and the installer should take care to comply with all building codes and allow adequate clearance for future field service.
  - Overall cabinet width dimensions do not include filter rail and duct flange.
  - Units are shipped with air filter rails that are not suitable for supporting return air ductwork. An air filter frame with duct mounting collar is available to order as an accessory.

- LEGEND**
- BSP = Blower Service Panel
  - CSP = Compressor Service Panel
  - CBP = Control Box Panel
  - EAP = Expansion Valve Access Panel

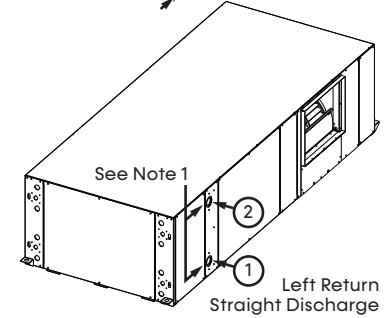

Legend	MB072-096	MB120
① Water Inlet <sup>1</sup>	1-1/4" FPT	1-1/2" FPT
② Water Outlet <sup>1</sup>	1-1/4" FPT	1-1/2" FPT
③ Condensate Drain <sup>2</sup>	1" FPT	
④ High Voltage Access <sup>3</sup>	1-3/8" (3.49 cm)	
⑤ Low Voltage Access <sup>3</sup>	7/8" (2.2 cm)	

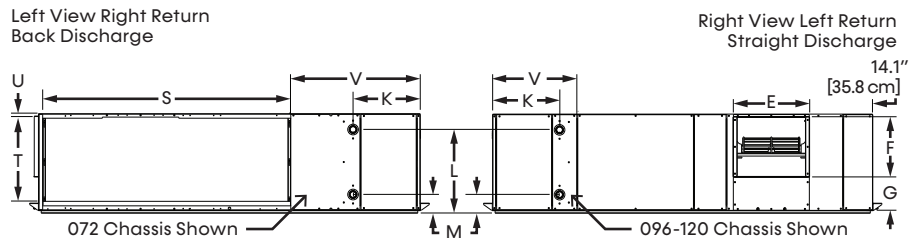
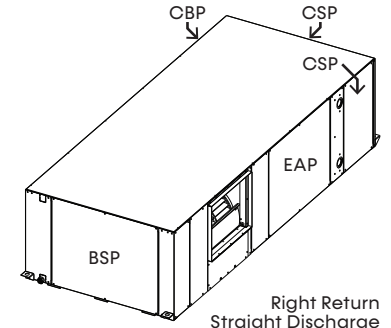
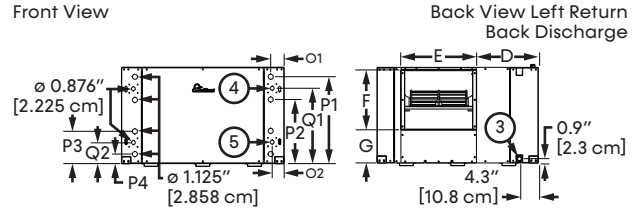
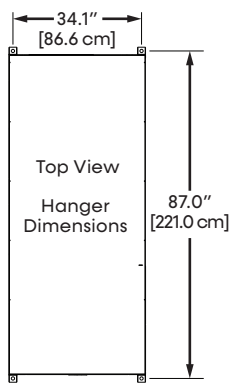
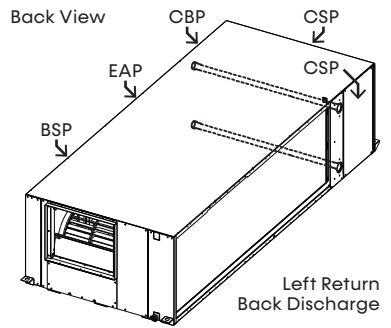

# Dimensional Data

## MB072-120 with WSE Horizontal

Models:  
MB  
072-300

Unit Size	Overall Cabinet			Discharge Connections Duct Flange				Water Connections			Electrical Knockouts						Return Air Connections Using Return Air Opening								
	A	B	C	D	E	F	G	K	L	M	O				Q		S		T	U	V				
	Width	Depth	Height	Side Offset	Supply Width	Supply Height	Supply Offset	1	2	1	2	P				1		2		Return Height	Unit Top Height	072	096-120		
												1	2	3	4	072	096-120								
072-120	inch	46.3	84.9	21.6	23.9	17.1	13.5	7.4	15.0	18.0	3.5	3.0	2.7	19.4	14.3	7.2	2.1	16.8	4.7	55.1	61.0	18.5	1.0	28.9	22.8
	cm	117.6	215.6	54.8	60.6	43.4	34.3	18.8	38.1	45.7	8.9	7.6	6.8	49.2	36.3	18.3	5.4	42.7	11.9	140.0	154.9	47.0	2.5	73.4	57.9

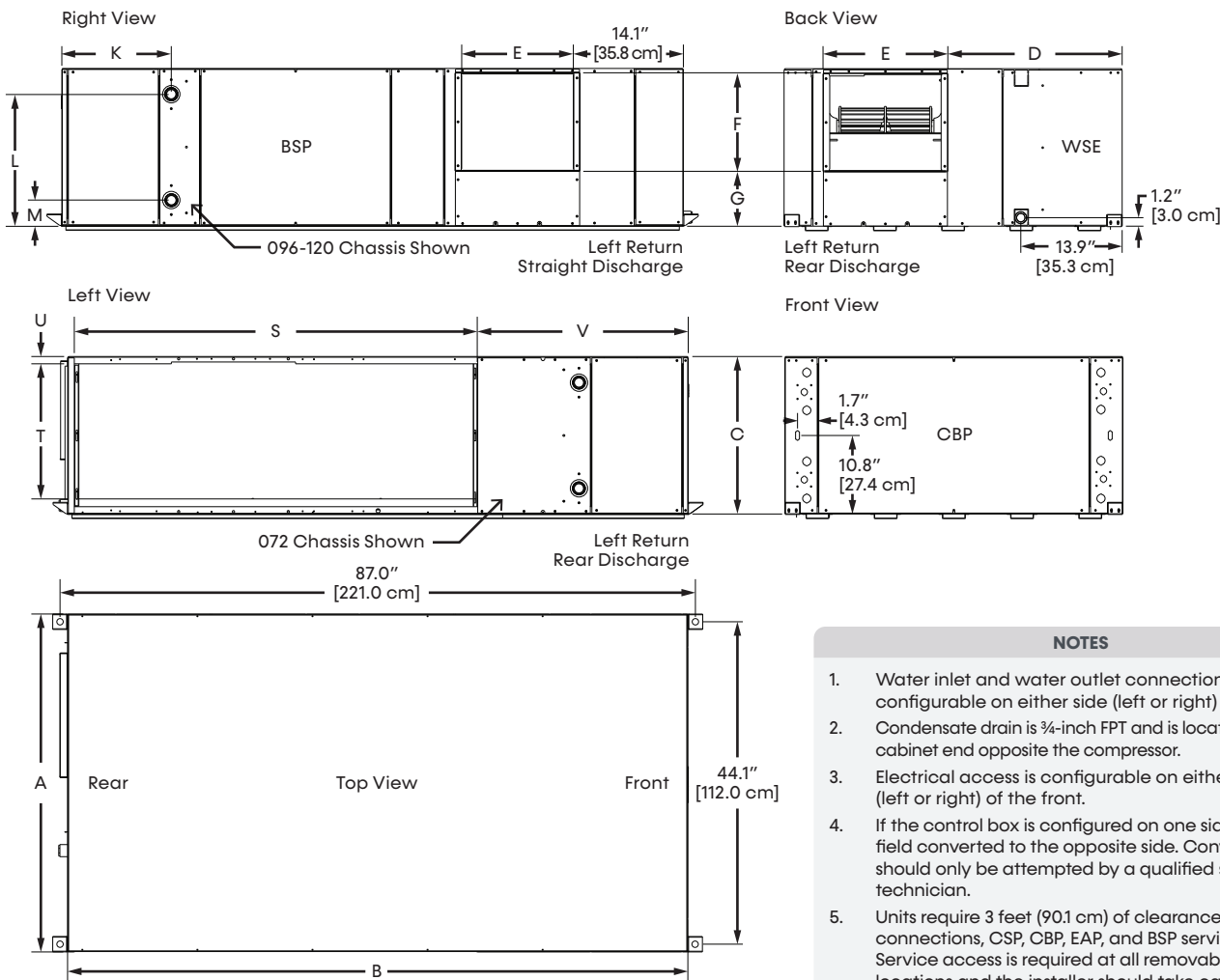

LEGEND	
<b>BSP</b>	= Blower Service Panel
<b>CSP</b>	= Compressor Service Panel
<b>CBP</b>	= Control Box Panel
<b>EAP</b>	= Expansion Valve Access Panel
<b>WSE</b>	= Waterside Economizer

- NOTES**
- Water inlet and water outlet connections are configurable on either side (left or right) of the unit.
  - Condensate drain is 3/4-inch FPT and is located on cabinet end opposite the compressor.
  - Electrical access is configurable on either side (left or right) of the front.
  - If the control box is configured on one side, it can be field converted to the opposite side. Conversion should only be attempted by a qualified service technician.
  - Units require 3 feet (90.1 cm) of clearance for water connections, CSP, CBP, EAP, and BSP service access. Service access is required at all removable panels locations and the installer should take care to comply with all building codes and allow adequate clearance for future field service.
  - Overall cabinet width dimensions do not include filter rail and duct flange.
  - Units are shipped with air-filter rails that are not suitable for supporting return air ductwork. An air filter frame with duct mounting collar is available to order as an accessory.

Models:  
MB  
072-300

# Dimensional Data MB072-120 Vertical

Unit Size	Overall Cabinet			Discharge Connections Duct Flange			Water Connections				Electrical Knockouts			Return Air Connections Using Return Air Opening						
	A	B	C	D	E	F	K	L	M	N	O			P	Q	S	T	U	V	
	Width	Depth	Height	Supply Width	Supply Height	Side Offset	1	2	3	Connection Height	1	2	3	7/8" (2.2 cm)	Return Width	Return Height				
							Water In	Water Out	Condensate		1-3/8" (3.5cm)									
072	inch	41.0	29.0	69.8	17.5	14.8	11.9	22.0	7.2	14.6	22.3	3.0	11.0	19.0	15.0	0.9	36.3	29.4	28.6	4.5
	cm	104.1	73.3	177.3	44.5	37.6	30.2	55.9	18.3	37.1	56.6	7.6	27.9	48.3	38.1	2.3	92.2	74.7	72.6	11.4
096-120	inch	41.0	29.0	69.8	17.5	14.8	11.9	22.0	7.2	14.6	22.3	3.0	11.0	19.0	15.0	0.9	36.0	35.1	28.6	2.6
	cm	104.1	73.3	177.3	44.5	37.6	30.2	55.9	18.3	37.1	56.6	7.6	27.9	48.3	38.1	2.3	91.4	89.2	72.6	6.6

**NOTES**

1. Condensate drain is available on either side (left or right) of unit. Drain hose and drain connection will be tied inside the unit. Installer will untie the drain hose, form trap, and connect to the condensate drain hole of installer's choice.
2. Electrical access is available on either side (left or right) of unit and is also available in the front on the left or right side of the unit.
3. Overall cabinet dimensions do not include duct flange or filter rails.
4. Units require 3 feet (90.1 cm) of clearance for water connections, CSP, CBP, MSP, and BSP service access. Service access is required at all removable panels locations and installer should take care to comply with all building codes and allow adequate clearance for future field service.
5. Filter removal is from right or left side of filter frame, allow 3 feet (61 cm) of access for servicing.

Front View Top Discharge

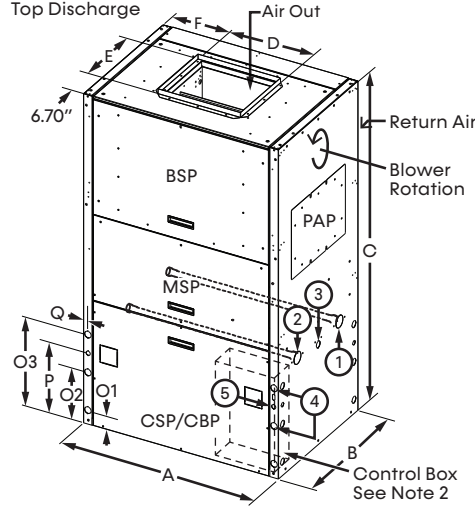

Rear View Top Discharge

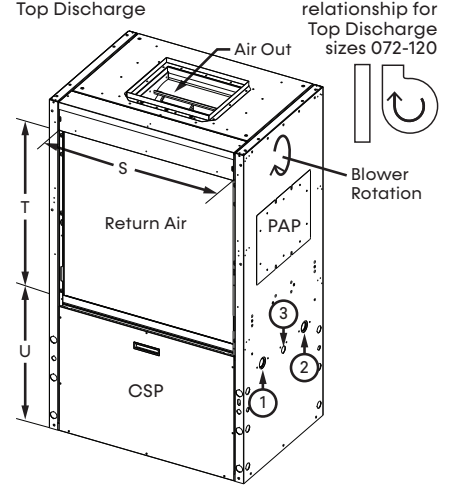

Front View Straight Discharge

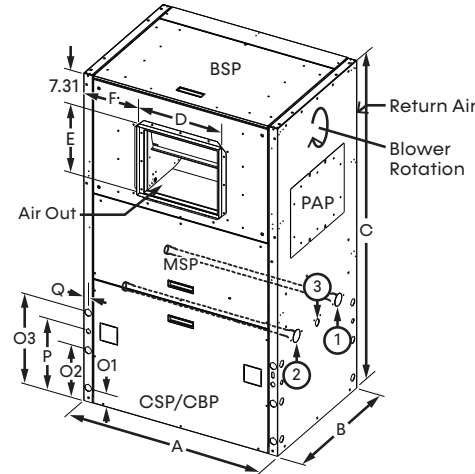

Rear View Straight Discharge

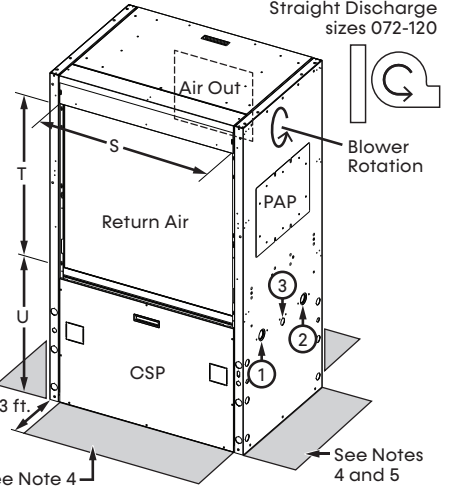

Right Side View Straight Discharge

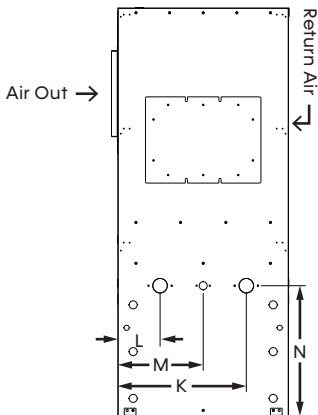

Notes	MB072-096	MB120
① Water Inlet <sup>1</sup>	1-1/4" FPT	1-1/2" FPT
② Water Outlet <sup>1</sup>	1-1/4" FPT	1-1/2" FPT
③ Condensate Drain <sup>2</sup>	1" FPT	
④ High Voltage Access <sup>3</sup>	1-3/8" (3.49 cm)	
⑤ Low Voltage Access <sup>3</sup>	7/8" (2.2 cm)	

**LEGEND**

- BSP = Blower Service Panel
- CBP = Control Box Panel
- CSP = Compressor Service Panel
- MSP = Motor Service Panel
- PAP = Pulley Access Panel

# Dimensional Data MB072-120 with WSE Vertical

Models:  
MB  
072-300

Unit Size		Overall Cabinet			Discharge Connections Duct Flange			Water Connections				Electrical Knockouts			Return Air Connections Using Return Air Opening					
		A	B	C	D	E	F	K	L	M	N	O	P	Q	S	T	U	V		
		Width	Depth	Height	Supply Width	Supply Height	Side Offset	1 Water In	2 Water Out	3 Condensate	Connection Height	1	2	3	Return Width	Return Height		Return Side Offset		
072	inch	41.3	39.2	69.8	17.5	14.7	11.9	22.0	7.2	14.6	22.3	3.0	11.0	19.0	15.1	0.9	34.0	31.6	28.6	3.6
	cm	104.9	99.6	177.3	44.5	37.3	30.2	55.9	18.3	37.1	56.6	7.6	27.9	48.3	38.4	2.3	86.4	80.3	72.7	9.1
096-120	inch	41.3	39.2	69.8	17.5	14.7	11.9	22.3	6.9	14.6	22.3	3.0	11.0	19.0	15.1	0.9	36.0	34.1	28.6	3.0
	cm	104.9	99.6	177.3	44.5	37.3	30.2	56.6	17.5	37.1	56.6	7.6	27.9	48.3	38.4	2.3	91.4	86.6	72.7	7.5

Top View  
Rear Return Front Discharge

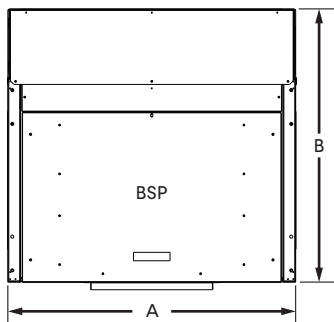

Top View  
Rear Return Top Discharge

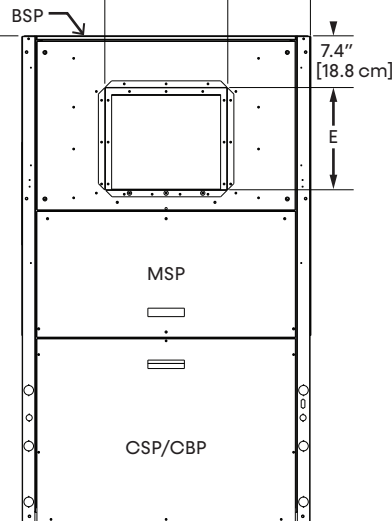
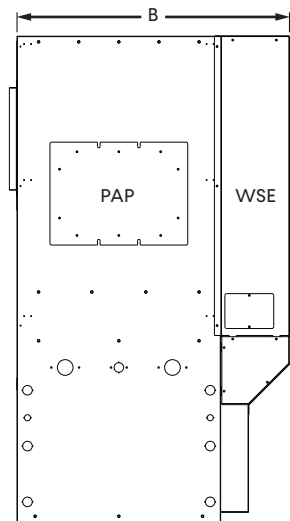
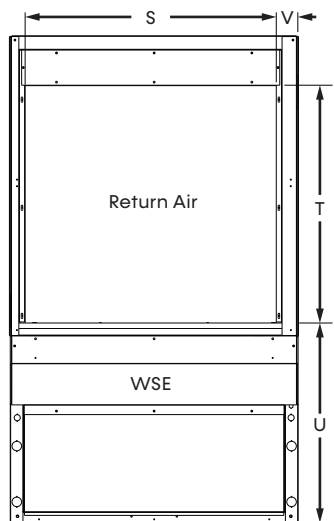
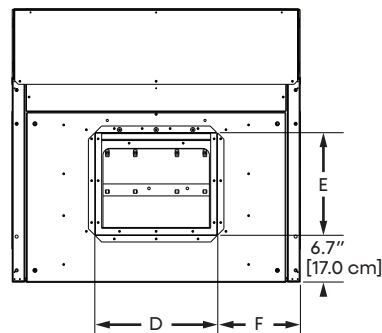

Back View  
Rear Return Front Discharge

Right Side View

Front View  
Rear Return Front Discharge

**NOTES**

- See the standard configuration for water connection and electrical knockout dimensions.
1. While clear access to all removable panels may not be required, installer should take care to comply with all building codes and allow adequate clearance for future field service.
  2. Units require 3 feet (91 cm) of clearance for water connections, WSE coil air bleed, CBP, CSP, BSP, PAP, and MSP.
  3. Condensate drain is internally trapped, externally vented.
  4. For top discharge units, BSP is on front. For front discharge units, BSP is on top. Allow 3 feet above unit for service.

**LEGEND**

- BSP = Blower Service Panel**
- CSP = Compressor Service Panel**
- CBP = Control Box Panel**
- MSP = Motor Service Panel**
- PAP = Pulley Access Panel**
- WSE = Waterside Economizer**

Models:  
MB  
072-300

# Dimensional Data MB168-240 Vertical

Unit Size	Overall Cabinet			Discharge Connections Duct Flange				Water Connections				Electrical Knockouts			Return Air Connections Using Return Air Opening						
	A	B	C	D	E	F	G	K	L	M	N	O	P	Q	S	T	U	V			
	Width	Depth	Height	Supply Width	Supply Height	Side Offset	Center Offset	1	2	3	Connection Height	1	2	3	Return Width	Return Height					
												1-3/8" (3.5cm)			7/8" (2.2 cm)						
168-240	inch	82.3	29.2	69.8	17.5	14.7	17.9	11.5	26.2	3.1	14.6	25.8	3.0	11.0	19.0	13.0	0.9	77.2	35.0	31.0	2.6
	cm	209.0	74.2	177.3	44.5	37.3	45.5	29.2	66.5	7.9	37.1	65.5	7.6	27.9	48.3	33.0	2.3	196.1	88.9	78.7	6.6

Front View Top Discharge

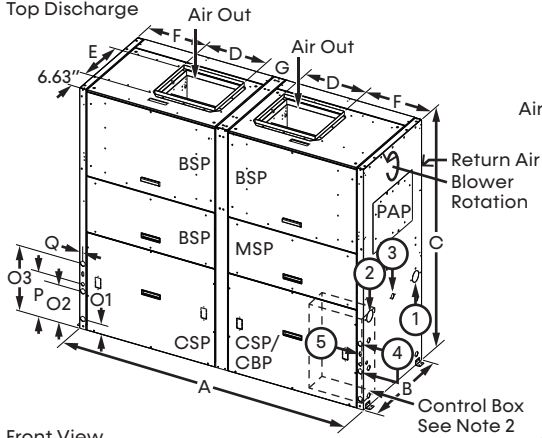

Front Return Rear Discharge (FR/RD)

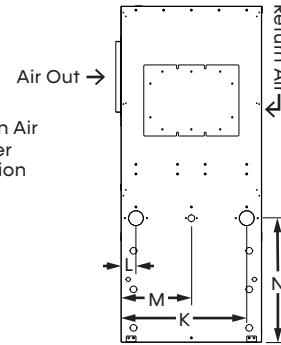

Rear View Top Discharge

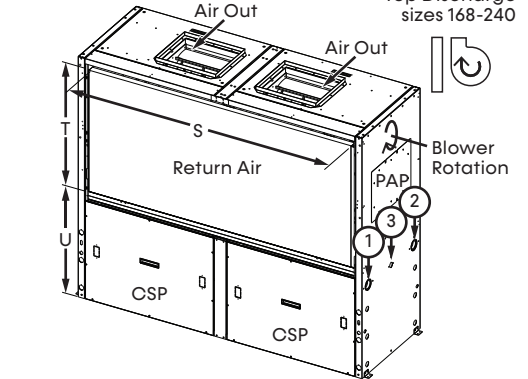

Front View Straight Discharge

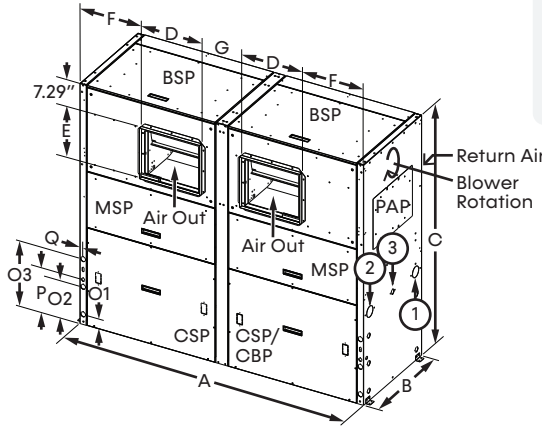

Rear View Straight Discharge

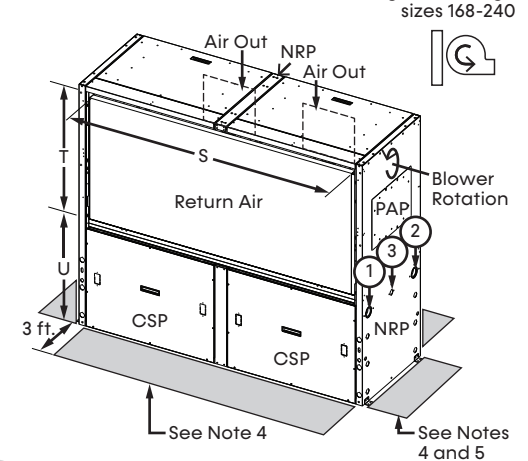

**LEGEND**

- BSP = Blower Service Panel
- CBP = Control Box Panel
- CSP = Compressor Service Panel
- MSP = Motor Service Panel
- PAP = Pulley Access Panel

**NOTES**

1. Condensate drain is available on either side (left or right) of unit. Drain hose and drain connection will be tied inside the unit. The installer will untie the drain hose, form trap, and connect to the condensate drain hole of installer's choice.
2. Electrical access is available on either side (left or right) of unit and is also available in the front on the left or right side of the unit.
3. Overall cabinet height and depth dimensions do not include duct flange or filter rails.
4. Units require 3 feet (91 cm) of clearance for water connections, CBP, CSP, MSP, and BSP service access. Service access is required at all removable panels locations and installer should take care to comply with all building codes and allow adequate clearance for future field service.
5. Filter removal is from right or left side of filter frame, allow 3 feet (91 cm) of access for servicing.

Legend	MB168-240
① Water Inlet	2" FPT
② Water Outlet	2" FPT
③ Condensate Drain <sup>1</sup>	1" FPT
④ High Voltage Access <sup>2</sup>	1-3/8" (3.49 cm)
⑤ Low Voltage Access <sup>2</sup>	7/8" (2.2 cm)

# Dimensional Data MB168-240 with WSE Vertical

Models:  
MB  
072-300

Unit Size		Overall Cabinet			Discharge Connections Duct Flange				Water Connections				Electrical Knockouts			Return Air Connections Using Return Air Opening					
		A	B	C	D	E	F	G	K	L	M	N	O	P	Q	S	T	U	V		
		Width	Depth	Height	Supply Width	Supply Height	Side Offset	Center Offset	1 Water In	2 Water Out	3 Condensate	Connection Height	1	2	3	Return Width	Return Height		Return Side Offset		
168-240	inch	82.3	42.0	69.8	17.5	14.7	17.9	11.5	26.1	3.1	14.6	25.8	3.0	11.0	19.0	15.1	0.9	76.0	34.0	30.7	3.6
	cm	209.0	106.7	177.3	44.5	37.3	45.5	29.3	66.3	7.9	37.1	65.5	7.6	27.9	48.3	38.4	2.3	193.0	86.4	78.0	9.1

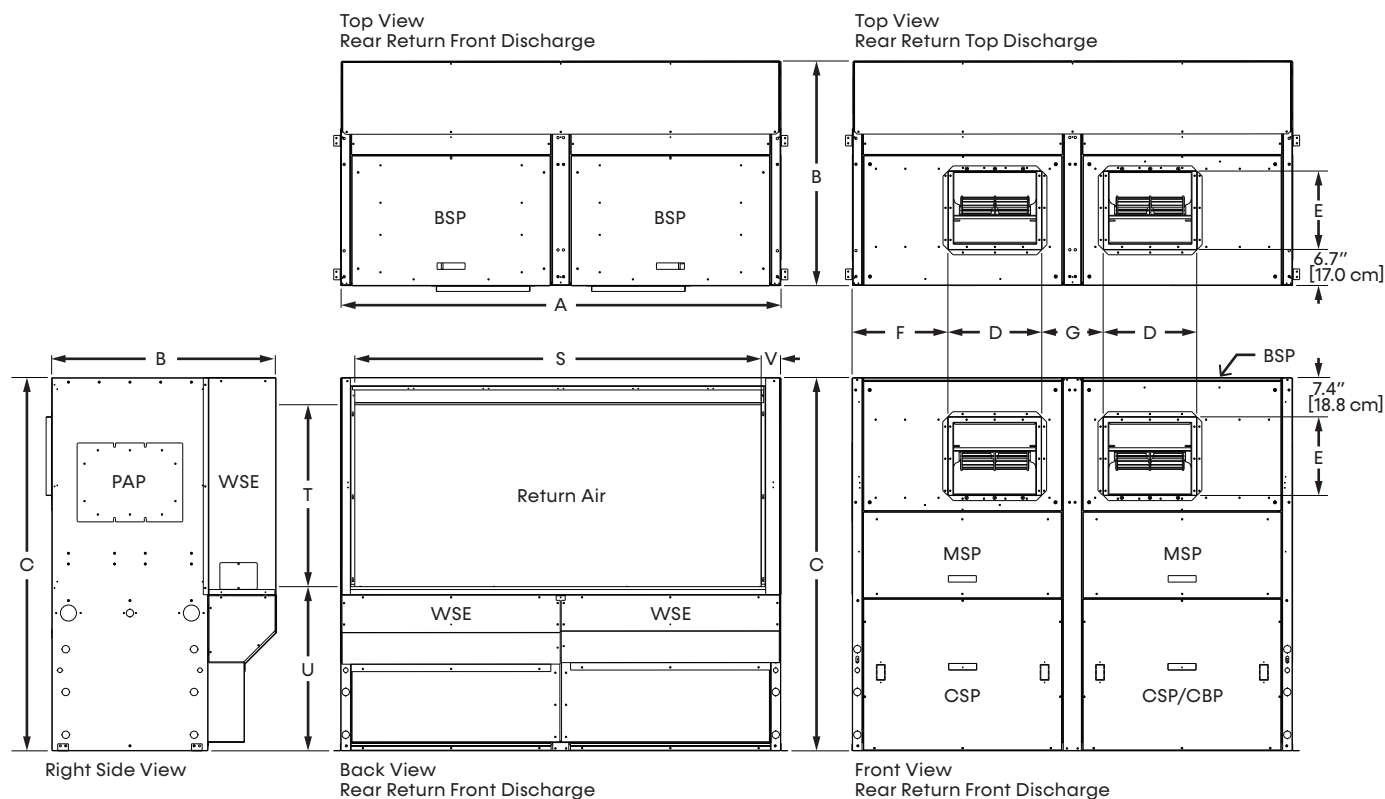

### NOTES

See the standard configuration for water connection and electrical knockout dimensions.

1. While clear access to all removable panels may not be required, the installer should take care to comply with all building codes and allow adequate clearance for future field service.
2. Units require 3 feet (91 cm) of clearance for water connections, WSE coil air bleed, CBP, CSP, BSP, PAP, and MSP.
3. Condensate drain is internally trapped, externally vented.
4. For top discharge units, BSP is on front. For front discharge units, BSP is on top. Allow 3 feet above unit for service.

### LEGEND

- BSP** = Blower Service Panel
- CSP** = Compressor Service Panel
- CBP** = Control Box Panel
- MSP** = Motor Service Panel
- PAP** = Pulley Access Panel
- WSE** = Waterside Economizer

Models:  
MB  
072-300

# Dimensional Data MB300 Vertical

Unit Size	Overall Cabinet			Discharge Connections Duct Flange				Water Connections				Electrical Knockouts			Return Air Connections Using Return Air Opening						
	A	B	C	D	E	F	G	K	L	M	N	O	P	Q	S	T	U	V			
	Width	Depth	Height	Supply Width	Supply Height	Side Offset	Center Offset	1	2	3	Connection Height	1	2	3	Return Width	Return Height					
								Water In	Water Out	Condensate		1-3/8" (3.5cm)			7/8" (2.2 cm)						
300	inch	82.3	29.2	69.8	17.5	14.7	6.3	8.6	25.8	3.4	14.6	24.2	3.0	11.0	19.0	13.0	0.9	77.2	35.0	31.0	2.6
	cm	209.0	74.2	177.3	44.5	37.3	16.0	21.8	65.5	8.6	37.1	61.5	7.6	27.7	48.3	33.0	2.3	196.1	88.9	78.7	6.6

Front View  
Top Discharge

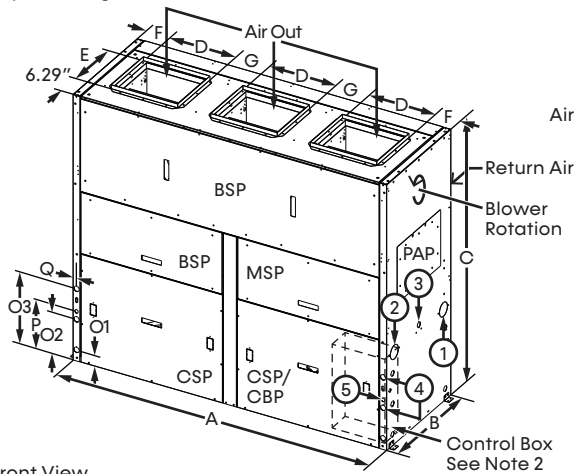

Right Side View  
Straight Discharge

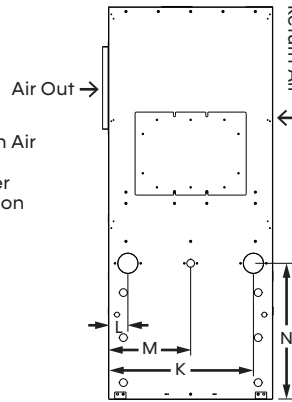

Rear Return  
Top Discharge

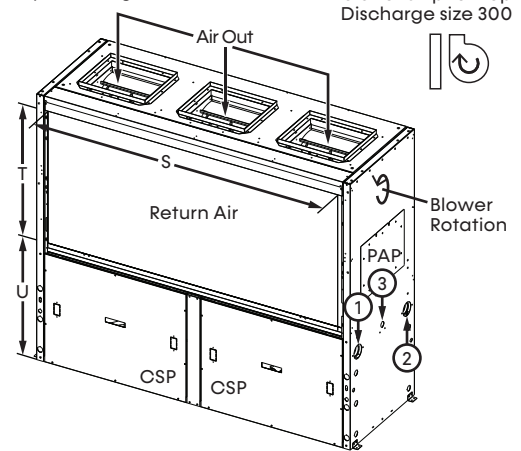

Blower to Air Coil  
relationship for Top  
Discharge size 300

Front View  
Straight Discharge

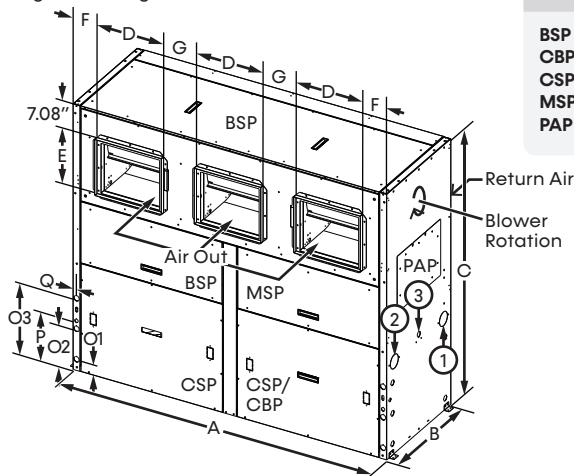

**LEGEND**

- BSP = Blower Service Panel
- CBP = Control Box Panel
- CSP = Compressor Service Panel
- MSP = Motor Service Panel
- PAP = Pulley Access Panel

Rear View  
Straight Discharge

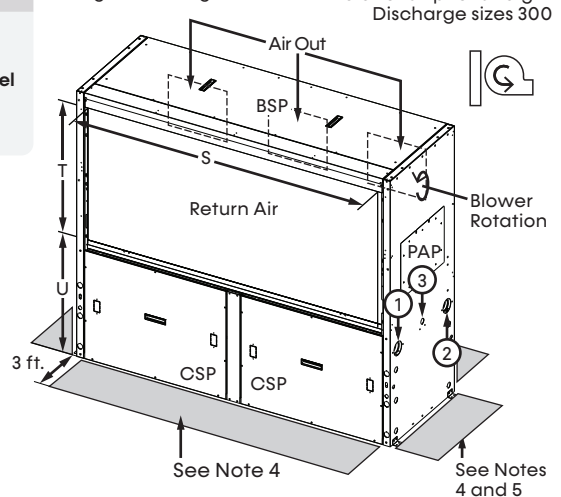

Blower to Air Coil  
relationship for Straight  
Discharge sizes 300

**NOTES**

- Condensate drain is available on either side (left or right) of unit. Drain hose and drain connection are tied inside the unit. The installer will untie the drain hose, form trap, and connect to the condensate drain hole of installer's choice.
- Electrical access is available on either side (left or right) of unit and is also available in the front on the left or right side of the unit.
- Overall cabinet height and depth dimension does not include duct flange for or filter rails.
- Units require 3 feet (91 cm) of clearance, CBP, CSP, MSP and BSP service access. While access to all removable panels may not be required, the installer should take care to comply with all building codes and allow adequate clearance for future field service.
- Filter removal is from right or left side of filter frame, allow 3 feet (91 cm) of access for servicing.

Legend	MB300
① Water Inlet	2-1/2" FPT
② Water Outlet	2-1/2" FPT
③ Condensate Drain <sup>1</sup>	1" FPT
④ High Voltage Access <sup>2</sup>	1-3/8" (3.49 cm)
⑤ Low Voltage Access <sup>2</sup>	7/8" (2.2 cm)

# Dimensional Data MB300 with WSE Vertical

Models:  
MB  
072-300

Unit Size	Overall Cabinet			Discharge Connections Duct Flange				Water Connections				Electrical Knockouts			Return Air Connections Using Return Air Opening						
	A	B	C	D	E	F	G	K	L	M	N	O	P	Q	S	T	U	V			
	Width	Depth	Height	Supply Width	Supply Height	Side Offset	Center Offset	1 Water In	2 Water Out	3 Condensate	Connection Height	1	2	3	Return Width	Return Height		Return Side Offset			
300	inch	82.3	42.0	69.8	17.5	14.7	6.4	8.6	25.8	3.4	14.6	24.2	3.0	11.0	19.0	15.1	0.9	76.0	34.0	30.7	3.6
	cm	209.0	106.7	177.3	44.5	37.3	16.3	21.8	65.5	8.6	37.1	61.5	7.6	27.9	48.3	38.4	2.3	193.0	86.4	78.0	9.1

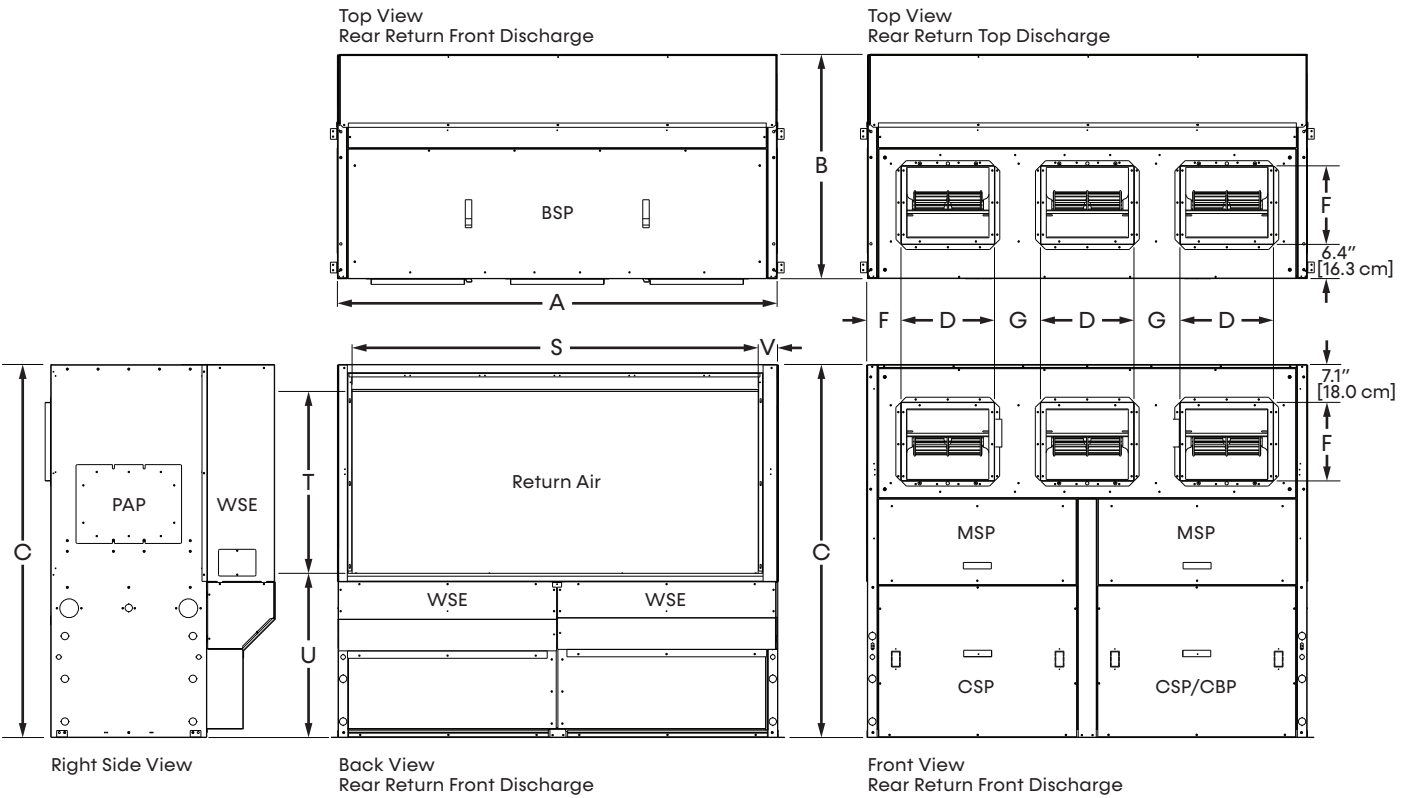

### NOTES

See the standard configuration for water connection and electrical knockout dimensions.

1. While clear access to all removable panels may not be required, installer should take care to comply with all building codes and allow adequate clearance for future field service.
2. Units require 3 feet (91 cm) of clearance for water connections, WSE coil air bleed, CBP, CSP, BSP, PAP, and MSP.
3. Condensate drain is internally trapped, externally vented.
4. For top discharge units, BSP is on front. For front discharge units, BSP is on top. Allow 3 feet above unit for service.

### LEGEND

- BSP** = Blower Service Panel
- CSP** = Compressor Service Panel
- CBP** = Control Box Panel
- MSP** = Motor Service Panel
- PAP** = Pulley Access Panel
- WSE** = Waterside Economizer

## Horizontal Installation

### HORIZONTAL UNIT LOCATION

Units are not designed for outdoor installation. Locate the unit in an INDOOR area that allows enough space for service personnel to perform typical maintenance or repairs without removing unit from the ceiling. Horizontal units are typically installed above a false ceiling or in a ceiling plenum. Never install units in areas subject to freezing or where humidity levels could cause cabinet condensation (such as unconditioned spaces subject to 100% outside air). Consideration should be given to access for easy removal of the filter and access panels. Provide sufficient room to make water, electrical, and duct connection(s). Allow 3-foot (91 cm) clearance for servicing unit through all access panels.

Make provisions for return air to freely enter the space by means of a louvered door or other means. If the unit is located in a confined space, such as a closet. Remove any access panel screws that may be difficult to remove after the unit is installed prior to setting the unit. Use the **Typical Horizontal Unit Installation** figure for an example of a typical installation. Refer to the unit submittal data or engineering design guide for dimensional data.

Conform to the following guidelines when selecting unit location:

- Provide a hinged access door in concealed spline or plaster ceilings. Provide removable ceiling tiles in T-bar or lay-in ceilings. Refer to horizontal unit dimensions for specific series and model in the unit's Product Catalog. Size the access opening to accommodate the service technician during the removal or replacement of the compressor, control, or blower assembly. Provide access to hanger brackets, water valves and fittings. Provide screwdriver clearance to access panels, discharge collars and all electrical connections.
- DO NOT obstruct the space beneath the unit with piping, electrical cables, and other items that prohibit future removal of components or the unit.
- Use a manual portable jack/lift to lift and support the weight of the unit during installation and servicing.

The installation of water-source heat pump units and all associated components, parts and accessories which make up the installation shall be in accordance with the regulations of ALL authorities having jurisdiction and MUST conform to all applicable codes. It is the responsibility of the installing contractor to determine and comply with ALL applicable codes and regulations.

**NOTE: Minimum clearances for installation are the same as the minimum required service clearances. Consult the service clearances or reference of installation clearances for more information.**

### MOUNTING HORIZONTAL UNITS

Horizontal units have four hanger brackets partially attached at the factory, one at each corner. Enclosed within the unit there is a hanger kit hardware bag containing vibration isolation grommets, washers, screws and a hanger installation instruction page. One additional screw from the hardware bag must be added to each hanger bracket before unit installation. Tighten each screw to 75 in-lbs (8.5 Nm). See the **Hanger Bracket** figure for reference. Refer to the hanger installation instruction page contained in the hardware bag for details of final hanger bracket attachment and unit suspension.

Use four (4) field-supplied threaded rods and factory-provided vibration isolators to suspend the unit. Safely lift the unit into position supporting the bottom of the unit. Ensure the top of the unit is not in contact with any external objects. Connect the top end of the four all-thread rods, slide rods through the brackets and grommet then assemble washers and double nuts at each rod. Ensure that the unit is approximately level and that the threaded rod extends past the nuts.

Pitch the unit toward the drain as shown in the **Horizontal Unit Pitch** figure to improve the condensate drainage.

# Horizontal Installation Service Access

Models:  
MB  
072-300

LEFT RETURN BACK DISCHARGE

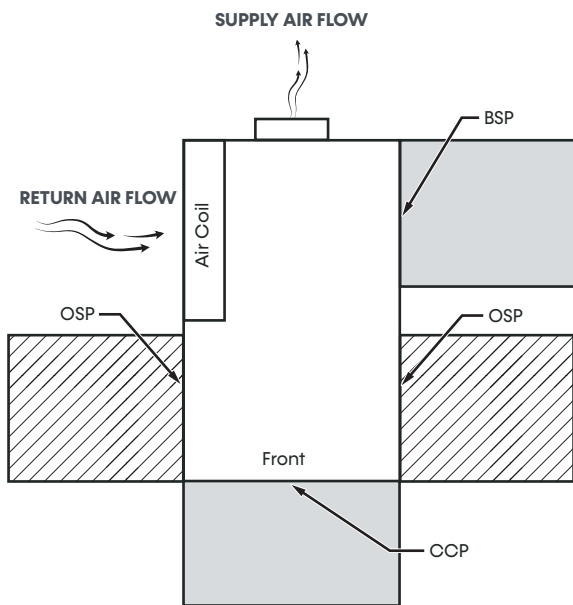

RIGHT RETURN BACK DISCHARGE

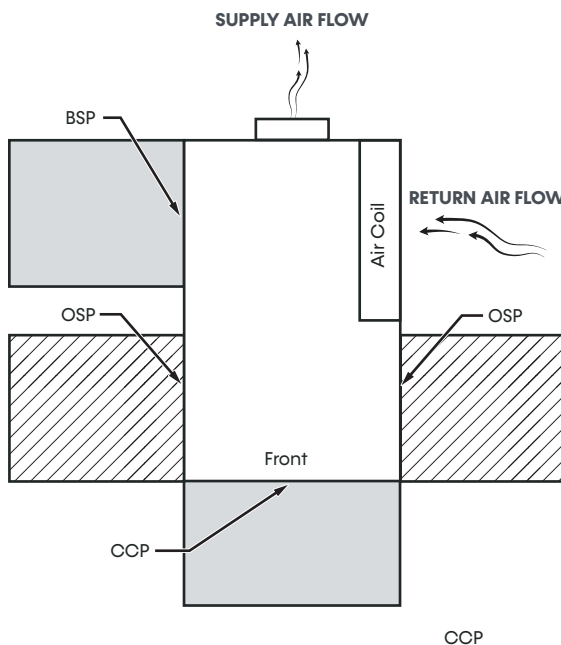

LEFT RETURN STRAIGHT DISCHARGE

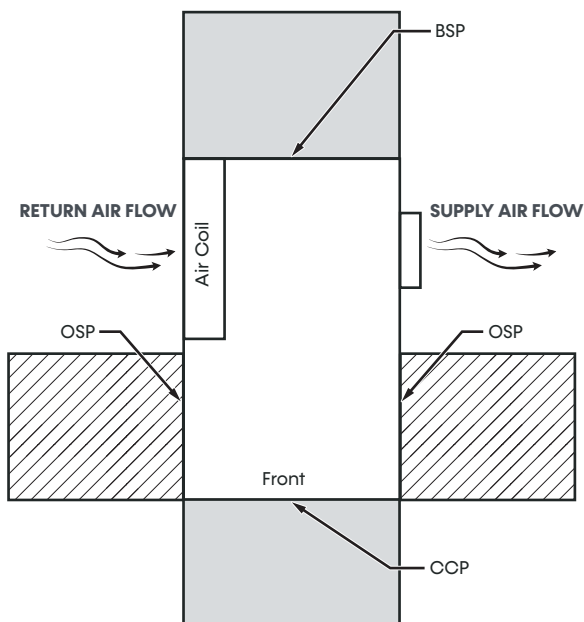

RIGHT RETURN STRAIGHT DISCHARGE

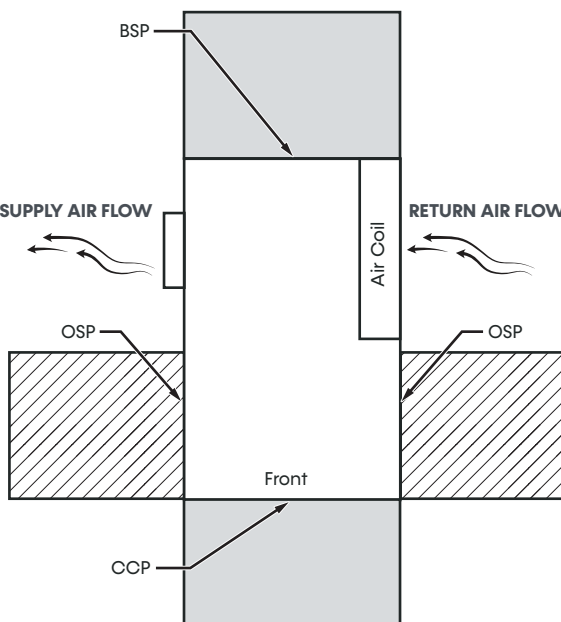

**NOTES**

1. While clear access to all removable panels is not required, installer should take care to comply with all building codes and allow adequate clearance for future field service.
2. COP and BSP requires 2-feet of service access.
3. Blower service access is through back panel on straight discharge units or through panel opposite air coil on back discharge units.
4. OSP are removable panels that provide additional access to the units interior. Clear access to OSP panels is not required and they are not to be used in place of the mandatory CCP and BSP panels.

- = Mandatory Service Access 2-foot (61 cm)
- = Optional Service Access 2-foot (61 cm)

**LEGEND**

- COP = CONTROL/COMPRESSOR ACCESS**
- BSP = BLOWER SERVICE PANEL**
- OSP = OPTIONAL SERVICE PANEL (NOT REQUIRED)**

Models:  
MB  
072-300

## Horizontal Installation

**Figure 1: Hanger Bracket**

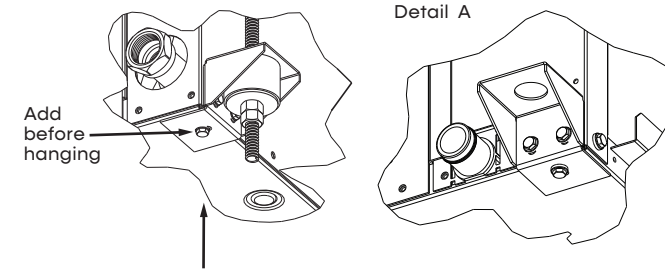

View: Water connection end fully assembled  
(Unit pictured for hanger bracket reference)  
(Water hardware may vary per unit model)

**Figure 2: Horizontal Unit Pitch**

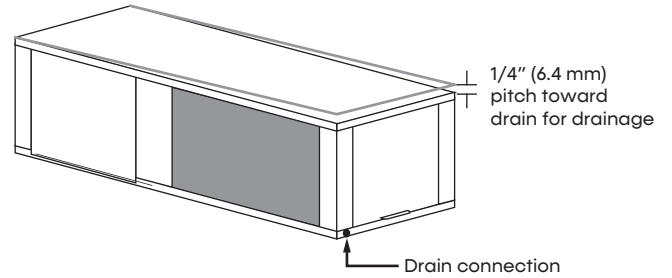

**Figure 3: Typical Horizontal Unit Installation**

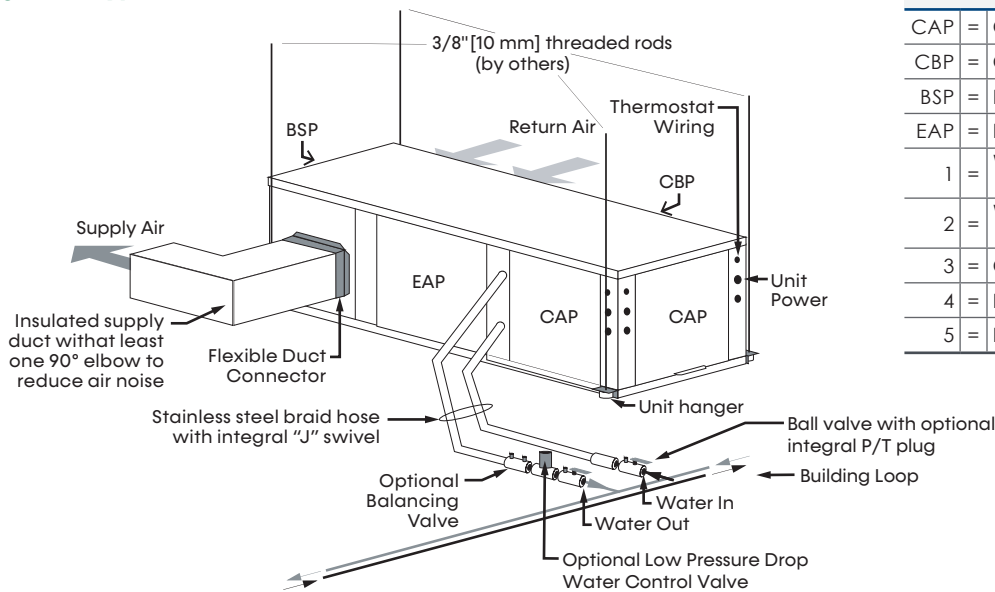

**Legend inch (cm)**

CAP	=	Compressor Access Panel
CBP	=	Control Box Panel
BSP	=	Blower Service Panel
EAP	=	Expansion Valve Access Panel
1	=	Water Outlet - 1-1/4 (3.2) FPT (072-096) 1-1/2 (3.8) FPT (120)
2	=	Water Inlet - 1-1/4 (3.2) FPT (072-096) 1-1/2 (3.8) FPT (120)
3	=	Condensate 3/4 (1.9) FPT
4	=	High Voltage 1-1/8 (2.9) KO
5	=	Low Voltage 7/8 (2.2) KO

**NOTES**

1. Service access is required for all removable panels and installer should take care to comply with all building codes and allow adequate clearance for future field service.
2. Water inlet and water outlet connections are available on either side (left or right) of the unit.
3. Condensate drain is 3/4-inch FPT and is located on cabinet end opposite the compressor.
4. Electrical access is available on either side (left or right) of the front.
5. Electric box is on right side. It can be field converted to left side. Conversion should only be attempted by qualified service technician. If electric box relocated to opposite side, and water connected to opposite side, then this access is not required.
6. Units require 3 feet (90.1 cm) of clearance for water connections, CAP, CBP, EAP, and BSP service access.
7. Overall cabinet width dimensions does not include filter rail and duct flange.
8. Units are shipped with air-filter rails that are not suitable for supporting return air ductwork. An air-filter frame with duct-mounting collar is available as an accessory.

### AIR COIL

To obtain maximum performance, the air coil should be cleaned before startup. A 10% solution of dishwasher detergent and water is recommended for both sides of the coil. A thorough water rinse should follow. **Do not use ultraviolet-based antibacterial systems.**

**NOTICE**

Installation Note - Ducted Return: Many horizontal WSHPs are installed in a return air ceiling plenum application (above ceiling). Vertical WSHPs are commonly installed in a mechanical room with free return (e.g. louvered door). Filter rails are the industry standard and are included on commercial heat pumps only for holding the filter. For ducted return applications, the filter rail must be removed and replaced with a duct flange or filter frame. Canvas or flexible connectors should also be used to minimize vibration between the unit and ductwork.

## Horizontal Installation

### CONDENSATE PIPING

A condensate drain line must be installed and pitched away from the unit to allow for proper drainage. This connection must meet all local plumbing/building codes.

Pitch the unit toward the drain as shown in the **Horizontal Condensate Connection** figure to improve the condensate drainage.

Install condensate trap at each unit with the top of the trap positioned below the unit condensate drain connection as shown in Horizontal Unit Pitch. Design the depth of the trap (water-seal) based upon the amount of ESP capability of the blower (where 2 inches [51 mm] of ESP capability requires 2 inches [51 mm] of trap depth). As a general rule, 1½-inch [38 mm] trap depth is the minimum.

Each unit must be installed with its own individual trap and connection to the condensate line (main) or riser. Provide a means to flush or blow out the condensate line. **DO NOT** install multiple units with a common trap and/or vent.

Always vent the condensate line when dirt or air can collect in the line or a long horizontal drain line is required. Also vent when large units are working against higher external static pressure than other units connected to the same condensate main since this may cause poor drainage for all units on the line. **WHEN A VENT IS INSTALLED IN THE DRAIN LINE, IT MUST BE LOCATED AFTER THE TRAP IN THE DIRECTION OF THE CONDENSATE FLOW.**

### STANDARD & STAINLESS STEEL DRAIN PANS

The condensate connection is female pipe thread. Field-provided male adapter required for condensate drain connection.

**Figure 4: Horizontal Condensate Connection**

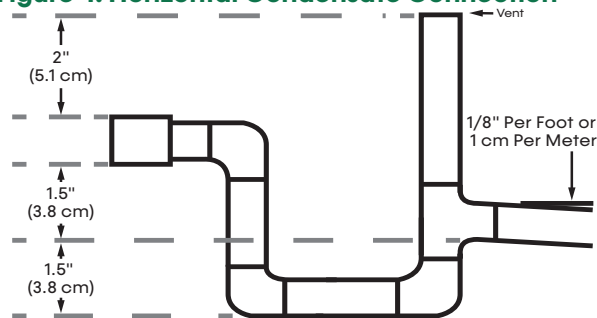

#### CAUTION

Ensure condensate line is pitched toward drain 1/8 inch per foot [11 mm per m] of run.

**Figure 5: Right Return Side Discharge to Back**

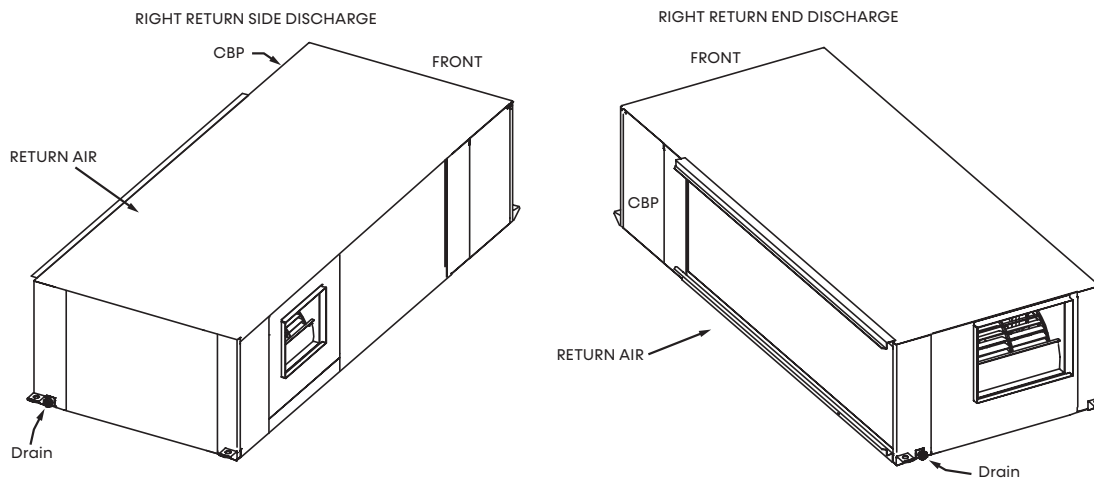

Models:  
MB  
072-300

## Horizontal Installation

### DUCT SYSTEM INSTALLATION

Proper duct sizing and design is critical to the performance of the unit. The duct system should be designed to allow adequate and even airflow through the unit during operation. Air flow through the unit **MUST** be at or above the minimum rated airflow for a given unit size to avoid equipment damage. Duct systems should be designed for quiet operation. Refer to the following horizontal and vertical duct system example figures:

- **Typical Horizontal Unit Installation**
- **Typical Vertical Unit Installation**

A flexible connector is recommended for both discharge and return air duct connections on metal duct systems to eliminate the transfer of vibration to the duct system. To maximize sound attenuation of the unit blower, the supply and return plenums should include internal fiberglass duct liner or be constructed from ductboard for the first few feet. Application of the unit to uninsulated ductwork in an unconditioned space is not recommended, as the unit's performance may be adversely affected.

Include at least one 90-degree elbow in the supply duct to reduce air noise. If air noise or excessive air flow is a problem, adjust the blower speed. For airflow charts, consult submittal data for the series and model of the specific unit.

If the unit is connected to existing ductwork, a previous check should have been made to ensure that the ductwork has the capacity to handle the airflow required for the unit. If ducting is too small, as in the replacement of a heating only system, a larger ductwork should be installed. All existing ductwork should be checked for leaks and repaired as necessary.

An unventilated area where water-source heat pump is installed and surpasses a R-454B refrigerant charge of 62 oz (1.76 kg), shall be without continuously operating open flames (for example an operating gas appliance) or other **POTENTIAL IGNITION SOURCES** (for example an operating electric heater, hot surfaces).

Only auxiliary electric heaters approved by the manufacturer shall be installed in connecting ductwork. The installation of any other auxiliary devices is beyond the manufacturer's responsibility.

For duct-connected units, false ceilings or drop ceilings may be used as a return air plenum as long as the the manufacturer RDS is installed as shown in the **RDS Installation** figure in the *Electrical Refrigerant Detection System* section.

#### **WARNING**

Ducts connected to an appliance shall not contain a **POTENTIAL IGNITION SOURCE**.

#### **WARNING**

Keep any required ventilation openings clear of obstruction.

#### **WARNING**

For mechanical ventilation, the lower edge of the air extraction opening where air is exhausted from the room shall not be more than 3.94 inches (100 mm) above the floor. The location where the mechanical ventilation air extracted from the space is discharged shall be separated by a sufficient distance, but not less than 9.84 feet (3 m), from mechanical ventilation air intake openings, to prevent recirculation to the space.

# Horizontal Installation Field Conversion of Air Discharge

Models:  
MB  
072-300

## WARNING

To prevent injury or death from electrical shock, disconnect electrical power source.

## OVERVIEW

Horizontal units can be field converted between straight (side) and back (end) discharge using the instructions below.

**NOTE: It is not possible to field convert return air between left or right return models due to the necessity of refrigeration copper piping changes.**

## PREPARATION

Field conversion must be completed on the ground. If the unit is already hung, it should be taken down for the field conversion. Place in a well-lighted area. Conversion should only be attempted by a qualified service technician.

## SIDE-TO-BACK DISCHARGE CONVERSION

1. Remove back panel and side access panel
2. Loosen two motor-slide nuts, raise motor-slide assembly and remove belt and motor sheave.
3. Remove blower sheave. Remove motor bolts and carefully remove motor.
4. Remove two motor clips and reattach to opposite side.
5. Unbolt (three per side) complete housing assembly.
6. Rotate complete assembly into new position. Locate over mounting holes in base, reattach using three bolts per side.
7. Mount motor, motor sheave, blower sheave and belt. Make sure wires are not pinched and not over sharp edges. Adjust motor downward to tighten belt. Raise or lower motor slide assembly with adjusting bolt and retighten two slide nuts. Check for correct tension (See Tensioning V-Belt Drives page). Rewire motor (at contactor) for correct rotation. Spin blower wheel to ensure wheel is not obstructed.
8. Replace two panels.

## BACK-TO-SIDE DISCHARGE CONVERSION

If the discharge is changed from back to side, use Side-to-Back conversion steps noting that illustrations are reversed.

## LEFT VERSUS RIGHT RETURN

It is not possible to field convert return air between left or right return models due to the necessity of refrigeration copper piping changes. However, the conversion process of side to back or back to side discharge for either right or left return configuration is the same. In some cases, it may be possible to rotate the entire unit 180 degrees if the return air connection needs to be on the opposite side. Rotating the unit moves the piping to the other end of the unit.

### Step 1: Remove Blower Panel and Access Panel

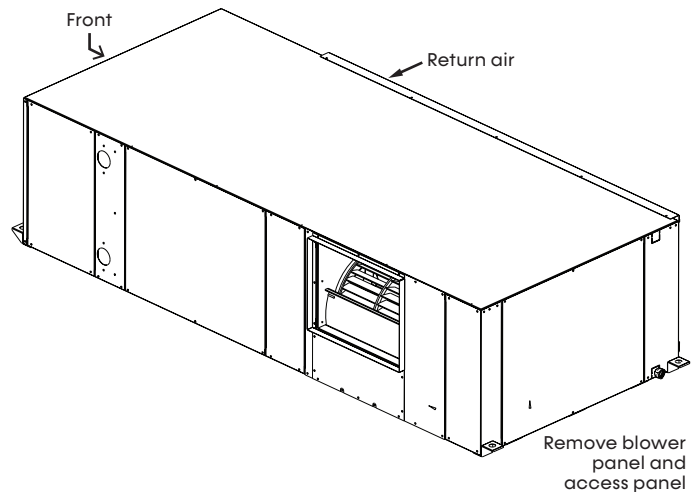

### Step 2: Access Blower Housing Assembly

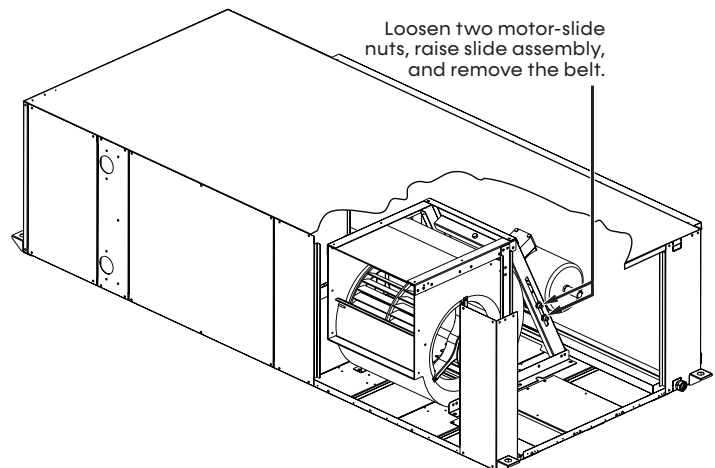

Models:  
MB  
072-300

# Horizontal Installation Field Conversion of Air Discharge

## Step 3: Prepare Blower Housing Assembly

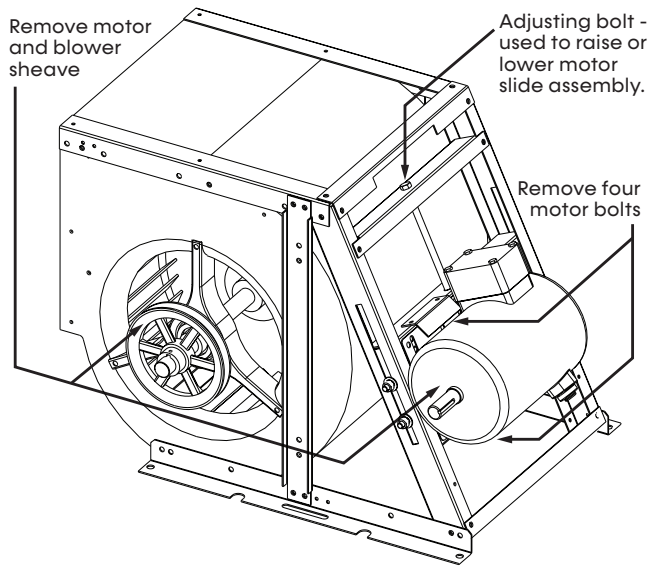

## Step 5: Remove Bolts

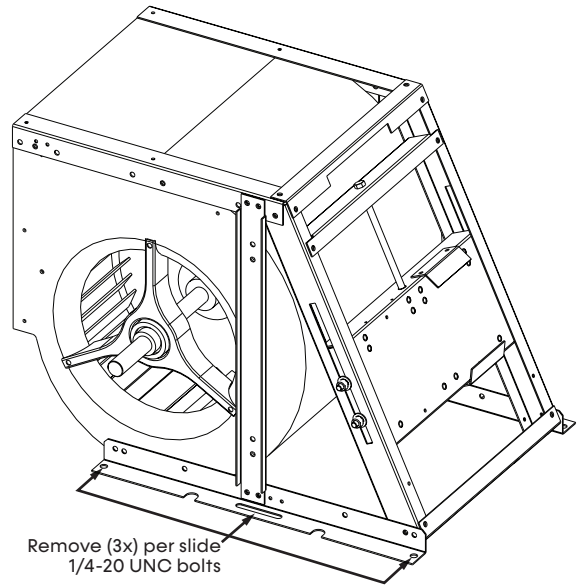

## Step 4: Change Motor Clip Orientation

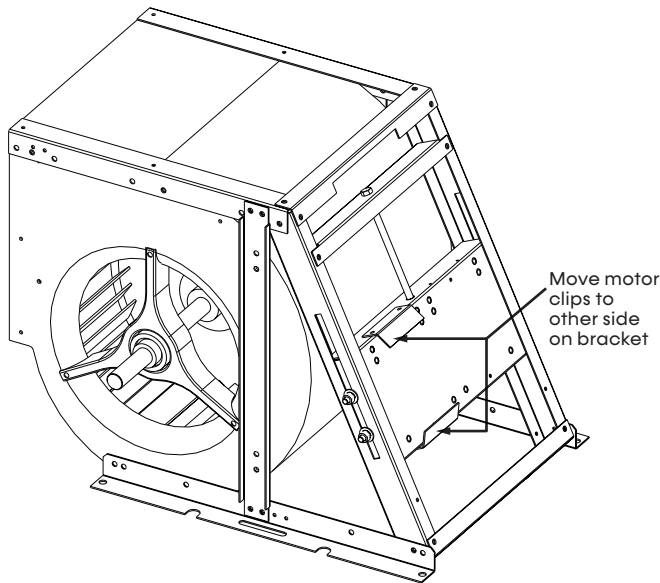

## Step 6: Rotate Blower Housing and Bolt Down

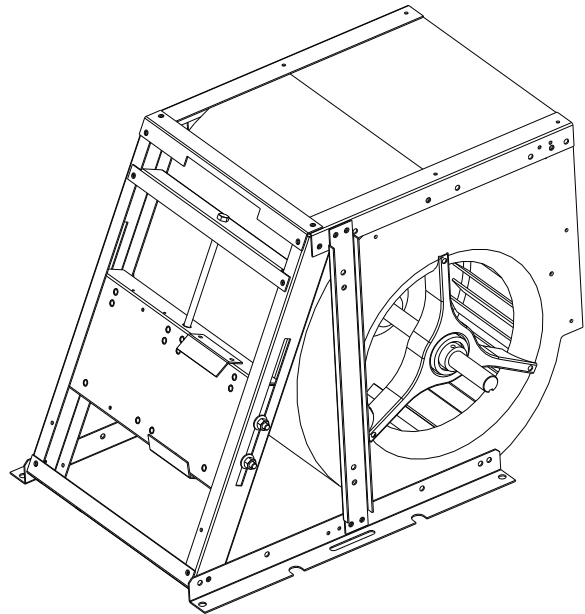

Rotate entire blower housing assembly to rest at back end of the unit. Locate housing holes and bolt down using previous 1/4-20 UNC bolts (3x) each side.

# Horizontal Installation Field Conversion of Air Discharge

Models:  
MB  
072-300

**Step 7: Secure Motor, Motor Sheave,  
Blower Sheave, and Belt**

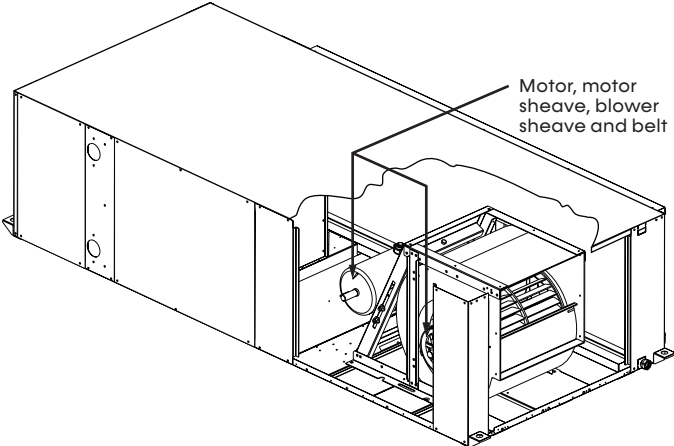

**Step 8: Secure Blower Panel and Access Panel**

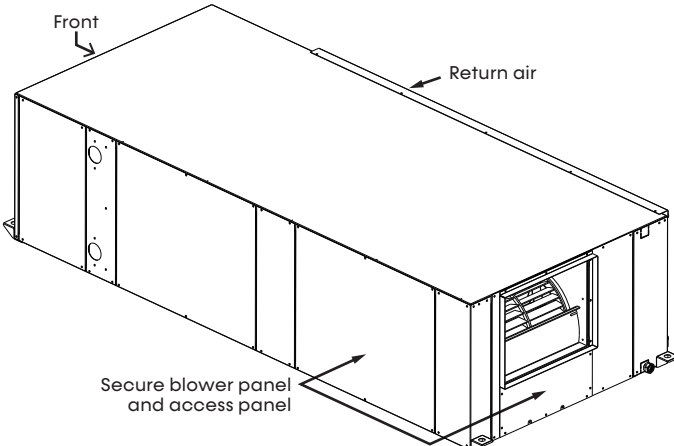

Models:  
MB  
072-300

## Vertical Installation

### VERTICAL LOCATION AND ACCESS

MB units are not designed for outdoor installation. Locate the unit in an INDOOR area that allows enough space for installation and for service personnel to perform typical maintenance or repairs. MB units are typically installed in a floor level closet or in a small mechanical room. Refer to the **Typical Vertical Unit Installation** figure for an example of a typical installation. Install units with adequate clearance to allow maintenance and servicing. **NOTE: Minimum clearances for installation are the same as the minimum required service clearances. Consult the service clearances on for reference of installation clearances.** Conform to the following guidelines when selecting unit location:

- Provide adequate clearance for filter replacement and drain pan cleaning. DO NOT block filter access with piping, conduit, or other materials. Refer to the product catalog for unit dimensions.
- Provide access for fan and fan motor maintenance and for servicing of the compressor and coils without removal of the unit.
- Provide an unobstructed path to the unit within the closet or mechanical room to enable removal of the unit if necessary.
- Provide access to water valves and fittings, and screwdriver access to the unit side panels, discharge collar and all electrical connections

### DUCT SYSTEM DESIGN AND INSTALLATION GUIDELINES

The following application guidelines must be used when installing the MB. Failure to follow these guidelines could result in unsatisfactory unit performance and/or premature failure of some unit components. The manufacturer will not warranty, or accept responsibility for products which fail, have defects, damage or insufficient performance as a result of improper application.

- The duct system must be sized to handle the airflow quietly and must not exceed the maximum allowable External Static Pressure. To maximize sound attenuation, metal supply and return ducts should include internal insulation or be of duct-board construction for the first 10 feet or end of first full-sized elbow.
- Install a flexible connector in all supply and return air ducts close to the unit to inhibit sound transfer to the ducts.
- Do not install uninsulated ducts in an unconditioned space. The unit performance will be adversely affected and damage from condensate can occur.

**Figure 6: Typical Vertical Unit Installation**

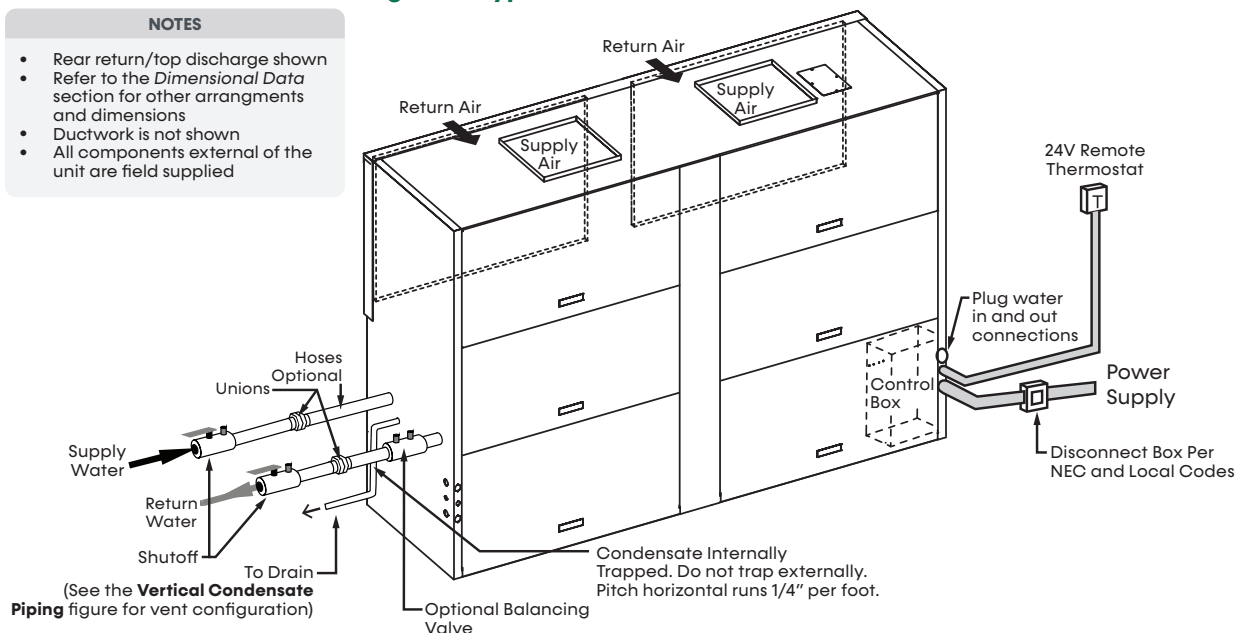

**NOTES**

- Rear return/top discharge shown
- Refer to the *Dimensional Data* section for other arrangements and dimensions
- Ductwork is not shown
- All components external of the unit are field supplied

# Vertical Installation Service Access

Models:  
MB  
072-300

VERTICAL UNITS

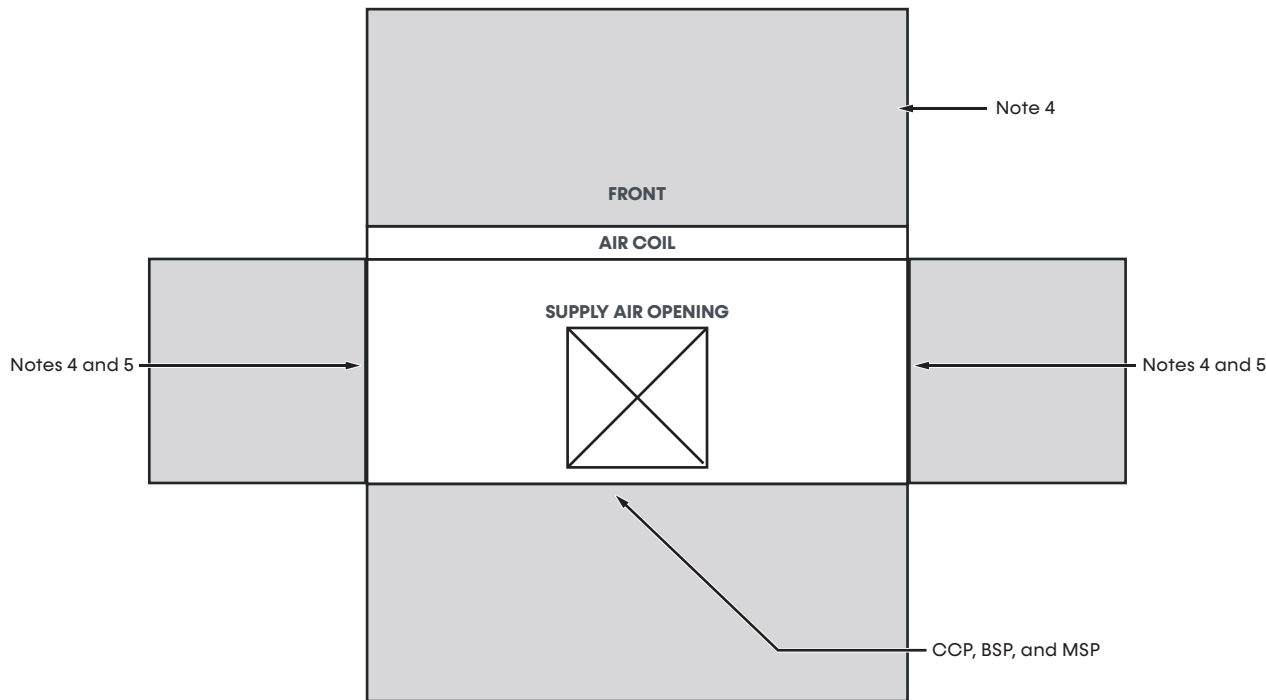

NOTES

1. Condensate drain is available on either side (left or right) of unit. Drain hose and drain connection will be tied inside the unit. The installer will untie the drain hose, form trap, and connect to the condensate drain hole of installer's choice.
2. Electrical access is available on either side (left or right) of unit and is also available in the front on the left or right side of the unit.
3. Overall cabinet height and depth dimension does not includeduct fange for or filter rails.
4. Units require 3 feet (91 cm) of clearance, CBP, CSP, MSP and BSP service access. While access to all removable panels may not be required, the installer should take care to comply with all building codes and allow adequate clearance for future field service.
5. Filter removal is from right or left side of filter frame. Allow 3 feet (91 cm) of access for servicing.

LEGEND

**CCP = CONTROL/COMPRESSOR ACCESS**  
**BSP = BLOWER SERVICE PANEL**  
**MSP = MOTOR SERVICE PANEL**

 = Mandatory Service Access 3 feet (91.4 cm)

Models:  
MB  
072-300

# Vertical Installation Field Conversion of Air Discharge (072-120)

**WARNING**

To prevent injury or death from electrical shock, disconnect electrical power source.

## OVERVIEW

Vertical unit sizes 072-120 can be field converted between top and straight (side) discharge and back (end) discharge using the instructions below.

**NOTE: Field conversion of discharge air is not available in vertical unit sizes 168 to 300. Be sure to order your unit with the proper discharge air configuration.**

## PREPARATION

Place in a well-lit area. Conversion should only be attempted by qualified service technicians.

**NOTE: To convert from straight discharge to top discharge, reverse the following steps.**

### Step 1: Remove Panels

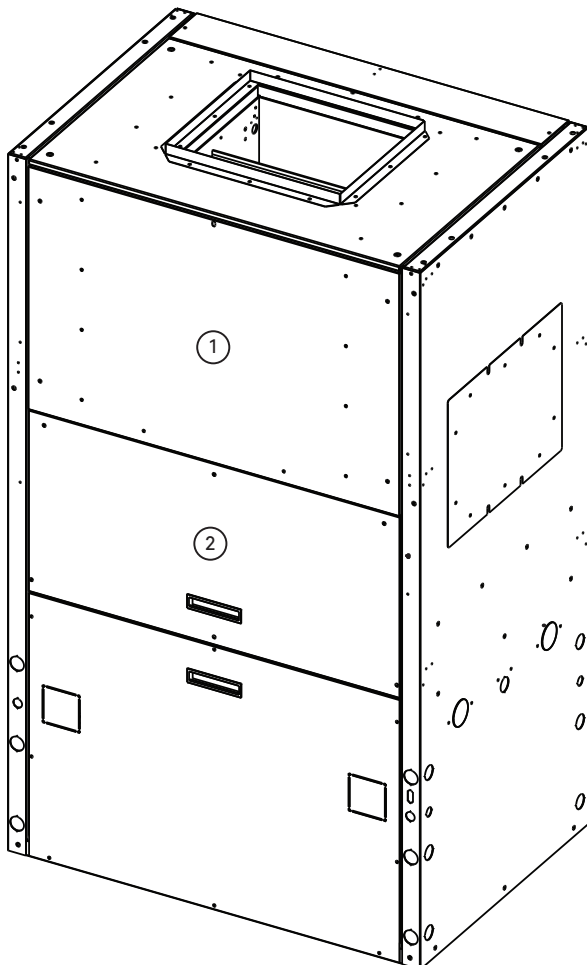

### Step 2: Remove Screws

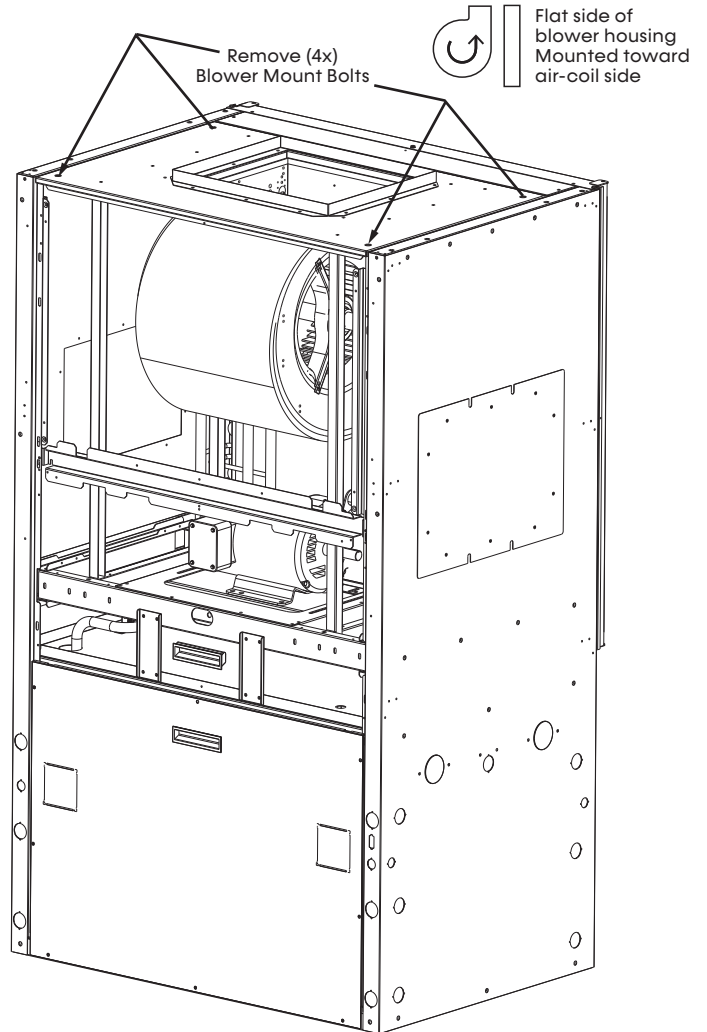

# Vertical Installation Field Conversion of Air Discharge (072-120)

Models:  
MB  
072-300

### Step 3: Rotate and reattach blower

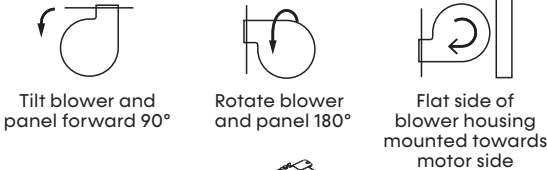

Replace (4x) Blower Mount Bolts

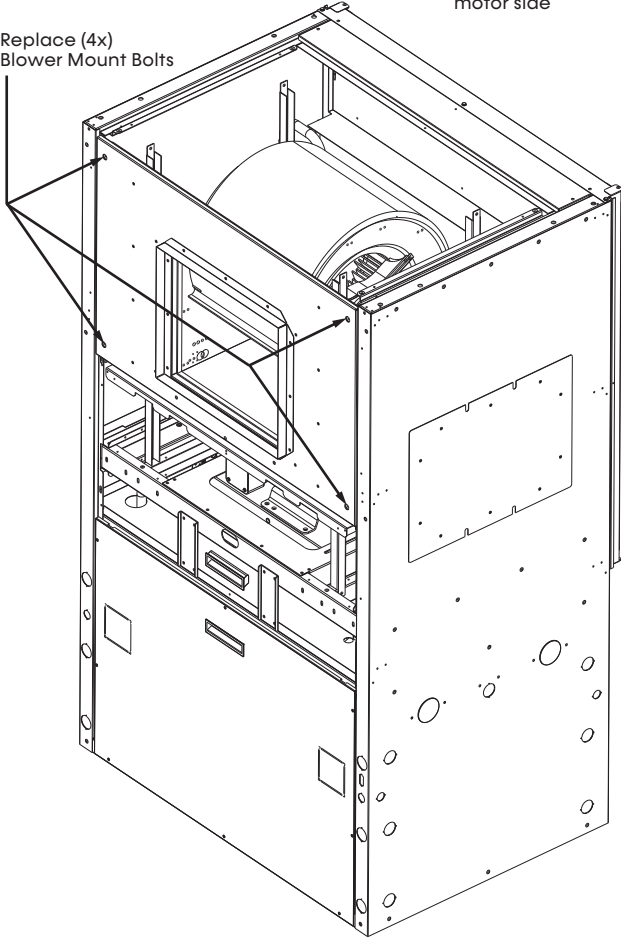

### Step 4: Replace and Secure Panels

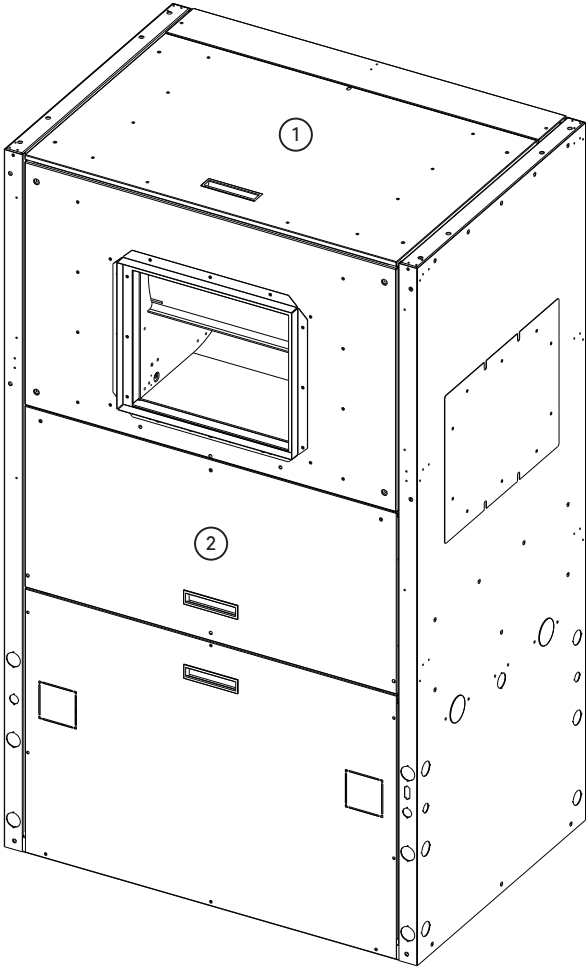

Models:  
MB  
072-300

# Vertical Installation Field Conversion of Control Box (072-300)

## ⚠ WARNING

To prevent injury or death from electrical shock, disconnect electrical power source.

## ⚠ NOTICE

You must provide three feet service access (or meet code requirements) for the new control box location.

## OVERVIEW

The vertical unit control box can be field converted from front to any other corner for unit sizes 168-300, or opposite corner (water coil side) for unit sizes 072-120.

## PREPARATION

Place in a well-lit area. Conversion should only be attempted by a qualified service technician.

### Step 1: Remove Panels (MB168-300)

Remove panels 1-6 and dividers necessary to reroute wires to new control box location.

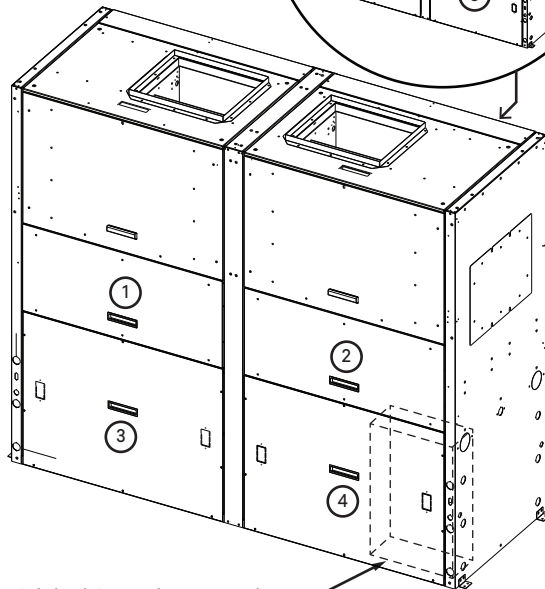
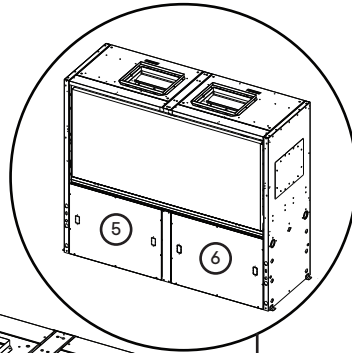

Original Control Box Location for Back Return Top Discharge

Note: SB168-240 chassis shown.

### Step 2: Remove Panels (MB072-120)

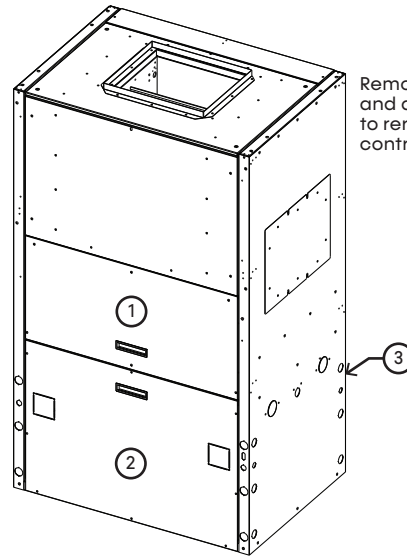

**NOTE: After completing step 1, follow steps 2-7 for all sizes.**

1. Tag and detach all wires from components, pull wires out of control box, then remove the control box.
2. Attach box to new location.
3. Reroute wires.

**NOTE: Keep wires away from hot lines and sharp edges.**

4. Reattach wires.

**NOTE: Reattach Circuit 1 to the same compressor so that the compressor configuration does not change. Only the location of the control box should change.**

5. Verify wiring in the unit matches the configuration wiring diagram.
6. Replace panels.

# Vertical Installation

## Field Conversion of Water Connections (072-240)

Models:  
MB  
072-300

### ⚠ WARNING

To prevent injury or death from electrical shock, disconnect electrical power source.

### OVERVIEW

For vertical unit sizes 072-240, the water connection can be field converted to opposite side. Connections can be both left, right, or one on each side.

**NOTE: Field Conversion of Water Connections is not available on unit size 300. Be sure to order the proper water-connection hand configuration.**

### PREPARATION

Field conversion must be completed on the ground. If the unit is already hung it should be taken down for the field conversion. Place in a well-lit area. Conversion should only be attempted by a qualified service technician.

#### Left or Right Side-to-Back Discharge Conversion

**NOTE: Water connection direction is determined when facing the motor side of the unit:**

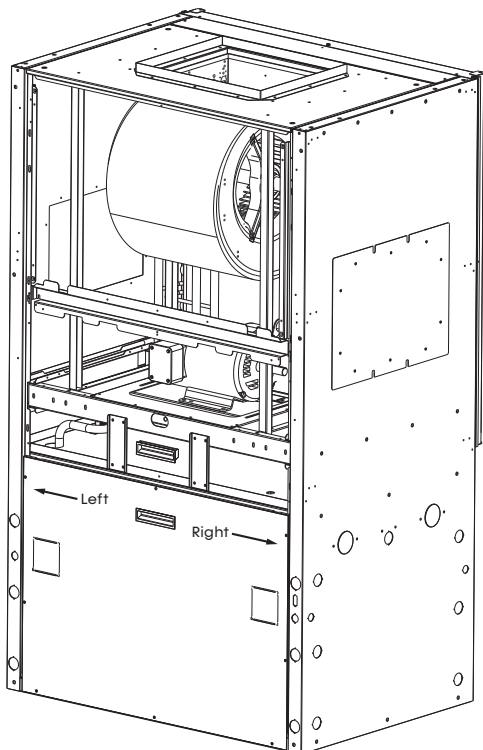

1. Remove panels needed for access to water connections.
2. Remove screws from side panels. Loosen (4x) screws in slots but do not remove.
3. Both water in and out have a union centered in the middle of the unit. Undo both unions, rotate the water legs for opposite configuration, retighten unions, then reattach connection flanges to wrappers. Use slots to adjust and retighten screws in slots.
4. Replace panels.
5. Ensure wiring is per wire diagram.

Models:  
MB  
072-300

# Vertical Installation Condensate Installation

## CONDENSATE PIPING

Remove KO on the side to which that drain will be connected. Remove access panels. Inside the unit, untie and uncoil drain hose. Form a trap in the hose ensuring the hose is not kinked or deformed. Connect plate assembly to the side frame with two screws.

Outside of unit, connect 1-inch MPT fitting to the plate assembly. Run the line to building drain. Horizontal runs must be pitched ¼ inch per foot (10 mm per 46 cm) toward drain. Do not trap externally.

The **Vertical Condensate Piping** figure illustrates a typical trap and vent used with the MB.

**Figure 7: Vertical Condensate Piping**  
All fittings and tubing outside of the unit are field supplied.

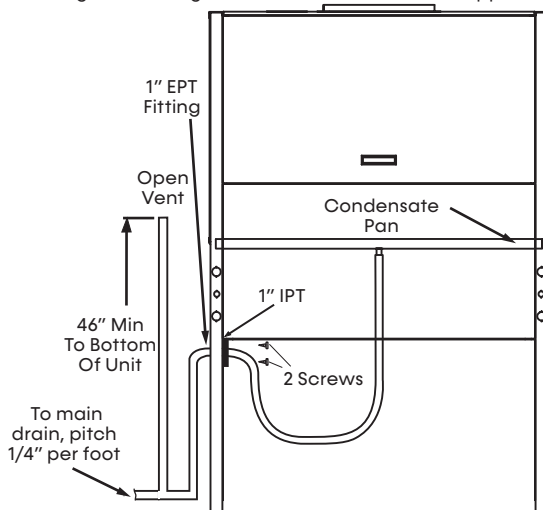

Each unit must be installed with its own individual line to the building's main condensate drain line or riser. Provide a means to flush or blow out the condensate line. **DO NOT** install units with a common trap and or vent. Always vent the condensate line when dirt or air can collect in the line or a long horizontal drain line is required. Also vent when large units are working against higher external-static pressure than other units connected to the same condensate main since this may cause poor drainage for all units on the line. **WHEN A VENT IS INSTALLED IN THE DRAIN LINE, IT MUST BE LOCATED AFTER THE TRAP IN THE DIRECTION OF THE CONDENSATE FLOW** and opening 46 inches (117 cm) minimum from bottom of unit. Vent the condensate piping per code.

### ⚠ WARNING

Ensure condensate line is pitched toward drain ¼ inch per foot [10mm per 46cm] of run.

Horizontal and Vertical Installations – Drain main or riser must be sized for all units connected to it.

Pipe Size inch (mm)	Connected Tons	Connected kW
3/4 (19)	<4	<14
1 (25)	<6	<21
1-1/4 (32)	<30	<105
1-1/2 (38)	<50	<175
2 (51)	<150	<527
3 (76)	<300	<1055
4 (102)	<500	<1758

Ensure all connections are secure and water tight.

After drain is connected to main and all drain connections are secure and water tight, pour one gallon of water into condensate pan. The water should drain out freely. Repair any leaks.

- On units with multiple fan outlets a “pair of pants” duct connection must be used for proper air balance and distribution and to prevent fan oscillation.
- Include at least one 90-degree turn in supply air ducts to reduce noise transmission.
- Existing ducts must be checked to ensure proper size and configuration prior to installation of any replacement unit. Also inspect for and repair all air leaks in existing ducts.
- Units may only be connected to a dedicated duct system. Consult the factory BEFORE connecting multiple units to a common duct system.
- Never connect a unit to a duct system with automatic or modulating dampers, VAV boxes, etc. in the supply air system. Never allow a situation where the total unit CFM can drop below the minimum required for proper unit operation.
- Never connect a bypass damper from the supply air duct to the return air duct. Never allow the return air temperature to drop below the minimum allowable normal temperature for proper unit operation.
- Do not use MB units for 100% outdoor air treatment. Do not add hot-gas-bypass to “convert” a unit for outdoor air treatment. Always use a dedicated outdoor air unit for outdoor air treatment.
- Do not exceed 10% of the total unit CFM with untreated outdoor air.

# Piping Installation

## SUPPLY AND RETURN PIPING

Follow these piping guidelines:

1. Install a drain valve at the base of each supply and return riser to facilitate system flushing.
2. Install shutoff/balancing valves and unions at each unit to permit unit removal for servicing.
3. Place strainers at the inlet of each system circulating pump.
4. Select the proper hose length to allow slack between connection points. Hoses may vary in length by +2% to -4% under pressure.
5. Refer to the **Metal Hose Minimum Bend Radius** table. Do not go below the minimum bend radius for the hose selected. Going below the minimum bend radius may cause the hose to collapse, which reduces water flow rate. Install an angle adapter to avoid sharp bends in the hose when the radius falls below the required minimum.

Insulation is not required on loop water piping except where the piping runs through unheated areas, outside the building or when the loop water temperature is below the minimum expected dew point of the pipe ambient conditions. Insulation is required if loop water temperature drops below the dew point (insulation is required for ground loop applications in most climates).

Pipe joint compound is not necessary when water thread sealant tape is pre-applied to hose assemblies or when flared-end connections are used. If pipe joint compound is preferred, use compound only in small amounts on the external pipe threads of the fitting adapters. Prevent sealant from reaching the flared surfaces of the joint.

**NOTE: When antifreeze is used in the water loop, ensure that it is compatible with the thread-sealant tape or pipe-joint compound that is applied.**

Maximum allowable torque for brass fittings is 30 ft-lbs (41 N-m). If a torque wrench is not available, tighten finger-tight plus one quarter turn. Tighten steel fittings as necessary.

Optional pressure-rated hose assemblies designed specifically for use with units are available. Similar hoses can be obtained from alternate suppliers. Supply and return hoses are fitted with swivel-joint fittings at one end to prevent kinking during installation.

The **Supply/Return Hose Kit** figure illustrates a typical hose kit used in these applications. Adapters secure hose assemblies to the unit and risers. Install hose assemblies properly and check regularly to avoid system failure and reduced service life.

### WARNING

Polyolester Oil, commonly known as POE oil, is a synthetic oil used in many refrigeration systems including those with R-454B refrigerant. POE oil, if it ever comes in contact with PVC or CPVC piping, may cause failure of the PVC/CPVC. PVC/CPVC piping should never be used as supply or return water piping with water-source heat pump products containing R-454B as system failures and property damage may result.

### CAUTION

Corrosive system water requires corrosion resistant fittings and hoses, and may require water treatment.

### CAUTION

Do not bend or kink supply lines or hoses.

**Table 2: Metal Hose Minimum Bend Radius**

Hose Diameter	Minimum Bend Radius
1/2" [12.7 mm]	2-1/2" [6.4 cm]
3/4" [19.1 mm]	4" [10.2 cm]
1" [25.4 mm]	5-1/2" [14 cm]
1-1/4" [31.8 mm]	6-3/4" [17.1 cm]

### ATTENTION

Do not allow hoses to rest against structural building components. Compressor vibration may be transmitted through the hoses to the structure, causing unnecessary noise complaints.

**Figure 8: Supply/Return Hose Kit**

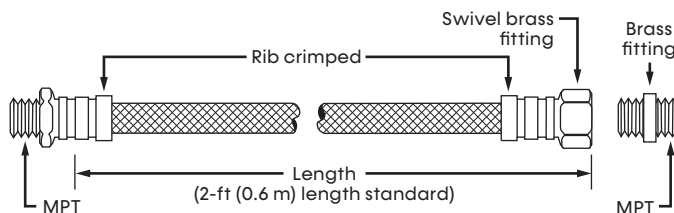

Models:  
MB  
072-300

# Applications Water-Loop Heat Pump

## COMMERCIAL WATER-LOOP APPLICATIONS

Commercial systems typically include a number of units connected to a common piping system. Any unit plumbing maintenance work can introduce air into the piping system; therefore air elimination equipment is a major portion of the mechanical room plumbing. To avoid condensation, consider insulating the piping surfaces. The manufacturer recommends piping insulation any time the water temperature is below 60°F (15.6°C). Do not use metal to plastic threaded joints due to their tendency to leak over time.

Water thread-sealant tape or thread sealant is recommended to minimize internal fouling of the heat exchanger. Do not over tighten connections and route piping so as not to interfere with service or maintenance access. Hose kits are available from the manufacturer in different configurations for connection between the unit and the piping system. Depending on selection, hose kits may include shutoff valves, P/T plugs for performance measurement, high pressure stainless-steel braided hose, “Y” type strainer with blow down valve, and/or with blow down valve, auto-flow valve and swivel connections.

Flush the piping system to remove dirt, piping chips, and other foreign material prior to operation. See the *Piping System Cleaning and Flushing* section for more

information. The flow rate is usually set between 2.25 and 3.5 GPM per ton (2.9 and 4.5 l/m per kW) of cooling capacity. The manufacturer recommends 3 GPM per ton (3.9 l/m per kW) for most water-loop heat pump applications. To ensure proper maintenance and servicing, P/T ports are imperative for temperature, flow verification, and performance checks.

Water-loop heat pump (cooling tower/boiler) systems typically utilize a common loop maintained between 60 - 90°F (16 - 32°C). The use of a closed-circuit evaporative cooling tower with a secondary heat exchanger between the tower and the water loop is recommended. If an open type cooling tower is used continuously, chemical treatment and filtering is necessary.

**⚠ WARNING**

Never jumper terminal “A” from CXM2 #1 to CXM2 #2 on multi-compressor/multi-control board units. For more information, see the motorized water valve wiring examples in the *Electrical Low-Voltage Wiring* section of this IOM.

**⚠ CAUTION**

Many units are installed with a factory or field-supplied manual or electric shutoff valve. **DAMAGE WILL OCCUR** if shutoff valve is closed during unit operation. A high-pressure switch must be installed on the heat pump side of any field-provided shutoff valves and connected to the heat pump controls in series with the built-in refrigerant circuit high pressure switch to disable compressor operation if water pressure exceeds pressure switch setting. The field-installed high pressure switch shall have a cut-out pressure of 300 psig and a cut-in pressure of 250 psig. You can order this pressure switch from the manufacturer with a 1/4-inch internal-flare connection as part number 39B0005N02.

**Figure 9: Typical Water-Loop Application**

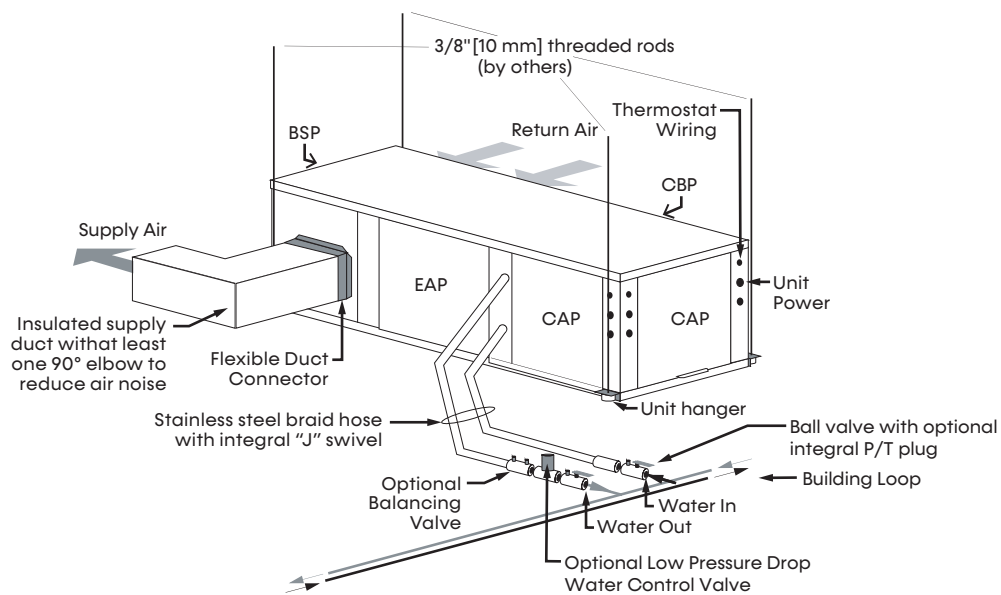

# Applications

## Ground-Loop Heat Pump Application

Models:  
MB  
072-300

### CAUTION

The following instructions represent industry accepted installation practices for closed loop earth coupled heat pump systems. Instructions are provided to assist the contractor in installing trouble free ground loops. These instructions are recommendations only. State/provincial and local codes MUST be followed and installation MUST conform to ALL applicable codes. It is the responsibility of the installing contractor to determine and comply with ALL applicable codes and regulations.

### CAUTION

Ground loop applications require extended range equipment and optional refrigerant/water circuit insulation.

Test individual horizontal loop circuits before backfilling. Test vertical U-bends and pond loop assemblies prior to installation. Use pressures of at least 100 psi (689 kPa) when testing. Do not exceed the pipe pressure rating. Test entire system when all loops are assembled.

## PRE-INSTALLATION

Prior to installation, locate and mark all existing underground utilities, piping, etc. Install loops for new construction before sidewalks, patios, driveways, and other construction has begun. During construction, accurately mark all ground loop piping on the plot plan as an aid in avoiding potential future damage to the installation.

## PIPING INSTALLATION

Limit all ground-loop piping materials to polyethylene fusion only for in-ground sections of the loop. Do not use galvanized or steel fittings at any time due to their tendency to corrode. Avoid all plastic-to-metal threaded fittings due to their potential to leak in ground-coupled applications. The manufacturer recommends using flanged fittings. Use P/T plugs to allow for flow measurement using the pressure drop of the unit heat exchanger.

Ground-loop temperatures can range between 25 and 110°F (-4 to 43°C). Flow rates between 2.25 and 3 GPM (2.41 to 3.23 l/m per kW) of cooling capacity is recommended in these applications.

**Table 3: Antifreeze Percentages by Volume**

Type	Minimum Antifreeze Concentration % for Low Temperature Protection			
	10°F [-12.2°C]	15°F [-9.4°C]	20°F [-6.7°C]	25°F [-3.9°C]
Methanol	21%	17%	13%	9%
100% USP food grade Propylene Glycol	29%	24%	19%	12%
Ethanol <sup>1</sup>	28%	24%	18%	12%

1. Must not be denatured with any petroleum based product

## FLUSHING THE GROUND LOOP

Upon completion of system installation and testing, flush the system to remove all foreign objects and purge to remove all air.

## ANTIFREEZE

For operation when water is used instead of an antifreeze solution, you must calculate the leaving water temperature (LWT). Flow must be maintained to a level such that the LWT is maintained above 40°F (4.4°C) when the JW3 jumper is not clipped. Otherwise, use appropriate levels of a proper antifreeze solution in systems with leaving water temperatures of 40°F (4.4°C) or below (or where piping is routed through areas subject to freezing) and clip the JW3 jumper. Alcohols and glycols are commonly used as antifreeze. Consult your local sales office to determine the antifreeze best suited to your area. Maintain freeze protection to 15°F (9°C) below the lowest expected entering loop temperature. For example, if 30°F (-1°C) is the minimum expected entering loop temperature, the leaving loop temperature would be 22 to 25°F (-6 to -4°C) and freeze protection should be at 15°F (-10°C).

Calculation is as follows:

$$30^{\circ}\text{F} - 15^{\circ}\text{F} = 15^{\circ}\text{F} \quad [-1^{\circ}\text{C} - 9^{\circ}\text{C} = -10^{\circ}\text{C}]$$

To prevent fumes, premix and pump alcohols from a reservoir outside of the building. If alcohols cannot be from outside the building, introduce them under the water level. Calculate the total volume of fluid in the piping system then use the **Antifreeze Percentages by Volume** table to determine the amount of antifreeze needed. Confirm antifreeze concentration in a homogeneous sample using a hydrometer or refractometer to measure specific gravity.

Models:  
MB  
072-300

# Applications

## Closed-Loop External Central Pumping

**Figure 10: Typical Closed-Loop with Central-Pumping Application**

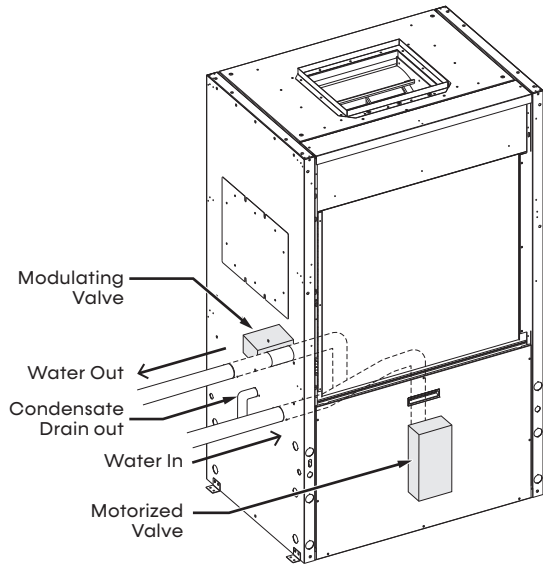

MB units are available with a modulating water valve option for closed-loop applications with external central pumping (designated by a C, or N in the 11th position of the unit model number). With this option, the Modulating Valve is regulated by the CXM2 Communicating Controls based on entering and leaving water temperature ( $\Delta T$ ). The CXM2 outputs a 0-10V signal to determine valve position (flow rate). The modulating valve defaults to closed position if it loses signal but still receives 24V power. If the motorized modulating valve loses both signal from the CXM2 AND 24V power, it remains in the same position as when it lost 24V power.

**NOTE:** The  $C_v$  (flow coefficient) of the valve used in these units is DIFFERENT than the  $C_v$  of the valve used in the open loop unit. It is not advisable for use in open loop applications as sound/noise issues may result. Units with the water circuit for closed-loop central-pumping option are only available with a copper water coil.

To manually open the internal modulating motorized water valve in MB vertical configurations, push down on the lock-release button while turning the handle to the open position as shown in the figure, Internal Modulating Motorized Valve Positions. This fully opens the valve for flushing. Once flushing is complete, press the lock release again and return the valve handle to its normally closed position.

**Figure 11: Internal Modulating Motorized Valve Positions**

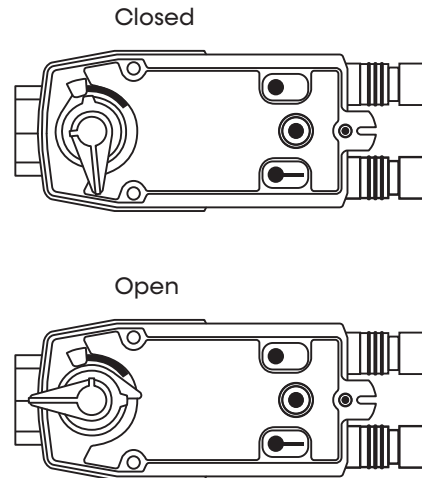

# Water Quality Requirements

**Table 4: Water Quality Requirements**

Clean water is essential to the performance and life span of water source heat pumps. Contaminants, chemicals, and minerals all have the potential to cause damage to the water heat exchanger if not treated properly. All closed-loop water systems should undergo water quality testing and be maintained to the water quality standards listed in this table. All open-loop water systems shall be tested upon installation and periodically to ensure water quality standard in the table below are met.

Water Quality Requirements For Closed-Loop and Open-Loop Systems							
	Description	Symbol	Units	Heat Exchanger Type			
				Closed Loop Recirculating		Open Loop, Tower, Ground Source Well	
				All Heat Exchanger Types	Coaxial HX Copper Tube in Tube	Coaxial HX Cupronickel	Brazed- Plate HX 316 SS
Scaling Potential	pH - Chilled Water <85°F			7.0 to 9.0	7.0 to 9.0	7.0 to 9.0	7.0 to 9.0
	pH - Chilled Water >85°F			8.0 to 10.0	8.0 to 10.0	8.0 to 10.0	8.0 to 10.0
	Alkalinity	(HCO <sub>3</sub> <sup>-</sup> )	ppm - CaCO <sub>3</sub> equivalent	50 to 500	50 to 500	50 to 500	50 to 500
	Calcium	(Ca)	ppm	<100	<100	<100	<100
	Magnesium	(Mg)	ppm	<100	<100	<100	<100
	Total Hardness	(CaCO <sub>3</sub> )	ppm - CaCO <sub>3</sub> equivalent	30 to 150	150 to 450	150 to 450	150 to 450
	Langelier Saturation Index	LSI		-0.5 to +0.5	-0.5 to +0.5	-0.5 to +0.5	-0.5 to +0.5
	Ryznar Stability Index	RSI		6.5 to 8.0	6.5 to 8.0	6.5 to 8.0	6.5 to 8.0
Corrosion Prevention	Total Dissolved Solids	(TDS)	ppm - CaCO <sub>3</sub> equivalent	<1000	<1000	<1000	<1000
	Sulfate	(SO <sub>4</sub> <sup>2-</sup> )	ppm	<200	<200	<200	<200
	Nitrate	(NO <sub>3</sub> <sup>-</sup> )	ppm	<100	<100	<100	<100
	Chlorine (free)	(Cl)	ppm	<0.5	<0.5	<0.5	<0.5
	Chloride (water < 80°F)	(Cl <sup>-</sup> )	ppm	<20	<20	<150	<150
	Chloride (water > 120°F)	(Cl <sup>-</sup> )	ppm	<20	<20	<125	<125
	Hydrogen Sulfide <sup>a</sup>	(H <sub>2</sub> S)	ppb	<0.5	<0.5	<0.5	<0.5
	Carbon Dioxide	(CO <sub>2</sub> )	ppm	0	<50	10 to 50	10 to 50
	Iron Oxide	(Fe)	ppm	<1.0	<1.0	<1.0	<0.2
	Manganese	(Mn)	ppm	<0.4	<0.4	<0.4	<0.4
	Ammonia	(NH <sub>3</sub> )	ppm	<0.05	<0.1	<0.1	<0.1
	Chloramine	(NH <sub>2</sub> CL)	ppm	0	0	0	0
Fouling & Biological	Iron bacteria		cells/mL	0	0	0	0
	Slime-forming bacteria		cells/mL	0	0	0	0
	Sulfate-reducing bacteria		cells/mL	0	0	0	0
	Suspended Solids <sup>b</sup>	(TSS)	ppm	<10	<10	<10	<10
Electrolysis All HX types	Earth Ground Resistance <sup>x</sup>		Ohms	Consult NEC and local electrical codes for grounding requirements			
	Electrolysis Voltage <sup>d</sup>		mV	Measure voltage and internal water loop to HP ground			
	Leakage Current <sup>e</sup>		mA	Measure current in water loop pipe			
	Building Primary Electrical Ground to unit, must meet local diameter and penetration length requirements. Do not connect heat pump to steel pipe unless dissimilar materials are separated by using Di-electric unions. Galvanic corrosion of heat pump water pipe will occur						

Models:  
MB  
072-300

## Water Quality Requirements

1. The **Water Quality Requirements** table provides water quality requirements for coaxial and brazed-plate heat exchangers.
2. The water must be evaluated by an independent testing facility comparing site samples against this table. When water properties are outside of these parameters, the water must either be treated by a professional water treatment specialist to bring the water quality within the boundaries of this specification, or an external secondary heat exchanger must be used to isolate the heat pump water system from the unsuitable water. Failure to do so will void the warranty of the heat pump system and will limit liability for damage caused by leaks or system failure.
3. Regular sampling, testing and treatment of the water is necessary to assure that the water quality remains within acceptable levels thereby allowing the heat pump to operate at optimum levels.
4. If closed-loop systems are turned off for extended periods, water samples must be tested prior to operating the system.
5. For optimal performance, it is recommended that the closed-loop piping systems are initially filled with deionized water.
6. Well water with chemistry outside of these boundaries, and salt water or brackish water requires an external secondary heat exchanger. Surface/Pond water should not be used.
7. If water temperature is expected to fall below 40°F (4.4°C), antifreeze is required. Refer to the heat pump IOM for the correct solution ratios to prevent freezing.
  - α Hydrogen sulfide has an odor of rotten eggs. If one detects this smell, a test for H<sub>2</sub>S must be performed. If H<sub>2</sub>S is detected above the limit indicated, remediation is necessary. Consult with your water testing/treatment professional. If a secondary heat exchanger is required, use appropriate materials as recommended by the heat exchanger supplier.
  - β Suspended solids and particulates must be filtered to prevent fouling and failure of heat exchangers. Strainers or particulate filters must be installed to provide a maximum particle size of 600 micron (0.60 mm, 0.023 inch) using a 20 to 30 mesh screen size. When a loop is installed in areas with fine material such as sand or clay, further filtration is required to a maximum of 100 micron. Refer to the Strainer / Filter Sizing Chart to capture the particle sizes encountered on the site.
  - χ The WSHP piping system or other plumbing pipes must not be used as the building ground. An electrical grounding system using a dedicated ground rod meeting NEC and local electrical codes must be installed.
  - δ Refer to the **Antifreeze Percentages by Volume** table for instructions on measuring resistance and leakage currents within water loops.

**Strainer / Filter Sizing**

Mesh Size	Particle Size		
	Microns	Millimeter	Inch
20	840	0.840	0.0340
30	533	0.533	0.0210
60	250	0.250	0.0100
100	149	0.149	0.0060
150	100	0.100	0.0040
200	74	0.074	0.0029

- ppm = parts per million
- ppb = parts per billion

# Water Quality Requirements

## Measuring Electrolysis, Voltage, and Current for Ground-Water Applications

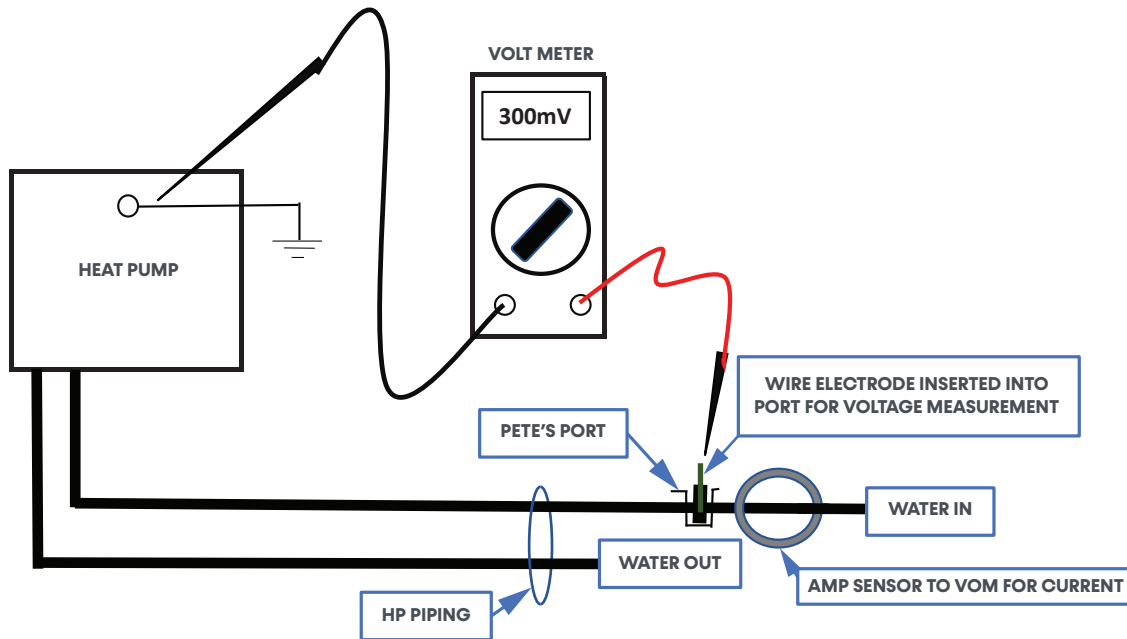

- Measure the electrolysis voltage using a volt meter between the heat pump ground and a #14 AWG solid copper wire electrode inserted into the water using a Pete's style access port.
- The heat pump must be operating and the water stream flowing.
- The voltage measured should be less than 300mV (0.300V). If the voltage is higher than 500mV, electrolysis occurs resulting in corrosion.
- If voltage is measured, the cause is a high-resistance earth ground or current on the neutral conductor. Remedial measures should be performed.
- Measure the current flowing through the piping system by using an amp clamp probe on the water-in line. The heat pump must be operating and the water stream flowing.
- There should be zero amps measured. If current is present, there is leakage current to the plumbing system and it must be rectified to prevent pipe corrosion.

## Measuring Earth Ground Resistance

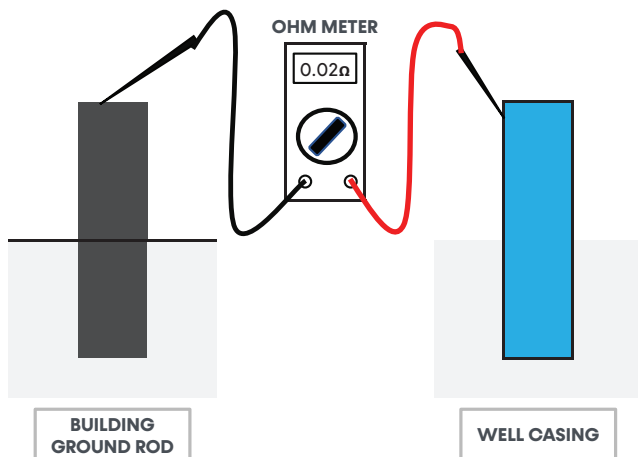

- Measure the earth ground bond using an Ohm meter between the building's ground rod and the steel well casing.
- The resistance measured should be zero Ohms. The NEC allows a resistance to ground up to 20 Ohms. Any resistance above zero indicates a poor earth ground, which may be the result of a hot neutral line or that conductive water is present. Both of these may lead to electrolysis and corrosion of the heat pump piping. A check for both should be performed and resolved.

**NOTE: If the well casing is plastic, create a conductive path by inserting a #6 AWG bare copper wire into the well water. Remove the temporary conductor when finished.**

Models:  
MB  
072-300

# Electrical Data Standard

Model	Voltage Code	Voltage	Min/Max Voltage	Blower Option	Compressor			Fan Motor FLA	Rated Current Amps	Min Circuit Amps	SCCR kA RMS Symetrical	SCCR Volts Maximum	Max Fuse HACR Amps
					Qty	RLA	LRA						
MB072	K	208/230-3-60	187/252	1,2,3	2	12.2	97.5	3.0	27.4	30.5	5	600	40
				4,5	2	12.2	97.5	5.8	30.2	33.3	5	600	45
				6	2	12.2	97.5	6.0	30.4	33.5	5	600	45
	L	460-3-60	432/504	1,2,3	2	5.8	44.3	1.4	13.0	14.5	5	600	20
				4,5	2	5.8	44.3	2.9	14.5	16.0	5	600	20
				6	2	5.8	44.3	4.6	16.2	17.7	5	600	20
	M	575-3-60	540/630	1,2,3	2	4.5	27.1	1.2	10.2	11.3	5	600	15
				4,5	2	4.5	27.1	2.2	11.2	12.3	5	600	15
	MB096	K	208/230-3-60	187/252	1,2,3	2	12.8	120.4	5.8	31.4	34.6	5	600
4,5					2	12.8	120.4	8.2	33.8	37.0	5	600	45
6					2	12.8	120.4	16.0	41.6	45.6	5	600	60
L		460-3-60	432/504	1,2,3	2	6.0	49.4	2.9	14.9	16.4	5	600	20
				4,5	2	6.0	49.4	4.1	16.1	17.6	5	600	20
				6	2	6.0	49.4	6.9	18.9	20.6	5	600	25
M		575-3-60	540/630	1,2,3	2	5.8	41.0	2.2	13.8	15.3	5	600	20
				4,5	2	5.8	41.0	3.2	14.8	16.3	5	600	20
MB120		K	208/230-3-60	187/252	1,2,3	2	18.6	155.0	8.2	45.4	50.1	5	600
	4,5				2	18.6	155.0	14.0	51.2	55.9	5	600	70
	6				2	18.6	155.0	20.3	57.5	62.6	5	600	80
	L	460-3-60	432/504	1,2,3	2	8.3	58.1	4.1	20.7	22.8	5	600	30
				4,5	2	8.3	58.1	6.5	23.1	25.2	5	600	30
				6	2	8.3	58.1	10.3	26.9	29.5	5	600	35
	M	575-3-60	540/630	1,2,3	2	7.7	47.8	3.2	18.6	20.5	5	600	25
				4,5	2	7.7	47.8	5.2	20.6	22.5	5	600	30
	MB168	K	208/230-3-60	187/252	1,2,3	2	24.4	200.0	8.2	57.0	63.1	5	600
4,5					2	24.4	200.0	14.0	62.8	68.9	5	600	90
6					2	24.4	200.0	10.0	58.8	64.9	5	600	80
L		460-3-60	432/504	1,2,3	2	11.9	103.0	4.1	27.9	30.9	5	600	40
				4,5	2	11.9	103.0	6.5	30.3	33.3	5	600	45
				6	2	11.9	103.0	10.3	34.1	37.1	5	600	45
M		575-3-60	540/630	1,2,3	2	9.4	78.0	3.2	22.0	24.4	5	600	30
				4,5	2	9.4	78.0	5.2	24.0	26.4	5	600	35

Table continued on next page.

# Electrical Data Standard

Models:  
MB  
072-300

Table continued from previous page.

Model	Voltage Code	Voltage	Min/Max Voltage	Blower Option	Compressor			Fan Motor FLA	Rated Current Amps	Min Circuit Amps	SCCR kA RMS Symmetrical	SCCR Volts Maximum	Max Fuse HACR Amps
					Qty	RLA	LRA						
MB192	K	208/230-3-60	187/252	1,2,3	2	27.7	178.5	8.2	63.6	70.5	5	600	90
				4,5	2	27.7	178.5	14.0	69.4	76.3	5	600	100
				6	2	27.7	178.5	20.3	75.7	82.6	5	600	110
	L	460-3-60	432/504	1,2,3	2	11.5	103.0	4.1	27.1	30.0	5	600	40
				4,5	2	11.5	103.0	6.5	29.5	32.4	5	600	40
				6	2	11.5	103.0	10.3	33.3	36.2	5	600	45
	M	575-3-60	540/630	1,2,3	2	9.0	78.0	3.2	21.2	23.5	5	600	30
				4,5	2	9.0	78.0	5.2	23.2	25.5	5	600	30
	MB240	K	208/230-3-60	187/252	1,2,3	2	28.5	255.0	14.0	71.0	78.1	5	600
4,5					2	28.5	255.0	20.6	77.6	84.7	5	600	110
6					2	28.5	255.0	30.5	87.5	95.1	5	600	125
L		460-3-60	432/504	1,2,3	2	13.5	123.0	6.5	33.5	36.9	5	600	50
				4,5	2	13.5	123.0	9.8	36.8	40.2	5	600	50
				6	2	13.5	123.0	14.8	41.8	45.5	5	600	60
M		575-3-60	540/630	1,2,3	2	10.7	93.7	5.2	26.6	29.3	5	600	35
				4,5	2	10.7	93.7	8.0	29.4	32.1	5	600	40
MB300		K	208/230-3-60	187/252	1,2,3	2	40.8	270.0	20.6	102.2	112.4	5	600
	4,5				2	40.8	270.0	26.8	108.4	118.6	5	600	150
	6				2	40.8	270.0	25.0	106.6	116.8	5	600	150
	L	460-3-60	432/504	1,2,3	2	19.4	147.0	9.8	48.6	53.5	5	600	70
				4,5	2	19.4	147.0	12.7	51.5	56.4	5	600	70
				6	2	19.4	147.0	20.3	59.1	64.2	5	600	80
	M	575-3-60	540/630	1,2,3	2	13.7	109.0	8.0	35.4	38.8	5	600	50
				4,5	2	13.7	109.0	10.0	37.4	40.8	5	600	50

Models:  
MB  
072-300

# Electrical Data Dual Point Power

Model	Voltage Code	Voltage	Min/Max Voltage	Blower Option	Compressor Power Supply							Fan Power Supply					
					Qty	RLA	LRA	Rated Current Amps	Min Circuit Amps	SCCR kA RMS Symmetrical	SCCR Volts Max	Max Fuse HACR Amps	Fan Motor FLA	Min Circuit Amps	SCCR kA RMS Symmetrical	SCCR Volts Max	Max Fuse HACR Amps
MB072	K	208/230-3-60	187/252	A,B,C	2	12.2	97.5	24.4	27.5	5	600	35	3.0	3.8	5	600	15
				D,E	2	12.2	97.5	24.4	27.5	5	600	35	5.8	7.3	5	600	15
				F	2	12.2	97.5	24.4	27.5	5	600	35	6.0	7.5	5	600	15
	L	460-3-60	432/504	A,B,C	2	5.8	44.3	11.6	13.1	5	600	15	1.4	1.8	5	600	15
				D,E	2	5.8	44.3	11.6	13.1	5	600	15	2.9	3.6	5	600	15
				F	2	5.8	44.3	11.6	13.1	5	600	15	4.6	5.8	5	600	15
	M	575-3-60	540/630	A,B,C	2	4.5	27.1	9.0	10.1	5	600	15	1.2	1.5	5	600	15
				D,E	2	4.5	27.1	9.0	10.1	5	600	15	2.2	2.8	5	600	15
	MB096	K	208/230-3-60	187/252	A,B,C	2	12.8	120.4	25.6	28.8	5	600	40	5.8	7.3	5	600
D,E					2	12.8	120.4	25.6	28.8	5	600	40	8.2	10.3	5	600	15
F					2	12.8	120.4	25.6	28.8	5	600	40	16.0	20.0	5	600	35
L		460-3-60	432/504	A,B,C	2	6.0	49.4	12.0	13.5	5	600	15	2.9	3.6	5	600	15
				D,E	2	6.0	49.4	12.0	13.5	5	600	15	4.1	5.1	5	600	15
				F	2	6.0	49.4	12.0	13.5	5	600	15	6.9	8.6	5	600	15
M		575-3-60	540/630	A,B,C	2	5.8	41	11.6	13.1	5	600	15	2.2	2.8	5	600	15
				D,E	2	5.8	41	11.6	13.1	5	600	15	3.2	4.0	5	600	15
MB120		K	208/230-3-60	187/252	A,B,C	2	18.6	155	37.2	41.9	5	600	60	8.2	10.3	5	600
	D,E				2	18.6	155	37.2	41.9	5	600	60	14.0	17.5	5	600	30
	F				2	18.6	155	37.2	41.9	5	600	60	20.3	25.4	5	600	45
	L	460-3-60	432/504	A,B,C	2	8.3	58.1	16.6	18.7	5	600	25	4.1	5.1	5	600	15
				D,E	2	8.3	58.1	16.6	18.7	5	600	25	6.5	8.1	5	600	15
				F	2	8.3	58.1	16.6	18.7	5	600	25	10.3	12.9	5	600	20
	M	575-3-60	540/630	A,B,C	2	7.7	47.8	15.4	17.3	5	600	25	3.2	4.0	5	600	15
				D,E	2	7.7	47.8	15.4	17.3	5	600	25	5.2	6.5	5	600	15

Table continued on next page.

# Electrical Data Dual Point Power

Models:  
MB  
072-300

Table continued from previous page.

Model	Voltage Code	Voltage	Min/Max Voltage	Blower Option	Compressor Power Supply							Fan Power Supply					
					Qty	RLA	LRA	Rated Current Amps	Min Circuit Amps	SCCR kA RMS Symmetrical	SCCR Volts Max	Max Fuse HACR Amps	Fan Motor FLA	Min Circuit Amps	SCCR kA RMS Symmetrical	SCCR Volts Max	Max Fuse HACR Amps
MB168	K	208/230-3-60	187/252	A,B,C	2	24.4	200	48.8	54.9	5	600	70	8.2	10.3	5	600	15
				D,E	2	24.4	200	48.8	54.9	5	600	70	14.0	17.5	5	600	30
				F	2	24.4	200	48.8	54.9	5	600	70	10.0	12.5	5	600	20
	L	460-3-60	432/504	A,B,C	2	11.9	103	23.8	26.8	5	600	35	4.1	5.1	5	600	15
				D,E	2	11.9	103	23.8	26.8	5	600	35	6.5	8.1	5	600	15
				F	2	11.9	103	23.8	26.8	5	600	35	10.3	12.9	5	600	20
	M	575-3-60	540/630	A,B,C	2	9.4	78	18.8	21.2	5	600	30	3.2	4.0	5	600	15
				D,E	2	9.4	78	18.8	21.2	5	600	30	5.2	6.5	5	600	15
	MB192	K	208/230-3-60	187/252	A,B,C	2	27.7	178.5	55.4	62.3	5	600	90	8.2	10.3	5	600
D,E					2	27.7	178.5	55.4	62.3	5	600	90	14.0	17.5	5	600	30
F					2	27.7	178.5	55.4	62.3	5	600	90	20.3	25.4	5	600	45
L		460-3-60	432/504	A,B,C	2	11.5	103	23.0	25.9	5	600	35	4.1	5.1	5	600	15
				D,E	2	11.5	103	23.0	25.9	5	600	35	6.5	8.1	5	600	15
				F	2	11.5	103	23.0	25.9	5	600	35	10.3	12.9	5	600	20
M		575-3-60	540/630	A,B,C	2	9.0	78	18.0	20.3	5	600	25	3.2	4.0	5	600	15
				D,E	2	9.0	78	18.0	20.3	5	600	25	5.2	6.5	5	600	15
MB240		K	208/230-3-60	187/252	A,B,C	2	28.5	255	57.0	64.1	5	600	90	14.0	17.5	5	600
	D,E				2	28.5	255	57.0	64.1	5	600	90	20.6	25.8	5	600	45
	F				2	28.5	255	57.0	64.1	5	600	90	30.5	38.1	5	600	60
	L	460-3-60	432/504	A,B,C	2	13.5	123	27.0	30.4	5	600	40	6.5	8.1	5	600	15
				D,E	2	13.5	123	27.0	30.4	5	600	40	9.8	12.3	5	600	20
				F	2	13.5	123	27.0	30.4	5	600	40	14.8	18.5	5	600	30
	M	575-3-60	540/630	A,B,C	2	10.7	93.7	21.4	24.1	5	600	30	5.2	6.5	5	600	15
				D,E	2	10.7	93.7	21.4	24.1	5	600	30	8.0	10.0	5	600	15
	MB300	K	208/230-3-60	187/252	A,B,C	2	40.8	270	81.6	91.8	5	600	125	20.6	25.8	5	600
D,E					2	40.8	270	81.6	91.8	5	600	125	26.8	33.5	5	600	60
F					2	40.8	270	81.6	91.8	5	600	125	25.0	31.3	5	600	50
L		460-3-60	432/504	A,B,C	2	19.4	147	38.8	43.7	5	600	60	9.8	12.3	5	600	20
				D,E	2	19.4	147	38.8	43.7	5	600	60	12.7	15.9	5	600	25
				F	2	19.4	147	38.8	43.7	5	600	60	20.3	25.4	5	600	45
M		575-3-60	540/630	A,B,C	2	13.7	109	27.4	30.8	5	600	40	8.0	10.0	5	600	15
				D,E	2	13.7	109	27.4	30.8	5	600	40	10.0	12.5	5	600	20

Models:  
MB  
072-300

# Electrical Power and Low-Voltage Wiring

## ELECTRICAL

**Line Voltage** - All field installed wiring, including electrical ground, must comply with NFPA 70: National Electrical Code (NEC), CSA C22.1: Canadian Electrical Code (CE Code), as well as applicable local codes. Refer to the unit electrical data for fuse sizes. Consult wiring diagram for field connections that must be made by the installing (or electrical) contractor. All final electrical connections must be made with a length of flexible conduit to minimize vibration and sound transmission to the building.

## GENERAL LINE-VOLTAGE WIRING

Be sure the available power is the same voltage and phase shown on the unit serial plate. Line- and low-voltage wiring must be done in accordance with local codes or the National Electric Code, whichever is applicable.

## TRANSFORMER

All 208/230V units are factory wired for 230V. If supply voltage is 208V, installer must rewire transformer. See the wiring diagram for connections.

## DISCONNECT

Units with a factory-installed disconnect switch will provide full separation of all poles and disconnection from main line voltage. For units where factory disconnect is not selected as an option, the installer must incorporate the means to fully disconnect the line voltage in the fixed wiring in accordance with wiring rules and local electrical codes.

## LOW WATER-TEMPERATURE CUTOUT SELECTION

The CXM2 allows the field selection of low-water (or water-antifreeze solution) temperature limit by clipping jumper JW3, which changes the sensing temperature associated with thermistor LT1. Note that the LT1 thermistor is located on the refrigerant line between the coaxial heat exchanger and expansion device (TXV or cap tube). Therefore, LT1 is sensing refrigerant temperature, not water temperature, which is a better indication of how water flow rate/temperature is affecting the refrigeration circuit.

Figure 12: LT1 Limit Setting

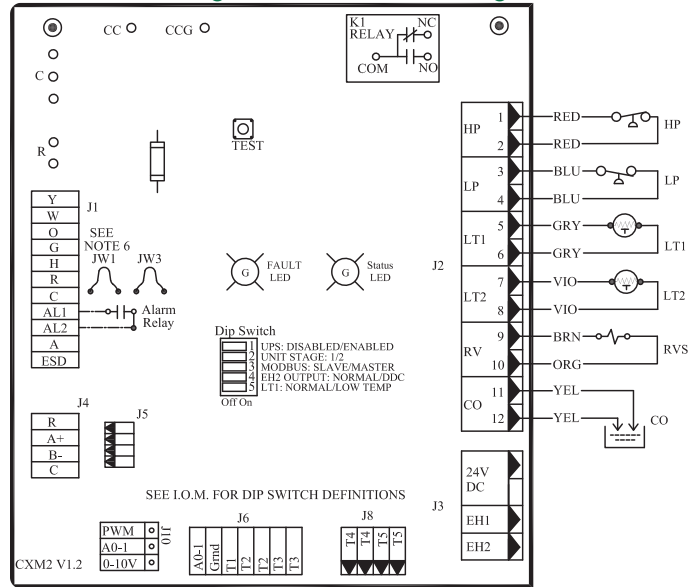

The factory setting for LT1 is for systems using water (30°F [-1.1°C] refrigerant temperature). In low water temperature (extended range) applications with antifreeze (most ground loops), clip the JW3 jumper as shown in the **LT1 Limit Setting** figure to change the setting to 10°F (-12.2°C) refrigerant temperature, a more suitable temperature when using an antifreeze solution. All MB units operating with entering water temperatures below 59°F (15°C) must include the optional water/refrigerant circuit insulation package to prevent internal condensation.

Figure 13: MB Horizontal Control Box (Representative)

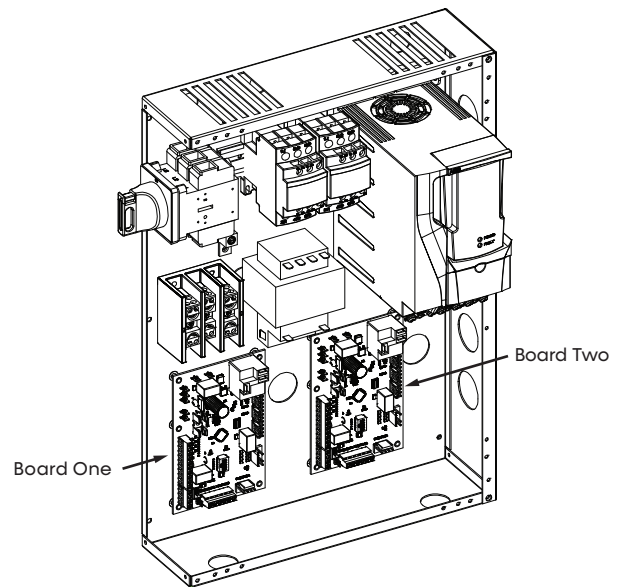

# Electrical Example Wiring Diagram

Models:  
MB  
072-300

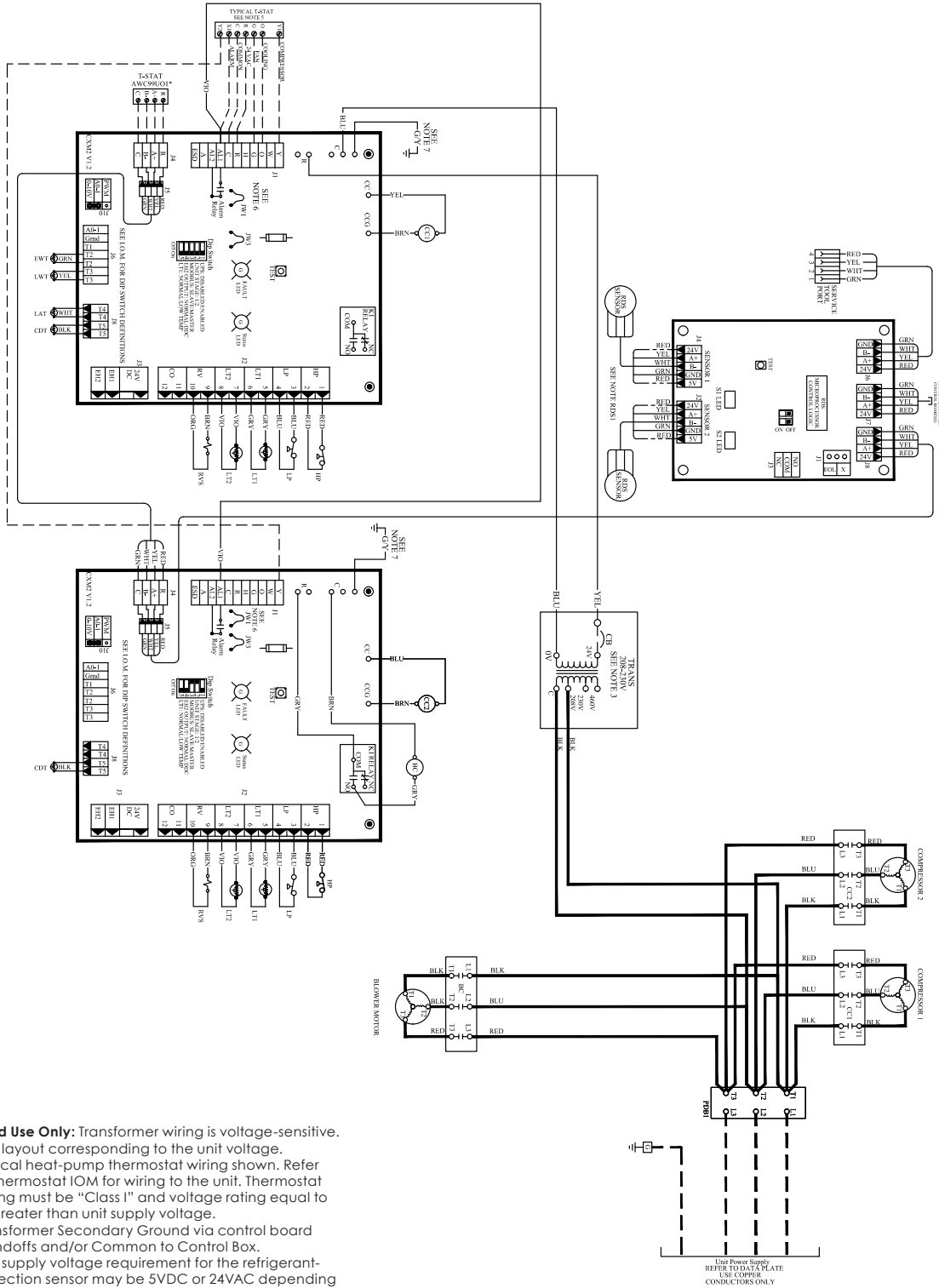

**NOTES:**

1. **Field Use Only:** Transformer wiring is voltage-sensitive. Use layout corresponding to the unit voltage.
2. Typical heat-pump thermostat wiring shown. Refer to thermostat IOM for wiring to the unit. Thermostat wiring must be "Class 1" and voltage rating equal to or greater than unit supply voltage.
3. Transformer Secondary Ground via control board standoffs and/or Common to Control Box.
4. The supply voltage requirement for the refrigerant-detection sensor may be 5VDC or 24VAC depending on the type of sensor provided by the manufacturer.

Models:  
MB  
072-300

# Electrical Example VFD Wiring Diagram

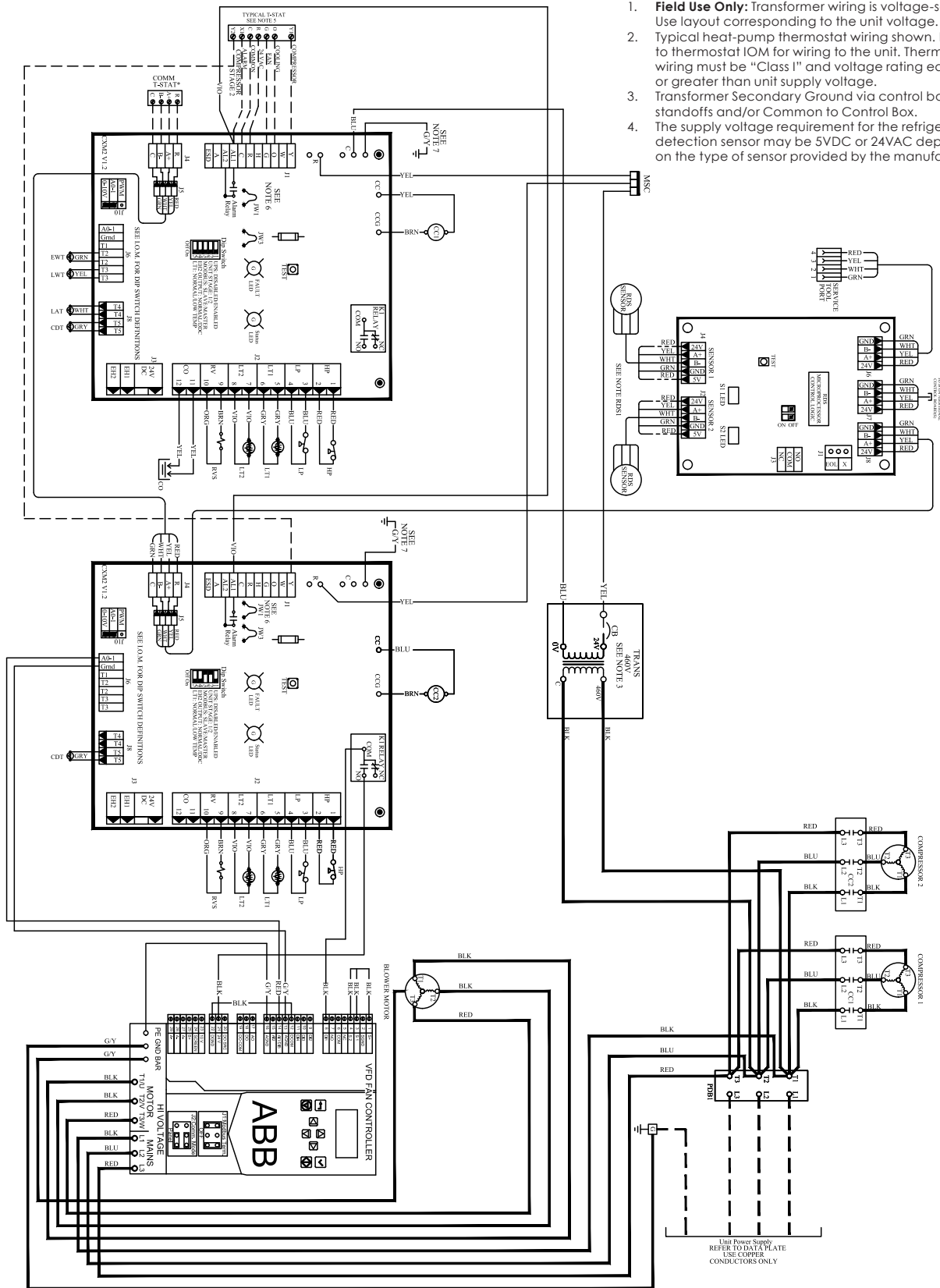

**NOTES:**

1. **Field Use Only:** Transformer wiring is voltage-sensitive. Use layout corresponding to the unit voltage.
2. Typical heat-pump thermostat wiring shown. Refer to thermostat IOM for wiring to the unit. Thermostat wiring must be "Class I" and voltage rating equal to or greater than unit supply voltage.
3. Transformer Secondary Ground via control board standoffs and/or Common to Control Box.
4. The supply voltage requirement for the refrigerant-detection sensor may be 5VDC or 24VAC depending on the type of sensor provided by the manufacturer.

# Electrical VFD EMC and VAR Screws

Models:  
MB  
072-300

While installing MB units configured with a VFD-powered blower, ensure that the drive is compatible with the grounding system.

You can connect all drive types to a symmetrically grounded TN-S system (center-grounded wye). The drive is delivered with the EMC and VAR screws installed.

The screw material is plastic or metal depending on the product variant. The **VFD Screw Removal** table details when to remove the metal EMC screw (disconnect the internal EMC filter) or metal VAR screw (disconnect the varistor circuit).

**Table 5: VFD Screw Identification**



**Table 6: VFD Screw Removal**

Screw Label	Factory Default Screw Material	Grounding Systems		
		Symmetrically Grounded TN-S (center-grounded wye) Systems	Corner-Grounded Delta, Midpoint-Grounded Delta, and IT Systems	IT Systems (ungrounded or high-resistance grounded)
EMC	Metal	Do not remove	Remove	Remove
	Plastic	Do not remove <sup>2</sup>	Do not remove	Do not remove
VAR	Metal	Do not remove	Do not remove	Remove
	Plastic	Do not remove	Do not remove	Do not remove

1. Drives sold in North America have a plastic EMC screw.  
 2. You can install the metal screw (included in the drive delivery) to connect the internal EMC filter.

Models:  
MB  
072-300

# Electrical Low-Voltage Wiring

## MODELS WITH WATERSIDE ECONOMIZER

Controller is factory assembled. Factory settings are 45°F (7.2°C), valve opens, closes at 55°F (12.8°C), and 5 minute short cycle delay. Settings are adjustable.

### ACCESSORY CONNECTIONS

A terminal paralleling the compressor contactor coil is provided on the CXM2. Terminal “A” is designed to control accessory devices, such as water valves.

**NOTE: Only use this terminal with 24V signals and not line voltage.** Terminal “A” is energized with the compressor contactor. See the specific unit wiring diagram for details.

**Table 7: Low Voltage VA Ratings**

Component	VA
Typical Blower Relay	6 - 7
Typical Reversing Valve Solenoid	4 - 6
30 A Compressor Contactor	6 - 9
Subtotal	16 - 22
+ CXM2 (5 - 9VA) <sup>1</sup>	21 - 31
Remaining VA for Accessories	19 - 29

1. Standard transformer for MB units is 100VA.

**Figure 14: Accessory Wiring**

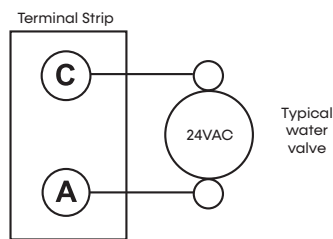

### CAUTION

Many units are installed with a factory or field-supplied manual or electric shut-off valve. **DAMAGE WILL OCCUR** if shut-off valve is closed during unit operation. A high-pressure switch must be installed on the heat-pump side of any field provided shut-off valves and connected to the heat-pump controls in series with the built-in refrigerant circuit high-pressure switch to disable compressor operation if water pressure exceeds pressure switch setting. The field-installed high-pressure switch shall have a cut-out pressure of 300 psig and a cut-in pressure of 250 psig. This pressure switch can be ordered from the manufacturer with a 1/4-inch internal flare connection as part number 39B0005N02.

## WATER SOLENOID VALVES

An external solenoid valve(s) should be used on ground water installations to shut off flow to the unit when the compressor is not operating. A slow closing valve may be required to help reduce water hammer. The **Accessory Wiring** figure shows typical wiring for a 24VAC external solenoid valve. The **Optional Motorized Water Valve Wiring** figure illustrates a slow-closing water control valve wiring for a style of typical accessory water valve. Slow-closing valves take approximately 60 seconds to open (very little water flows before 45 seconds). Once fully open, an end switch allows the compressor to be energized. Only relay or triac based electronic thermostats should be used with slow-closing valves. When wired as shown, the slow-closing valve operate properly with the following notations:

- The valve remains open during a unit lockout.
- The valve draws approximately 25-35VA through the “Y” signal of the thermostat.

**NOTE: This valve can overheat the anticipator of an electromechanical thermostat. Therefore, only relay or triac based thermostats should be used.**

**Figure 15: Optional Motorized Water Valve Wiring**

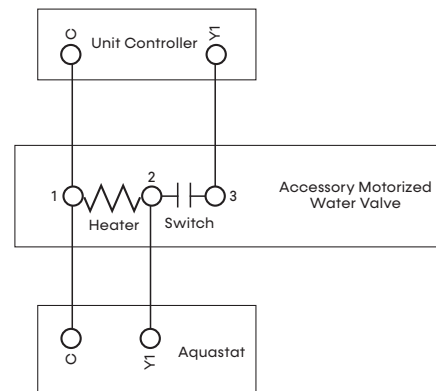

## THERMOSTAT CONNECTIONS

The thermostat should be wired directly to the CXM2. See *Electrical Thermostat Wiring* for specific terminal connections. Review the appropriate AOM (Application, Operation and Maintenance) manual for units with DDC controls.

# Electrical Thermostat Wiring

Models:  
MB  
072-300

## THERMOSTAT INSTALLATION

The thermostat should be located on an interior wall in a larger room, away from supply duct drafts. DO NOT locate the thermostat in areas subject to sunlight, drafts or on external walls. The wire access hole behind the thermostat may in certain cases need to be sealed to prevent erroneous temperature measurement.

Position the thermostat back plate against the wall so that it appears level and so the thermostat wires protrude through the middle of the back plate. Mark

the position of the back plate mounting holes and drill holes with a 3/16-inch (5-mm) bit. Install supplied anchors and secure plate to the wall.

Thermostat wire must be 18 AWG wire. Wire the appropriate thermostat as shown in the **Thermostat Wiring** figure to the low-voltage terminal strip on the CXM2. Most heat pump thermostats are compatible with heat pump units provided they have the correct number of heating and cooling stages.

**Figure 16: Thermostat Connection**

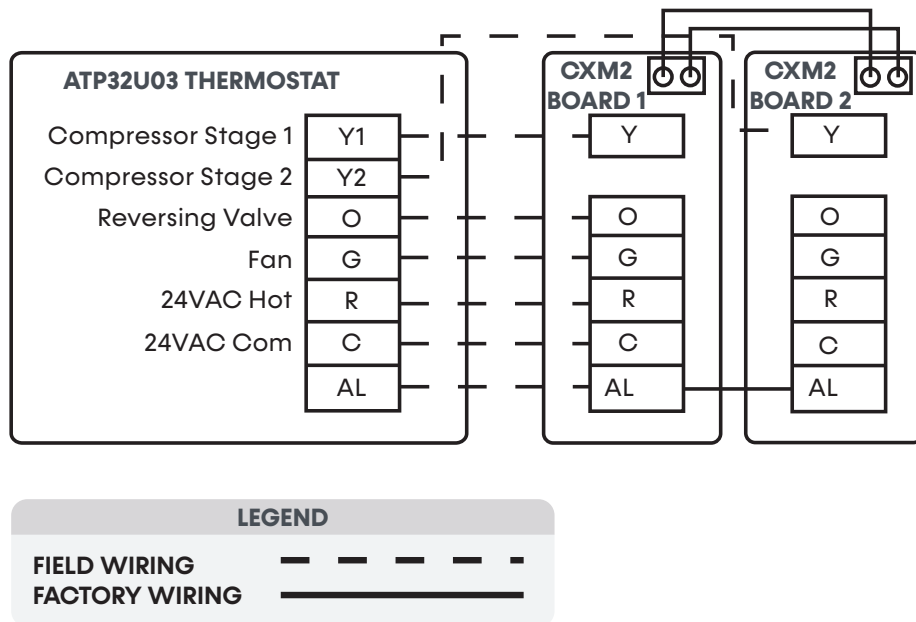

Models:  
MB  
072-300

# Electrical External Pump Control

**Figure 17: External Pump Control Diagram**

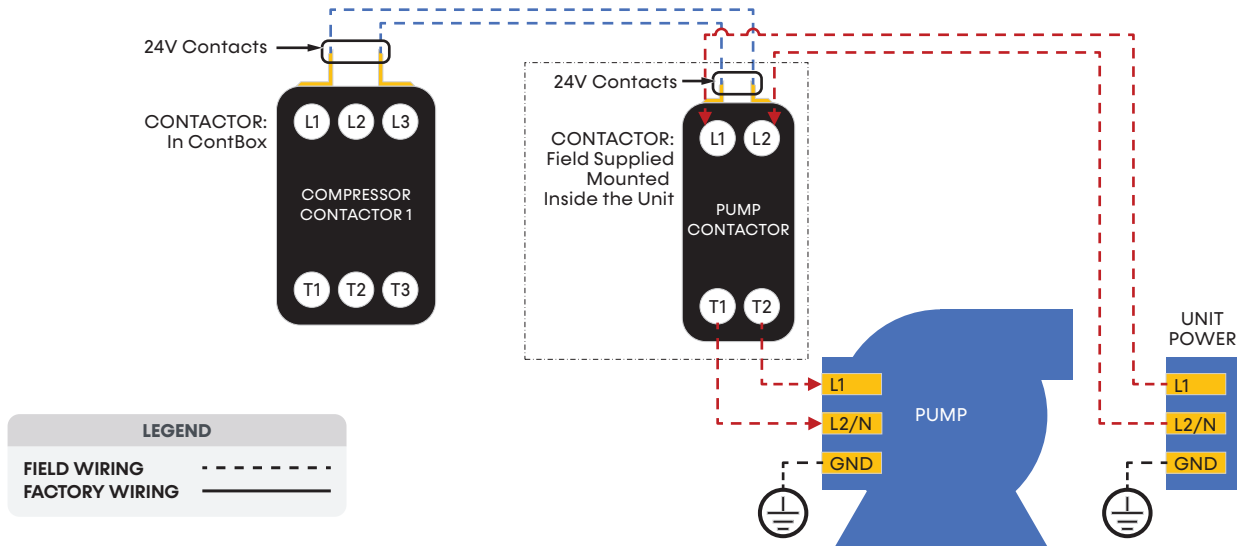

**Figure 18: External Pump Control with VFD Diagram**

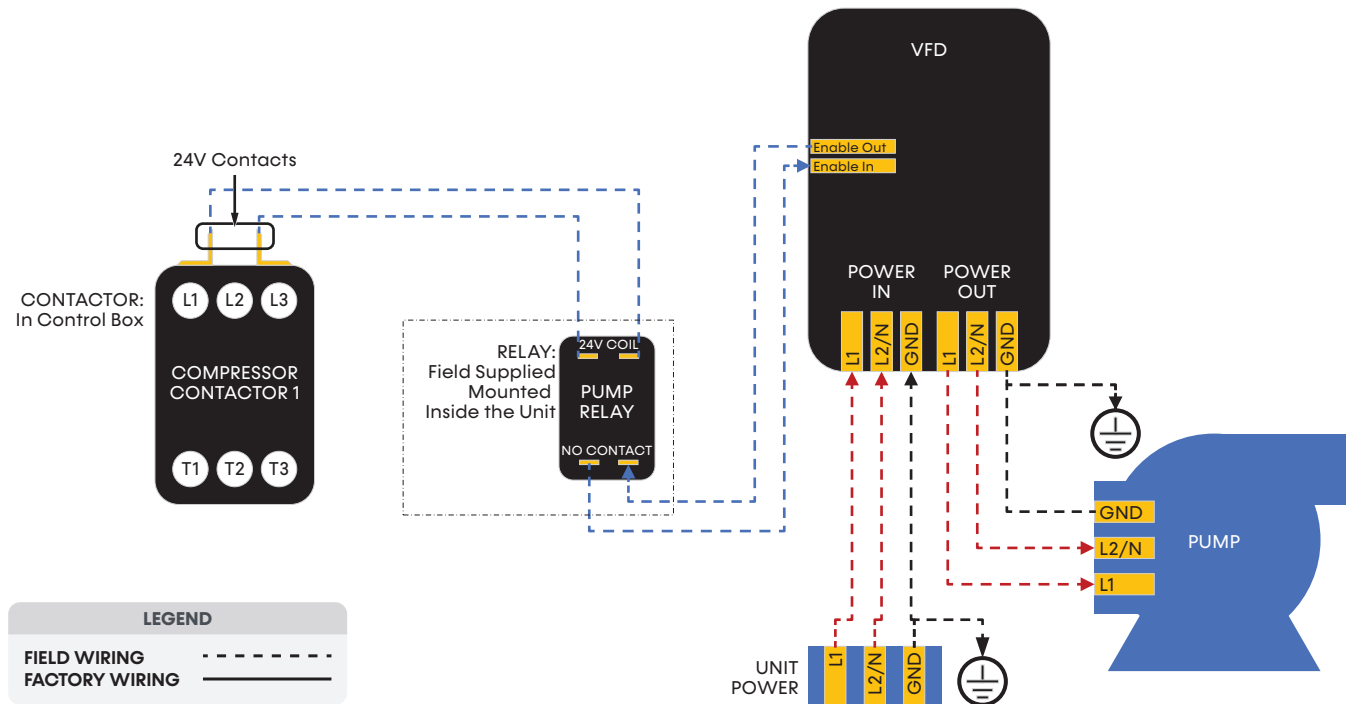

# Electrical Refrigerant Detection System

Models:  
MB  
072-300

## REFRIGERANT DETECTION SYSTEM (RDS)

The function, operation, and required servicing measures for the Refrigerant Detection System (RDS) include the following:

- The RDS monitors the status of the refrigerant sensor(s) in the unit. If refrigerant is detected above the maximum threshold, the control enables the unit blower, disables the compressor(s), and enables the pilot relay on the RDS control board. You can use this relay to open external zoning dampers and/or activate external mechanical ventilation. The relay is normally closed (NC) and can control a signal with a maximum of 28VA @ 24VAC.
- A fault is enabled if the RDS control board loses communication with a refrigerant sensor or if the main control board loses communication with the RDS board. See Functional Troubleshooting for steps to troubleshoot the RDS.
- The End of Line (EoL) termination is used to prevent signal reflection issues in the communication network. When the EoL termination is enabled, it places a resistor at the end of the communication line, ensuring proper signal integrity and reducing potential communication errors. Add the EoL termination resistor when the RDS board is the end of a daisy-chain, and the total length of the wire is greater than 50 feet.

Figure 19: RDS Board

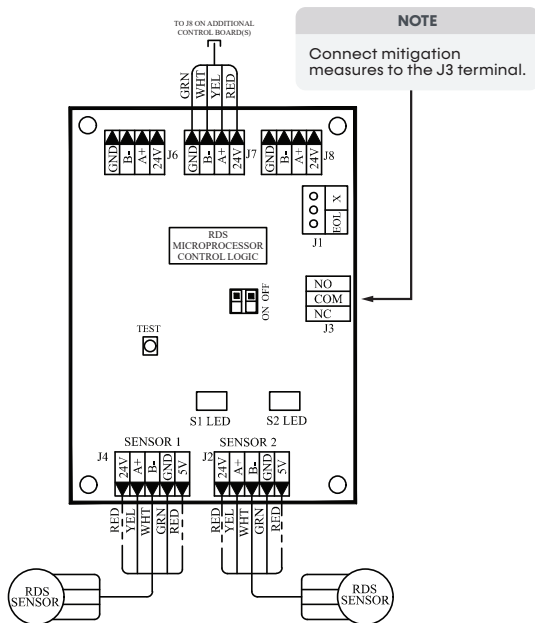

## RDS SENSOR PLACEMENT

Large vertical units come standard with factory-installed RDS. There are two sensors included: One in the compressor section, and one in the blower section. The RDS board is mounted on the control box cover.

If a sensor needs to be replaced, consult the RDS AOM. The manufacturer utilizes two brands of sensors, and each sensor has a specific connector. However, you can mix sensors without issue in the field.

### ⚠ ATTENTION

The sensors cannot be installed in a way that exposes it to water. Install them using the orientation displayed in the **RDS Sensor Installation** figures.

Figure 20: RDS Sensor Installation



Figure 21: RDS Sensor Installation



Models:  
MB  
072-300

## Electrical CXM2, RDS, and Wireless Service Tool



### **CXM2 Communicating Controls**

For detailed controller information, see the CXM2 Application, Operation, and Maintenance (AOM) manual (part # 97B0137N01). To confirm the controller type of your particular unit, refer to digit 9 on the unit model number and the unit nomenclature diagram found on page 3 of this manual.



### **Refrigerant Detection System**

For detailed controller information, see the Refrigerant Detection System Application, Operation, and Maintenance (AOM) manual (part # 97B0152N01).



### **Wireless Service Tool**

For detailed controller information, see the Wireless Service Tool Application, Operation, and Maintenance (AOM) manual (part # 97B0169N01). The Wireless Service Tool port is located on the corner post of most models.

## Blower Adjustment

### CAUTION

Always disconnect all power supply(s) to unit prior to making belt or sheave adjustments. Inadvertently starting of the motor can cause damage to the equipment and personal injury.

## AIRFLOW AND EXTERNAL STATIC PRESSURE

### Selection Adjustment

The MB Series is available with standard, low, and high static options. These options will substitute a different blower drive sheave for each static range. In addition certain static ranges (see blower tables) may require the optional large fan motor. Please specify static range and motor horsepower when ordering. See model nomenclature.

### Sheave Adjustment

The MB Series is supplied with variable sheave drive on the fan motor to adjust for differing airflows at various ESP conditions. Select an airflow requirement on the left side of the table, then move horizontally to right under the required ESP. Contractor is responsible for balancing airflow, and maintaining static in duct as needed. Sheaves can be adjusted through the outlined static range at the selected airflows. Fully closed, the sheave will produce the highest static capability (higher rpm). To adjust sheave position: loosen belt tension and remove belt, loosen set screw on variable sheave (on fan motor) and open sheave to desired position. Re-tighten set screw and replace belt and set belt tension as below.

### Sheave and Pulley Alignment

Verify belt is straight; misalignment will cause premature belt failure. Adjust sheave if needed.

### Belt Tensioning

An overly loose belt will, upon motor start, produce a slippage 'squeel' and cause premature belt failure and or intermittent airflow. An overly-tight belt can cause premature belt, motor, or blower bearing failure.

Use the following steps to ensure proper belt tensioning:

1. Remove belt from motor sheave
2. Lift motor assembly
3. Loosen the  $\frac{5}{16}$ -inch hex nuts on the grommet motor adjustment bolts (two per bolt). To increase the belt tension loosen the top hex nut. To decrease the belt tension loosen the bottom hex nut.
4. Turn the bolts by hand to the desired position then tighten the  $\frac{5}{16}$ -inch hex nuts (two per bolt).
5. Lower the motor assembly
6. Install the belt
7. The belt should be tensioned with a tensioning gauge method such as the Browning Belt Tensioner to set proper belt tension (See next page).

### NOTES:

- **Motor position should not need adjustment.**
- **Motor sheave position is at mid position of each sheave. Thus the motor sheave is typically 2.5 turns open on a 5-turn sheave.**

### Special Note for AHRI Testing

The Units should be adjusted as follows for rated airflow:

- MB072 - 2400cfm/2.5 turns and 0.57 in wg ESP
- MB096 - 3200cfm/3.0 turns and 0.62 in wg ESP
- MB120 - 4000cfm/3.0 turns and 0.59 in wg ESP

## VFD Operation

### SINGLE ZONE VARIABLE AIR VOLUME (VAV)

Products with option “6” or “F” in the 14th digit of the model number come with a variable frequency drive (VFD) and are intended to be applied in single zone VAV applications. MB units use two CXM2 in a dual-board configuration. The VFD is controlled by board 2. The VFD receives a modulating 0-10VDC signal from the CXM2, and varies the output frequency directly proportionally to the input signal. With 60Hz frequency, a signal of 10VDC results in a 60Hz frequency to the motor and 100% fan speed. If the signal is 5VDC, the VFD output is 30Hz (50% fan speed).

### VFD BLOWER OPERATION

If the CXM2 is configured for VFD blower operation, the CXM2 controls an external VFD using a 0–10VDC control signal on AO1, and will default to the LAT control mode.

**NOTE: VFD output is 50% of last value during heating or cooling blower off delay times.**

The actual operating range for the VFD when the blower should be active is 2–10VDC associated to the operating speed of 0–100%. When the VFD should be off, the output should be set to 0VDC.

For each unit size, there is maximum and minimum operating speed at which the VFD can operate for any mode, defined in the **VFD Control Values** table.

The VFD blower may be operated in discrete speed or LAT control modes. If configured for discrete speed operation, the VFD speed is operated using one of the three set operating speeds for each unit size, defined the **VFD Control Values** table. If configured for LAT operation, the VFD speed is controlled by the CXM2 to achieve or maintain the selected target LAT value for the current operating mode.

### DISCRETE SPEED VFD OPERATION

When the CXM2 is configured for discrete-speed VFD operation, the VFD speed is set to the selected operating speed (A, B or C) for full-load heating or cooling. Full-load operation is defined as the second stage enabled in either heating or cooling. The possible discrete operating speeds for each unit size are defined in the **VFD Control Values** table.

When the CXM2 is configured for discrete-speed VFD operation, the VFD operating speed may be increased or decreased by 10%. The speed offset option defaults to normal (no offset). To increase the VFD operating speed by 10%, set the speed offset option to Increase. To decrease the VFD operating speed by 10%, set the speed offset option decrease.

When operating in first-stage heating or cooling, the VFD speed is set to the percentage multiplier of the selected full-load operating speed (A, B or C, plus or minus adjustment) listed for each unit size as defined in the **VFD Control Values** table.

### LAT CONTROL VFD OPERATION

When the CXM2 is configured for LAT control operation, the VFD speed is controlled by the CXM2 to maintain the selected target LAT for heating or cooling operation.

When a compressor demand is recognized, the VFD output is set to the most recent operating speed of the VFD in the current operating mode (heating or cooling). If there is no value stored from a previous heating or cooling cycle, the VFD speed is initially set to 75% or 8.0 VDC. After the VFD speed is initially set, the VFD control signal is not adjusted until after 90 seconds of compressor operation, then is periodically checked and adjusted every 10 seconds if needed to maintain the LAT.

## VFD Operation

If the control switches from the heating mode to cooling, or cooling to heating without deactivating the compressor, the VFD control voltage immediately switches to the last stored control voltage for the new operating mode, then is not adjusted for the first 90 seconds of operation in the new operating mode.

The VFD control voltage is increased or decreased incrementally based on the magnitude of the differential between the current LAT and the target LAT, using the following:

LAT differential  Actual – Target	VFD adjust (VDC)
$\Delta T \leq 1.0^{\circ}\text{F}$	0.0
$1.0 < \Delta T \leq 2.0^{\circ}\text{F}$	0.1
$2.0 < \Delta T \leq 3.0^{\circ}\text{F}$	0.2
$3.0 < \Delta T \leq 5.0^{\circ}\text{F}$	0.3
$\Delta T > 5.0^{\circ}\text{F}$	0.4

The VFD control voltage is increased or decreased based on both the operating mode and whether the current LAT is above or below the target LAT, using the following:

Operating mode	LAT differential (Actual – Target)	VFD voltage adjustment
Heat	Above	Increase
	Below	Decrease
Cool	Above	Decrease
	Below	Increase

NOTE: Blower speed is directly proportional to VFD output frequency and voltage

When the control stages from first to second stage operation, the output voltage signal is immediately increased by 25% of the current value, not to exceed the maximum speed (voltage) for the selected heat pump family and size. The blower speed is not adjusted further for 90 seconds after transition from first to second stage operation.

When making VFD speed adjustments for LAT control, the VFD speed should never go above the maximum speed (voltage) or below the minimum speed (voltage), for the selected heat pump family and size.

### CONTINUOUS FAN VFD OPERATION

When the CXM2 is configured for VFD blower operation, the continuous fan operating speed is a selectable value. The default continuous fan operating speeds (default fan speeds) are shown in the **VFD Control Values** table, along with the minimum and maximum operating speed values.

**NOTE: In VFD operation (Blower Type = 128), the VFD enable signal is triggered by the K1 relay. A01 output voltage for continuous fan operation will change to a percentage for the selected blower speed from the values presented in the VFD Control Values table or for full load airflow needs.**

Models:  
MB  
072-300

## VFD Operation

**Table 8: VFD Control Values**

Model	Minimum VFD Speed	Maximum VFD Speed	VFD Fixed Speed A	VFD Fixed Speed B	VFD Fixed Speed C	Part Load Multiplier	Default Fan Speed
MB072	3.7	10.0	7.4	6.2	9.0	71%	5.2
MB096	3.8	10.0	7.0	6.0	9.0	75%	5.0
MB120	4.2	10.0	8.0	7.0	9.0	70%	6.0
MB168	4.1	10.0	7.9	6.4	9.0	76%	5.4
MB192	4.4	10.0	8.0	7.0	9.0	73%	6.0
MB240	4.2	10.0	8.0	7.0	9.0	70%	6.0
MB300	5.0	10.0	8.0	8.0	9.5	71%	7.0

**Table 9: Operating Temperatures**

Model	Minimum Heat LAT	Maximum Heat LAT	Default Heat LAT	Minimum Cool LAT	Maximum Cool LAT	Default Cool LAT
MB072	85°	125°	105°	45°	65°	55°
MB096	85°	125°	105°	45°	65°	55°
MB120	85°	125°	105°	45°	65°	55°
MB168	85°	125°	105°	45°	65°	55°
MB192	85°	125°	105°	45°	65°	55°
MB240	85°	125°	105°	45°	65°	55°
MB300	85°	125°	105°	45°	65°	55°

### ADVANCED CONTROL ALGORITHM

**Option:** The CXM2 is a communicating controller which also features two-stage control of cooling and two-stage control of heating modes for exacting temperature and dehumidification purposes. This control system coupled with a multi-stage thermostat will better dehumidify room air by automatically running the heat pump’s fan at lower speed on the first stage of cooling thereby implementing low sensible-heat-ratio cooling.

When higher cooling performance is needed, the system will activate the second stage of cooling and automatically switch the fan to the higher fan speed setting.

When CXM2 is connected to the handheld service tool the installer/service technician can check and set CFM, toggle between discrete and LAT modes, select fixed fan speed, or LAT set point.

# Tensioning V-Belt Drives

## GENERAL RULES OF TENSIONING

1. Ideal tension is the lowest tension at which the belt will not slip under peak load conditions.
2. Check tension frequently during the first 24-48 hours of operation.
3. Over tensioning shortens belt and bearing life.
4. Keep belts free from foreign material which may cause slip.
5. Inspect the V-drive on a periodic basis. Tension when slipping. Never apply belt dressing as this will damage the belt and cause early failure.

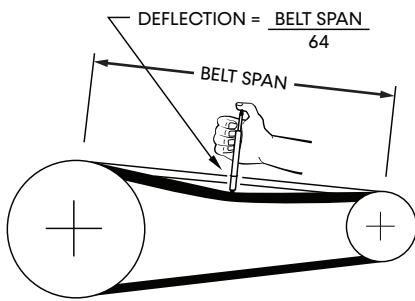

## TENSION MEASUREMENT PROCEDURE

6. Measure the belt span (see sketch).
7. Position bottom of the large "O" ring on the span scale at the measured belt span.
8. Set the small "O" ring on the deflection force scale to zero.
9. Place the tension checker squarely on one belt at the center of the belt span. Apply a force on the plunger and perpendicular to the belt span until the bottom of the large "O" ring is even with the top of the next belt or with the bottom of a straight edge laid across the sheaves.
10. Remove the tension checker and read the force applied from the bottom of the small "O" ring on the deflection force scale.
11. Compare the force you have applied with the values given in the **Belt Deflection** table. The force should be between the minimum and maximum shown. The maximum value is shown for "New Belt" and new belts should be tensioned at this value to allow for expected tension loss. Used belts should be maintained at the minimum value as indicated in the **Belt Deflection** table.

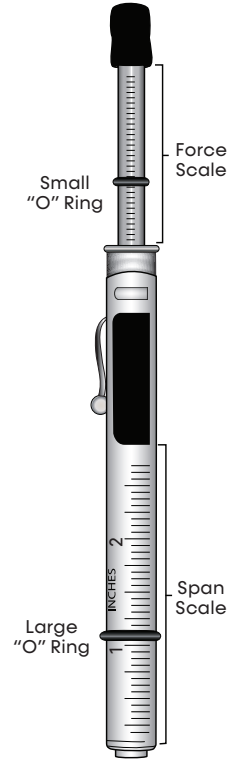

**NOTE: The ratio of deflection to belt span is 1:64.**

**Table 10: Belt Deflection**

Cross Section	Smallest Sheave Diameter Range	RPM Range	Belt Deflection Force			
			Super Gripbelts and Unnotched Gripbands		Gripnotch Belts and Notched Gripbands	
			Used Belt	New Belt	Used Belt	New Belt
A, AX	7.6 - 9.1	1000 - 2500	16.458	24.464	18.237	27.133
		2501 - 4000	12.454	18.682	15.123	22.240
	9.6 - 12.2	1000 - 2500	20.016	30.246	22.240	32.915
	12.7 - 17.8	2501 - 4000	16.902	25.354	19.126	28.467
		1000 - 2500	24.019	35.584	25.354	41.811
B, BX	8.6 - 10.7	1000 - 2500	-	-	22.685	33.805
		2501 - 4000	-	-	25.685	38.805
	11.2 - 14.2	860 - 2500	23.574	35.139	21.795	32.026
		2501 - 4000	20.016	29.802	18.682	27.578
	14.7 - 21.8	860 - 2500	28.022	41.811	36.029	46.704
		2501 - 4000	26.688	39.587	31.581	40.477

Models:  
MB  
072-300

## Blower Sheave Information

### Horizontal

Model Size	Drive Package	Sheave			Belt
		Motor	Blower	Bushing	
72	1,A	1VP34 X 7/8 B	BK67 X 1 B	-	V-BELT BX47
	2,B	1VP34 X 7/8 B	BK85 X 1 B	-	V-BELT BX50
	3,C	1VP44 X 7/8 B	BK67 X 1 B	-	V-BELT BX48
	4,D	1VP34 X 7/8 B	BK67 X 1 B	-	V-BELT BX47
	5,6,E,F	1VP44 X 7/8 B	BK67 X 1 B	-	V-BELT BX48
96	1,A	1VP40 X 7/8 B	BK67 X 1 B	-	V-BELT BX47
	2,B	1VP34 X 7/8 B	BK77 X 1 B	-	V-BELT BX48
	3,C	1VP44 X 7/8 B	BK62H	-	V-BELT BX47
	4,D	1VP40 X 7/8 B	BK67 X 1 B	-	V-BELT B49
	5,6,E,F	1VP44 X 7/8 B	BK62H	-	V-BELT B49
120	1,A	1VP44 X 7/8 B	BK67 X 1 B	-	V-BELT BX50
	2,B	1VP34 X 7/8 B	BK67 X 1 B	-	V-BELT B49
	3,C	1VP50 X 7/8 B	BK67 X 1 B	-	V-BELT BX51
	4,D	1VP44 X 1-1/8	BK67 X 1 B	-	V-BELT BX50
	5,6,E,F	1VP50 X 1-1/8 B	BK67 X 1 B	-	V-BELT BX51

### Vertical

Model Size	Drive Package	Sheave			Belt
		Motor	Blower	Bushing	
72	1,A	1VP34 X 7/8 B	BK67 X 1 B	-	V-BELT BX56
	2,B	1VP34 X 7/8 B	BK85 X 1 B	-	V-BELT BX59
	3,C	1VP44 X 7/8 B	BK67 X 1 B	-	V-BELT BX57
	4,D	1VP34 X 7/8 B	BK67 X 1 B	-	V-BELT BX56
	5,6,E,F	1VP44 X 7/8 B	BK67 X 1 B	-	V-BELT BX57
96	1,A	1VP40 X 7/8 B	BK67 X 1 B	-	V-BELT BX56
	2,B	1VP34 X 7/8 B	BK77 X 1 B	-	V-BELT BX57
	3,C	1VP44 X 7/8 B	BK62H	-	V-BELT BX56
	4,D	1VP40 X 7/8 B	BK67 X 1 B	-	V-BELT BX54
	5,6,E,F	1VP44 X 7/8 B	BK62H	-	V-BELT BX54
120	1,A	1VP44 X 7/8 B	BK67 X 1 B	-	V-BELT BX55
	2,B	1VP34 X 7/8 B	BK67 X 1 B	-	V-BELT BX54
	3,C	1VP50 X 7/8 B	BK67 X 1 B	-	V-BELT BX56
	4,D	1VP44 X 1-1/8	BK67 X 1 B	-	V-BELT BX55
	5,6,E,F	1VP50 X 1-1/8 B	BK67 X 1 B	-	V-BELT BX56
168	1,A	1VP44 X 7/8 B	BK80H	H x 1-3.16	V-BELT BX51
	2,B	1VP40 X 7/8 B	BK80H	H x 1-3.16	V-BELT BX51
	3,C	1VP50 X 7/8 B	BK80H	H x 1-3.16	V-BELT BX52
	4,D	1VP44 X 1-1/8	BK80H	H x 1-3.16	V-BELT BX51
	5,6,E,F	1VP50 X 1-1/8 B	BK80H	H x 1-3.16	V-BELT BX52
192	1,A	1VP44 X 7/8 B	BK77H	H x 1-3.16	V-BELT BX51
	2,B	1VP44 X 7/8 B	BK95H	H x 1-3.16	V-BELT BX54
	3,C	1VP50 X 7/8 B	BK70H	H x 1-3.16	V-BELT BX51
	4,D	1VP44 X 1-1/8	BK77H	H x 1-3.16	V-BELT BX51
	5,6,E,F	1VP50 X 1-1/8 B	BK70H	H x 1-3.16	V-BELT BX51
240	1,A	1VP60 X 1-1/8 B	BK90H	H x 1-3.16	V-BELT BX55
	2,B	1VP50 X 1-1/8 B	BK90H	H x 1-3.16	V-BELT BX54
	3,C	1VP60 X 1-1/8 B	BK80H	H x 1-3.16	V-BELT BX53
300	6,F	2VP60 X 1-3/8	2BK80H	H x 1-3.16	V-BELT BX52
	6,F	2VP62 X 1-3/8	2BK80H	H x 1-3.16	V-BELT BX53

# Blower Performance MB072

Models:  
MB  
072-300

SCFM	ESP (in.w.c.)	0.00	0.10	0.20	0.30	0.40	0.50	0.60	0.70	0.80	0.90	1.00	1.10	1.20	1.30	1.40	1.50
1,800	BHP			0.28	0.32	0.35	0.39	0.42	0.45	0.48	0.52	0.56	0.60	0.64	0.69	0.72	0.76
	Sheave/Mtr			B	B	B	A	A	A	A	A	A	C	C	C	C	C
	RPM			599	645	690	735	775	815	850	885	910	940	965	995	1015	1040
1,900	BHP			0.31	0.36	0.40	0.44	0.49	0.53	0.58	0.62	0.65	0.69	0.73	0.76	0.80	0.84
	Sheave/Mtr			B	B	A	A	A	A	A	A	C	C	C	C	C	C
	RPM			604	655	695	740	780	820	855	890	920	950	980	1005	1030	1055
2,000	BHP		0.31	0.34	0.39	0.45	0.50	0.54	0.59	0.63	0.67	0.72	0.75	0.79	0.82	0.86	0.90
	Sheave/Mtr		B	B	B	A	A	A	A	A	A	C	C	C	C	C	C
	RPM		568	615	660	705	750	785	825	860	895	930	960	990	1015	1040	1065
2,100	BHP	0.33	0.38	0.42	0.46	0.50	0.54	0.59	0.65	0.70	0.74	0.78	0.81	0.85	0.89	0.94	0.98
	Sheave/Mtr	B	B	B	A	A	A	A	A	A	A	C	C	C	C	C	C
	RPM	531	583	630	670	715	755	795	835	875	905	940	970	1000	1025	1055	1080
2,200	BHP	0.37	0.40	0.45	0.49	0.55	0.60	0.65	0.70	0.75	0.79	0.83	0.87	0.92	0.96	1.00	1.04
	Sheave/Mtr	B	B	B	A	A	A	A	A	A	C	C	C	C	C	E	E
	RPM	552	599	645	685	730	770	810	850	885	915	950	980	1010	1040	1065	1090
2,300	BHP	0.42	0.47	0.51	0.56	0.60	0.65	0.70	0.75	0.80	0.84	0.89	0.94	1.00	1.05	1.10	1.16
	Sheave/Mtr	B	B	B	A	A	A	A	A	A	C	C	C	E	E	E	E
	RPM	573	620	660	705	745	785	820	860	895	925	960	990	1020	1050	1075	1105
2,400	BHP	0.48	0.52	0.57	0.61	0.66	0.72	0.78	0.83	0.87	0.92	0.97	1.02	1.07	1.13	1.19	1.25
	Sheave/Mtr	B	B	A	A	A	A	A	A	A	C	C	E	E	E	E	E
	RPM	604	645	690	730	765	805	845	880	910	945	975	1010	1035	1065	1095	1125
2,500	BHP	0.52	0.57	0.61	0.66	0.72	0.78	0.83	0.89	0.94	1.00	1.03	1.08	1.14	1.20	1.25	1.31
	Sheave/Mtr	B	B	A	A	A	A	A	A	C	E	E	E	E	E	E	E
	RPM	620	660	700	740	780	815	850	885	920	950	985	1015	1045	1075	1100	1130
2,600	BHP	0.56	0.61	0.66	0.70	0.76	0.82	0.88	0.93	0.98	1.04	1.08	1.14	1.20	1.26	1.32	1.37
	Sheave/Mtr	B	A	A	A	A	A	A	A	C	E	E	E	E	E	E	E
	RPM	635	675	715	750	790	825	860	895	925	960	990	1020	1050	1080	1110	1135
2,700	BHP	0.61	0.66	0.71	0.76	0.82	0.87	0.93	0.98	1.04	1.10	1.15	1.21	1.27	1.33	1.39	1.45
	Sheave/Mtr	B	A	A	A	A	A	A	A	E	E	E	E	E	E	E	E
	RPM	655	695	730	770	805	840	875	905	940	970	1000	1030	1060	1090	1120	1145
2,800	BHP	0.66	0.72	0.77	0.83	0.88	0.93	0.99	1.05	1.11	1.16	1.22	1.30	1.37	1.44	1.51	1.57
	Sheave/Mtr	B	A	A	A	A	A	A	D	E	E	E	E	E	E	E	E
	RPM	670	710	750	785	815	850	885	915	950	980	1010	1040	1070	1100	1130	1155
2,900	BHP	0.71	0.77	0.82	0.87	0.93	0.98	1.04	1.10	1.16	1.22	1.30	1.36	1.43	1.50	1.57	1.63
	Sheave/Mtr	A	A	A	A	A	A	D	E	E	E	E	E	E	E	E	E
	RPM	685	725	765	795	830	860	895	925	955	985	1020	1045	1075	1105	1135	1160
3,000	BHP	0.79	0.84	0.90	0.95	1.01	1.07	1.13	1.19	1.25	1.31	1.38	1.46	1.52	1.59	1.66	
	Sheave/Mtr	A	A	A	A	A	D	D	E	E	E	E	E	E	E	E	
	RPM	710	745	780	815	850	885	915	945	975	1005	1035	1065	1090	1120	1150	

- Notes:
- A, 1 = Standard RPM/Standard Blower Motor
  - E, 5 = High RPM/Large Blower Motor
  - The maximum allowable altitude of installation for this product is 6,561 ft (2,000 m).

Models:  
MB  
072-300

# Blower Performance

## MB072 with VFD

SCFM	ESP (in.w.c.)	0.00	0.10	0.20	0.30	0.40	0.50	0.60	0.70	0.80	0.90	1.00	1.10	1.20	1.30	1.40	1.50
1,800	BHP			0.28	0.32	0.35	0.39	0.42	0.45	0.48	0.52	0.56	0.60	0.64	0.69	0.72	0.76
	Discrete Spd Setting			B	B	B	A	A	A	A	A	A	C	C	C	C	C
	RPM			599	645	690	735	775	815	850	885	910	940	965	995	1015	1040
1,900	BHP			0.31	0.36	0.40	0.44	0.49	0.53	0.58	0.62	0.65	0.69	0.73	0.76	0.80	0.84
	Discrete Spd Setting			B	B	A	A	A	A	A	A	C	C	C	C	C	C
	RPM			604	655	695	740	780	820	855	890	920	950	980	1005	1030	1055
2,000	BHP		0.31	0.34	0.39	0.45	0.50	0.54	0.59	0.63	0.67	0.72	0.75	0.79	0.82	0.86	0.90
	Discrete Spd Setting		B	B	B	A	A	A	A	A	A	C	C	C	C	C	C
	RPM		568	615	660	705	750	785	825	860	895	930	960	990	1015	1040	1065
2,100	BHP	0.33	0.38	0.42	0.46	0.50	0.54	0.59	0.65	0.70	0.74	0.78	0.81	0.85	0.89	0.94	0.98
	Discrete Spd Setting	B	B	B	A	A	A	A	A	A	A	C	C	C	C	C	C
	RPM	531	583	630	670	715	755	795	835	875	905	940	970	1000	1025	1055	1080
2,200	BHP	0.37	0.40	0.45	0.49	0.55	0.60	0.65	0.70	0.75	0.79	0.83	0.87	0.92	0.96	1.00	1.04
	Discrete Spd Setting	B	B	B	A	A	A	A	A	A	C	C	C	C	C	E	E
	RPM	552	599	645	685	730	770	810	850	885	915	950	980	1010	1040	1065	1090
2,300	BHP	0.42	0.47	0.51	0.56	0.60	0.65	0.70	0.75	0.80	0.84	0.89	0.94	1.00	1.05	1.10	1.16
	Discrete Spd Setting	B	B	B	A	A	A	A	A	A	C	C	C	C	C	C	C
	RPM	573	620	660	705	745	785	820	860	895	925	960	990	1020	1050	1075	1105
2,400	BHP	0.48	0.52	0.57	0.61	0.66	0.72	0.78	0.83	0.87	0.92	0.97	1.02	1.07	1.13	1.19	1.25
	Discrete Spd Setting	B	B	A	A	A	A	A	A	A	C	C	C	C	C	C	C
	RPM	604	645	690	730	765	805	845	880	910	945	975	1010	1035	1065	1095	1125
2,500	BHP	0.52	0.57	0.61	0.66	0.72	0.78	0.83	0.89	0.94	1.00	1.03	1.08	1.14	1.20	1.25	1.31
	Discrete Spd Setting	B	B	A	A	A	A	A	A	C	C	C	C	C	C	C	C
	RPM	620	660	700	740	780	815	850	885	920	950	985	1015	1045	1075	1100	1130
2,600	BHP	0.56	0.61	0.66	0.70	0.76	0.82	0.88	0.93	0.98	1.04	1.08	1.14	1.20	1.26	1.32	1.37
	Discrete Spd Setting	B	A	A	A	A	A	A	A	C	C	C	C	C	C	C	C
	RPM	635	675	715	750	790	825	860	895	925	960	990	1020	1050	1080	1110	1135
2,700	BHP	0.61	0.66	0.71	0.76	0.82	0.87	0.93	0.98	1.04	1.10	1.15	1.21	1.27	1.33	1.39	1.45
	Discrete Spd Setting	B	A	A	A	A	A	A	A	C	C	C	C	C	C	C	C
	RPM	655	695	730	770	805	840	875	905	940	970	1000	1030	1060	1090	1120	1145
2,800	BHP	0.66	0.72	0.77	0.83	0.88	0.93	0.99	1.05	1.11	1.16	1.22	1.30	1.37	1.44	1.51	1.57
	Discrete Spd Setting	B	A	A	A	A	A	A	A	C	C	C	C	C	C	C	C
	RPM	670	710	750	785	815	850	885	915	950	980	1010	1040	1070	1100	1130	1155
2,900	BHP	0.71	0.77	0.82	0.87	0.93	0.98	1.04	1.10	1.16	1.22	1.30	1.36	1.43	1.50	1.57	
	Discrete Spd Setting	A	A	A	A	A	A	A	C	C	C	C	C	C	C	C	
	RPM	685	725	765	795	830	860	895	925	955	985	1020	1045	1075	1105	1135	
3,000	BHP	0.79	0.84	0.90	0.95	1.01	1.07	1.13	1.19	1.25	1.31	1.38	1.46	1.52	1.59		
	Discrete Spd Setting	A	A	A	A	A	A	A	C	C	C	C	C	C	C		
	RPM	710	745	780	815	850	885	915	945	975	1005	1035	1065	1090	1120		

Notes:

- Motor Sheave set to 1-turn open from factory.
- Factory torque setting is A. Torque setting is field-adjustable to any torque setting listed in drive table through the Wireless Service Tool.
- The unit can control the blower through LAT control. Enable this setting in the field with the Wireless Service Tool.
- The maximum allowable altitude of installation for this product is 6,561 ft (2,000 m).

# Blower Performance MB096

Models:  
MB  
072-300

SCFM	ESP (in.w.c.)	0.00	0.10	0.20	0.30	0.40	0.50	0.60	0.70	0.80	0.90	1.00	1.10	1.20	1.30	1.40	1.50
2,400	BHP	0.45	0.50	0.54	0.59	0.63	0.69	0.74	0.80	0.85	0.90	0.94	0.99	1.04	1.10	1.16	1.22
	Sheave/Mtr	B	B	B	B	B	A	A	A	A	A	A	A	A	A	C	C
	RPM	578	625	665	705	745	785	820	860	895	925	960	990	1020	1050	1080	1110
2,500	BHP	0.50	0.55	0.59	0.64	0.69	0.75	0.81	0.88	0.92	0.97	1.01	1.06	1.12	1.17	1.23	1.29
	Sheave/Mtr	B	B	B	B	A	A	A	A	A	A	A	A	A	C	C	C
	RPM	599	645	685	725	765	800	835	875	905	940	970	1005	1035	1060	1090	1120
2,600	BHP	0.55	0.60	0.65	0.69	0.75	0.80	0.86	0.92	0.97	1.02	1.08	1.13	1.19	1.25	1.30	1.36
	Sheave/Mtr	B	B	B	B	A	A	A	A	A	A	A	A	A	C	C	C
	RPM	625	665	705	740	780	815	850	885	920	950	985	1015	1045	1075	1100	1130
2,700	BHP	0.60	0.65	0.70	0.75	0.80	0.86	0.91	0.97	1.02	1.08	1.14	1.20	1.26	1.32	1.38	1.44
	Sheave/Mtr	B	B	B	A	A	A	A	A	A	A	A	A	C	C	C	C
	RPM	645	685	725	760	795	830	865	900	930	960	995	1025	1055	1085	1115	1140
2,800	BHP	0.65	0.71	0.76	0.82	0.87	0.93	0.98	1.04	1.10	1.16	1.21	1.28	1.36	1.43	1.50	1.56
	Sheave/Mtr	B	B	B	A	A	A	A	A	A	A	A	A	C	C	C	C
	RPM	665	705	745	780	810	845	880	910	945	975	1005	1035	1065	1095	1125	1150
2,900	BHP	0.71	0.76	0.82	0.87	0.92	0.98	1.03	1.09	1.16	1.22	1.29	1.36	1.43	1.50	1.57	1.63
	Sheave/Mtr	B	B	A	A	A	A	A	A	A	A	A	A	C	C	C	C
	RPM	685	720	760	795	825	860	890	920	955	985	1015	1045	1075	1105	1135	1160
3,000	BHP	0.78	0.84	0.89	0.95	1.00	1.06	1.12	1.18	1.24	1.30	1.37	1.43	1.50	1.58	1.64	1.71
	Sheave/Mtr	B	B	A	A	A	A	A	A	A	A	A	C	C	C	C	C
	RPM	700	740	775	810	845	880	910	940	970	1000	1030	1055	1085	1115	1140	1170
3,100	BHP	0.85	0.91	0.96	1.02	1.08	1.14	1.22	1.29	1.36	1.44	1.50	1.57	1.63	1.70	1.76	1.82
	Sheave/Mtr	B	B	A	A	A	A	A	A	A	A	A	C	C	C	C	C
	RPM	720	755	790	825	860	890	925	955	985	1015	1040	1070	1095	1125	1150	1175
3,200	BHP	0.93	1.00	1.07	1.14	1.20	1.26	1.32	1.38	1.44	1.51	1.57	1.64	1.70	1.78	1.85	1.92
	Sheave/Mtr	B	A	A	A	A	A	A	A	A	A	C	C	C	C	C	C
	RPM	740	775	810	845	875	905	935	965	995	1025	1050	1080	1105	1135	1160	1185
3,300	BHP	1.01	1.08	1.14	1.21	1.28	1.33	1.39	1.45	1.51	1.58	1.64	1.72	1.78	1.84	1.93	2.00
	Sheave/Mtr	B	A	A	A	A	A	A	A	A	A	C	C	C	C	C	E
	RPM	755	790	820	855	890	915	945	975	1005	1035	1060	1090	1115	1140	1170	1195
3,400	BHP	1.08	1.15	1.22	1.29	1.35	1.41	1.47	1.53	1.59	1.68	1.75	1.83	1.90	1.96	2.02	2.08
	Sheave/Mtr	A	A	A	A	A	A	A	A	A	A	C	C	C	C	E	E
	RPM	765	800	835	870	900	930	960	990	1015	1045	1070	1100	1125	1150	1175	1200
3,500	BHP	1.16	1.23	1.29	1.36	1.42	1.48	1.54	1.60	1.66	1.73	1.79	1.85	1.92	2.01	2.09	2.17
	Sheave/Mtr	A	A	A	A	A	A	A	A	A	C	C	C	C	E	E	E
	RPM	780	815	845	880	910	940	970	1000	1025	1055	1080	1105	1130	1160	1185	1210

- Notes:
- A, 1 = Standard RPM/Standard Blower Motor
  - E, 5 = High RPM/Large Blower Motor
  - The maximum allowable altitude of installation for this product is 6,561 ft (2,000 m).

Table continued on next page.

Models:  
MB  
072-300

# Blower Performance

## MB096

Table continued from previous page.

SCFM	ESP (in.w.c.)	0.00	0.10	0.20	0.30	0.40	0.50	0.60	0.70	0.80	0.90	1.00	1.10	1.20	1.30	1.40	1.50
3,600	BHP	1.24	1.30	1.37	1.44	1.51	1.58	1.65	1.72	1.78	1.86	1.92	1.98	2.06	2.13	2.21	2.29
	Sheave/Mtr	A	A	A	A	A	A	A	A	A	C	C	C	E	E	E	E
	RPM	795	825	860	890	920	950	980	1010	1035	1065	1090	1115	1145	1165	1190	1215
3,700	BHP	1.34	1.40	1.46	1.53	1.61	1.68	1.75	1.82	1.90	1.97	2.06	2.13	2.21	2.28	2.36	2.44
	Sheave/Mtr	A	A	A	A	A	A	A	A	C	C	E	E	E	E	E	E
	RPM	820	850	880	910	940	970	1000	1025	1055	1080	1110	1135	1160	1180	1205	1230
3,800	BHP	1.43	1.49	1.56	1.63	1.70	1.78	1.86	1.94	2.02	2.12	2.20	2.28	2.34	2.42	2.50	2.58
	Sheave/Mtr	A	A	A	A	A	A	A	A	E	E	E	E	E	E	E	E
	RPM	840	870	900	930	960	990	1020	1045	1070	1100	1125	1150	1170	1195	1220	1245
3,900	BHP	1.58	1.64	1.71	1.78	1.85	1.93	2.01	2.09	2.19	2.27	2.35	2.41	2.49	2.57	2.65	
	Sheave/Mtr	A	A	A	A	A	A	D	D	E	E	E	E	E	E	E	
	RPM	865	890	920	950	980	1010	1035	1060	1090	1115	1140	1160	1185	1210	1235	
4,000	BHP	1.68	1.75	1.83	1.92	2.00	2.08	2.16	2.26	2.34	2.42	2.50	2.56	2.64	2.72	2.80	
	Sheave/Mtr	A	A	A	A	D	D	D	E	E	E	E	E	E	E	E	
	RPM	885	910	940	970	1000	1025	1050	1080	1105	1130	1155	1175	1200	1225	1250	

Notes:

- A, 1 = Standard RPM/Standard Blower Motor
- E, 5 = High RPM/Large Blower Motor
- The maximum allowable altitude of installation for this product is 6,561 ft (2,000 m).

# Blower Performance MB096 with VFD

Models:  
MB  
072-300

SCFM	ESP (in.w.c.)	0.00	0.10	0.20	0.30	0.40	0.50	0.60	0.70	0.80	0.90	1.00	1.10	1.20	1.30	1.40	1.50
2,400	BHP	0.45	0.50	0.54	0.59	0.63	0.69	0.74	0.80	0.85	0.90	0.94	0.99	1.04	1.10	1.16	1.22
	Discrete Spd Setting	B	B	B	B	B	A	A	A	A	A	A	A	A	A	C	C
	RPM	578	625	665	705	745	785	820	860	895	925	960	990	1020	1050	1080	1110
2,500	BHP	0.50	0.55	0.59	0.64	0.69	0.75	0.81	0.88	0.92	0.97	1.01	1.06	1.12	1.17	1.23	1.29
	Discrete Spd Setting	B	B	B	B	A	A	A	A	A	A	A	A	A	C	C	C
	RPM	599	645	685	725	765	800	835	875	905	940	970	1005	1035	1060	1090	1120
2,600	BHP	0.55	0.60	0.65	0.69	0.75	0.80	0.86	0.92	0.97	1.02	1.08	1.13	1.19	1.25	1.30	1.36
	Discrete Spd Setting	B	B	B	B	A	A	A	A	A	A	A	A	A	C	C	C
	RPM	625	665	705	740	780	815	850	885	920	950	985	1015	1045	1075	1100	1130
2,700	BHP	0.60	0.65	0.70	0.75	0.80	0.86	0.91	0.97	1.02	1.08	1.14	1.20	1.26	1.32	1.38	1.44
	Discrete Spd Setting	B	B	B	A	A	A	A	A	A	A	A	A	C	C	C	C
	RPM	645	685	725	760	795	830	865	900	930	960	995	1025	1055	1085	1115	1140
2,800	BHP	0.65	0.71	0.76	0.82	0.87	0.93	0.98	1.04	1.10	1.16	1.21	1.28	1.36	1.43	1.50	1.56
	Discrete Spd Setting	B	B	B	A	A	A	A	A	A	A	A	A	C	C	C	C
	RPM	665	705	745	780	810	845	880	910	945	975	1005	1035	1065	1095	1125	1150
2,900	BHP	0.71	0.76	0.82	0.87	0.92	0.98	1.03	1.09	1.16	1.22	1.29	1.36	1.43	1.50	1.57	1.63
	Discrete Spd Setting	B	B	A	A	A	A	A	A	A	A	A	A	C	C	C	C
	RPM	685	720	760	795	825	860	890	920	955	985	1015	1045	1075	1105	1135	1160
3,000	BHP	0.78	0.84	0.89	0.95	1.00	1.06	1.12	1.18	1.24	1.30	1.37	1.43	1.50	1.58	1.64	1.71
	Discrete Spd Setting	B	B	A	A	A	A	A	A	A	A	A	C	C	C	C	C
	RPM	700	740	775	810	845	880	910	940	970	1000	1030	1055	1085	1115	1140	1170
3,100	BHP	0.85	0.91	0.96	1.02	1.08	1.14	1.22	1.29	1.36	1.44	1.50	1.57	1.63	1.70	1.76	1.82
	Discrete Spd Setting	B	B	A	A	A	A	A	A	A	A	A	C	C	C	C	C
	RPM	720	755	790	825	860	890	925	955	985	1015	1040	1070	1095	1125	1150	1175
3,200	BHP	0.93	1.00	1.07	1.14	1.20	1.26	1.32	1.38	1.44	1.51	1.57	1.64	1.70	1.78	1.85	1.92
	Discrete Spd Setting	B	A	A	A	A	A	A	A	A	A	C	C	C	C	C	C
	RPM	740	775	810	845	875	905	935	965	995	1025	1050	1080	1105	1135	1160	1185
3,300	BHP	1.01	1.08	1.14	1.21	1.28	1.33	1.39	1.45	1.51	1.58	1.64	1.72	1.78	1.84	1.93	2.00
	Discrete Spd Setting	B	A	A	A	A	A	A	A	A	A	C	C	C	C	C	C
	RPM	755	790	820	855	890	915	945	975	1005	1035	1060	1090	1115	1140	1170	1195
3,400	BHP	1.08	1.15	1.22	1.29	1.35	1.41	1.47	1.53	1.59	1.68	1.75	1.83	1.90	1.96	2.02	2.08
	Discrete Spd Setting	A	A	A	A	A	A	A	A	A	A	C	C	C	C	C	C
	RPM	765	800	835	870	900	930	960	990	1015	1045	1070	1100	1125	1150	1175	1200

Notes:

- Motor Sheave set to 1-turn open from factory.
- Factory torque setting is A. Torque setting is field-adjustable to any torque setting listed in drive table through the Wireless Service Tool.
- The unit can control the blower through LAT control. Enable this setting in the field with the Wireless Service Tool.
- The maximum allowable altitude of installation for this product is 6,561 ft (2,000 m).

Table continued on next page.

Models:  
MB  
072-300

## Blower Performance MB096 with VFD

Table continued from previous page.

SCFM	ESP (in.w.c.)	0.00	0.10	0.20	0.30	0.40	0.50	0.60	0.70	0.80	0.90	1.00	1.10	1.20	1.30	1.40	1.50
3,500	BHP	1.16	1.23	1.29	1.36	1.42	1.48	1.54	1.60	1.66	1.73	1.79	1.85	1.92	2.01	2.09	2.17
	Discrete Spd Setting	A	A	A	A	A	A	A	A	A	C	C	C	C	C	C	C
	RPM	780	815	845	880	910	940	970	1000	1025	1055	1080	1105	1130	1160	1185	1210
3,600	BHP	1.24	1.30	1.37	1.44	1.51	1.58	1.65	1.72	1.78	1.86	1.92	1.98	2.06	2.13	2.21	2.29
	Discrete Spd Setting	A	A	A	A	A	A	A	A	A	C	C	C	C	C	C	C
	RPM	795	825	860	890	920	950	980	1010	1035	1065	1090	1115	1145	1165	1190	1215
3,700	BHP	1.34	1.40	1.46	1.53	1.61	1.68	1.75	1.82	1.90	1.97	2.06	2.13	2.21	2.28	2.36	2.44
	Discrete Spd Setting	A	A	A	A	A	A	A	A	C	C	C	C	C	C	C	C
	RPM	820	850	880	910	940	970	1000	1025	1055	1080	1110	1135	1160	1180	1205	1230
3,800	BHP	1.43	1.49	1.56	1.63	1.70	1.78	1.86	1.94	2.02	2.12	2.20	2.28	2.34	2.42	2.50	2.58
	Discrete Spd Setting	A	A	A	A	A	A	A	A	C	C	C	C	C	C	C	C
	RPM	840	870	900	930	960	990	1020	1045	1070	1100	1125	1150	1170	1195	1220	1245
3,900	BHP	1.58	1.64	1.71	1.78	1.85	1.93	2.01	2.09	2.19	2.27	2.35	2.41	2.49	2.57	2.65	
	Discrete Spd Setting	A	A	A	A	A	A	A	A	C	C	C	C	C	C	C	
	RPM	865	890	920	950	980	1010	1035	1060	1090	1115	1140	1160	1185	1210	1235	
4,000	BHP	1.68	1.75	1.83	1.92	2.00	2.08	2.16	2.26	2.34	2.42	2.50	2.56	2.64	2.72	2.80	
	Discrete Spd Setting	A	A	A	A	A	A	A	C	C	C	C	C	C	C	C	
	RPM	885	910	940	970	1000	1025	1050	1080	1105	1130	1155	1175	1200	1225	1250	

Notes:

- Motor Sheave set to 1-turn open from factory.
- Factory torque setting is A. Torque setting is field-adjustable to any torque setting listed in drive table through the Wireless Service Tool.
- The unit can control the blower through LAT control. Enable this setting in the field with the Wireless Service Tool.
- The maximum allowable altitude of installation for this product is 6,561 ft (2,000 m).

# Blower Performance MB120

Models:  
MB  
072-300

SCFM	ESP (in.w.c.)	0.00	0.10	0.20	0.30	0.40	0.50	0.60	0.70	0.80	0.90	1.00	1.10	1.20	1.30	1.40	1.50
3,000	BHP	0.75	0.81	0.86	0.91	0.97	1.03	1.09	1.15	1.21	1.27	1.34	1.41	1.47	1.54	1.61	1.67
	Sheave/Mtr	B	B	B	B	B	B	A	A	A	A	A	A	A	A	A	A
	RPM	680	720	755	790	825	860	895	925	955	985	1015	1045	1070	1100	1130	1155
3,100	BHP	0.82	0.88	0.94	0.99	1.04	1.10	1.17	1.26	1.33	1.40	1.46	1.53	1.59	1.66	1.72	1.80
	Sheave/Mtr	B	B	B	B	B	A	A	A	A	A	A	A	A	A	A	C
	RPM	700	735	775	805	840	875	905	940	970	1000	1025	1055	1080	1110	1135	1165
3,200	BHP	0.90	0.96	1.03	1.10	1.17	1.23	1.29	1.35	1.41	1.47	1.55	1.61	1.68	1.74	1.81	1.89
	Sheave/Mtr	B	B	B	B	B	A	A	A	A	A	A	A	A	A	A	C
	RPM	720	755	790	825	860	890	920	950	980	1010	1040	1065	1095	1120	1145	1175
3,300	BHP	0.98	1.04	1.11	1.18	1.25	1.31	1.37	1.43	1.49	1.55	1.62	1.68	1.75	1.81	1.88	1.95
	Sheave/Mtr	B	B	B	B	A	A	A	A	A	A	A	A	A	A	A	C
	RPM	740	770	805	840	875	905	935	965	995	1020	1050	1075	1105	1130	1155	1180
3,400	BHP	1.06	1.13	1.19	1.26	1.33	1.38	1.44	1.50	1.56	1.65	1.72	1.80	1.87	1.94	2.00	2.06
	Sheave/Mtr	B	B	B	B	A	A	A	A	A	A	A	A	A	A	C	C
	RPM	755	790	820	855	890	915	945	975	1005	1035	1060	1090	1115	1140	1165	1190
3,500	BHP	1.14	1.21	1.27	1.34	1.40	1.46	1.52	1.58	1.65	1.71	1.77	1.84	1.90	1.98	2.06	2.14
	Sheave/Mtr	B	B	B	A	A	A	A	A	A	A	A	A	A	A	C	C
	RPM	770	805	835	870	900	930	960	990	1020	1045	1070	1100	1125	1150	1175	1200
3,600	BHP	1.23	1.29	1.36	1.42	1.50	1.57	1.64	1.71	1.77	1.84	1.90	1.96	2.05	2.13	2.21	2.27
	Sheave/Mtr	B	B	B	A	A	A	A	A	A	A	A	A	A	C	C	C
	RPM	790	820	855	885	915	945	975	1005	1030	1060	1085	1110	1140	1165	1190	1210
3,700	BHP	1.32	1.38	1.44	1.51	1.58	1.65	1.73	1.81	1.88	1.96	2.03	2.10	2.18	2.26	2.34	2.42
	Sheave/Mtr	B	B	A	A	A	A	A	A	A	A	A	A	A	C	C	C
	RPM	810	840	870	900	930	960	990	1020	1045	1075	1100	1125	1150	1175	1200	1225
3,800	BHP	1.41	1.47	1.54	1.61	1.68	1.75	1.82	1.91	1.99	2.07	2.17	2.25	2.31	2.39	2.47	2.55
	Sheave/Mtr	B	B	A	A	A	A	A	A	A	A	A	A	A	C	C	C
	RPM	830	860	890	920	950	980	1005	1035	1060	1085	1115	1140	1160	1185	1210	1235
3,900	BHP	1.54	1.60	1.67	1.74	1.82	1.89	1.96	2.04	2.14	2.22	2.30	2.38	2.46	2.52	2.60	2.68
	Sheave/Mtr	B	A	A	A	A	A	A	A	A	A	A	A	C	C	C	C
	RPM	850	875	905	935	965	995	1020	1045	1075	1100	1125	1150	1175	1195	1220	1245
4,000	BHP	1.63	1.71	1.78	1.86	1.94	2.03	2.11	2.19	2.27	2.37	2.45	2.51	2.59	2.67	2.75	2.85
	Sheave/Mtr	A	A	A	A	A	A	A	A	A	A	A	A	C	C	C	C
	RPM	865	895	920	950	980	1010	1035	1060	1085	1115	1140	1160	1185	1210	1235	1260
4,100	BHP	1.73	1.81	1.90	1.97	2.05	2.12	2.20	2.27	2.34	2.42	2.52	2.62	2.70	2.80	2.90	
	Sheave/Mtr	A	A	A	A	A	A	A	A	A	A	A	C	C	C	C	
	RPM	885	915	945	970	1000	1025	1055	1080	1105	1130	1155	1180	1200	1225	1250	
4,200	BHP	1.87	1.94	2.02	2.08	2.16	2.24	2.32	2.40	2.48	2.58	2.68	2.76	2.86	2.96		
	Sheave/Mtr	A	A	A	A	A	A	A	A	A	A	C	C	C	C		
	RPM	905	935	965	990	1020	1045	1070	1095	1120	1145	1170	1190	1215	1240		

- Notes:
- A, 1 = Standard RPM/Standard Blower Motor
  - E, 5 = High RPM/Large Blower Motor
  - The maximum allowable altitude of installation for this product is 6,561 ft (2,000 m).

Table continued on next page.

Models:  
MB  
072-300

# Blower Performance

## MB120

Table continued from previous page.

SCFM	ESP (in.w.c.)	0.00	0.10	0.20	0.30	0.40	0.50	0.60	0.70	0.80	0.90	1.00	1.10	1.20	1.30	1.40	1.50
4,300	BHP	2.00	2.07	2.16	2.23	2.31	2.41	2.49	2.57	2.66	2.74	2.84	2.94	3.02	3.15		
	Sheave/Mtr	A	A	A	A	A	A	A	A	A	C	C	C	E	E		
	RPM	930	955	985	1010	1035	1065	1090	1115	1140	1160	1185	1210	1230	1255		
4,400	BHP	2.14	2.22	2.32	2.40	2.48	2.56	2.65	2.74	2.82	2.92	3.00	3.10	3.18			
	Sheave/Mtr	A	A	A	A	A	A	A	A	A	C	E	E	E			
	RPM	950	975	1005	1030	1055	1080	1110	1135	1155	1180	1200	1225	1245			
4,500	BHP	2.30	2.38	2.46	2.54	2.62	2.72	2.80	2.88	3.00	3.08	3.16	3.26				
	Sheave/Mtr	A	A	A	A	A	A	A	A	D	E	E	E				
	RPM	970	995	1020	1045	1070	1100	1125	1145	1170	1195	1215	1240				
4,600	BHP	2.39	2.45	2.54	2.63	2.72	2.83	2.92	3.00	3.10	3.18	3.28	3.38				
	Sheave/Mtr	A	A	A	A	A	A	A	D	D	E	E	E				
	RPM	980	1000	1025	1050	1075	1105	1130	1150	1175	1195	1220	1245				
4,700	BHP	2.46	2.52	2.62	2.72	2.82	2.92	3.02	3.12	3.22	3.32	3.40	3.50				
	Sheave/Mtr	A	A	A	A	A	A	D	D	E	E	E	E				
	RPM	985	1005	1030	1055	1080	1105	1130	1155	1180	1205	1225	1250				
4,800	BHP	2.57	2.64	2.74	2.84	2.94	3.04	3.14	3.24	3.32	3.42	3.52	3.60				
	Sheave/Mtr	A	A	A	A	A	D	D	D	E	E	E	E				
	RPM	990	1010	1035	1060	1085	1110	1135	1160	1180	1205	1230	1250				
4,900	BHP	2.68	2.78	2.88	3.00	3.06	3.16	3.26	3.36	3.44	3.54	3.64	3.75				
	Sheave/Mtr	A	A	A	D	D	D	D	E	E	E	E	E				
	RPM	995	1020	1045	1070	1090	1115	1140	1165	1185	1210	1235	1255				
5,000	BHP	2.82	2.92	3.00	3.10	3.20	3.28	3.38	3.48	3.56	3.66	3.74					
	Sheave/Mtr	A	A	D	D	D	D	D	E	E	E	E					
	RPM	1005	1030	1050	1075	1100	1120	1145	1170	1190	1215	1235					

Notes:

- A, 1 = Standard RPM/Standard Blower Motor
- E, 5 = High RPM/Large Blower Motor
- The maximum allowable altitude of installation for this product is 6,561 ft (2,000 m).

# Blower Performance MB120 with VFD

Models:  
MB  
072-300

SCFM	ESP (in.w.c.)	0.00	0.10	0.20	0.30	0.40	0.50	0.60	0.70	0.80	0.90	1.00	1.10	1.20	1.30	1.40	1.50
3,000	BHP	0.75	0.81	0.86	0.91	0.97	1.03	1.09	1.15	1.21	1.27	1.34	1.41	1.47	1.54	1.61	1.67
	Discrete Spd Setting	B	B	B	B	B	B	A	A	A	A	A	A	A	A	A	A
	RPM	680	720	755	790	825	860	895	925	955	985	1015	1045	1070	1100	1130	1155
3,100	BHP	0.82	0.88	0.94	0.99	1.04	1.10	1.17	1.26	1.33	1.40	1.46	1.53	1.59	1.66	1.72	1.80
	Discrete Spd Setting	B	B	B	B	B	A	A	A	A	A	A	A	A	A	A	C
	RPM	700	735	775	805	840	875	905	940	970	1000	1025	1055	1080	1110	1135	1165
3,200	BHP	0.90	0.96	1.03	1.10	1.17	1.23	1.29	1.35	1.41	1.47	1.55	1.61	1.68	1.74	1.81	1.89
	Discrete Spd Setting	B	B	B	B	B	A	A	A	A	A	A	A	A	A	A	C
	RPM	720	755	790	825	860	890	920	950	980	1010	1040	1065	1095	1120	1145	1175
3,300	BHP	0.98	1.04	1.11	1.18	1.25	1.31	1.37	1.43	1.49	1.55	1.62	1.68	1.75	1.81	1.88	1.95
	Discrete Spd Setting	B	B	B	B	A	A	A	A	A	A	A	A	A	A	A	C
	RPM	740	770	805	840	875	905	935	965	995	1020	1050	1075	1105	1130	1155	1180
3,400	BHP	1.06	1.13	1.19	1.26	1.33	1.38	1.44	1.50	1.56	1.65	1.72	1.80	1.87	1.94	2.00	2.06
	Discrete Spd Setting	B	B	B	B	A	A	A	A	A	A	A	A	A	A	C	C
	RPM	755	790	820	855	890	915	945	975	1005	1035	1060	1090	1115	1140	1165	1190
3,500	BHP	1.14	1.21	1.27	1.34	1.40	1.46	1.52	1.58	1.65	1.71	1.77	1.84	1.90	1.98	2.06	2.14
	Discrete Spd Setting	B	B	B	A	A	A	A	A	A	A	A	A	A	A	C	C
	RPM	770	805	835	870	900	930	960	990	1020	1045	1070	1100	1125	1150	1175	1200
3,600	BHP	1.23	1.29	1.36	1.42	1.50	1.57	1.64	1.71	1.77	1.84	1.90	1.96	2.05	2.13	2.21	2.27
	Discrete Spd Setting	B	B	B	A	A	A	A	A	A	A	A	A	A	C	C	C
	RPM	790	820	855	885	915	945	975	1005	1030	1060	1085	1110	1140	1165	1190	1210
3,700	BHP	1.32	1.38	1.44	1.51	1.58	1.65	1.73	1.81	1.88	1.96	2.03	2.10	2.18	2.26	2.34	2.42
	Discrete Spd Setting	B	B	A	A	A	A	A	A	A	A	A	A	A	C	C	C
	RPM	810	840	870	900	930	960	990	1020	1045	1075	1100	1125	1150	1175	1200	1225
3,800	BHP	1.41	1.47	1.54	1.61	1.68	1.75	1.82	1.91	1.99	2.07	2.17	2.25	2.31	2.39	2.47	2.55
	Discrete Spd Setting	B	B	A	A	A	A	A	A	A	A	A	A	A	C	C	C
	RPM	830	860	890	920	950	980	1005	1035	1060	1085	1115	1140	1160	1185	1210	1235
3,900	BHP	1.54	1.60	1.67	1.74	1.82	1.89	1.96	2.04	2.14	2.22	2.30	2.38	2.46	2.52	2.60	2.68
	Discrete Spd Setting	B	A	A	A	A	A	A	A	A	A	A	A	C	C	C	C
	RPM	850	875	905	935	965	995	1020	1045	1075	1100	1125	1150	1175	1195	1220	1245
4,000	BHP	1.63	1.71	1.78	1.86	1.94	2.03	2.11	2.19	2.27	2.37	2.45	2.51	2.59	2.67	2.75	2.85
	Discrete Spd Setting	A	A	A	A	A	A	A	A	A	A	A	A	C	C	C	C
	RPM	865	895	920	950	980	1010	1035	1060	1085	1115	1140	1160	1185	1210	1235	1260
4,100	BHP	1.73	1.81	1.90	1.97	2.05	2.12	2.20	2.27	2.34	2.42	2.52	2.62	2.70	2.80	2.90	
	Discrete Spd Setting	A	A	A	A	A	A	A	A	A	A	A	C	C	C	C	
	RPM	885	915	945	970	1000	1025	1055	1080	1105	1130	1155	1180	1200	1225	1250	
4,200	BHP	1.87	1.94	2.02	2.08	2.16	2.24	2.32	2.40	2.48	2.58	2.68	2.76	2.86	2.96		
	Discrete Spd Setting	A	A	A	A	A	A	A	A	A	A	C	C	C	C		
	RPM	905	935	965	990	1020	1045	1070	1095	1120	1145	1170	1190	1215	1240		
4,300	BHP	2.00	2.07	2.16	2.23	2.31	2.41	2.49	2.57	2.66	2.74	2.84	2.94	3.02	3.15		
	Discrete Spd Setting	A	A	A	A	A	A	A	A	A	C	C	C	E	E		
	RPM	930	955	985	1010	1035	1065	1090	1115	1140	1160	1185	1210	1230	1255		

Notes:

- Motor Sheave set to 1-turn open from factory.
- Factory torque setting is A. Torque setting is field-adjustable to any torque setting listed in drive table through the Wireless Service Tool.
- The unit can control the blower through LAT control. Enable this setting in the field with the Wireless Service Tool.
- The maximum allowable altitude of installation for this product is 6,561 ft (2,000 m).

Table continued on next page.

Models:  
MB  
072-300

# Blower Performance MB120 with VFD

Table continued from previous page.

SCFM	ESP (in.w.c.)	0.00	0.10	0.20	0.30	0.40	0.50	0.60	0.70	0.80	0.90	1.00	1.10	1.20	1.30	1.40	1.50	
4,400	BHP	2.14	2.22	2.32	2.40	2.48	2.56	2.65	2.74	2.82	2.92	3.00	3.10	3.18				
	Discrete Spd Setting	A	A	A	A	A	A	A	A	A	C	C	C	C				
	RPM	950	975	1005	1030	1055	1080	1110	1135	1155	1180	1200	1225	1245				
4,500	BHP	2.30	2.38	2.46	2.54	2.62	2.72	2.80	2.88	3.00	3.08	3.16	3.26					
	Discrete Spd Setting	A	A	A	A	A	A	A	A	A	C	C	C					
	RPM	970	995	1020	1045	1070	1100	1125	1145	1170	1195	1215	1240					
4,600	BHP	2.39	2.45	2.54	2.63	2.72	2.83	2.92	3.00	3.10	3.18	3.28	3.38					
	Discrete Spd Setting	A	A	A	A	A	A	A	A	A	C	C	C					
	RPM	980	1000	1025	1050	1075	1105	1130	1150	1175	1195	1220	1245					
4,700	BHP	2.46	2.52	2.62	2.72	2.82	2.92	3.02	3.12	3.22	3.32	3.40	3.50					
	Discrete Spd Setting	A	A	A	A	A	A	A	A	C	C	C	C					
	RPM	985	1005	1030	1055	1080	1105	1130	1155	1180	1205	1225	1250					
4,800	BHP	2.57	2.64	2.74	2.84	2.94	3.04	3.14	3.24	3.32	3.42	3.52	3.60					
	Discrete Spd Setting	A	A	A	A	A	A	A	A	C	C	C	C					
	RPM	990	1010	1035	1060	1085	1110	1135	1160	1180	1205	1230	1250					
4,900	BHP	2.68	2.78	2.88	3.00	3.06	3.16	3.26	3.36	3.44	3.54	3.64	3.75					
	Discrete Spd Setting	A	A	A	A	A	A	A	C	C	C	C	C					
	RPM	995	1020	1045	1070	1090	1115	1140	1165	1185	1210	1235	1255					
5,000	BHP	2.82	2.92	3.00	3.10	3.20	3.28	3.38	3.48	3.56	3.66	3.74						
	Discrete Spd Setting	A	A	A	A	A	A	A	C	C	C	C						
	RPM	1005	1030	1050	1075	1100	1120	1145	1170	1190	1215	1235						

Notes:

- Motor Sheave set to 1-turn open from factory.
- Factory torque setting is A. Torque setting is field-adjustable to any torque setting listed in drive table through the Wireless Service Tool.
- The unit can control the blower through LAT control. Enable this setting in the field with the Wireless Service Tool.
- The maximum allowable altitude of installation for this product is 6,561 ft (2,000 m).

# Blower Performance MB168

Models:  
MB  
072-300

SCFM	ESP (in.w.c.)	0.00	0.10	0.20	0.30	0.40	0.50	0.60	0.70	0.80	0.90	1.00	1.10	1.20	1.30	1.40	1.50
4,200	BHP			0.69	0.78	0.86	0.95	1.02	1.11	1.21	1.32	1.41	1.50	1.57	1.64	1.72	1.80
	Sheave/Mtr			B	B	B	B	A	A	A	A	A	A	A	C	C	C
	RPM			547	594	640	685	725	765	805	845	880	915	945	975	1005	1030
4,400	BHP			0.75	0.83	0.92	1.01	1.11	1.21	1.31	1.41	1.51	1.60	1.68	1.76	1.85	1.94
	Sheave/Mtr			B	B	B	B	A	A	A	A	A	A	A	C	C	C
	RPM			563	609	655	695	735	775	815	855	890	925	955	985	1015	1045
4,600	BHP		0.75	0.85	0.95	1.03	1.11	1.19	1.30	1.40	1.50	1.60	1.70	1.78	1.89	2.00	2.10
	Sheave/Mtr		B	B	B	B	B	A	A	A	A	A	A	C	C	C	C
	RPM		526	573	625	665	705	745	785	825	860	895	930	960	995	1025	1050
4,800	BHP		0.83	0.94	1.03	1.12	1.20	1.30	1.40	1.53	1.63	1.73	1.82	1.92	2.00	2.12	2.22
	Sheave/Mtr		B	B	B	B	A	A	A	A	A	A	A	C	C	C	C
	RPM		542	594	640	680	720	760	795	835	870	905	935	970	1000	1030	1055
5,000	BHP		0.93	1.02	1.11	1.20	1.31	1.41	1.52	1.64	1.76	1.85	1.95	2.03	2.12	2.24	2.36
	Sheave/Mtr		B	B	B	B	A	A	A	A	A	A	A	C	C	C	C
	RPM		563	609	650	690	735	770	805	840	880	910	945	975	1005	1035	1065
5,200	BHP	0.93	1.02	1.10	1.20	1.29	1.39	1.50	1.61	1.72	1.83	1.94	2.06	2.15	2.26	2.38	2.50
	Sheave/Mtr	B	B	B	B	B	A	A	A	A	A	A	A	C	C	C	C
	RPM	542	583	625	665	705	745	780	815	850	885	920	955	985	1015	1045	1075
5,400	BHP	1.03	1.10	1.19	1.29	1.39	1.50	1.59	1.70	1.80	1.92	2.03	2.16	2.26	2.38	2.50	2.62
	Sheave/Mtr	B	B	B	B	B	A	A	A	A	A	A	C	C	C	C	C
	RPM	563	599	640	680	720	760	790	825	860	895	925	960	990	1020	1050	1080
5,600	BHP	1.12	1.19	1.28	1.39	1.50	1.61	1.72	1.84	1.93	2.06	2.17	2.29	2.40	2.54	2.69	2.83
	Sheave/Mtr	B	B	B	B	A	A	A	A	A	A	A	C	C	C	C	C
	RPM	583	620	655	695	735	770	805	840	870	905	935	970	1000	1030	1060	1090
5,800	BHP	1.17	1.28	1.39	1.49	1.60	1.70	1.81	1.90	2.02	2.14	2.28	2.40	2.52	2.67	2.81	2.96
	Sheave/Mtr	B	B	B	B	A	A	A	A	A	A	A	C	C	C	C	C
	RPM	588	630	670	710	750	780	815	845	880	910	945	975	1005	1035	1065	1095
6,000	BHP	1.25	1.40	1.51	1.61	1.73	1.84	1.94	2.05	2.18	2.30	2.42	2.54	2.67	2.79	2.94	3.08
	Sheave/Mtr	B	B	B	A	A	A	A	A	A	A	A	C	C	C	C	E
	RPM	604	645	685	720	760	795	825	860	895	925	955	985	1015	1040	1070	1100
6,200	BHP	1.40	1.51	1.62	1.75	1.86	1.98	2.09	2.20	2.34	2.49	2.63	2.78	2.92	3.06	3.18	
	Sheave/Mtr	B	B	B	A	A	A	A	A	A	A	C	C	C	E	E	
	RPM	625	660	695	735	770	805	840	875	905	935	965	995	1025	1055	1080	
6,400	BHP	1.55	1.68	1.79	1.90	2.04	2.18	2.32	2.44	2.56	2.68	2.80	2.92	3.07	3.19	3.33	
	Sheave/Mtr	B	B	B	A	A	A	A	A	A	A	C	C	E	E	E	
	RPM	640	680	715	750	785	820	855	885	915	945	975	1005	1035	1060	1090	
6,600	BHP	1.73	1.84	1.94	2.06	2.20	2.34	2.46	2.58	2.70	2.82	2.94	3.07	3.19	3.34	3.46	
	Sheave/Mtr	B	B	A	A	A	A	A	A	A	A	C	E	E	E	E	
	RPM	665	700	730	765	800	835	865	895	925	955	985	1015	1040	1070	1095	
6,800	BHP	1.87	1.98	2.08	2.20	2.34	2.48	2.62	2.74	2.86	2.96	3.08	3.24	3.38	3.55		
	Sheave/Mtr	B	B	A	A	A	A	A	A	A	C	E	E	E	E		
	RPM	685	715	745	775	810	845	880	910	940	965	995	1025	1050	1080		
7,000	BHP	2.03	2.13	2.22	2.36	2.50	2.62	2.76	2.88	3.00	3.12	3.22	3.37	3.49	3.61		
	Sheave/Mtr	B	A	A	A	A	A	A	A	D	E	E	E	E	E		
	RPM	705	730	755	790	825	855	890	920	950	980	1005	1035	1060	1085		

Notes:  
 • A, 1 = Standard RPM/Standard Blower Motor  
 • E, 5 = High RPM/Large Blower Motor  
 • The maximum allowable altitude of installation for this product is 6,561 ft (2,000 m).

Models:  
MB  
072-300

# Blower Performance

## MB168 with VFD

SCFM	ESP (in.w.c.)	0.00	0.10	0.20	0.30	0.40	0.50	0.60	0.70	0.80	0.90	1.00	1.10	1.20	1.30	1.40	1.50
4,200	BHP			0.69	0.78	0.86	0.95	1.02	1.11	1.21	1.32	1.41	1.50	1.57	1.64	1.72	1.80
	Discrete Spd Setting			B	B	B	B	A	A	A	A	A	A	A	C	C	C
	RPM			547	594	640	685	725	765	805	845	880	915	945	975	1005	1030
4,400	BHP			0.75	0.83	0.92	1.01	1.11	1.21	1.31	1.41	1.51	1.60	1.68	1.76	1.85	1.94
	Discrete Spd Setting			B	B	B	B	A	A	A	A	A	A	A	C	C	C
	RPM			563	609	655	695	735	775	815	855	890	925	955	985	1015	1045
4,600	BHP		0.75	0.85	0.95	1.03	1.11	1.19	1.30	1.40	1.50	1.60	1.70	1.78	1.89	2.00	2.10
	Discrete Spd Setting		B	B	B	B	B	A	A	A	A	A	A	C	C	C	C
	RPM		526	573	625	665	705	745	785	825	860	895	930	960	995	1025	1050
4,800	BHP		0.83	0.94	1.03	1.12	1.20	1.30	1.40	1.53	1.63	1.73	1.82	1.92	2.00	2.12	2.22
	Discrete Spd Setting		B	B	B	B	A	A	A	A	A	A	A	C	C	C	C
	RPM		542	594	640	680	720	760	795	835	870	905	935	970	1000	1030	1055
5,000	BHP		0.93	1.02	1.11	1.20	1.31	1.41	1.52	1.64	1.76	1.85	1.95	2.03	2.12	2.24	2.36
	Discrete Spd Setting		B	B	B	B	A	A	A	A	A	A	A	C	C	C	C
	RPM		563	609	650	690	735	770	805	840	880	910	945	975	1005	1035	1065
5,200	BHP	0.93	1.02	1.10	1.20	1.29	1.39	1.50	1.61	1.72	1.83	1.94	2.06	2.15	2.26	2.38	2.50
	Discrete Spd Setting	B	B	B	B	B	A	A	A	A	A	A	A	C	C	C	C
	RPM	542	583	625	665	705	745	780	815	850	885	920	955	985	1015	1045	1075
5,400	BHP	1.03	1.10	1.19	1.29	1.39	1.50	1.59	1.70	1.80	1.92	2.03	2.16	2.26	2.38	2.50	2.62
	Discrete Spd Setting	B	B	B	B	B	A	A	A	A	A	A	C	C	C	C	C
	RPM	563	599	640	680	720	760	790	825	860	895	925	960	990	1020	1050	1080
5,600	BHP	1.12	1.19	1.28	1.39	1.50	1.61	1.72	1.84	1.93	2.06	2.17	2.29	2.40	2.54	2.69	2.83
	Discrete Spd Setting	B	B	B	B	A	A	A	A	A	A	A	C	C	C	C	C
	RPM	583	620	655	695	735	770	805	840	870	905	935	970	1000	1030	1060	1090
5,800	BHP	1.17	1.28	1.39	1.49	1.60	1.70	1.81	1.90	2.02	2.14	2.28	2.40	2.52	2.67	2.81	2.96
	Discrete Spd Setting	B	B	B	B	A	A	A	A	A	A	A	C	C	C	C	C
	RPM	588	630	670	710	750	780	815	845	880	910	945	975	1005	1035	1065	1095
6,000	BHP	1.25	1.40	1.51	1.61	1.73	1.84	1.94	2.05	2.18	2.30	2.42	2.54	2.67	2.79	2.94	3.08
	Discrete Spd Setting	B	B	B	A	A	A	A	A	A	A	A	C	C	C	C	C
	RPM	604	645	685	720	760	795	825	860	895	925	955	985	1015	1040	1070	1100
6,200	BHP	1.40	1.51	1.62	1.75	1.86	1.98	2.09	2.20	2.34	2.49	2.63	2.78	2.92	3.06	3.18	
	Discrete Spd Setting	B	B	B	A	A	A	A	A	A	A	C	C	C	C	C	
	RPM	625	660	695	735	770	805	840	875	905	935	965	995	1025	1055	1080	
6,400	BHP	1.55	1.68	1.79	1.90	2.04	2.18	2.32	2.44	2.56	2.68	2.80	2.92	3.07	3.19	3.33	
	Discrete Spd Setting	B	B	B	A	A	A	A	A	A	A	C	C	C	C	C	
	RPM	640	680	715	750	785	820	855	885	915	945	975	1005	1035	1060	1090	
6,600	BHP	1.73	1.84	1.94	2.06	2.20	2.34	2.46	2.58	2.70	2.82	2.94	3.07	3.19	3.34	3.46	
	Discrete Spd Setting	B	B	A	A	A	A	A	A	A	A	C	C	C	C	C	
	RPM	665	700	730	765	800	835	865	895	925	955	985	1015	1040	1070	1095	
6,800	BHP	1.87	1.98	2.08	2.20	2.34	2.48	2.62	2.74	2.86	2.96	3.08	3.24	3.38	3.55		
	Discrete Spd Setting	B	B	A	A	A	A	A	A	A	C	C	C	C	C		
	RPM	685	715	745	775	810	845	880	910	940	965	995	1025	1050	1080		
7,000	BHP	2.03	2.13	2.22	2.36	2.50	2.62	2.76	2.88	3.00	3.12	3.22	3.37	3.49	3.61		
	Discrete Spd Setting	B	A	A	A	A	A	A	A	A	C	C	C	C	C		
	RPM	705	730	755	790	825	855	890	920	950	980	1005	1035	1060	1085		

Notes:

- Motor Sheave set to 1-turn open from factory.
- Factory torque setting is A. Torque setting is field-adjustable to any torque setting listed in drive table through the Wireless Service Tool.
- The unit can control the blower through LAT control. Enable this setting in the field with the Wireless Service Tool.
- The maximum allowable altitude of installation for this product is 6,561 ft (2,000 m).

# Blower Performance MB192

Models:  
MB  
072-300

SCFM	ESP (in.w.c.)	0.00	0.10	0.20	0.30	0.40	0.50	0.60	0.70	0.80	0.90	1.00	1.10	1.20	1.30	1.40	1.50
4,800	BHP		0.98	1.07	1.16	1.24	1.34	1.47	1.59	1.69	1.78	1.87	1.96	2.06	2.18	2.30	2.42
	Sheave/Mtr		B	B	B	B	A	A	A	A	A	A	A	C	C	C	C
	RPM		615	660	700	740	775	815	855	890	920	955	985	1015	1045	1075	1105
5,000	BHP	0.99	1.07	1.18	1.27	1.37	1.49	1.60	1.73	1.82	1.92	2.00	2.10	2.22	2.32	2.44	2.56
	Sheave/Mtr	B	B	B	B	A	A	A	A	A	A	A	A	C	C	C	C
	RPM	594	635	680	720	760	795	830	870	900	935	965	1000	1030	1055	1085	1115
5,200	BHP	1.09	1.18	1.28	1.36	1.48	1.59	1.70	1.82	1.93	2.02	2.14	2.24	2.36	2.48	2.60	2.72
	Sheave/Mtr	B	B	B	B	A	A	A	A	A	A	A	C	C	C	C	C
	RPM	620	660	700	735	775	810	845	880	915	945	980	1010	1040	1070	1100	1130
5,400	BHP	1.19	1.29	1.39	1.48	1.59	1.70	1.80	1.92	2.03	2.16	2.26	2.38	2.50	2.62	2.74	2.87
	Sheave/Mtr	B	B	B	A	A	A	A	A	A	A	A	C	C	C	C	C
	RPM	640	680	720	755	790	825	860	895	925	960	990	1020	1050	1080	1110	1140
5,600	BHP	1.30	1.40	1.51	1.62	1.74	1.85	1.95	2.08	2.18	2.31	2.42	2.57	2.71	2.86	2.98	3.12
	Sheave/Mtr	B	B	B	A	A	A	A	A	A	A	C	C	C	C	C	E
	RPM	660	700	740	775	810	845	875	910	940	975	1005	1035	1065	1095	1120	1150
5,800	BHP	1.41	1.52	1.63	1.73	1.84	1.95	2.06	2.18	2.32	2.44	2.57	2.72	2.86	3.00	3.15	3.27
	Sheave/Mtr	B	B	A	A	A	A	A	A	A	A	C	C	C	E	E	E
	RPM	680	720	760	790	825	860	890	920	955	985	1015	1045	1075	1105	1135	1160
6,000	BHP	1.56	1.67	1.78	1.89	2.00	2.12	2.24	2.36	2.48	2.60	2.74	2.89	3.01	3.15	3.30	3.42
	Sheave/Mtr	B	B	A	A	A	A	A	A	A	C	C	C	E	E	E	E
	RPM	700	740	775	810	845	880	910	940	970	1000	1030	1060	1085	1115	1145	1170
6,200	BHP	1.70	1.83	1.94	2.06	2.17	2.30	2.44	2.58	2.73	2.87	3.02	3.14	3.28	3.40	3.54	3.66
	Sheave/Mtr	B	A	A	A	A	A	A	A	A	C	E	E	E	E	E	E
	RPM	720	760	795	830	865	895	925	955	985	1015	1045	1070	1100	1125	1155	1180
6,400	BHP	1.88	2.02	2.16	2.28	2.42	2.54	2.66	2.78	2.90	3.04	3.16	3.31	3.43	3.58	3.72	3.86
	Sheave/Mtr	B	A	A	A	A	A	A	A	C	E	E	E	E	E	E	E
	RPM	745	780	815	845	880	910	940	970	1000	1030	1055	1085	1110	1140	1165	1190
6,600	BHP	2.06	2.18	2.32	2.46	2.58	2.70	2.82	2.94	3.07	3.19	3.34	3.46	3.60	3.74	3.88	4.02
	Sheave/Mtr	A	A	A	A	A	A	A	A	E	E	E	E	E	E	E	E
	RPM	765	795	830	865	895	925	955	985	1015	1040	1070	1095	1125	1150	1175	1200
6,800	BHP	2.22	2.36	2.50	2.62	2.74	2.86	3.00	3.10	3.27	3.41	3.58	3.72	3.85	3.97	4.11	4.23
	Sheave/Mtr	A	A	A	A	A	A	D	D	E	E	E	E	E	E	E	E
	RPM	780	815	850	880	910	940	970	1000	1030	1055	1085	1110	1135	1160	1190	1215

Notes:

- A, 1 = Standard RPM/Standard Blower Motor
- E, 5 = High RPM/Large Blower Motor
- The maximum allowable altitude of installation for this product is 6,561 ft (2,000 m).

Table continued on next page.

Models:  
MB  
072-300

# Blower Performance

## MB192

Table continued from previous page.

SCFM	ESP (in.w.c.)	0.00	0.10	0.20	0.30	0.40	0.50	0.60	0.70	0.80	0.90	1.00	1.10	1.20	1.30	1.40	1.50
7,000	BHP	2.40	2.54	2.66	2.80	2.92	3.04	3.14	3.27	3.39	3.54	3.66	3.78	3.96	4.12	4.28	4.44
	Sheave/Mtr	A	A	A	A	A	D	D	E	E	E	E	E	E	E	E	E
	RPM	800	835	865	900	930	960	985	1015	1040	1070	1095	1120	1150	1175	1200	1225
7,200	BHP	2.58	2.70	2.85	2.99	3.14	3.28	3.42	3.54	3.66	3.81	3.93	4.06	4.22	4.38	4.54	4.70
	Sheave/Mtr	A	A	A	A	D	D	E	E	E	E	E	E	E	E	E	E
	RPM	820	850	885	915	945	975	1005	1030	1055	1085	1110	1135	1160	1185	1210	1235
7,400	BHP	2.76	2.88	3.02	3.16	3.31	3.45	3.61	3.75	3.92	4.06	4.20	4.36	4.52	4.68	4.81	4.97
	Sheave/Mtr	A	A	D	D	D	D	E	E	E	E	E	E	E	E	E	E
	RPM	840	870	900	930	960	990	1020	1045	1075	1100	1125	1150	1175	1200	1220	1245
7,600	BHP	2.94	3.07	3.22	3.36	3.50	3.63	3.82	3.98	4.14	4.34	4.50	4.66	4.78	4.94		
	Sheave/Mtr	A	D	D	D	D	E	E	E	E	E	E	E	E	E		
	RPM	860	890	920	950	980	1005	1035	1060	1085	1115	1140	1165	1185	1210		
7,800	BHP	3.22	3.34	3.49	3.63	3.78	3.96	4.12	4.28	4.44	4.63	4.76	4.92				
	Sheave/Mtr	D	D	D	D	D	E	E	E	E	E	E	E				
	RPM	880	905	935	965	995	1025	1050	1075	1100	1130	1150	1175				
8,000	BHP	3.41	3.58	3.75	3.92	4.06	4.26	4.42	4.58	4.74	4.90						
	Sheave/Mtr	D	D	D	D	E	E	E	E	E	E						
	RPM	895	925	955	985	1010	1040	1065	1090	1115	1140						

Notes:

- A, 1 = Standard RPM/Standard Blower Motor
- E, 5 = High RPM/Large Blower Motor
- The maximum allowable altitude of installation for this product is 6,561 ft (2,000 m).

# Blower Performance MB192 with VFD

Models:  
MB  
072-300

SCFM	ESP (in.w.c.)	0.00	0.10	0.20	0.30	0.40	0.50	0.60	0.70	0.80	0.90	1.00	1.10	1.20	1.30	1.40	1.50
4,800	BHP		0.98	1.07	1.16	1.24	1.34	1.47	1.59	1.69	1.78	1.87	1.96	2.06	2.18	2.30	2.42
	Discrete Spd Setting		B	B	B	B	A	A	A	A	A	A	A	C	C	C	C
	RPM		615	660	700	740	775	815	855	890	920	955	985	1015	1045	1075	1105
5,000	BHP	0.99	1.07	1.18	1.27	1.37	1.49	1.60	1.73	1.82	1.92	2.00	2.10	2.22	2.32	2.44	2.56
	Discrete Spd Setting		B	B	B	B	A	A	A	A	A	A	A	C	C	C	C
	RPM	594	635	680	720	760	795	830	870	900	935	965	1000	1030	1055	1085	1115
5,200	BHP	1.09	1.18	1.28	1.36	1.48	1.59	1.70	1.82	1.93	2.02	2.14	2.24	2.36	2.48	2.60	2.72
	Sheave/Mtr		B	B	B	B	A	A	A	A	A	A	C	C	C	C	C
	RPM	620	660	700	735	775	810	845	880	915	945	980	1010	1040	1070	1100	1130
5,400	BHP	1.19	1.29	1.39	1.48	1.59	1.70	1.80	1.92	2.03	2.16	2.26	2.38	2.50	2.62	2.74	2.87
	Discrete Spd Setting		B	B	B	A	A	A	A	A	A	A	C	C	C	C	C
	RPM	640	680	720	755	790	825	860	895	925	960	990	1020	1050	1080	1110	1140
5,600	BHP	1.30	1.40	1.51	1.62	1.74	1.85	1.95	2.08	2.18	2.31	2.42	2.57	2.71	2.86	2.98	3.12
	Sheave/Mtr		B	B	B	A	A	A	A	A	A	C	C	C	C	C	C
	RPM	660	700	740	775	810	845	875	910	940	975	1005	1035	1065	1095	1120	1150
5,800	BHP	1.41	1.52	1.63	1.73	1.84	1.95	2.06	2.18	2.32	2.44	2.57	2.72	2.86	3.00	3.15	3.27
	Discrete Spd Setting		B	B	A	A	A	A	A	A	A	C	C	C	C	C	C
	RPM	680	720	760	790	825	860	890	920	955	985	1015	1045	1075	1105	1135	1160
6,000	BHP	1.56	1.67	1.78	1.89	2.00	2.12	2.24	2.36	2.48	2.60	2.74	2.89	3.01	3.15	3.30	3.42
	Discrete Spd Setting		B	B	A	A	A	A	A	A	C	C	C	C	C	C	C
	RPM	700	740	775	810	845	880	910	940	970	1000	1030	1060	1085	1115	1145	1170
6,200	BHP	1.70	1.83	1.94	2.06	2.17	2.30	2.44	2.58	2.73	2.87	3.02	3.14	3.28	3.40	3.54	3.66
	Discrete Spd Setting		B	A	A	A	A	A	A	A	C	C	C	C	C	C	C
	RPM	720	760	795	830	865	895	925	955	985	1015	1045	1070	1100	1125	1155	1180
6,400	BHP	1.88	2.02	2.16	2.28	2.42	2.54	2.66	2.78	2.90	3.04	3.16	3.31	3.43	3.58	3.72	3.86
	Discrete Spd Setting		B	A	A	A	A	A	A	C	C	C	C	C	C	C	C
	RPM	745	780	815	845	880	910	940	970	1000	1030	1055	1085	1110	1140	1165	1190
6,600	BHP	2.06	2.18	2.32	2.46	2.58	2.70	2.82	2.94	3.07	3.19	3.34	3.46	3.60	3.74	3.88	4.02
	Discrete Spd Setting		A	A	A	A	A	A	A	C	C	C	C	C	C	C	C
	RPM	765	795	830	865	895	925	955	985	1015	1040	1070	1095	1125	1150	1175	1200
6,800	BHP	2.22	2.36	2.50	2.62	2.74	2.86	3.00	3.10	3.27	3.41	3.58	3.72	3.85	3.97	4.11	4.23
	Discrete Spd Setting		A	A	A	A	A	A	A	C	C	C	C	C	C	C	C
	RPM	780	815	850	880	910	940	970	1000	1030	1055	1085	1110	1135	1160	1190	1215

Notes:

- Motor Sheave set to 1-turn open from factory.
- Factory torque setting is A. Torque setting is field-adjustable to any torque setting listed in drive table through the Wireless Service Tool.
- The unit can control the blower through LAT control. Enable this setting in the field with the Wireless Service Tool.
- The maximum allowable altitude of installation for this product is 6,561 ft (2,000 m).

Table continued on next page.

Models:  
MB  
072-300

# Blower Performance MB192 with VFD

Table continued from previous page.

SCFM	ESP (in.w.c.)	0.00	0.10	0.20	0.30	0.40	0.50	0.60	0.70	0.80	0.90	1.00	1.10	1.20	1.30	1.40	1.50
7,000	BHP	2.40	2.54	2.66	2.80	2.92	3.04	3.14	3.27	3.39	3.54	3.66	3.78	3.96	4.12	4.28	4.44
	Discrete Spd Setting	A	A	A	A	A	A	A	C	C	C	C	C	C	C	C	C
	RPM	800	835	865	900	930	960	985	1015	1040	1070	1095	1120	1150	1175	1200	1225
7,200	BHP	2.58	2.70	2.85	2.99	3.14	3.28	3.42	3.54	3.66	3.81	3.93	4.06	4.22	4.38	4.54	4.70
	Discrete Spd Setting	A	A	A	A	A	A	C	C	C	C	C	C	C	C	C	C
	RPM	820	850	885	915	945	975	1005	1030	1055	1085	1110	1135	1160	1185	1210	1235
7,400	BHP	2.76	2.88	3.02	3.16	3.31	3.45	3.61	3.75	3.92	4.06	4.20	4.36	4.52	4.68	4.81	4.97
	Discrete Spd Setting	A	A	A	A	A	A	C	C	C	C	C	C	C	C	C	C
	RPM	840	870	900	930	960	990	1020	1045	1075	1100	1125	1150	1175	1200	1220	1245
7,600	BHP	2.94	3.07	3.22	3.36	3.50	3.63	3.82	3.98	4.14	4.34	4.50	4.66	4.78	4.94		
	Discrete Spd Setting	A	D	D	D	D	C	C	C	C	C	C	C	C	C		
	RPM	860	890	920	950	980	1005	1035	1060	1085	1115	1140	1165	1185	1210		
7,800	BHP	3.22	3.34	3.49	3.63	3.78	3.96	4.12	4.28	4.44	4.63	4.76	4.92				
	Discrete Spd Setting	A	A	A	A	A	C	C	C	C	C	C					
	RPM	880	905	935	965	995	1025	1050	1075	1100	1130	1150	1175				
8,000	BHP	3.41	3.58	3.75	3.92	4.06	4.26	4.42	4.58	4.74	4.90						
	Discrete Spd Setting	A	A	A	A	C	C	C	C	C	C						
	RPM	895	925	955	985	1010	1040	1065	1090	1115	1140						

Notes:

- Motor Sheave set to 1-turn open from factory.
- Factory torque setting is A. Torque setting is field-adjustable to any torque setting listed in drive table through the Wireless Service Tool.
- The unit can control the blower through LAT control. Enable this setting in the field with the Wireless Service Tool.
- The maximum allowable altitude of installation for this product is 6,561 ft (2,000 m).

# Blower Performance MB240

Models:  
MB  
072-300

SCFM	ESP (in.w.c.)	0.00	0.10	0.20	0.30	0.40	0.50	0.60	0.70	0.80	0.90	1.00	1.10	1.20	1.30	1.40	1.50	
6,000	BHP				1.78	1.89	2.00	2.12	2.24	2.36	2.48	2.60	2.74	2.89	3.01	3.15	3.30	
	Sheave/Mtr				B	B	B	A	A	A	A	A	A	A	A	C	C	
	RPM				775	810	845	880	910	940	970	1000	1030	1060	1085	1115	1145	
6,200	BHP			1.82	1.93	2.04	2.15	2.30	2.44	2.58	2.73	2.87	2.99	3.14	3.26	3.40	3.52	
	Sheave/Mtr				B	B	B	B	A	A	A	A	A	A	C	C	C	
	RPM				755	790	825	860	895	925	955	985	1015	1040	1070	1095	1125	1150
6,400	BHP			2.00	2.14	2.26	2.40	2.52	2.64	2.76	2.88	3.02	3.14	3.28	3.40	3.56	3.70	
	Sheave/Mtr				B	B	B	B	A	A	A	A	A	A	C	C	C	
	RPM				775	810	840	875	905	935	965	995	1025	1050	1080	1105	1135	1160
6,600	BHP		2.02	2.16	2.30	2.42	2.56	2.68	2.80	2.92	3.05	3.17	3.29	3.43	3.55	3.71	3.85	
	Sheave/Mtr			B	B	B	B	A	A	A	A	A	A	A	C	C	C	
	RPM			755	790	825	855	890	920	950	980	1010	1035	1060	1090	1115	1145	1170
6,800	BHP		2.18	2.32	2.46	2.58	2.70	2.84	2.94	3.06	3.21	3.35	3.52	3.66	3.82	3.94	4.06	
	Sheave/Mtr			B	B	B	B	A	A	A	A	A	A	C	C	C	C	
	RPM			770	805	840	870	900	935	960	990	1020	1045	1075	1100	1130	1155	1180
7,000	BHP	2.22	2.34	2.48	2.62	2.74	2.86	2.98	3.10	3.22	3.34	3.49	3.61	3.73	3.90	4.06	4.22	
	Sheave/Mtr		B	B	B	B	A	A	A	A	A	A	A	A	C	C	C	C
	RPM		755	785	820	855	885	915	945	975	1005	1030	1060	1085	1110	1140	1165	1190
7,200	BHP	2.38	2.52	2.64	2.78	2.92	3.06	3.21	3.35	3.47	3.62	3.74	3.88	4.00	4.16	4.32	4.48	
	Sheave/Mtr		B	B	B	B	A	A	A	A	A	A	A	C	C	C	C	C
	RPM		770	805	835	870	900	930	960	990	1015	1045	1070	1100	1125	1150	1175	1200
7,400	BHP	2.56	2.68	2.82	2.95	3.09	3.24	3.38	3.53	3.67	3.84	3.98	4.12	4.26	4.42	4.58	4.74	
	Sheave/Mtr		B	B	B	A	A	A	A	A	A	A	A	C	C	C	C	C
	RPM		790	820	855	885	915	945	975	1005	1030	1060	1085	1110	1135	1160	1185	1210
7,600	BHP	2.74	2.86	2.98	3.12	3.26	3.41	3.55	3.70	3.89	4.05	4.21	4.40	4.53	4.69	4.85		
	Sheave/Mtr		B	B	B	A	A	A	A	A	A	A	C	C	C	C		
	RPM		810	840	870	900	930	960	990	1015	1045	1070	1095	1125	1145	1170	1195	
7,800	BHP	2.98	3.13	3.25	3.39	3.54	3.68	3.83	3.99	4.15	4.34	4.50	4.66	4.82	4.95			
	Sheave/Mtr		B	B	A	A	A	A	A	A	A	C	C	C	C			
	RPM		830	860	885	915	945	975	1005	1030	1055	1085	1110	1135	1160	1180		
8,000	BHP	3.18	3.30	3.44	3.61	3.78	3.94	4.10	4.29	4.45	4.61	4.77	4.93					
	Sheave/Mtr		B	B	A	A	A	A	A	A	A	C	C	C				
	RPM		850	875	900	930	960	990	1015	1045	1070	1095	1120	1145				

- Notes:
- A, 1 = Standard RPM/Standard Blower Motor
  - E, 5 = High RPM/Large Blower Motor
  - The maximum allowable altitude of installation for this product is 6,561 ft (2,000 m).

Table continued on next page.

Models:  
MB  
072-300

# Blower Performance

## MB240

Table continued from previous page.

SCFM	ESP (in.w.c.)	0.00	0.10	0.20	0.30	0.40	0.50	0.60	0.70	0.80	0.90	1.00	1.10	1.20	1.30	1.40	1.50	
8,200	BHP	3.35	3.48	3.65	3.79	3.96	4.13	4.27	4.44	4.58	4.72	4.88						
	Sheave/Mtr	B	A	A	A	A	A	A	A	A	C	C						
	RPM	865	890	920	945	975	1005	1030	1060	1085	1110	1135						
8,400	BHP	3.62	3.74	3.89	4.03	4.18	4.33	4.49	4.65	4.81	4.97							
	Sheave/Mtr	A	A	A	A	A	A	A	A	C	C							
	RPM	880	905	935	965	995	1020	1045	1070	1095	1120							
8,600	BHP	3.81	3.98	4.12	4.29	4.46	4.62	4.78	4.94									
	Sheave/Mtr	A	A	A	A	A	A	A	A									
	RPM	895	925	950	980	1010	1035	1060	1085									
8,800	BHP	4.06	4.22	4.41	4.57	4.73	4.92											
	Sheave/Mtr	A	A	A	A	A	A											
	RPM	915	940	970	995	1020	1050											
9,000	BHP	4.38	4.54	4.70	4.86													
	Sheave/Mtr	A	A	A	A													
	RPM	935	960	985	1010													
9,200	BHP	4.65	4.76	4.90														
	Sheave/Mtr	A	A	A														
	RPM	955	975	1000														
9,400	BHP	4.83	4.94															
	Sheave/Mtr	A	A															
	RPM	970	990															
9,600	BHP																	
	Sheave/Mtr																	
	RPM																	

Notes:

- A, 1 = Standard RPM/Standard Blower Motor
- E, 5 = High RPM/Large Blower Motor
- The maximum allowable altitude of installation for this product is 6,561 ft (2,000 m).

# Blower Performance MB240 with VFD

Models:  
MB  
072-300

SCFM	ESP (in.w.c.)	0.00	0.10	0.20	0.30	0.40	0.50	0.60	0.70	0.80	0.90	1.00	1.10	1.20	1.30	1.40	1.50		
6,000	BHP				1.78	1.89	2.00	2.12	2.24	2.36	2.48	2.60	2.74	2.89	3.01	3.15	3.30		
	Discrete Spd Setting				B	B	B	A	A	A	A	A	A	A	A	C	C		
	RPM				775	810	845	880	910	940	970	1000	1030	1060	1085	1115	1145		
6,200	BHP			1.82	1.93	2.04	2.15	2.30	2.44	2.58	2.73	2.87	2.99	3.14	3.26	3.40	3.52		
	Discrete Spd Setting				B	B	B	A	A	A	A	A	A	A	C	C	C		
	RPM				755	790	825	860	895	925	955	985	1015	1040	1070	1095	1125	1150	
6,400	BHP			2.00	2.14	2.26	2.40	2.52	2.64	2.76	2.88	3.02	3.14	3.28	3.40	3.56	3.70		
	Discrete Spd Setting				B	B	B	B	A	A	A	A	A	A	C	C	C		
	RPM				775	810	840	875	905	935	965	995	1025	1050	1080	1105	1135	1160	
6,600	BHP		2.02	2.16	2.30	2.42	2.56	2.68	2.80	2.92	3.05	3.17	3.29	3.43	3.55	3.71	3.85		
	Discrete Spd Setting				B	B	B	B	A	A	A	A	A	A	C	C	C		
	RPM				755	790	825	855	890	920	950	980	1010	1035	1060	1090	1115	1145	1170
6,800	BHP		2.18	2.32	2.46	2.58	2.70	2.84	2.94	3.06	3.21	3.35	3.52	3.66	3.82	3.94	4.06		
	Discrete Spd Setting				B	B	B	B	A	A	A	A	A	C	C	C	C		
	RPM				770	805	840	870	900	935	960	990	1020	1045	1075	1100	1130	1155	1180
7,000	BHP	2.22	2.34	2.48	2.62	2.74	2.86	2.98	3.10	3.22	3.34	3.49	3.61	3.73	3.90	4.06	4.22		
	Discrete Spd Setting				B	B	B	B	A	A	A	A	A	C	C	C	C		
	RPM				755	785	820	855	885	915	945	975	1005	1030	1060	1085	1110	1140	1165
7,200	BHP	2.38	2.52	2.64	2.78	2.92	3.06	3.21	3.35	3.47	3.62	3.74	3.88	4.00	4.16	4.32	4.48		
	Discrete Spd Setting				B	B	B	B	A	A	A	A	A	C	C	C	C		
	RPM				770	805	835	870	900	930	960	990	1015	1045	1070	1100	1125	1150	1175
7,400	BHP	2.56	2.68	2.82	2.95	3.09	3.24	3.38	3.53	3.67	3.84	3.98	4.12	4.26	4.42	4.58	4.74		
	Discrete Spd Setting				B	B	B	A	A	A	A	A	A	C	C	C	C		
	RPM				790	820	855	885	915	945	975	1005	1030	1060	1085	1110	1135	1160	1185
7,600	BHP	2.74	2.86	2.98	3.12	3.26	3.41	3.55	3.70	3.89	4.05	4.21	4.40	4.53	4.69	4.85	5.01		
	Discrete Spd Setting				B	B	B	A	A	A	A	A	C	C	C	C	C		
	RPM				810	840	870	900	930	960	990	1015	1045	1070	1095	1125	1145	1170	1195
7,800	BHP	2.98	3.13	3.25	3.39	3.54	3.68	3.83	3.99	4.15	4.34	4.50	4.66	4.82	4.95	5.11	5.27		
	Discrete Spd Setting				B	B	A	A	A	A	A	C	C	C	C	C	C		
	RPM				830	860	885	915	945	975	1005	1030	1055	1085	1110	1135	1160	1180	1205
8,000	BHP	3.18	3.30	3.44	3.61	3.78	3.94	4.10	4.29	4.45	4.61	4.77	4.93	5.09	5.25	5.38	5.54		
	Discrete Spd Setting				B	B	A	A	A	A	A	C	C	C	C	C	C		
	RPM				850	875	900	930	960	990	1015	1045	1070	1095	1120	1145	1170	1195	1215

Notes:

- Motor Sheave set to 1-turn open from factory.
- Factory torque setting is A. Torque setting is field-adjustable to any torque setting listed in drive table through the Wireless Service Tool.
- The unit can control the blower through LAT control. Enable this setting in the field with the Wireless Service Tool.
- The maximum allowable altitude of installation for this product is 6,561 ft (2,000 m).

Table continued on next page.

Models:  
MB  
072-300

# Blower Performance MB240 with VFD

Table continued from previous page.

SCFM	ESP (in.w.c.)	0.00	0.10	0.20	0.30	0.40	0.50	0.60	0.70	0.80	0.90	1.00	1.10	1.20	1.30	1.40	1.50
8,200	BHP	3.35	3.48	3.65	3.79	3.96	4.13	4.27	4.44	4.58	4.72	4.88	5.08	5.24	5.44	5.64	
	Discrete Spd Setting	B	A	A	A	A	A	A	A	A	C	C	C	C	C	C	
	RPM	865	890	920	945	975	1005	1030	1060	1085	1110	1135	1160	1180	1205	1230	
8,400	BHP	3.62	3.74	3.89	4.03	4.18	4.33	4.49	4.65	4.81	4.97	5.16	5.36	5.56	5.72	5.92	
	Discrete Spd Setting	A	A	A	A	A	A	A	A	C	C	C	C	C	C	C	
	RPM	880	905	935	965	995	1020	1045	1070	1095	1120	1145	1170	1195	1215	1240	
8,600	BHP	3.81	3.98	4.12	4.29	4.46	4.62	4.78	4.94	5.10	5.28	5.48	5.64	5.84	6.04	6.20	
	Discrete Spd Setting	A	A	A	A	A	A	A	A	C	C	C	C	C	C	C	
	RPM	895	925	950	980	1010	1035	1060	1085	1110	1135	1160	1180	1205	1230	1250	
8,800	BHP	4.06	4.22	4.41	4.57	4.73	4.92	5.08	5.24	5.40	5.60	5.76	5.96	6.16	6.32		
	Discrete Spd Setting	A	A	A	A	A	A	A	C	C	C	C	C	C	C		
	RPM	915	940	970	995	1020	1050	1075	1100	1125	1150	1170	1195	1220	1240		
9,000	BHP	4.38	4.54	4.70	4.86	5.02	5.18	5.34	5.50	5.68	5.88	6.08	6.24				
	Sheave/Mtr	A	A	A	A	A	A	A	C	C	C	C	C				
	RPM	935	960	985	1010	1035	1060	1085	1110	1135	1160	1185	1205				
	Turns Open	4.5	4	3.5	3	2	1.5	1	3.5	3	2.5	2	1.5				
9,200	BHP	4.65	4.76	4.90	5.08	5.26	5.44	5.62	5.80	6.00	6.16						
	Discrete Spd Setting	A	A	A	A	A	A	C	C	C	C						
	RPM	955	975	1000	1025	1050	1075	1100	1125	1150	1170						
9,400	BHP	4.83	4.94	5.12	5.32	5.52	5.72	5.92	6.12	6.32	6.48						
	Discrete Spd Setting	A	A	A	A	A	A	C	C	C	C						
	RPM	970	990	1015	1040	1065	1090	1115	1140	1165	1185						
9,600	BHP	5.10	5.24	5.44	5.64	5.84	6.04	6.24	6.40								
	Discrete Spd Setting	A	A	A	A	A	C	C	C								
	RPM	985	1005	1030	1055	1080	1105	1130	1150								

Notes:

- Motor Sheave set to 1-turn open from factory.
- Factory torque setting is A. Torque setting is field-adjustable to any torque setting listed in drive table through the Wireless Service Tool.
- The unit can control the blower through LAT control. Enable this setting in the field with the Wireless Service Tool.
- The maximum allowable altitude of installation for this product is 6,561 ft (2,000 m).

# Blower Performance MB300

Models:  
MB  
072-300

SCFM	ESP (in.w.c.)	0.00	0.10	0.20	0.30	0.40	0.50	0.60	0.70	0.80	0.90	1.00	1.10	1.20	1.30	1.40	1.50
8,100	RPM	935	965	995	1025	1055	1085	1115	1145	1170	1195	1220	1245	1265	1285	1310	1330
8,400	BHP	3.36	3.52	3.74	3.92	4.14	4.36	4.57	4.75	4.93	5.11	5.29	5.47	5.62	5.80	5.94	6.12
	Sheave/Mtr	B	B	A	A	A	A	A	A	A	A	A	C	C	C	C	C
8,700	RPM	955	985	1020	1045	1075	1105	1135	1160	1185	1210	1235	1260	1280	1305	1325	1350
	BHP	3.60	3.79	4.00	4.22	4.43	4.65	4.83	5.01	5.19	5.37	5.55	5.76	5.97	6.14	6.35	6.56
9,000	Sheave/Mtr	B	A	A	A	A	A	A	A	A	A	C	C	C	C	C	C
	RPM	975	1005	1035	1065	1095	1125	1150	1175	1200	1225	1250	1275	1300	1320	1345	1370
9,300	BHP	3.90	4.12	4.30	4.51	4.73	4.91	5.09	5.30	5.48	5.66	5.89	6.08	6.32	6.56	6.76	
	Sheave/Mtr	A	A	A	A	A	A	A	A	A	C	C	C	C	C	C	
9,600	RPM	1000	1030	1055	1085	1115	1140	1165	1195	1220	1245	1270	1290	1315	1340	1360	
	BHP	4.34	4.56	4.74	4.96	5.14	5.35	5.53	5.71	5.89	6.08	6.29	6.50	6.67	6.88	7.05	
9,900	Sheave/Mtr	A	A	A	A	A	A	A	A	A	C	C	C	C	C	C	
	RPM	1020	1050	1075	1105	1130	1160	1185	1210	1235	1260	1285	1310	1330	1355	1375	
10,200	BHP	4.64	4.85	5.03	5.25	5.46	5.67	5.88	6.13	6.34	6.52	6.66	6.84	7.02	7.16		
	Sheave/Mtr	A	A	A	A	A	A	A	A	C	C	C	C	C	C		
10,500	RPM	1040	1070	1095	1125	1150	1175	1200	1230	1255	1280	1300	1325	1350	1370		
	BHP	4.93	5.15	5.33	5.53	5.78	5.99	6.20	6.41	6.62	6.83	7.04	7.21	7.42			
10,800	Sheave/Mtr	A	A	A	A	A	A	A	C	C	C	C	C				
	RPM	1060	1090	1115	1140	1170	1195	1220	1245	1270	1295	1320	1340	1365			
11,100	BHP	5.36	5.57	5.77	5.95	6.17	6.35	6.53	6.74	6.94	7.18	7.42	7.61				
	Sheave/Mtr	A	A	A	A	A	A	C	C	C	C	C	E				
11,400	RPM	1085	1110	1135	1160	1190	1215	1240	1265	1285	1310	1335	1355				
	BHP	5.52	5.75	5.99	6.23	6.47	6.71	6.95	7.19	7.43	7.62	7.86	8.10				
11,700	Sheave/Mtr	A	A	A	A	A	A	C	C	C	E	E	E				
	RPM	1100	1130	1155	1180	1205	1230	1255	1280	1305	1325	1350	1375				
12,000	BHP	6.00	6.24	6.48	6.72	6.96	7.20	7.39	7.63	7.87	8.11	8.30					
	Sheave/Mtr	A	A	A	A	A	C	C	E	E	E	E					
12,300	RPM	1125	1150	1175	1200	1225	1250	1270	1295	1320	1345	1365					

- Notes:
- A, 1 = Standard RPM/Standard Blower Motor
  - E, 5 = High RPM/Large Blower Motor
  - The maximum allowable altitude of installation for this product is 6,561 ft (2,000 m).

Models:  
MB  
072-300

# Blower Performance MB300 with VFD

SCFM	ESP (in.w.c.)	0.00	0.10	0.20	0.30	0.40	0.50	0.60	0.70	0.80	0.90	1.00	1.10	1.20	1.30	1.40	1.50
7,500	BHP	2.69	2.84	2.96	3.11	3.27	3.45	3.60	3.78	3.96	4.08	4.23	4.38	4.53	4.69	4.86	5.03
	Discrete Spd Setting	B	B	B	B	A	A	A	A	A	A	A	A	A	C	C	C
	RPM	890	925	955	990	1020	1050	1075	1105	1135	1155	1180	1205	1230	1255	1275	1295
7,800	BHP	2.87	3.04	3.18	3.36	3.54	3.72	3.87	4.05	4.20	4.35	4.50	4.65	4.80	4.97	5.14	5.30
	Discrete Spd Setting	B	B	B	A	A	A	A	A	A	A	A	A	C	C	C	C
	RPM	910	945	975	1010	1040	1070	1095	1125	1150	1175	1200	1225	1250	1270	1290	1310
8,100	BHP	3.10	3.26	3.42	3.60	3.78	3.96	4.14	4.34	4.52	4.70	4.88	5.06	5.21	5.35	5.53	5.68
	Discrete Spd Setting	B	B	B	A	A	A	A	A	A	A	A	C	C	C	C	C
	RPM	935	965	995	1025	1055	1085	1115	1145	1170	1195	1220	1245	1265	1285	1310	1330
8,400	BHP	3.36	3.52	3.74	3.92	4.14	4.36	4.57	4.75	4.93	5.11	5.29	5.47	5.62	5.80	5.94	6.12
	Discrete Spd Setting	B	B	A	A	A	A	A	A	A	A	A	C	C	C	C	C
	RPM	955	985	1020	1045	1075	1105	1135	1160	1185	1210	1235	1260	1280	1305	1325	1350
8,700	BHP	3.60	3.79	4.00	4.22	4.43	4.65	4.83	5.01	5.19	5.37	5.55	5.76	5.97	6.14	6.35	6.56
	Discrete Spd Setting	B	A	A	A	A	A	A	A	A	A	C	C	C	C	C	C
	RPM	975	1005	1035	1065	1095	1125	1150	1175	1200	1225	1250	1275	1300	1320	1345	1370
9,000	BHP	3.90	4.12	4.30	4.51	4.73	4.91	5.09	5.30	5.48	5.66	5.89	6.08	6.32	6.56	6.76	
	Discrete Spd Setting	A	A	A	A	A	A	A	A	A	C	C	C	C	C	C	
	RPM	1000	1030	1055	1085	1115	1140	1165	1195	1220	1245	1270	1290	1315	1340	1360	
9,300	BHP	4.34	4.56	4.74	4.96	5.14	5.35	5.53	5.71	5.89	6.08	6.29	6.50	6.67	6.88	7.05	
	Discrete Spd Setting	A	A	A	A	A	A	A	A	A	C	C	C	C	C	C	
	RPM	1020	1050	1075	1105	1130	1160	1185	1210	1235	1260	1285	1310	1330	1355	1375	
9,600	BHP	4.64	4.85	5.03	5.25	5.46	5.67	5.88	6.13	6.34	6.52	6.66	6.84	7.02	7.16		
	Discrete Spd Setting	A	A	A	A	A	A	A	A	C	C	C	C	C	C		
	RPM	1040	1070	1095	1125	1150	1175	1200	1230	1255	1280	1300	1325	1350	1370		
9,900	BHP	4.93	5.15	5.33	5.53	5.78	5.99	6.20	6.41	6.62	6.83	7.04	7.21	7.42			
	Discrete Spd Setting	A	A	A	A	A	A	A	C	C	C	C	C	C			
	RPM	1060	1090	1115	1140	1170	1195	1220	1245	1270	1295	1320	1340	1365			
10,200	BHP	5.36	5.57	5.77	5.95	6.17	6.35	6.53	6.74	6.94	7.18						
	Discrete Spd Setting	A	A	A	A	A	A	C	C	C	C						
	RPM	1085	1110	1135	1160	1190	1215	1240	1265	1285	1310						
10,500	BHP	5.52	5.75	5.99	6.23	6.47	6.71	6.95	7.19								
	Discrete Spd Setting	A	A	A	A	A	A	C	C								
	RPM	1100	1130	1155	1180	1205	1230	1255	1280								
10,800	BHP	6.00	6.24	6.48	6.72	6.96	7.20	7.39	7.63								
	Discrete Spd Setting	A	A	A	A	A	C	C	C								
	RPM	1125	1150	1175	1200	1225	1250	1270	1295								

Notes:

- Motor Sheave set to 1-turn open from factory.
- Factory torque setting is A. Torque setting is field-adjustable to any torque setting listed in drive table through the Wireless Service Tool
- The unit can control the blower through LAT control. Enable this setting in the field with the Wireless Service Tool.
- The maximum allowable altitude of installation for this product is 6,561 ft (2,000 m).

# Operating Limits and Commissioning Conditions

## OPERATING LIMITS

**Environment** – Units are designed for indoor installation only. Never install units in areas subject to freezing or where humidity levels could cause cabinet condensation (such as unconditioned spaces subject to 100% outside air).

**Power Supply** – Voltage utilization shall comply with AHRI Standard 110 or values provided in the *Electrical Data* section.

Three factors determine the operating limits of water-source heat pumps: return air temperature, water temperature, and ambient temperature. When any one of these factors is at minimum or maximum levels, the other two factors should be at normal levels to ensure proper unit operation. Extreme variations in temperature and humidity and/or corrosive water or air adversely affects unit performance, reliability, and service life.

**Table 11: Operating Limits**

Operating Limits	Cooling	Heating
<b>Air Limits</b>		
Min. ambient air, DB <sup>1 3</sup>	10°F [-12°C]	10°F [-12°C]
Max. ambient air, DB <sup>3</sup>	130°F [54.4°C]	130°F [54.4°C]
Min. entering air, DB/WB	60/50°F [16/10°C]	50°F [10°C]
Max. entering air, DB/WB	90/73°F [32/23°C]	80°F [27°C]
Min/Max Airflow (CFM/Ton) <sup>2</sup>	300 to 500 CFM/Ton	
<b>Water Limits</b>		
Min. entering water (072-120) <sup>1</sup>	30°F [-1°C]	20°F [-6.7°C]
Min. entering water (168-300) <sup>1</sup>	30°F [-1°C]	30°F [-1°C]
Operating range	50-110°F [10-43°C]	30-70°F [-1 to 21°C]
Max. entering water	120°F [49°C]	90°F [32°C]
Water Flow Range <sup>3</sup>	1.5 to 3.0 gpm/ton [1.6 to 3.2 l/m per kW]	

**Notes:**

1. Circulating fluid shall be protected to ensure that freezing will not occur when not in operation.
2. All information is provided at rated cfm (400cfm/ton).
3. For units equipped with flow-control automation, cooling & heating min/max ambient temps are 15°F (-9°C) / 120°F (49°C).

### Unit Maximum Water Working Pressure

Configuration	Max Pressure PSIG [kPa]
Base Unit	300 [2,068]
MWV	300 [2,068]
MOD Valve	300 [2,068]

Use the lowest maximum pressure rating when multiple options are combined.

## COMMISSIONING CONDITIONS

Starting conditions vary depending upon model and are based upon the following notes:

**NOTES:**

1. Commissioning Conditions are not normal or continuous operating conditions. Minimum/maximum limits are startup conditions to bring the building space up to occupancy temperatures. Units are not designed to operate under these conditions on a regular basis.
2. Voltage utilization range complies with AHRI Standard 110.

**Table 12: Commissioning Conditions**

Commissioning Conditions	Cooling	Heating
<b>Air Limits</b>		
Min. ambient air, DB <sup>1 3</sup>	10°F [-12°C]	10°F [-12°C]
Max. ambient air, DB <sup>3</sup>	130°F [54°C]	130°F [54°C]
Min. entering air, DB/WB	60/50°F [16/10°C]	50°F [10°C] <sup>5</sup>
Max. entering air, DB/WB	90/73°F [32/23°C] <sup>4</sup>	80°F [27°C]
Min/Max Airflow (CFM/Ton) <sup>2</sup>	300 to 500 CFM/Ton	
<b>Water Limits</b>		
Min. entering water (072-120) <sup>1</sup>	30°F [-6.7°C]	20°F [-6.7°C]
Min. entering water (168-300) <sup>1</sup>	30°F [-1°C]	30°F [-1°C]
Operating range	50-110°F [10-43°C]	30-70°F [-1 to 21°C]
Max. entering water	120°F [49°C]	90°F [32°C]
Water Flow Range <sup>3</sup>	1.5 to 3.0 gpm/ton [1.6 to 3.2 l/m per kW]	

**Notes:**

1. Circulating fluid shall be protected to ensure that freezing will not occur when not in operation.
2. All information is provided at rated cfm (400cfm/ton).
3. For units equipped with flow-control automation, cooling & heating min/max ambient temps are 15°F (-9°C) / 120°F (49°C).
4. Commission units for cooling at entering air temperatures of 100/75°F [38/24°C] only at rated water flow or 3 gpm/ton.
5. Commission units for heating at entering air temperature of 40°F [4.4°C] only at rated water flow or 3 gpm/ton.

Models:  
MB  
072-300

## Piping System Cleaning and Flushing

### PIPING SYSTEM CLEANING AND FLUSHING

Cleaning and flushing the WLHP piping system is the single most important step to ensure proper startup and continued efficient operation of the system.

Follow the instructions below to properly clean and flush the system:

1. Ensure that electrical power to the unit is disconnected.
2. Install the system with the supply hose connected directly to the return riser valve. Use a single length of flexible hose.
3. Fill the system with water. DO NOT allow system to overflow. Bleed all air from the system. Pressurize and check the system for leaks and repair as appropriate. Models with Waterside Economizer also manually open economizer valve and coil air vents (2) to bleed air from coil.
4. Verify that all strainers are in place (the manufacturer recommends a strainer with a #20 stainless-steel wire mesh). Start the pumps, and systematically check each vent to ensure that all air is bled from the system.
5. Verify that make-up water is available. Adjust make-up water as required to replace the air which was bled from the system. Check and adjust the water/air level in the expansion tank.
6. Set the boiler to raise the loop temperature to approximately 86°F [30°C]. Open a drain at the lowest point in the system. Adjust the make-up water replacement rate to equal the rate of bleed.
7. Refill the system and add trisodium phosphate in a proportion of approximately one pound per 150 gallons (0.8 kg per 1000 l) of water (or other equivalent approved cleaning agent) Reset the boiler to raise the loop temperature to 100°F (38°C). Circulate the solution for a minimum of 8 to 24 hours. At the end of this period, shut off the circulating pump and drain the solution. Repeat system cleaning if desired.
8. When the cleaning process is complete, remove the short-circuited hoses. Reconnect the hoses to the proper supply, and return the connections to each of the units. Refill the system and bleed off all air.
9. Test the system pH with litmus paper. The system water should be in the range of pH 6.0 - 8.5 (see the **Water Quality Requirements** table). Add chemicals, as appropriate to maintain neutral pH levels.
10. When the system is successfully cleaned, flushed, refilled and bled, check the main system panels, safety cutouts and alarms. Set the controls to properly maintain loop temperatures.

#### WARNING

Polyolester Oil, commonly known as POE oil, is a synthetic oil used in many refrigeration systems including those with R-454B refrigerant. POE oil, if it ever comes in contact with PVC or CPVC piping, may cause failure of the PVC/CPVC. PVC/CPVC piping should never be used as supply or return water piping with water-source heat pump products containing R-454B as system failures and property damage may result.

#### CAUTION

DO NOT use Stop Leak or similar chemical agent in this system. Addition of chemicals of this type to the loop water will foul the heat exchanger and inhibit unit operation.

**NOTE: The manufacturer strongly recommends all piping connections, both internal and external to the unit, be pressure tested by an appropriate method prior to any finishing of the interior space or before access to all connections is limited. Test pressure may not exceed the maximum allowable pressure for the unit and all components within the water system. The manufacturer will not be responsible or liable for damages from water leaks due to inadequate or lack of a pressurized leak test, or damages caused by exceeding the maximum pressure rating during installation.**

## Unit and System Checkout

### UNIT CHECKOUT

BEFORE POWERING SYSTEM, please check the following:

- Line voltage and wiring:** Verify that voltage is within an acceptable range for the unit and wiring and fuses/breakers are properly sized. Verify that low voltage wiring is complete.
- Unit control transformer:** Ensure that transformer has the properly selected voltage tap.
- Balancing/shutoff valves:** Ensure that all isolation valves are open (after system flushing - see System Checkout) and water control valves are wired.
- Entering water and air:** Ensure that entering water and air temperatures are within operating limits of **Operating Limits** and **Commissioning Conditions** tables.
- Low water temperature cutout:** Verify that low water temperature cut-out on the CXM2 is properly set.
- Unit blower wheel:** Manually rotate blower wheel to verify free rotation and ensure that all blower wheels are secured to the blower motor shaft and centered in housing.
- Blower motor:** Verify motor bolts are tight. DO NOT oil motors upon startup. Fan motors are pre-oiled at the factory.
- Ensure shaft pillow blocks, sheave, and pulley are tight
- Sheave:** Verify sheave has been set to turns in design requirement. Record turns on start up log sheet.
- Belt:** Verify belt is straight and proper tension
- Condensate line:** Verify that condensate line is open, trapped, vented and properly pitched toward drain.
- Water flow balancing:** Record inlet and outlet water temperatures for each heat pump upon startup. This check can eliminate nuisance trip outs and high velocity water flow that could erode heat exchangers.
- Unit air coil and filters:** Ensure that filter is clean and accessible. Clean air coil of all manufacturing oils.
- Unit controls:** Verify that CXM2 field-selection options are properly set.

### SYSTEM CHECKOUT

- System water temperature:** Check water temperature for proper range and also verify heating and cooling setpoints for proper operation.
- System pH:** Check and adjust water pH if necessary to maintain a level between 6 and 8.5. Proper pH promotes longevity of hoses and fittings. Verify these requirements using the **Water Quality Requirements** table.
- System flushing:** Verify that all hoses are connected end to end when flushing to ensure that debris bypasses the unit heat exchanger, water valves and other components. Water used in the system must be potable quality initially and clean of dirt, piping slag, and strong chemical cleaning agents. Verify that all air is purged from the system. Air in the system can cause poor operation or system corrosion.
- Cooling tower/boiler:** Check equipment for proper setpoints and operation.
- Standby pumps:** Verify that the standby pump is properly installed and in operating condition.
- System controls:** Verify that system controls function and operate in the proper sequence.
- Low water temperature cutout:** Verify that low water temperature cut-out controls are provided for the outdoor portion of the loop. Otherwise, operating problems may occur.
- System control center:** Verify that the control center and alarm panel have appropriate setpoints and are operating as designed.
- Miscellaneous:** Note any questionable aspects of the installation.

#### CAUTION

Verify that ALL water control valves are open and allow water flow prior to engaging the compressor. Freezing of the coax or water lines can permanently damage the heat pump.

#### CAUTION

To avoid equipment damage, DO NOT leave system filled in a building without heat during the winter unless antifreeze is added to the water loop. Heat exchangers never fully drain by themselves and will freeze unless winterized with antifreeze.

Models:  
MB  
072-300

## Unit Startup Procedure

1. After checkouts are complete, turn on power to the unit. It is recommended (but not necessary for startup) to plug in the Wireless Service Tool to the port on the corner post. You can check unit configuration and monitor operation during startup. Turn the thermostat fan position to "ON". The blower should start.
2. Balance air flow at registers.
3. Adjust all valves to their full open positions. Turn on the line power to all heat pumps.
4. Room temperature should be within the minimum-maximum ranges of the **Commissioning Conditions** table. During startup checks, loop water temperature entering the heat pump should be within the minimum-maximum ranges of the table above.
5. Three factors determine the operating limits of the manufacturer's heat pumps: return air temperature, water temperature, and ambient temperature. When any one of these factors is at a minimum or maximum level, the other factor must be at normal level to ensure proper unit operation.
  - A. Adjust the unit thermostat to the warmest setting. Place the thermostat mode switch in the "COOL" position. Slowly reduce thermostat setting until the compressor activates.
  - B. Check for cool air delivery at the unit grille within a few minutes after the unit has begun to operate.
 

**NOTE: Bypass the unit's 5-minute time delay in the control circuit on the unit control as shown in the Test Mode Button figure. See the control AOM for specific details.**
  - C. Verify that the compressor is on and that the water flow rate is correct by measuring pressure drop through the heat exchanger using the P/T plugs and comparing to the **Coax Water Pressure Drop** table.
  - D. Check the elevation and cleanliness of the condensate lines. Dripping may be a sign of a blocked line. Check that the condensate trap is filled to provide a water seal. Check the temperature of both entering and leaving water. If temperature is within range, proceed with the test. If temperature is outside of the operating range, check refrigerant pressures and compare to the **Coax Water Pressure Drop** table. Verify correct water flow by comparing unit pressure drop across the heat exchanger versus the data in the **Coax Water Pressure Drop** table. Heat of rejection (HR) can be calculated and compared to submittal data capacity pages. The formula for HR for systems with water is as follows:
 
$$HR \text{ (Btuh)} = TD \times GPM \times 500$$

where TD is the temperature difference between the entering and leaving water, and GPM is the flow rate in U.S. GPM, determined by comparing the pressure drop across the heat exchanger to table 10. In S-I units, the formula is as follows:

$$HR \text{ (kW)} = TD \times l/s \times 4.18$$
  - E. Check air temperature drop across the air coil when compressor is operating. Air temperature drop should be between 15°F and 25°F (8°C and 14°C).
  - F. Turn thermostat to "OFF" position. A hissing noise indicates proper functioning of the reversing valve.
6. Allow fifteen minutes between tests for pressure to equalize before beginning heating test.
  - A. Adjust the thermostat to the lowest setting. Place the thermostat mode switch in the "HEAT" position.
  - B. Slowly raise the thermostat to a higher temperature until the compressor activates.

# Unit Startup Procedure

- C. Check for warm air delivery within a few minutes after the unit has begun to operate.
- D. Use the **Typical Unit Operating Pressures and Temperatures table** for reference. Check the temperature of both entering and leaving water. If temperature is within range, proceed with the test. If temperature is outside of the operating range, check refrigerant pressures and compare to the **Coax Water Pressure Drop** table. Verify correct water flow by comparing unit pressure drop across the heat exchanger versus the data in the **Coax Water Pressure Drop** table. Heat of extraction (HE) can be calculated and compared to submittal data capacity pages. The formula for HE for systems with water is as follows:

$$HE \text{ (Btuh)} = TD \times GPM \times 500$$

where TD is the temperature difference between the entering and leaving water, and GPM is the flow rate in U.S. GPM, determined by comparing the pressure drop across the heat exchanger to the **Coax Water Pressure Drop** table. In S-I units, the formula is as follows:

$$HE \text{ (kW)} = TD \times l/s \times 4.18.$$

- E. Check air temperature rise across the air coil when compressor is operating. Air temperature rise should be between 20°F and 30°F (11°C and 17°C).
  - F. Check for vibration, noise, and water leaks.
7. If unit fails to operate, perform troubleshooting analysis (see troubleshooting section). If the check described fails to reveal the problem and the unit still does not operate, contact a trained service technician to ensure proper diagnosis and repair of the equipment.
8. When testing is complete, set system to maintain desired comfort level.
9. **BE CERTAIN TO FILL OUT AND FORWARD ALL WARRANTY REGISTRATION PAPERS PER YOUR WARRANTY’S REGISTRATION PROCESS.**

**NOTE: If performance during any mode appears abnormal, refer to the CXM2 section or troubleshooting section of this manual. To obtain maximum performance, clean the air coil before startup. A 10% solution of dishwasher detergent and water is recommended.**

**⚠ WARNING**

When the disconnect switch is closed, high voltage is present in some areas of the electrical panel. Exercise caution when working with energized equipment.

**⚠ CAUTION**

Verify that ALL water control valves are open and allow water flow prior to engaging the compressor. Freezing of the coax or water lines can permanently damage the heat pump.

### Test Mode Button

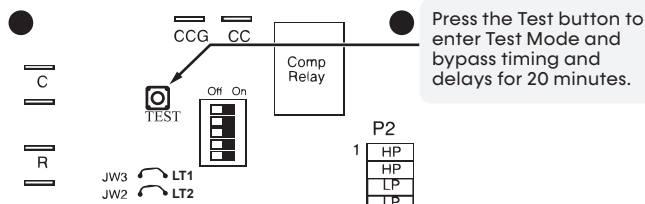

**Table 13: Coax Water Pressure Drop**

Model	GPM	Pressure Drop (psi)				
		30°F <sup>1</sup>	50°F	70°F	90°F	110°F
072	9.00	1.7	1.2	1.0	0.9	0.9
	13.50	3.3	2.4	2.0	2.0	1.8
	18.00	5.1	3.9	3.4	3.2	3.1
096	12.00	2.6	2.1	1.9	1.8	1.7
	18.00	5.4	4.6	4.1	3.8	3.7
	24.00	8.3	7.1	6.4	5.9	5.6
120	15.00	2.8	2.6	2.5	2.4	2.3
	22.50	5.9	5.3	5.0	4.7	4.5
	30.00	9.0	8.0	7.5	7.1	6.7
168	21.00	1.4	1.3	1.2	1.1	1.1
	31.50	2.7	2.5	2.3	2.2	2.1
	42.00	4.5	4.1	3.8	3.7	3.6
192	24.00	2.2	2.0	2.0	1.9	1.8
	36.00	4.8	4.4	4.2	4.0	3.9
	48.00	7.4	6.7	6.4	6.2	5.9
240	30.00	1.8	1.6	1.5	1.4	1.3
	45.00	4.2	3.6	3.4	3.2	3.1
	60.00	6.5	5.7	5.3	5.0	4.8
300	37.50	2.4	2.0	1.8	1.7	1.6
	56.25	5.4	4.5	4.0	3.8	3.6
	75.00	8.4	7.0	6.3	5.9	5.7

1. Based on 20% methanol antifreeze solution.

Models:  
MB  
072-300

## Unit Startup Procedure

**Table 14: Motorized Water Valve and Modulating Valve Adders**

Size	Flow	MWV					MOD Valve				
		C <sub>v</sub>	Close Off Pressure	MOPD	Pressure Drop		C <sub>v</sub>	Close Off Pressure	MOPD	Pressure Drop	
					PSI	FT				PSI	FT
072	9.00	37	200	50	0.06	0.1	10	200	50	0.81	1.9
	13.50				0.13	0.3				1.82	4.2
	18.00				0.24	0.5				3.24	7.5
096	12.00	37	200	50	0.11	0.2	10	200	50	1.44	3.3
	18.00				0.24	0.5				3.24	7.5
	24.00				0.42	1.0				5.76	13.3
120	15.00	37	200	150	0.16	0.4	19	200	50	0.62	1.4
	22.50				0.37	0.9				1.40	3.2
	30.00				0.66	1.5				2.49	5.8
168	21.00	37	200	150	0.32	0.7	29	200	50	0.52	1.2
	31.50				0.72	1.7				1.18	2.7
	42.00				1.29	3.0				2.10	4.8
192	24.00	37	200	150	0.42	1.0	29	200	50	0.68	1.6
	36.00				0.95	2.2				1.54	3.6
	48.00				1.68	3.9				2.74	6.3
240	30.00	37	200	150	0.66	1.5	29	200	50	1.07	2.5
	45.00				1.48	3.4				2.41	5.6
	60.00				2.63	6.1				4.28	9.9
300	37.50	57	200	150	0.43	1.0	29	200	50	1.67	3.9
	56.25				0.97	2.2				3.76	8.7
	75.00				1.73	4.0				6.69	15.4

- PSI values are calculated based on manufacturer-recommended 70°F entering water temperature.

# Unit Operating Conditions

Operating Pressure/Temperature tables include the following notes:

- Entering air is based upon 70°F (21°C) DB in heating and 80/67°F (27/19°C) in cooling
- Subcooling is based on head pressure reading taken at the compressor discharge service port and line temperature reading on the discharge line by the compressor discharge service port.
- Cooling air and water values can vary greatly with changes in humidity level
- For operation in the shaded area, when water is used in lieu of antifreeze, the LWT must be calculated. Flow must be maintained to a level such that the LWT is maintained above 42°F (5.6°C).

**Table 15: Typical Unit Operating Pressures and Temperatures**

MB 072	Entering Water Temp (°F)	Water Flow GPM/ton	CKT1		CKT1		CKT2		CKT2		Water Temp Rise (°F)	Air Temp Drop (°F) DB	Water Temp Drop (°F)"	Air Temp Rise (°F) DB
			Discharge Pressure CKT1 (PSIG)	Suction Pressure CKT1 (PSIG)	Superheat CKT1 (°F)	Subcooling CKT1 (°F)	Discharge Pressure CKT2 (PSIG)	Suction Pressure CKT2 (PSIG)	Superheat CKT2 (°F)	Subcooling CKT2 (°F)				
Full Load Cooling	30'	9	162 - 182	107 - 117	17 - 21	13 - 17	152 - 172	100 - 110	13 - 17	13 - 17	19 - 21	19 - 25		
		13.5	152 - 172	105 - 115	16 - 20	14 - 18	142 - 162	99 - 109	11 - 15	14 - 18	14 - 16	19 - 25		
		18	142 - 162	103 - 113	14 - 18	15 - 19	133 - 153	99 - 109	9 - 13	15 - 19	10 - 12	18 - 24		
	50	9	220 - 240	116 - 126	15 - 19	9 - 13	210 - 230	110 - 120	10 - 14	9 - 13	19 - 21	18 - 24		
		13.5	207 - 227	114 - 124	13 - 17	10 - 14	197 - 217	108 - 118	9 - 13	10 - 14	14 - 16	18 - 24		
		18	193 - 213	112 - 122	12 - 16	12 - 16	184 - 204	105 - 115	8 - 12	12 - 16	9 - 11	18 - 24		
	70	9	295 - 315	123 - 133	14 - 18	7 - 11	283 - 303	118 - 128	8 - 12	7 - 11	19 - 21	17 - 23		
		13.5	277 - 297	122 - 132	12 - 16	8 - 12	267 - 287	115 - 125	7 - 11	8 - 12	14 - 16	17 - 23		
		18	260 - 280	120 - 130	10 - 14	9 - 13	251 - 271	113 - 123	7 - 11	9 - 13	9 - 11	17 - 23		
	90	9	382 - 402	129 - 139	15 - 19	6 - 10	368 - 388	124 - 134	7 - 11	6 - 10	18 - 20	16 - 22		
		13.5	363 - 383	128 - 138	12 - 16	6 - 10	351 - 371	123 - 133	6 - 10	6 - 10	14 - 16	16 - 22		
		18	343 - 363	127 - 137	10 - 14	7 - 11	333 - 353	121 - 131	5 - 9	7 - 11	9 - 11	16 - 22		
120	9	535 - 555	136 - 146	17 - 21	5 - 9	518 - 538	133 - 143	6 - 10	5 - 9	18 - 20	14 - 20			
	13.5	515 - 535	135 - 145	15 - 19	5 - 9	500 - 520	132 - 142	5 - 9	5 - 9	13 - 15	14 - 20			
	18	495 - 515	134 - 144	13 - 17	5 - 9	482 - 502	130 - 140	4 - 8	5 - 9	8 - 10	15 - 21			
Full Load Heating	30'	9	265 - 285	60 - 70	8 - 12	6 - 10	259 - 279	60 - 70	8 - 12	6 - 10			8 - 10	18 - 24
		13.5	268 - 288	63 - 73	8 - 12	6 - 10	262 - 282	63 - 73	9 - 13	6 - 10			6 - 8	18 - 24
		18	271 - 291	66 - 76	8 - 12	6 - 10	265 - 285	66 - 76	9 - 13	6 - 10			4 - 6	19 - 25
	50	9	292 - 312	87 - 97	12 - 16	8 - 12	284 - 304	85 - 95	5 - 9	8 - 12			11 - 13	24 - 30
		13.5	296 - 316	90 - 100	12 - 16	9 - 13	288 - 308	89 - 99	6 - 10	9 - 13			8 - 10	25 - 31
		18	300 - 320	94 - 104	12 - 16	9 - 13	292 - 312	92 - 102	6 - 10	9 - 13			5 - 7	26 - 32
	70	9	318 - 338	112 - 122	12 - 16	11 - 15	309 - 329	110 - 120	5 - 9	11 - 15			14 - 16	30 - 36
		13.5	324 - 344	117 - 127	12 - 16	12 - 16	314 - 334	115 - 125	5 - 9	12 - 16			10 - 12	31 - 37
		18	329 - 349	123 - 133	13 - 17	12 - 16	319 - 339	119 - 129	5 - 9	12 - 16			7 - 9	32 - 38
	90	9	344 - 364	139 - 149	12 - 16	14 - 18	334 - 354	136 - 146	4 - 8	14 - 18			17 - 19	35 - 41
		13.5	351 - 371	146 - 156	12 - 16	16 - 20	340 - 360	142 - 152	4 - 8	16 - 20			13 - 15	36 - 42
		18	358 - 378	153 - 163	12 - 16	17 - 21	347 - 367	149 - 159	4 - 8	17 - 21			9 - 11	37 - 43
120	9													
	13.5													
	18													

1. Based on 20% methanol antifreeze solution.

Models:  
MB  
072-300

# Unit Operating Conditions

MB 0% MB 0%	Entering Water Temp (°F)	Water Flow GPM/ton	CKT1		CKT1		CKT2		CKT2		Water Temp Rise (°F)	Air Temp Drop (°F) DB	Water Temp Drop (°F)"	Air Temp Rise (°F) DB
			Discharge Pressure CKT1 (PSIG)	Suction Pressure CKT1 (PSIG)	Superheat CKT1 (°F)	Subcooling CKT1 (°F)	Discharge Pressure CKT2 (PSIG)	Suction Pressure CKT2 (PSIG)	Superheat CKT2 (°F)	Subcooling CKT2 (°F)				
Full Load Cooling	30'	12	167 - 187	106 - 116	16 - 20	12 - 16	161 - 181	106 - 116	5 - 9	12 - 16	20 - 22	20 - 26		
		18	155 - 175	104 - 114	14 - 18	13 - 17	150 - 170	104 - 114	3 - 7	13 - 17	15 - 17	20 - 26		
		24	144 - 164	101 - 111	11 - 15	13 - 17	139 - 159	101 - 111	1 - 5	13 - 17	10 - 12	20 - 26		
	50	12	217 - 237	115 - 125	15 - 19	9 - 13	210 - 230	113 - 123	11 - 15	9 - 13	21 - 23	19 - 25		
		18	202 - 222	112 - 122	13 - 17	10 - 14	197 - 217	111 - 121	9 - 13	10 - 14	15 - 17	19 - 25		
		24	188 - 208	110 - 120	12 - 16	11 - 15	183 - 203	109 - 119	7 - 11	11 - 15	10 - 12	19 - 25		
	70	12	284 - 304	122 - 132	15 - 19	8 - 12	276 - 296	120 - 130	11 - 15	8 - 12	21 - 23	18 - 24		
		18	266 - 286	120 - 130	13 - 17	8 - 12	260 - 280	118 - 128	9 - 13	8 - 12	15 - 17	18 - 24		
		24	249 - 269	118 - 128	11 - 15	9 - 13	244 - 264	117 - 127	7 - 11	9 - 13	10 - 12	18 - 24		
	90	12	367 - 387	128 - 138	15 - 19	6 - 10	357 - 377	126 - 136	10 - 14	6 - 10	20 - 22	17 - 23		
		18	347 - 367	126 - 136	12 - 16	6 - 10	339 - 359	125 - 135	8 - 12	6 - 10	15 - 17	17 - 23		
		24	327 - 347	125 - 135	10 - 14	7 - 11	321 - 341	124 - 134	6 - 10	7 - 11	10 - 12	17 - 23		
120	12	519 - 539	135 - 145	17 - 21	4 - 8	508 - 528	133 - 143	22 - 26	4 - 8	19 - 21	15 - 21			
	18	497 - 517	134 - 144	14 - 18	5 - 9	488 - 508	132 - 142	20 - 24	5 - 9	14 - 16	15 - 21			
	24	476 - 496	134 - 144	12 - 16	5 - 9	468 - 488	132 - 142	17 - 21	5 - 9	9 - 11	15 - 21			
Full Load Heating	30'	12	274 - 294	58 - 68	14 - 18	8 - 12	268 - 288	57 - 67	12 - 16	8 - 12			6 - 8	19 - 25
		18	272 - 292	57 - 67	13 - 17	8 - 12	267 - 287	55 - 65	11 - 15	8 - 12			7 - 9	19 - 25
		24	270 - 290	55 - 65	13 - 17	7 - 11	265 - 285	54 - 64	11 - 15	7 - 11			7 - 9	18 - 24
	50	12	299 - 319	80 - 90	16 - 20	9 - 13	293 - 313	79 - 89	14 - 18	9 - 13			11 - 13	25 - 31
		18	304 - 324	84 - 94	16 - 20	10 - 14	299 - 319	83 - 93	14 - 18	10 - 14			8 - 10	26 - 32
		24	309 - 329	89 - 99	16 - 20	10 - 14	304 - 324	88 - 98	14 - 18	10 - 14			6 - 8	27 - 33
	70	12	330 - 350	107 - 117	16 - 20	11 - 15	324 - 344	107 - 117	14 - 18	11 - 15			15 - 17	31 - 37
		18	337 - 357	114 - 124	16 - 20	11 - 15	331 - 351	114 - 124	14 - 18	11 - 15			11 - 13	32 - 38
		24	344 - 364	120 - 130	16 - 20	12 - 16	339 - 359	121 - 131	13 - 17	12 - 16			8 - 10	34 - 40
	90	12	364 - 384	139 - 149	14 - 18	13 - 17	358 - 378	140 - 150	11 - 15	13 - 17			19 - 21	38 - 44
		18	372 - 392	147 - 157	14 - 18	14 - 18	367 - 387	148 - 158	10 - 14	14 - 18			14 - 16	39 - 45
		24	381 - 401	155 - 165	13 - 17	15 - 19	375 - 395	157 - 167	9 - 13	15 - 19			10 - 12	41 - 47
120	12													
	18													
	24													

1. Based on 20% methanol antifreeze solution.

# Unit Operating Conditions

MB 120	Entering Water Temp (°F)	Water Flow GPM/ton	CKT1		CKT1		CKT2		CKT2		Water Temp Rise (°F)	Air Temp Drop (°F) DB	Water Temp Drop (°F)"	Air Temp Rise (°F) DB
			Discharge Pressure CKT1 (PSIG)	Suction Pressure CKT1 (PSIG)	Superheat CKT1 (°F)	Subcooling CKT1 (°F)	Discharge Pressure CKT2 (PSIG)	Suction Pressure CKT2 (PSIG)	Superheat CKT2 (°F)	Subcooling CKT2 (°F)				
Full Load Cooling	30'	15	184 - 204	93 - 103	34 - 38	18 - 22	188 - 208	91 - 101	32 - 36	18 - 22	23 - 25	17 - 23		
		22.5	163 - 183	86 - 96	29 - 33	25 - 29	167 - 187	82 - 92	16 - 20	25 - 29	16 - 18	15 - 21		
		30	141 - 161	78 - 88	25 - 29	31 - 35	145 - 165	73 - 83	0 - 4	31 - 35	9 - 11	14 - 20		
	50	15	226 - 246	107 - 117	22 - 26	13 - 17	229 - 249	106 - 116	20 - 24	13 - 17	21 - 23	18 - 24		
		22.5	209 - 229	100 - 110	21 - 25	18 - 22	212 - 232	101 - 111	15 - 19	18 - 22	15 - 17	17 - 23		
		30	193 - 213	93 - 103	20 - 24	23 - 27	195 - 215	96 - 106	9 - 13	23 - 27	9 - 11	16 - 22		
	70	15	290 - 310	115 - 125	18 - 22	9 - 13	293 - 313	115 - 125	16 - 20	9 - 13	20 - 22	17 - 23		
		22.5	274 - 294	111 - 121	17 - 21	12 - 16	276 - 296	113 - 123	14 - 18	12 - 16	15 - 17	17 - 23		
		30	257 - 277	106 - 116	16 - 20	15 - 19	259 - 279	110 - 120	12 - 16	15 - 19	9 - 11	17 - 23		
	90	15	374 - 394	120 - 130	19 - 23	6 - 10	379 - 399	121 - 131	16 - 20	6 - 10	20 - 22	16 - 22		
		22.5	355 - 375	118 - 128	16 - 20	7 - 11	358 - 378	120 - 130	14 - 18	7 - 11	15 - 17	16 - 22		
		30	335 - 355	117 - 127	14 - 18	9 - 13	338 - 358	119 - 129	12 - 16	9 - 13	9 - 11	16 - 22		
120	15	529 - 549	126 - 136	20 - 24	3 - 7	535 - 555	126 - 136	19 - 23	3 - 7	19 - 21	14 - 20			
	22.5	506 - 526	126 - 136	18 - 22	4 - 8	511 - 531	127 - 137	16 - 20	4 - 8	14 - 16	15 - 21			
	30	483 - 503	126 - 136	15 - 19	5 - 9	487 - 507	127 - 137	13 - 17	5 - 9	9 - 11	15 - 21			
Full Load Heating	30'	15	278 - 298	51 - 61	16 - 20	5 - 9	277 - 297	50 - 60	14 - 18	5 - 9			8 - 10	19 - 25
		22.5	281 - 301	54 - 64	17 - 21	5 - 9	281 - 301	53 - 63	14 - 18	5 - 9			6 - 8	20 - 26
		30	285 - 305	57 - 67	17 - 21	5 - 9	285 - 305	56 - 66	15 - 19	5 - 9			4 - 6	20 - 26
	50	15	313 - 333	78 - 88	18 - 22	4 - 8	312 - 332	76 - 86	15 - 19	4 - 8			11 - 13	26 - 32
		22.5	318 - 338	82 - 92	18 - 22	4 - 8	318 - 338	81 - 91	15 - 19	4 - 8			8 - 10	27 - 33
		30	324 - 344	86 - 96	17 - 21	4 - 8	324 - 344	85 - 95	15 - 19	4 - 8			5 - 7	28 - 34
	70	15	346 - 366	106 - 116	18 - 22	7 - 11	347 - 367	104 - 114	16 - 20	7 - 11			14 - 16	32 - 38
		22.5	355 - 375	113 - 123	17 - 21	7 - 11	355 - 375	111 - 121	15 - 19	7 - 11			11 - 13	34 - 40
		30	363 - 383	120 - 130	17 - 21	7 - 11	364 - 384	118 - 128	15 - 19	7 - 11			7 - 9	35 - 41
	90	15	385 - 405	140 - 150	16 - 20	10 - 14	385 - 405	137 - 147	14 - 18	10 - 14			18 - 20	39 - 45
		22.5	393 - 413	145 - 155	17 - 21	14 - 18	394 - 414	144 - 154	15 - 19	14 - 18			14 - 16	41 - 47
		30	401 - 421	151 - 161	18 - 22	17 - 21	402 - 422	151 - 161	15 - 19	17 - 21			9 - 11	42 - 48
120	15													
	22.5													
	30													

1. Based on 20% methanol antifreeze solution.

Models:  
MB  
072-300

# Unit Operating Conditions

MB 168	Entering Water Temp (°F)	Water Flow GPM/ton	CKT1		CKT1		CKT2		CKT2		Water Temp Rise (°F)	Air Temp Drop (°F) DB	Water Temp Drop (°F)"	Air Temp Rise (°F) DB
			Discharge Pressure CKT1 (PSIG)	Suction Pressure CKT1 (PSIG)	Superheat CKT1 (°F)	Subcooling CKT1 (°F)	Discharge Pressure CKT2 (PSIG)	Suction Pressure CKT2 (PSIG)	Superheat CKT2 (°F)	Subcooling CKT2 (°F)				
Full Load Cooling	30'	21	158 - 178	103 - 113	18 - 22	14 - 18	169 - 189	104 - 114	22 - 26	14 - 18	21 - 23	21 - 27		
		31.5	146 - 166	97 - 107	18 - 22	17 - 21	155 - 175	97 - 107	21 - 25	17 - 21	15 - 17	20 - 26		
		42	134 - 154	92 - 102	17 - 21	19 - 23	142 - 162	90 - 100	20 - 24	19 - 23	9 - 11	19 - 25		
	50	21	213 - 233	110 - 120	16 - 20	9 - 13	224 - 244	108 - 118	22 - 26	9 - 13	20 - 22	20 - 26		
		31.5	199 - 219	108 - 118	14 - 18	11 - 15	207 - 227	106 - 116	19 - 23	11 - 15	15 - 17	20 - 26		
		42	184 - 204	106 - 116	12 - 16	12 - 16	191 - 211	103 - 113	17 - 21	12 - 16	9 - 11	20 - 26		
	70	21	284 - 304	115 - 125	15 - 19	7 - 11	295 - 315	112 - 122	22 - 26	7 - 11	20 - 22	19 - 25		
		31.5	267 - 287	114 - 124	13 - 17	8 - 12	277 - 297	111 - 121	19 - 23	8 - 12	14 - 16	19 - 25		
		42	250 - 270	113 - 123	10 - 14	9 - 13	258 - 278	110 - 120	16 - 20	9 - 13	9 - 11	19 - 25		
	90	21	368 - 388	120 - 130	16 - 20	6 - 10	382 - 402	116 - 126	22 - 26	6 - 10	19 - 21	19 - 25		
		31.5	350 - 370	119 - 129	13 - 17	7 - 11	361 - 381	115 - 125	19 - 23	7 - 11	14 - 16	19 - 25		
		42	331 - 351	118 - 128	11 - 15	7 - 11	341 - 361	115 - 125	16 - 20	7 - 11	9 - 11	19 - 25		
120	21	520 - 540	126 - 136	16 - 20	5 - 9	534 - 554	124 - 134	21 - 25	5 - 9	18 - 20	17 - 23			
	31.5	499 - 519	126 - 136	14 - 18	5 - 9	512 - 532	123 - 133	18 - 22	5 - 9	13 - 15	17 - 23			
	42	479 - 499	125 - 135	12 - 16	6 - 10	489 - 509	123 - 133	16 - 20	6 - 10	9 - 11	17 - 23			
Full Load Heating	30'	21	284 - 304	55 - 65	10 - 14	13 - 17	282 - 302	54 - 64	9 - 13	13 - 17			3 - 5	18 - 24
		31.5	279 - 299	52 - 62	9 - 13	13 - 17	277 - 297	51 - 61	8 - 12	13 - 17			5 - 7	17 - 23
		42	274 - 294	48 - 58	8 - 12	13 - 17	272 - 292	47 - 57	7 - 11	13 - 17			6 - 8	16 - 22
	50	21	310 - 330	74 - 84	13 - 17	13 - 17	306 - 326	71 - 81	13 - 17	13 - 17			9 - 11	23 - 29
		31.5	316 - 336	78 - 88	13 - 17	13 - 17	312 - 332	75 - 85	14 - 18	13 - 17			7 - 9	24 - 30
		42	321 - 341	83 - 93	14 - 18	14 - 18	318 - 338	80 - 90	14 - 18	14 - 18			5 - 7	25 - 31
	70	21	344 - 364	101 - 111	15 - 19	15 - 19	340 - 360	96 - 106	16 - 20	15 - 19			13 - 15	29 - 35
		31.5	350 - 370	107 - 117	15 - 19	15 - 19	346 - 366	102 - 112	16 - 20	15 - 19			10 - 12	30 - 36
		42	357 - 377	113 - 123	15 - 19	16 - 20	353 - 373	108 - 118	17 - 21	16 - 20			7 - 9	31 - 37
	90	21	380 - 400	133 - 143	14 - 18	17 - 21	374 - 394	126 - 136	16 - 20	17 - 21			17 - 19	35 - 41
		31.5	388 - 408	139 - 149	14 - 18	18 - 22	382 - 402	132 - 142	16 - 20	18 - 22			12 - 14	36 - 42
		42	396 - 416	146 - 156	14 - 18	19 - 23	390 - 410	139 - 149	16 - 20	19 - 23			8 - 10	37 - 43
120	21													
	31.5													
	42													

1. Based on 20% methanol antifreeze solution.

Models:  
MB  
072-300

# Unit Operating Conditions

MB 192	Entering Water Temp (°F)	Water Flow GPM/ton	CKT1		CKT1		CKT2		CKT2		Water Temp Rise (°F)	Air Temp Drop (°F) DB	Water Temp Drop (°F)"	Air Temp Rise (°F) DB
			Discharge Pressure CKT1 (PSIG)	Suction Pressure CKT1 (PSIG)	Superheat CKT1 (°F)	Subcooling CKT1 (°F)	Discharge Pressure CKT2 (PSIG)	Suction Pressure CKT2 (PSIG)	Superheat CKT2 (°F)	Subcooling CKT2 (°F)				
Full Load Cooling	30'	24	173 - 193	104 - 114	20 - 24	11 - 15	179 - 199	103 - 113	21 - 25	11 - 15	23 - 25	20 - 26		
		36	151 - 171	101 - 111	15 - 19	14 - 18	156 - 176	100 - 110	16 - 20	14 - 18	16 - 18	20 - 26		
		48	129 - 149	97 - 107	10 - 14	16 - 20	132 - 152	97 - 107	10 - 14	16 - 20	9 - 11	19 - 25		
	50	24	208 - 228	112 - 122	16 - 20	8 - 12	213 - 233	111 - 121	17 - 21	8 - 12	20 - 22	20 - 26		
		36	195 - 215	110 - 120	14 - 18	10 - 14	199 - 219	109 - 119	15 - 19	10 - 14	15 - 17	20 - 26		
		48	182 - 202	107 - 117	12 - 16	11 - 15	185 - 205	106 - 116	13 - 17	11 - 15	9 - 11	20 - 26		
	70	24	268 - 288	118 - 128	15 - 19	7 - 11	273 - 293	117 - 127	17 - 21	7 - 11	19 - 21	19 - 25		
		36	256 - 276	116 - 126	14 - 18	7 - 11	260 - 280	115 - 125	16 - 20	7 - 11	14 - 16	19 - 25		
		48	243 - 263	114 - 124	13 - 17	8 - 12	247 - 267	113 - 123	14 - 18	8 - 12	9 - 11	19 - 25		
	90	24	348 - 368	122 - 132	17 - 21	6 - 10	353 - 373	121 - 131	19 - 23	6 - 10	18 - 20	19 - 25		
		36	333 - 353	121 - 131	15 - 19	6 - 10	337 - 357	119 - 129	17 - 21	6 - 10	13 - 15	19 - 25		
		48	318 - 338	119 - 129	13 - 17	7 - 11	320 - 340	118 - 128	14 - 18	7 - 11	9 - 11	19 - 25		
120	24	496 - 516	129 - 139	18 - 22	5 - 9	499 - 519	128 - 138	19 - 23	5 - 9	17 - 19	17 - 23			
	36	478 - 498	128 - 138	16 - 20	6 - 10	480 - 500	127 - 137	17 - 21	6 - 10	12 - 14	17 - 23			
	48	461 - 481	127 - 137	14 - 18	6 - 10	461 - 481	126 - 136	15 - 19	6 - 10	8 - 10	17 - 23			
Full Load Heating	30'	24	254 - 274	51 - 61	9 - 13	8 - 12	252 - 272	53 - 63	5 - 9	8 - 12			7 - 9	16 - 22
		36	257 - 277	54 - 64	9 - 13	8 - 12	255 - 275	56 - 66	5 - 9	8 - 12			5 - 7	17 - 23
		48	261 - 281	57 - 67	10 - 14	7 - 11	258 - 278	59 - 69	5 - 9	7 - 11			3 - 5	18 - 24
	50	24	283 - 303	78 - 88	12 - 16	10 - 14	279 - 299	77 - 87	8 - 12	10 - 14			10 - 12	22 - 28
		36	287 - 307	82 - 92	13 - 17	10 - 14	283 - 303	81 - 91	8 - 12	10 - 14			7 - 9	23 - 29
		48	292 - 312	87 - 97	13 - 17	10 - 14	287 - 307	85 - 95	8 - 12	10 - 14			5 - 7	24 - 30
	70	24	311 - 331	107 - 117	12 - 16	10 - 14	306 - 326	104 - 114	8 - 12	10 - 14			13 - 15	28 - 34
		36	317 - 337	114 - 124	11 - 15	11 - 15	311 - 331	110 - 120	8 - 12	11 - 15			10 - 12	29 - 35
		48	323 - 343	121 - 131	10 - 14	11 - 15	317 - 337	116 - 126	7 - 11	11 - 15			7 - 9	31 - 37
	90	24	341 - 361	141 - 151	9 - 13	13 - 17	334 - 354	135 - 145	5 - 9	13 - 17			17 - 19	34 - 40
		36	347 - 367	147 - 157	8 - 12	14 - 18	340 - 360	142 - 152	4 - 8	14 - 18			13 - 15	35 - 41
		48	353 - 373	154 - 164	8 - 12	15 - 19	345 - 365	149 - 159	4 - 8	15 - 19			9 - 11	36 - 42
120	24													
	36													
	48													

1. Based on 20% methanol antifreeze solution.

Models:  
MB  
072-300

# Unit Operating Conditions

MB 240	Entering Water Temp (°F)	Water Flow GPM/ton	CKT1		CKT1		CKT2		CKT2		Water Temp Rise (°F)	Air Temp Drop (°F) DB	Water Temp Drop (°F)"	Air Temp Rise (°F) DB
			Discharge Pressure CKT1 (PSIG)	Suction Pressure CKT1 (PSIG)	Superheat CKT1 (°F)	Subcooling CKT1 (°F)	Discharge Pressure CKT2 (PSIG)	Suction Pressure CKT2 (PSIG)	Superheat CKT2 (°F)	Subcooling CKT2 (°F)				
Full Load Cooling	30'	30	181 - 201	105 - 115	18 - 22	12 - 16	191 - 211	108 - 118	19 - 23	12 - 16	22 - 24	19 - 25		
		45	158 - 178	97 - 107	16 - 20	17 - 21	165 - 185	100 - 110	17 - 21	17 - 21	15 - 17	19 - 25		
		60	136 - 156	89 - 99	13 - 17	22 - 26	139 - 159	92 - 102	15 - 19	22 - 26	9 - 11	18 - 24		
	50	30	218 - 238	112 - 122	16 - 20	9 - 13	227 - 247	113 - 123	16 - 20	9 - 13	20 - 22	19 - 25		
		45	205 - 225	110 - 120	14 - 18	11 - 15	211 - 231	111 - 121	15 - 19	11 - 15	15 - 17	19 - 25		
		60	191 - 211	107 - 117	12 - 16	12 - 16	195 - 215	109 - 119	13 - 17	12 - 16	9 - 11	19 - 25		
	70	30	280 - 300	117 - 127	15 - 19	7 - 11	289 - 309	117 - 127	15 - 19	7 - 11	19 - 21	18 - 24		
		45	265 - 285	116 - 126	13 - 17	8 - 12	271 - 291	116 - 126	13 - 17	8 - 12	14 - 16	18 - 24		
		60	250 - 270	115 - 125	10 - 14	8 - 12	254 - 274	115 - 125	10 - 14	8 - 12	9 - 11	18 - 24		
	90	30	363 - 383	121 - 131	16 - 20	5 - 9	372 - 392	121 - 131	15 - 19	5 - 9	18 - 20	17 - 23		
		45	342 - 362	119 - 129	13 - 17	6 - 10	348 - 368	119 - 129	12 - 16	6 - 10	13 - 15	17 - 23		
		60	321 - 341	118 - 128	10 - 14	7 - 11	325 - 345	118 - 128	8 - 12	7 - 11	8 - 10	17 - 23		
120	30	516 - 536	127 - 137	18 - 22	5 - 9	523 - 543	128 - 138	15 - 19	5 - 9	17 - 19	16 - 22			
	45	497 - 517	126 - 136	15 - 19	5 - 9	502 - 522	127 - 137	13 - 17	5 - 9	13 - 15	16 - 22			
	60	477 - 497	126 - 136	13 - 17	5 - 9	480 - 500	127 - 137	10 - 14	5 - 9	8 - 10	16 - 22			
Full Load Heating	30'	30	260 - 280	60 - 70	16 - 20	7 - 11	270 - 290	56 - 66	17 - 21	7 - 11			3 - 5	17 - 23
		45	262 - 282	54 - 64	16 - 20	8 - 12	267 - 287	51 - 61	17 - 21	8 - 12			5 - 7	17 - 23
		60	263 - 283	48 - 58	17 - 21	9 - 13	263 - 283	47 - 57	16 - 20	9 - 13			7 - 9	16 - 22
	50	30	289 - 309	94 - 104	17 - 21	7 - 11	303 - 323	85 - 95	19 - 23	7 - 11			4 - 6	23 - 29
		45	294 - 314	85 - 95	19 - 23	8 - 12	301 - 321	80 - 90	19 - 23	8 - 12			7 - 9	23 - 29
		60	299 - 319	75 - 85	20 - 24	8 - 12	298 - 318	74 - 84	19 - 23	8 - 12			10 - 12	23 - 29
	70	30	352 - 372	119 - 129	21 - 25	10 - 14	349 - 369	117 - 127	19 - 23	10 - 14			7 - 9	33 - 39
		45	343 - 363	111 - 121	21 - 25	10 - 14	340 - 360	109 - 119	19 - 23	10 - 14			10 - 12	31 - 37
		60	335 - 355	104 - 114	21 - 25	9 - 13	332 - 352	102 - 112	20 - 24	9 - 13			13 - 15	30 - 36
	90	30	395 - 415	155 - 165	19 - 23	14 - 18	392 - 412	154 - 164	16 - 20	14 - 18			9 - 11	41 - 47
		45	385 - 405	146 - 156	19 - 23	12 - 16	381 - 401	144 - 154	17 - 21	12 - 16			13 - 15	39 - 45
		60	374 - 394	138 - 148	20 - 24	11 - 15	371 - 391	134 - 144	18 - 22	11 - 15			17 - 19	37 - 43
120	30													
	45													
	60													

1. Based on 20% methanol antifreeze solution.

Models:  
MB  
072-300

# Unit Operating Conditions

MB 300	Entering Water Temp (°F)	Water Flow GPM/ton	CKT1		CKT1		CKT2		CKT2		Water Temp Rise (°F)	Air Temp Drop (°F) DB	Water Temp Drop (°F)''	Air Temp Rise (°F) DB
			Discharge Pressure CKT1 (PSIG)	Suction Pressure CKT1 (PSIG)	Superheat CKT1 (°F)	Subcooling CKT1 (°F)	Discharge Pressure CKT2 (PSIG)	Suction Pressure CKT2 (PSIG)	Superheat CKT2 (°F)	Subcooling CKT2 (°F)				
Full Load Cooling	30'	37.5	171 - 191	112 - 122	4 - 8	4 - 8	178 - 198	113 - 123	14 - 18	4 - 8	21 - 23	19 - 25		
		56.25	166 - 186	113 - 123	4 - 8	5 - 9	171 - 191	115 - 125	10 - 14	5 - 9	16 - 18	19 - 25		
		75	161 - 181	114 - 124	4 - 8	6 - 10	164 - 184	117 - 127	6 - 10	6 - 10	12 - 14	19 - 25		
	50	37.5	216 - 236	114 - 124	5 - 9	4 - 8	225 - 245	116 - 126	14 - 18	4 - 8	20 - 22	19 - 25		
		56.25	205 - 225	114 - 124	3 - 7	4 - 8	212 - 232	116 - 126	11 - 15	4 - 8	15 - 17	19 - 25		
		75	194 - 214	114 - 124	2 - 6	5 - 9	199 - 219	116 - 126	7 - 11	5 - 9	10 - 12	19 - 25		
	70	37.5	280 - 300	118 - 128	7 - 11	3 - 7	291 - 311	120 - 130	15 - 19	3 - 7	20 - 22	18 - 24		
		56.25	265 - 285	117 - 127	4 - 8	4 - 8	274 - 294	119 - 129	12 - 16	4 - 8	15 - 17	18 - 24		
		75	250 - 270	117 - 127	2 - 6	4 - 8	257 - 277	119 - 129	9 - 13	4 - 8	9 - 11	18 - 24		
	90	37.5	361 - 381	122 - 132	8 - 12	3 - 7	374 - 394	124 - 134	15 - 19	3 - 7	19 - 21	17 - 23		
		56.25	344 - 364	121 - 131	6 - 10	3 - 7	355 - 375	123 - 133	12 - 16	3 - 7	14 - 16	17 - 23		
		75	326 - 346	120 - 130	3 - 7	3 - 7	335 - 355	123 - 133	9 - 13	3 - 7	9 - 11	17 - 23		
120	37.5	508 - 528	129 - 139	9 - 13	2 - 6	525 - 545	131 - 141	15 - 19	2 - 6	18 - 20	15 - 21			
	56.25	489 - 509	128 - 138	7 - 11	2 - 6	503 - 523	130 - 140	12 - 16	2 - 6	13 - 15	15 - 21			
	75	471 - 491	128 - 138	5 - 9	2 - 6	482 - 502	130 - 140	10 - 14	2 - 6	9 - 11	16 - 22			
Full Load Heating	30'	37.5	266 - 286	48 - 58	6 - 10	7 - 11	267 - 287	47 - 57	7 - 11	7 - 11			6 - 8	16 - 22
		56.25	271 - 291	52 - 62	7 - 11	7 - 11	271 - 291	51 - 61	7 - 11	7 - 11			5 - 7	17 - 23
		75	275 - 295	55 - 65	7 - 11	7 - 11	275 - 295	54 - 64	8 - 12	7 - 11			3 - 5	18 - 24
	50	37.5	301 - 321	74 - 84	11 - 15	6 - 10	301 - 321	74 - 84	13 - 17	6 - 10			10 - 12	23 - 29
		56.25	306 - 326	78 - 88	11 - 15	6 - 10	307 - 327	79 - 89	14 - 18	6 - 10			7 - 9	24 - 30
		75	311 - 331	83 - 93	12 - 16	6 - 10	313 - 333	83 - 93	15 - 19	6 - 10			5 - 7	25 - 31
	70	37.5	337 - 357	104 - 114	14 - 18	7 - 11	338 - 358	102 - 112	17 - 21	7 - 11			14 - 16	30 - 36
		56.25	345 - 365	111 - 121	13 - 17	7 - 11	346 - 366	109 - 119	17 - 21	7 - 11			10 - 12	32 - 38
		75	353 - 373	118 - 128	13 - 17	7 - 11	355 - 375	116 - 126	17 - 21	7 - 11			7 - 9	33 - 39
	90	37.5	376 - 396	138 - 148	11 - 15	8 - 12	379 - 399	135 - 145	17 - 21	8 - 12			18 - 20	37 - 43
		56.25	387 - 407	148 - 158	10 - 14	9 - 13	388 - 408	145 - 155	16 - 20	9 - 13			13 - 15	39 - 45
		75	398 - 418	159 - 169	9 - 13	9 - 13	398 - 418	155 - 165	15 - 19	9 - 13			9 - 11	41 - 47
120	37.5													
	56.25													
	75													

1. Based on 20% methanol antifreeze solution.

Models:  
MB  
072-300

# Startup Log Sheet

**Installer:** Complete *Unit and System Checkout* and follow *Unit Startup Procedures* in the IOM. Use this form to record unit information, temperatures, and pressures during startup. Keep this form for reference.

**Job Name:** \_\_\_\_\_

**Street Address:** \_\_\_\_\_

**Model Number:** \_\_\_\_\_ **Serial Number:** \_\_\_\_\_

**Unit Location in Building:** \_\_\_\_\_

**Date:** \_\_\_\_\_ **Sales Order Number:** \_\_\_\_\_

In order to minimize troubleshooting and costly system failures, complete the following checks and data entries before the system is put into full operation.

External Static: \_\_\_\_\_

Sheave Setting: \_\_\_\_\_ Turns Open

Temperatures (check one):  °F  °C Antifreeze: \_\_\_\_\_ %

Pressures (check one):  PSIG  kPa Type: \_\_\_\_\_

	Cooling Mode		Heating Mode
Entering Fluid Temperature			
Leaving Fluid Temperature			
<b>Fluid Temperature Differential</b>			
Return-Air Temperature	DB	WB	DB
Supply-Air Temperature	DB	WB	DB
<b>Air Temperature Differential</b>			
Water Coil Heat Exchanger (Water Pressure IN)			
Water Coil Heat Exchanger (Water Pressure OUT)			
Pressure Differential			
Flow Rate GPM (l/s)			
<b>Compressor</b>			
Amps			
Volts			
Discharge Line Temperature			
<b>Motor</b>			
Amps			
Volts			

**NOTES:**

1. Allow unit to run 15 minutes in each mode before taking data.
2. Never connect refrigerant gauges during startup procedures.
3. Conduct water-side analysis using P/T ports to determine water flow and temperature difference.
4. If water-side analysis shows poor performance, refrigerant troubleshooting may be required.
5. Connect refrigerant gauges as a last resort.

## Preventative Maintenance

### WATER COIL MAINTENANCE (WATER LOOP APPLICATIONS)

Generally water coil maintenance is not needed for closed loop systems. However, if the piping is known to have high dirt or debris content, it is best to establish a periodic maintenance schedule with the owner so the water coil can be checked regularly. Dirty installations are typically the result of deterioration of iron or galvanized piping or components in the system. Open cooling towers requiring heavy chemical treatment and mineral buildup through water use can also contribute to higher maintenance. Should periodic coil cleaning be necessary, use standard coil cleaning procedures, which are compatible with both the heat exchanger material and copper water lines. Generally, the more water flowing through the unit, the less chance for scaling. However, flow rates over 3 gpm per ton (3.9 l/m per kW) can produce water (or debris) velocities that can erode the heat exchanger wall and ultimately produce leaks.

### HOT WATER GENERATOR COILS

See water coil maintenance for ground water units. If the potable water is hard or not chemically softened, the high temperatures of the desuperheater will tend to scale even quicker than the water coil and may need more frequent inspections. In areas with extremely hard water, a HWG is not recommended.

### FILTERS

Filters must be clean to obtain maximum performance. Filters should be inspected every month under normal operating conditions and be replaced when necessary. Units should never be operated without a filter.

### CONDENSATE DRAIN

In areas where airborne bacteria may produce a "slimy" substance in the drain pan, it may be necessary to treat the drain pan chemically with an algacide approximately every three months to minimize the problem. The condensate pan may also need to be cleaned periodically to ensure indoor air quality. The condensate drain can pick up lint and dirt, especially with dirty filters. Inspect the drain twice a year to avoid the possibility of plugging and eventual overflow.

### COMPRESSOR

Conduct annual amperage checks to ensure that amp draw is no more than 10% greater than indicated on the serial dataplate.

### AIR COIL

The air coil must be cleaned to obtain maximum performance. Check once a year under normal operating conditions and, if dirty, brush or vacuum clean. Care must be taken not to damage the aluminum fins while cleaning.

#### CAUTION

Fin edges are sharp and may cause injury.

### BELT

Ensure the belt is tight. Retighten if needed. Replace if it is split or cracked.

### CABINET

Do not allow water to stay in contact with the cabinet for long periods of time to prevent corrosion of the cabinet sheet metal. Generally, vertical cabinets are set up from the floor a few inches (7 - 8 cm) to prevent water from entering the cabinet. The cabinet can be cleaned using a mild detergent.







### REPAIRS TO SEALED COMPONENTS

Sealed electrical components shall be replaced.

Models:  
MB  
072-300

# Circuit Diagram with Safety Devices

**SYMBOL LEGEND**

-  = TEMPERATURE SENSOR
-  = PRESSURE SWITCH
-  = REFRIGERANT FLOW COOLING MODE
-  = REFRIGERANT FLOW HEATING MODE
-  = REFRIGERANT FLOW EITHER MODE
-  = WATER FLOW

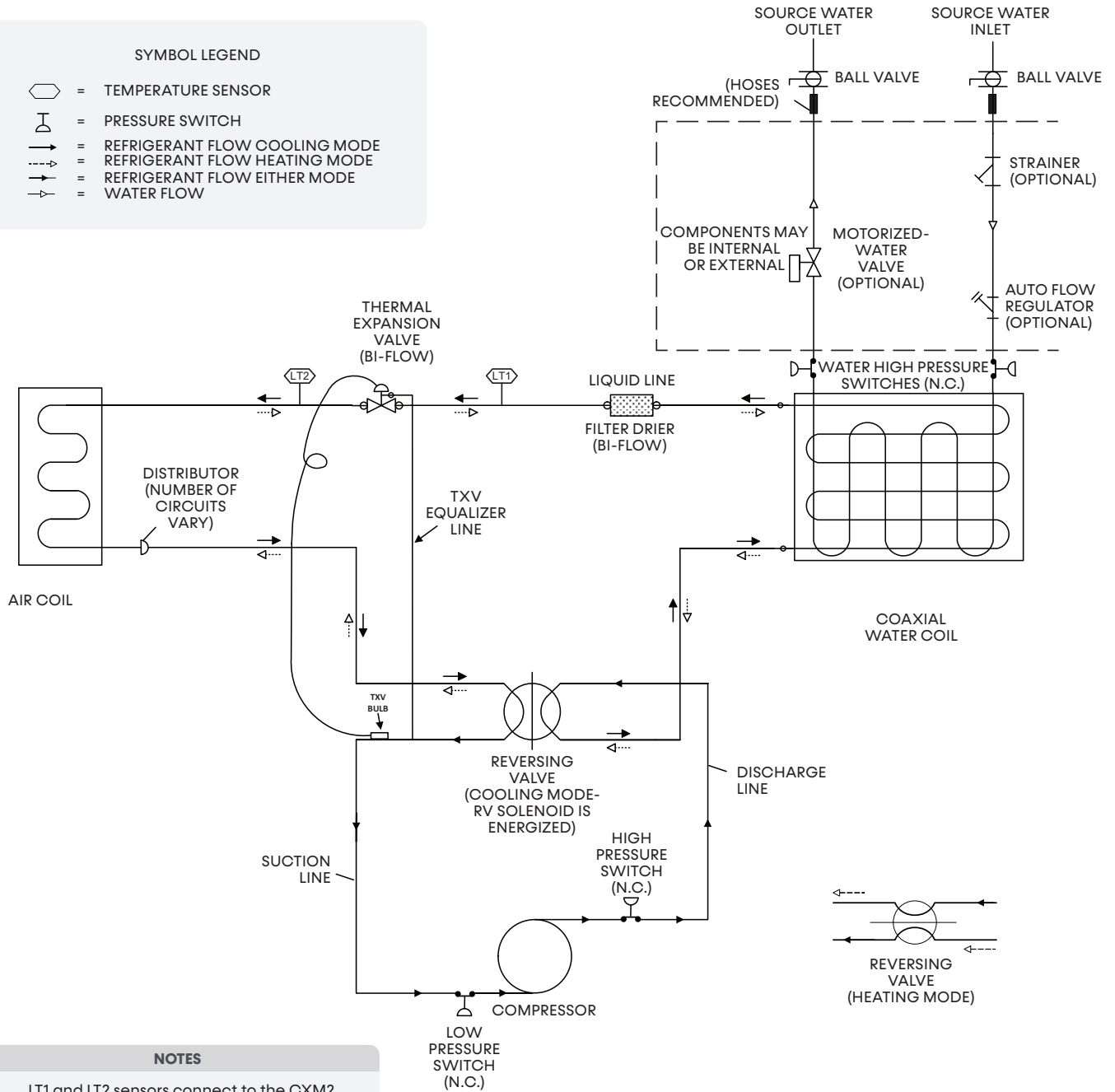

**NOTES**

1. LT1 and LT2 sensors connect to the CXM2
2. Refrigerant high and low pressure switches connect to the CXM2
3. Water high-pressure switches are wired in series with refrigerant high-pressure switch.

# Troubleshooting Troubleshooting Table

Models:  
MB  
072-300

Fault LED/Fault/Symptom	HT	CL	Possible Cause	Solution
<b>Main power problems</b>	X	X	Green Status LED off	<ul style="list-style-type: none"> <li>• Check the line voltage circuit breaker and disconnect.</li> <li>• Check for line voltage between L1 and L2 on the contactor.</li> <li>• Check for 24VAC between R and C on the unit control.</li> <li>• Check primary/secondary voltage on transformer.</li> </ul>
<b>Flash Code 2 HP Fault High Pressure</b>		X	Reduced or no water flow in cooling	<ul style="list-style-type: none"> <li>• Check pump operation or valve operation/setting.</li> <li>• Check water flow adjust to proper flow rate.</li> </ul>
		X	Water temperature out of range in cooling	Bring water temp within design parameters.
	X		Reduced or no airflow in heating	<ul style="list-style-type: none"> <li>• Check for dirty air filter and clean or replace.</li> <li>• Check fan motor operation and airflow restrictions.</li> <li>• Dirty air coil. Clean out construction dust etc.</li> <li>• Too high of external static? Check static vs blower table.</li> </ul>
	X		Air temperature out of range in heating	Bring return air temp within design parameters.
	X	X	Non-condensables in system	Vacuum system and re-weigh in charge.
	X	X	Restricted metering device	Check superheat and subcooling per chart. Replace.
	X	X	Unit overcharged	Check superheat/subcooling vs typical operating condition table.
	X	X	Bad HP switch	Check switch continuity and operation. Replace.
<b>Flash Code 3 LP/LOC Fault Low Pressure Loss of Charge</b>	X	X	Insufficient charge	Check for refrigerant leaks.
	X	X	Bad LP switch	Check switch continuity and operation. Replace
	X		Reduced water flow in heating	<ul style="list-style-type: none"> <li>• Check pump operation or water valve operation/setting.</li> <li>• Plugged strainer or filter? Clean or replace.</li> <li>• Check water flow. Adjust to proper flow rate.</li> </ul>
	X		Water temperature out of range	Bring water temperature within design parameters.
		X	Reduced airflow in cooling	<ul style="list-style-type: none"> <li>• Check for dirty air filter then clean or replace.</li> <li>• Check fan motor operation and airflow restrictions.</li> <li>• Is external static too high? Check static against blower table.</li> </ul>
		X	Air temperature out of range	Is there too much cold vent air? Bring air temperature within design parameters.
	X		Compressor pump down at startup	Check charge and startup water flow.
<b>Flash Code 4 LT1 Fault Water Coil Low Temperature Limit</b>	X		Reduced or no water flow in heating	<ul style="list-style-type: none"> <li>• Check pump operation or water valve operation/setting.</li> <li>• Plugged strainer or filter? Clean or replace.</li> <li>• Check water flow. Adjust to proper flow rate.</li> </ul>
	X		Inadequate antifreeze level	Check antifreeze density with hydrometer.
	X		Improper temperature limit setting (30°F vs 10°F [-1°C vs -2°C])	Clip JW3 jumper for antifreeze (10°F [-12°C]) use.
	X		Water temperature out of range	Bring water temp within design parameters.
	X	X	Bad thermistor	Check temp and impedance correlation per chart.
<b>Flash Code 5 LT2 Fault Air Coil Low Temperature Limit</b>		X	Reduced or no airflow in cooling	<ul style="list-style-type: none"> <li>• Check for dirty air filter and clean or replace.</li> <li>• Check fan motor operation and airflow restrictions.</li> <li>• Too high of external static? Check static against blower table.</li> </ul>
		X	Air temperature out of range	Too much cold vent air? Bring entering air temp within design parameters.
		X	Improper temperature limit setting (30°F vs 10°F [-1°C vs -12°C])	Normal air side applications require 30°F (-1°C) only.
	X	X	Bad thermistor	Check temp and impedance correlation per chart.

Table continued on next page.

Models:  
MB  
072-300

# Troubleshooting Troubleshooting Table

Table continued from previous page.

Fault LED/Fault/Symptom	HT	CL	Possible Cause	Solution
<b>Flash Code 6</b> <b>Condensate Fault</b>	X	X	Blocked drain	Check for blockage and clean drain.
	X	X	Improper trap	Check trap dimensions and location ahead of vent.
		X	Poor drainage	<ul style="list-style-type: none"> <li>Check for piping slope away from unit.</li> <li>Check slope of unit toward outlet.</li> <li>Poor venting? Check vent location.</li> </ul>
		X	Moisture on sensor	Check for moisture shorting to air coil.
	X	X	Plugged air filter	Replace air filter.
	X	X	Restricted return airflow	Find and eliminate restriction. Increase return duct and/or grille size.
<b>Flash Code 7</b> <b>Over/Under Voltage (Auto Resetting)</b>	X	X	Under voltage	<ul style="list-style-type: none"> <li>Check power supply and 24VAC voltage before and during operation.</li> <li>Check power supply wire size.</li> <li>Check compressor starting. Need hard start kit?</li> <li>Check 24VAC and unit transformer. Tap for correct power supply voltage.</li> </ul>
	X	X	Over voltage	<ul style="list-style-type: none"> <li>Check power supply voltage and 24VAC before and during operation.</li> <li>Check 24VAC and unit transformer. Tap for correct power supply voltage.</li> </ul>
<b>Flash Code 8</b> <b>Unit Performance Sentinel</b>	X		Heating mode LT2>125°F (52°C)	Check for poor airflow or overcharged unit.
		X	Cooling Mode LT1>125°F (52°C) OR LT2< 40°F (4°C)	Check for poor water flow or airflow.
<b>Flash Code 9</b> <b>Swapped Thermistor</b>	X	X	LT1 and LT2 swapped	Reverse position of thermistors
<b>Flash Code 13</b> <b>Low Water Flow</b>	X	X	Reduced or no water flow	<ul style="list-style-type: none"> <li>Check pump or valve operation setting.</li> <li>Check water flow and adjust to proper flow rate.</li> <li>Clogged Y strainer, replace mesh.</li> </ul>
	X		Inadequate antifreeze level	Check antifreeze density with hydrometer.
	X	X	Bad flow switch	Confirm applied flow to looks vs minimum flow switch setpoint on label.
<b>Flash Code 14</b> <b>Leaving Water Temperature Low</b>	X		Reduced or no water flow in heating	<ul style="list-style-type: none"> <li>Check pump or valve operation setting.</li> <li>Check water flow and adjust to proper flow rate.</li> </ul>
	X		Inadequate antifreeze level	Check antifreeze density with hydrometer.
	X		Improper temperature limit setting (30°F vs 15°F [-1°C vs -9°C])	Clip JW3 jumper for antifreeze (15°F [-9°C]) use.
	X		Water temperature out of range	Bring water temperature within design parameters.
	X	X	Bad thermistor	Check temperature impedance correlation per chart.
<b>Flash Code 15</b> <b>Refrigerant and RDS</b>	X	X	Refrigerant leak	Check the refrigerant charge. If the charge is low, identify and repair the leak.
		X	Faulty RDS sensor	Check the refrigerant charge. If the charge is not low, replace the RDS sensor.
<b>No Fault Code Shown</b>	X	X	No compressor operation	See the <i>Only Fan Runs</i> symptom.
	X	X	Compressor overload	Check and replace, if necessary.
	X	X	Control board	Reset power and check operation.

Table continued on next page.

# Troubleshooting Troubleshooting Table

Models:  
MB  
072-300

Table continued from previous page.

Fault LED/Fault/Symptom	HT	CL	Possible Cause	Solution
Unit Short Cycles	X	X	Dirty air filter	Check and clean air filter.
	X	X	Unit in Test mode	Reset power or wait 30 minutes for auto exit.
	X	X	Unit selection	Unit may be oversized for space. Check sizing for actual load of space.
	X	X	Compressor overload	Check and replace, if necessary.
Only Fan Runs	X	X	Thermostat position	Ensure thermostat set for heating or cooling operation.
	X	X	Unit locked out	Check for lockout codes. Reset power.
	X	X	Compressor overload	Check compressor overload. Replace if necessary.
	X	X	Thermostat wiring	Check thermostat wiring at heat pump. Jumper Y and R for compressor operation in test mode.
Only Compressor Runs	X	X	Thermostat wiring	<ul style="list-style-type: none"> <li>• Check G wiring at heat pump. Jumper G and R for fan operation.</li> <li>• Check thermostat wiring at heat pump. Jumper Y and R for compressor operation in test mode.</li> </ul>
	X	X		
	X	X	Fan motor relay	<ul style="list-style-type: none"> <li>• Jumper G and R for fan operation. Check for line voltage across BR contacts.</li> <li>• Check fan power enable relay operation (if present).</li> </ul>
	X	X		
	X	X	Fan motor	Check for line voltage at motor. Check capacitor.
Unit Doesn't Operate in Cooling		X	Reversing valve	Set for cooling demand and check 24VAC on RV coil and at the unit control.
		X		If RV is stuck, increase high pressure by reducing water flow and while operating engage and disengage RV coil voltage to push valve.
		X	Thermostat setup	Check for 'O' RV setup not 'B'.
		X	Thermostat wiring	Check O wiring at heat pump. Jumper O and R for RV coil 'click'.
		X		Put thermostat in cooling mode. Check 24VAC on O (check between C and O); check for 24VAC on W (check between W and C). There should be voltage on O, but not on W. If voltage is present on W, the thermostat may be bad or wired incorrectly.

Models:  
MB  
072-300

# Troubleshooting Functional Troubleshooting Form

**Customer:** \_\_\_\_\_

**Street Address:** \_\_\_\_\_

**Model Number:** \_\_\_\_\_ **Serial Number:** \_\_\_\_\_

**Loop Type:** \_\_\_\_\_ **Antifreeze:** \_\_\_\_\_

**Complaint:** \_\_\_\_\_ **Date:** \_\_\_\_\_

### Heating Cycle Analysis

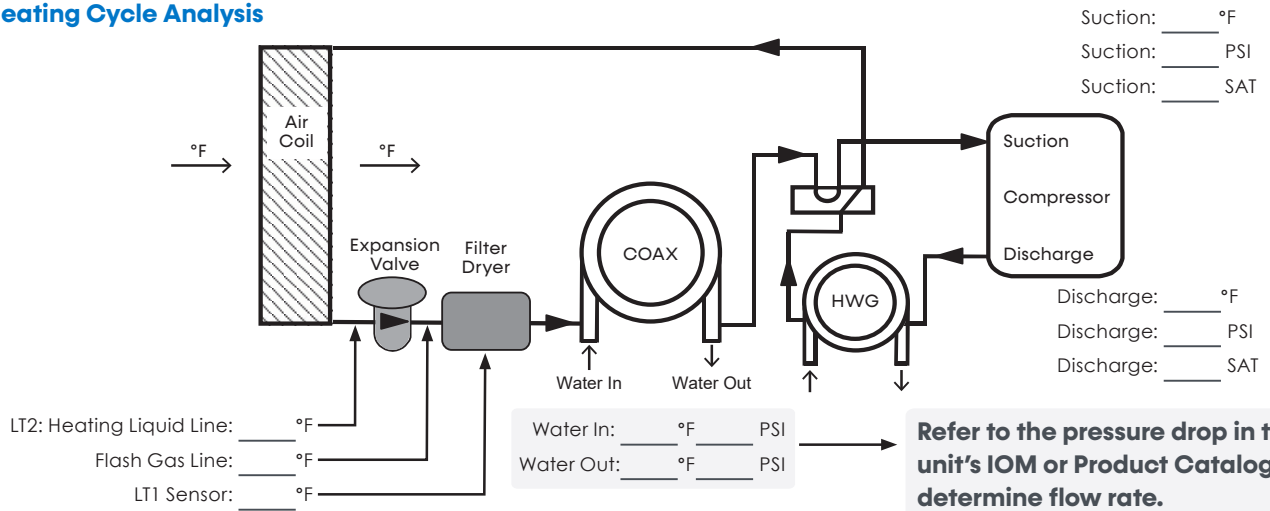

### Cooling Cycle Analysis

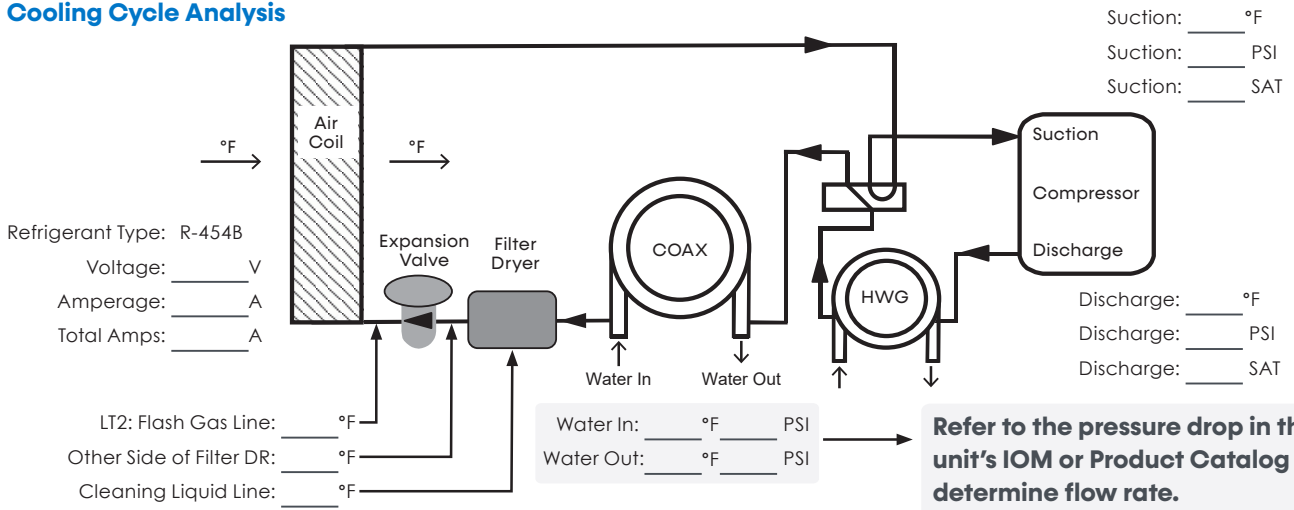

Refrigerant Type: R-454B  
 Voltage: \_\_\_\_\_ V  
 Amperage: \_\_\_\_\_ A  
 Total Amps: \_\_\_\_\_ A

LT2: Flash Gas Line: \_\_\_\_\_ °F  
 Other Side of Filter DR: \_\_\_\_\_ °F  
 Cleaning Liquid Line: \_\_\_\_\_ °F

**Heat of Extraction (Absorption) or Heat of Rejection =**

\_\_\_\_\_ flow rate (GPM) x \_\_\_\_\_ temperature differential (°F) x \_\_\_\_\_ fluid factor<sup>†</sup> = \_\_\_\_\_  
 Superheat = Suction temperature - suction saturation temperature = \_\_\_\_\_  
 Supercooling = Discharge saturation temperature - liquid line temperature = \_\_\_\_\_

**NOTES:**  
 • <sup>†</sup> Use 500 water for water, 485 for antifreeze.

**NOTE: Never connect refrigerant gauges during startup procedures. Conduct water-side analysis using P/T ports to determine water flow and temperature difference. If water-side analysis shows poor performance, refrigerant troubleshooting may be required. Connect refrigerant gauges as a last resort.**

# Warranty

Models:  
MB  
072-300



## LIMITED EXPRESS WARRANTY - MB SERIES WATER-SOURCE HEAT PUMP - COMPACT

Congratulations on purchasing your new HVAC equipment. It has been designed for long life and reliable service, and is backed by one of the strongest warranties in the industry. Your unit automatically qualifies for the warranty coverage listed below, provided you keep your proof of purchase (receipt) for the equipment and meet the warranty conditions.

### LIMITED ONE (1) YEAR PARTS EXPRESS WARRANTY

Heat Controller/Comfort-Aire/Century warrants all parts of the MB Series water-source heat pump used in commercial applications to be free from defects in workmanship and materials for normal use and maintenance for one (1) year from the date of purchase by the original consumer for the original installation. This Express Limited Warranty applies only when the water-source heat pump is installed as part of a complete matched system, and only when the system is installed per Comfort-Aire/Century installation instructions and in accordance with all local, state and national codes for normal use.

### LIMITED FIVE (5) YEAR EXTENDED EXPRESS WARRANTY ON COMPRESSOR

We will replace a compressor which proves to be defective for a period of five (5) years from date of heat pump purchase. All restrictions, limitations and procedures for the one year parts warranty apply to the additional compressor warranty period.

### EXCEPTIONS

The Limited Express Warranty does not cover normal maintenance—Comfort-Aire/Century recommends that regular inspection/maintenance be performed at least once a season and proof of maintenance be kept. Additionally, labor charges, transportation charges for replacement parts, replacement of refrigerant or filters, any other service calls/repairs are not covered by this Limited Warranty. It also does not cover any portion or component of the system that is not supplied by Comfort-Aire/Century, regardless of the cause of failure of such portion or component.

### CONDITIONS OF WARRANTY COVERAGE

- Unit must be operated according to Comfort-Aire/Century operating instructions included with the unit and cannot have been subjected to accident, alteration, improper repair, neglect or misuse, or an act of God (such as a flood)
- Serial numbers and/or rating plate have not been altered or removed
- Installation was done by a trained, licensed or otherwise qualified geothermal dealer/contractor
- Performance cannot be impaired by use of any product not authorized by Comfort-Aire/Century, or by any adjustments or adaptations to components
- Damage has not been a result of inadequate wiring or voltage conditions, use during brown-out conditions, or circuit interruptions
- Air flow around any section of the unit has not been restricted
- Unit remains in the original installation
- Unit was not purchased over the internet

### DURATION OF WARRANTY & REGISTRATION

The warranty begins on the date of purchase by the original consumer. The consumer must register their product at [www.heatcontroller.com](http://www.heatcontroller.com) within 90 days of purchase. The consumer must retain a receipted bill of sale as proof of warranty period. Without this proof, the express warranty begins on the date of shipment from the factory.

### REMEDY PROVIDED BY THE LIMITED EXPRESS WARRANTY

The sole remedy under the Limited Warranty is replacement of the defective part. If replacement parts are required within the period of this warranty, Comfort-Aire/Century replacement parts shall be used; any warranty on the replacement part(s) shall not affect the applicable original unit warranty. Labor to diagnose and replace the defective part is not covered by this Limited Express Warranty. Access to the unit for service is the owner's responsibility. If for any reason the replacement part/product is no longer available during the warranty period, Comfort-Aire/Century shall have the right to allow a credit in the amount of the current suggested retail price of the part/product instead of providing repair or replacement.

### LIMITATION OF LIABILITY

1. **EXCLUSION OF ALL IMPLIED WARRANTIES AND LIMITATION.** There are no other express or implied warranties. Comfort-Aire/Century makes no warranty of merchantability. We do not warrant that the unit is suitable for any particular purpose or can be used in buildings or rooms of any particular size or condition except as specifically provided in this document. There are no other warranties, express or implied, which extend beyond the description in this document.
2. All warranties implied by law are limited in duration to the five-year term of the Parts Warranty. Your exclusive remedy is limited to the replacement of defective parts. **We will not be liable for any consequential or incidental damages caused by any defect in this unit.**
3. This warranty gives you specific legal rights and you may also have other rights which vary from state to state. Some states do not allow limitation on how long an implied warranty lasts or do not allow the exclusion or limitation of incidental or consequential damages, so the above limitations or exclusions may not apply to you.
4. No warranties are made for units sold outside the continental United States and Canada. Your distributor or final seller may provide a warranty on units sold outside these areas.
5. Comfort-Aire/Century will not be liable for damages if our performance regarding warranty resolution is delayed by events beyond our control including accident, alteration, abuse, war, government restrictions, strikes, fire, flood, or other acts of God.

*Please follow the below steps to register your product.*

- Please log onto our website [www.heatcontroller.com](http://www.heatcontroller.com)
- Resources
- Product Registration
- Complete the requested information in all caps, especially the Email Address
- Press the "Continue" button at the bottom
- A copy of the registration will be sent to the email address that you entered at the top of the page for your records

**KEEP THIS INFORMATION AS A RECORD OF YOUR PURCHASE**

Apply Serial Number and Model Number sticker here  
(from product carton). If unavailable, write serial number and  
model number below (can be found on unit rating plate).

---

Date of Purchase \_\_\_\_\_

Component of new HVAC system

Date Installation Completed \_\_\_\_\_

Replacement heat pump only

Remember to retain your bill of sale as proof of warranty period and ownership.



Please visit [www.heatcontroller.com](http://www.heatcontroller.com) to register your new product

Models:  
MB  
072-300

## Notes

---

**Notes**

Models:  
MB  
072-300

---

Models:  
MB  
072-300

## Revision History

Date	Section	Description
03/25/26	Model Nomenclature	Updated
	Dimensional Data MB072-120 Horizontal	Updated header column names
	Dimensional Data MB072-120 Horizontal with WSE	Updated header column names
	Electrical CXM2, RDS, and Wireless Service Tool	Added the Refrigerant Detection System (RDS) AOM's QR code
12/18/25	Vertical Installation Service Access	Updated the mandatory service access to 3 feet (91.4 cm)
	Refrigerant Detection System	Updated
	Troubleshooting Table	Consolidated functional and performance troubleshooting into a single table
10/01/25	Model Nomenclature	Updated model nomenclature including product revision
	Physical Data	Added horsepower and kW values for Standard MB300 units
		Added weights for units with WSE (packaged and unpackaged)
	Horizontal Installation Service Access	Added section
	Vertical Installation Service Access	Added section
	Electrical Data	Updated the following for Standard and Dual Point Power units: <ul style="list-style-type: none"> <li>• Min/max voltage columns</li> <li>• Added data for additional voltage options for size 240-300 models</li> </ul>
	Electrical Example VFD Wiring Diagram	Added section
	Electrical VFD Adjustment	Added section
	Blower Performance	Added Standard MB300 performance
	Operating Limits and Commissioning Conditions	Updated MOD and MWV working water pressures
	Blower Performance	Updated size 072 models at 0.80 BHP for 1,900 SCFM to 0.58
All	Updated organization, figure references, and table references	



1900 Wellworth Ave. | Jackson, MI 49203  
 Phone: 517-787-2100  
[www.heatcontroller.com](http://www.heatcontroller.com)



Due to ongoing product improvements, specifications and dimensions are subject to change and correction without notice or incurring obligations. Determining the application and suitability for use of any product is the responsibility of the installer. Additionally, the installer is responsible for verifying dimensional data on the actual product prior to beginning any installation preparations.

Incentive and rebate programs have precise requirements as to product performance and certification. All products meet applicable regulations in effect on date of manufacture; however, certifications are not necessarily granted for the life of a product. Therefore, it is the responsibility of the applicant to determine whether a specific model qualifies for these incentive/rebate programs.

Engineered and assembled in the USA.

© Heat Controller, Inc. All Rights Reserved 2024