

**COMMERCIAL**  
MW WATER-TO-WATER SERIES

# **INSTALLATION, OPERATION & MAINTENANCE MANUAL**

Part#: 97B0164N03 | Revised: March 27, 2026

Models: MW 036-120  
60Hz – R-454B



Models:  
MW  
036-120

## Table of Contents

<b>3</b>	Model Nomenclature	<b>31</b>	Electrical
<b>4</b>	Attentions, Cautions, and Warnings	<b>31</b>	Power Wiring
<b>6</b>	General Information	<b>32</b>	Example Wiring Diagram
<b>8</b>	Refrigerant System Servicing	<b>34</b>	Low-Voltage Wiring
<b>11</b>	Physical Data	<b>37</b>	Thermostat Wiring
<b>12</b>	Installation	<b>38</b>	Refrigerant Detection System
<b>14</b>	Dimensional Data	<b>39</b>	DXM2.6, RDS, and Wireless Service Tool
<b>15</b>	Service Access	<b>40</b>	Unit and System Checkout
<b>16</b>	Applications	<b>41</b>	Unit Startup Procedure
<b>16</b>	Variable Water Flow	<b>43</b>	Operating Pressures
<b>17</b>	Ground-Loop Heat Pump	<b>45</b>	Preventative Maintenance
<b>21</b>	Ground-Water Heat Pump	<b>46</b>	Startup Log Sheet
<b>23</b>	Water Quality Requirements	<b>47</b>	Refrigeration Troubleshooting Form
<b>26</b>	Load Plumbing Configuration	<b>48</b>	Warranty
<b>27</b>	Hot Water Generator	<b>52</b>	Revision History
<b>30</b>	Electrical Data		

Heat Controller works continually to improve its products. As a result, the design and specifications of each product at the time of order may be changed without notice and may not be as described herein. Please contact Heat Controller's Customer Service Department at 517-787-2100 for specific information on the current design and specifications. Statements and other information contained herein are not express warranties and do not form the basis of any bargain between the parties, but are merely Heat Controller's opinion or commendation of its products.

# Model Nomenclature

1	2	3	4	5	6	7	8	9	10	11	12	13	14	15
M	W	M	0	3	6	A	G	D	0	0	0	G	B	S

**PRODUCT NAME**  
M = R-454B Refrigerant

**MODEL TYPE**  
W = Water-to-Water Series

**APPLICATION**  
M = Medium Temperature

**SIZE**  
036  
060  
120

**REVISION**  
A = Current

**VOLTAGE**  
G = 208/230-1-60    J = 208/230-1-60 Refrigerant Detection System  
H = 208/230-3-60    K = 208/230-3-60 Refrigerant Detection System  
E = 265-1-60         D = 265-1-60 Refrigerant Detection System  
F = 460-3-60         L = 460-3-60 Refrigerant Detection System

**CONTROLS**

Control	Standard	MPC
DXM2.6	D	P
DXM2.6 with Disconnect	B	S

**CABINET**

Cabinet	Sound Attenuation Package	Option
Commercial	No	0
	Yes	5

**STANDARD**  
S = Standard

**RESERVED FOR FUTURE**  
0 = None

**EXTENDED OPTIONS**  
0 = Standard  
G = Hot Water Generator (HWG)

**LOAD SIDE OPTIONS**

Description	Standard
None	0

**SOURCE SIDE OPTIONS**

Description	Standard
None	0
Modulating Valve	C

Models:  
MW  
036-120

# Attentions, Cautions, and Warnings

## SAFETY

Warnings, cautions, and notices appear throughout this manual. Read these items carefully before attempting any installation, service, or troubleshooting of the equipment.

**DANGER:** Indicates an immediate hazardous situation, which if not avoided will result in death or serious injury. DANGER labels on unit access panels must be observed.

**WARNING:** Indicates a potentially hazardous situation, which if not avoided could result in death or serious injury.

**CAUTION:** Indicates a potentially hazardous situation or an unsafe practice, which if not avoided could result in minor or moderate injury or product or property damage.

**ATTENTION:** Notification of installation, operation, or maintenance information, which is important, but which is not hazard-related.

**⚠ WARNING**



Disconnect power supply(ies) before servicing. Refer servicing to qualified service personnel. Electric shock hazard. May result in injury or death!

**⚠ WARNING**

To avoid the release of refrigerant into the atmosphere, the refrigerant circuit of this unit must be serviced only by technicians who meet local, state, and federal proficiency requirements.

**⚠ WARNING**

The installation of water-source heat pumps and all associated components, parts, and accessories which make up the installation shall be in accordance with the regulations of ALL authorities having jurisdiction and MUST conform to all applicable codes. It is the responsibility of the installing contractor to determine and comply with ALL applicable codes and regulations.

**⚠ WARNING**

The appliance shall be stored in a room without continuously operating ignition sources (for example: open flames, an operating gas appliance or an operating electric heater).

**⚠ WARNING**

All refrigerant discharged from this unit must be recovered WITHOUT EXCEPTION. Technicians must follow industry accepted guidelines and all local, state, and federal statutes for the recovery and disposal of refrigerants. If a compressor is removed from this unit, refrigerant circuit oil will remain in the compressor. To avoid leakage of compressor oil, refrigerant lines of the compressor must be sealed after it is removed.

**⚠ WARNING**

This appliance is not intended for use by persons (including children) with reduced physical, sensory, or mental capabilities, or lack of experience and knowledge, unless they have been given supervision or instruction concerning use of the appliance by a person responsible for their safety.

**⚠ WARNING**

An unventilated area where the appliance using FLAMMABLE REFRIGERANTS is installed shall be so constructed that should any refrigerant leak, it will not stagnate so as to create a fire or explosion hazard.

**⚠ WARNING**

Auxiliary devices which may be a POTENTIAL IGNITION SOURCE shall not be installed in the duct work. Examples of such POTENTIAL IGNITION SOURCES are hot surfaces with a temperature exceeding 1,292°F (700°C)

**⚠ WARNING**

An unventilated area where a water-source heat pump is installed and surpasses a R-454B refrigerant charge of 62 oz (1.76 kg), shall be without continuously operating open flames (for example an operating gas appliance) or other POTENTIAL IGNITION SOURCES (for example, an operating electric heater, hot surfaces).

**⚠ WARNING**

Only auxiliary electric heaters approved by the manufacturer shall be installed in connecting ductwork. The installation of any other auxiliary devices is beyond the manufacturer's responsibility.

**⚠ WARNING**

For mechanical ventilation, the lower edge of the air extraction opening where air is exhausted from the room shall not be more than 3.94 inches (100 mm) above the floor. The location where the mechanical ventilation air extracted from the space is discharged shall be separated by a sufficient distance, but not less than 9.84 feet (3 m), from mechanical ventilation air intake openings, to prevent recirculation to the space.

**⚠ WARNING**

Children being supervised are NOT to play with the appliance.

**⚠ WARNING**

Do not pierce or burn.

**⚠ WARNING**

Be aware that refrigerants may not contain odor.

## Attentions, Cautions, and Warnings

### CAUTION

DO NOT store or install units in corrosive environments or in locations subject to temperature or humidity extremes (e.g., attics, garages, rooftops, etc.). Corrosive conditions and high temperature or humidity can significantly reduce performance, reliability, and service life. Always move and store units in an upright position. Tilting units on their sides will cause equipment damage.

### CAUTION

CUT HAZARD - Failure to follow this caution may result in personal injury. Sheet metal parts may have sharp edges or burrs. Use care and wear appropriate protective clothing, safety glasses and gloves when handling parts and servicing heat pumps.

### CAUTION

To avoid equipment damage, DO NOT use these units as a source of heating or cooling during the construction process. The mechanical components and filters can quickly become clogged with construction dirt and debris, which may cause system damage and void product warranty.

### CAUTION

All three phase scroll compressors must have direction of rotation verified at startup. Verification is achieved by checking compressor Amp draw. Amp draw will be substantially lower compared to nameplate values. Additionally, reverse rotation results in an elevated sound level compared to correct rotation. Reverse rotation will result in compressor internal overload trip within several minutes. Verify compressor type before proceeding.

### ATTENTION

Servicing shall be performed only as recommended by the manufacturer.

### ATTENTION

REFRIGERANT SENSORS for REFRIGERANT DETECTION SYSTEMS shall only be replaced with sensors specified by the appliance manufacturer.

### ATTENTION

An unconditioned attic is not considered natural ventilation.

### ATTENTION

LEAK DETECTION SYSTEM installed. Unit must be powered except for service.

Models:  
MW  
036-120

## General Information

### INSPECTION

Upon receipt of the equipment, carefully check the shipment against the bill of lading. Make sure all units have been received. Inspect the packaging of each unit, and inspect each unit for damage. Ensure that the carrier makes proper notation of any shortages or damage on all copies of the freight bill and completes a common carrier inspection report. Concealed damage not discovered during unloading must be reported to the carrier within 15 days of receipt of shipment. If not filed within 15 days, the freight company can deny the claim without recourse.

**NOTE: It is the responsibility of the purchaser to file all necessary claims with the carrier. Notify your equipment supplier of all damage within 15 days of shipment.**

### STORAGE

Equipment should be stored in its original packaging in a clean, dry area. Store units in an upright position at all times. You may stack a maximum of three units high.

### UNIT PROTECTION

Cover units on the job site with either the original packaging or an equivalent protective covering. Cap the open ends of pipes stored on the job site. In areas where painting, plastering, and/or spraying has not been completed, all due precautions must be taken to avoid physical damage to the units and contamination by foreign material. Physical damage and contamination may prevent proper startup and may result in costly equipment cleanup.

Examine all pipes, fittings, and valves before installing any of the system components. Remove any dirt or debris found in or on these components.

### PRE-INSTALLATION

Installation, Operation, and Maintenance instructions are provided with each unit. Other unit configurations are typically installed in a mechanical room. The installation site chosen should include adequate service clearance around the unit. Before unit startup, read all manuals and become familiar with the unit and its operation. Thoroughly check the system before operation.

### PREPARE UNITS FOR INSTALLATION AS FOLLOWS:

1. Compare the electrical data on the unit nameplate with ordering and shipping information to verify that the correct unit has been shipped.
2. Keep the cabinet covered with the original packaging until installation is complete and all plastering, painting, etc. is finished.
3. Verify refrigerant tubing is free of kinks or dents and that it does not touch other unit components.
4. Inspect all electrical connections. Connections must be clean and tight at the terminals.
5. Locate and verify any hot water generator (HWG), hanger, or other accessory kit located in the compressor section.

### CHECKS TO THE AREA

Prior to beginning work on systems containing FLAMMABLE REFRIGERANTS, safety checks are necessary to ensure that the risk of ignition is minimized. For repair to the REFRIGERATING SYSTEM, these steps shall be completed prior to conducting work on the system.

#### Work Procedure

Work shall be undertaken under a controlled procedure so as to minimize the risk of a flammable gas or vapor being present while the work is being performed.

#### General Work Area

All maintenance staff and others working in the local area shall be instructed on the nature of work being carried out. Work in confined spaces shall be avoided.

## General Information

### Checking for presence of refrigerant

The area shall be checked with an appropriate refrigerant detector prior to and during work, to ensure the technician is aware of potentially toxic or flammable atmospheres. Ensure that the leak detection equipment being used is suitable for use with all applicable refrigerants, i.e. non-sparking, adequately sealed or intrinsically safe.

### Presence of fire Extinguisher

If any hot work is to be conducted on the refrigeration equipment or any associated parts, appropriate fire extinguishing equipment shall be available to hand. Have a dry powder or CO<sub>2</sub> fire extinguisher adjacent to the charging area.

### No ignition sources

No person carrying out work in relation to a REFRIGERATION SYSTEM which involves exposing any pipe work shall use any sources of ignition in such a manner that it may lead to the risk of fire or explosion. All possible ignition sources, including cigarette smoking, should be kept sufficiently far away from the site of installation, repairing, removing and disposal, during which refrigerant can possibly be released to the surrounding space. Prior to work taking place, the area around the equipment is to be surveyed to make sure that there are no flammable hazards or ignition risks. "No Smoking" signs shall be displayed.

### Ventilated area

Ensure that the area is in the open or that it is adequately ventilated before breaking into the system or conducting any hot work. A degree of ventilation shall continue during the period that the work is carried out. The ventilation should safely disperse any released refrigerant and preferably expel it externally into the atmosphere.

### Checks to the Refrigeration Equipment

The following checks shall be applied to installations using FLAMMABLE REFRIGERANTS:

- The actual REFRIGERANT CHARGE is in accordance with the room size within which the refrigerant containing parts are installed;
- The ventilation machinery and outlets are operating adequately and are not obstructed;

- If an indirect refrigerating circuit is being used, the secondary circuit shall be checked for the presence of refrigerant;
- Marking to the equipment continues to be visible and legible. Markings and signs that are illegible shall be corrected;
- Refrigerant piping or components are installed in a position where they are unlikely to be exposed to any substance which may corrode refrigerant containing components, unless the components are constructed of materials which are inherently resistant to being corroded or are suitably protected against being so corroded.

### Checks to Electrical Devices

Repair and maintenance to electrical components shall include initial safety checks and component inspection procedures. If a fault exists that could compromise safety, then no electrical supply shall be connected to the circuit until it is satisfactorily dealt with. If the fault cannot be corrected immediately but it is necessary to continue operation, an adequate temporary solution shall be used. This shall be reported to the owner of the equipment so all parties are advised.

Initial safety checks shall include:

- Capacitors are discharged: this shall be done in a safe manner to avoid possibility of sparking
- That no live electrical components and wiring are exposed while charging, recovering, or purging the system
- That there is continuity of earth bonding

## REPAIR TO INTRINSICALLY SAFE COMPONENTS

Intrinsically safe components must be replaced.

## CABLING

Check that cabling will not be subject to wear, corrosion, excessive pressure, vibration, sharp edges or any other adverse environmental effects. The check shall also take into account the effects of aging or continual vibration from sources such as compressors or fans.

# Refrigerant System Servicing

## REFRIGERANT SYSTEM

To maintain sealed circuit integrity, do not install service gauges unless unit operation appears abnormal. Reference the operating charts for pressures and temperatures. Verify that air and water flow rates are at proper levels before servicing the refrigerant circuit.

### Removal and Evacuation

When breaking into the refrigerant circuit to make repairs - or for any other purpose - conventional procedures shall be used. However, for flammable refrigerants it is important that best practice be followed, since flammability is a consideration. The following procedure shall be adhered to:

- Safely remove refrigerant following local and national regulations
- Evacuate
- Purge the circuit with Inert gas
- Evacuate
- Continuously flush or purge with Inert gas when using flame to open circuit
- Open the circuit

The refrigerant charge shall be recovered into the correct recovery cylinders. For appliances containing flammable refrigerants, the system shall be purged with oxygen-free nitrogen to render the appliance safe. This process might need to be repeated several times. Compressed air or oxygen shall not be used for purging refrigerant systems.

For appliances containing flammable refrigerants, refrigerant purging shall be achieved by breaking the vacuum in the system with oxygen-free nitrogen and continuing to fill until the working pressure is achieved, then venting to atmosphere, and finally pulling down to a vacuum (optional for FLAMMABLE REFRIGERANT). This process shall be repeated until no refrigerant remains in the system (optional for FLAMMABLE REFRIGERANT). When the final oxygen-free nitrogen charge is used, the system shall be vented down to atmospheric pressure to enable work to take place.

The outlet for the vacuum pump shall not be close to any potential ignition sources, and ventilation shall be available.

### Charging Procedures

In addition to conventional charging procedures, the following requirements shall be followed:

- Ensure that contamination of different refrigerants does not occur when using charging equipment
- Hoses or lines shall be as short as possible to minimize the amount of refrigerant contained in them
- Cylinders shall be kept in an appropriate position according to the instructions
- Ensure that the REFRIGERATION SYSTEM is earthed prior to charging the system with refrigerant
- Label the system when charging is complete (if not already)
- Extreme care shall be taken not to overfill the REFRIGERATION SYSTEM

Prior to recharging the system, it shall be pressure-tested with the appropriate purging gas. The system shall be leak-tested on completion of charging but prior to commissioning. A follow up leak test shall be carried out prior to leaving the site.

### Leak Detection

Under no circumstances shall potential sources of ignition be used in the searching for or detection of refrigerant leaks. A halide torch (or any other detector using a naked flame) shall not be used.

The following leak detection methods are deemed acceptable for all refrigerant systems.

Electronic leak detectors may be used to detect refrigerant leaks but, in the case of FLAMMABLE REFRIGERANTS, the sensitivity may not be adequate, or may need re-calibration. Detection equipment shall be calibrated in a refrigerant-free area.

## Refrigerant System Servicing

Ensure that the detector is not a potential source of ignition and is suitable for the refrigerant used. Leak detection equipment shall be set at a percentage of the lower flammability limit of the refrigerant and shall be calibrated to the refrigerant employed, and the appropriate percentage of gas (25% maximum) is confirmed.

Leak detection fluids are also suitable for use with most refrigerants but the use of detergents containing chlorine shall be avoided as the chlorine may react with the refrigerant and corrode the copper pipework.

### NOTE:

Examples of leak detection fluids are:

- Bubble method
- Fluorescent method agents

If a leak is suspected, all naked flames shall be removed/extinguished.

If a refrigerant leak that requires brazing is identified, all of the refrigerant shall be recovered from the system, or isolated (by means of shutoff valves) in a part of the system remote from the leak. Removal of refrigerant shall be according to Removal and Evacuation section.

## DECOMMISSIONING

Before carrying out this procedure, it is essential that the technician is completely familiar with the equipment and all its detail. It is recommended good practice that all refrigerants are recovered safely. Prior to the task being carried out, an oil and refrigerant sample shall be taken in case analysis is required prior to re-use of recovered refrigerant. It is essential that electrical power is available before the task is commenced.

1. Become familiar with the equipment and its operation
2. Isolate system electrically

3. Before attempting the procedure, ensure that:
  - Mechanical handling equipment is available, if required, for handling refrigerant cylinders
  - All personal protective equipment is available and being used correctly
  - The recovery process is supervised at all times by a competent person
  - Recovery equipment and cylinders conform to the appropriate standards
4. Pump down refrigerant system, if possible
5. If a vacuum is not possible, make a manifold so that refrigerant can be removed from various parts of the system
6. Make sure that cylinder is situated on the scales before recovery takes place
7. Start the recovery machine and operate in accordance with instructions
8. Do not overfill cylinders (no more than 80% volume liquid charge)
9. Do not exceed the maximum working pressure of the cylinder, even temporarily
10. When the cylinders have been filled correctly and the process completed, ensure that the cylinders and the equipment are removed from site promptly and all isolation valves on the equipment are closed off
11. Recovered refrigerant shall not be charged into another REFRIGERATING SYSTEM unless it has been cleaned and checked

**Labeling** - Upon decommissioning, equipment shall be labeled stating that it has been decommissioned and emptied of refrigerant. The label shall be dated and signed.

Models:  
MW  
036-120

## Refrigerant System Servicing

### RECOVERY

When removing refrigerant from a system, either for servicing or decommissioning, it is recommended good practice that all refrigerants are removed safely.

When transferring refrigerant into cylinders, ensure that only appropriate refrigerant recovery cylinders are employed. Ensure that the correct number of cylinders for holding the total system charge is available. All cylinders to be used are designated for the recovered refrigerant and labeled for that refrigerant (i.e. special cylinders for the recovery of refrigerant). Cylinders shall be complete with pressure-relief valve and associated shutoff valves in good working order. Empty recovery cylinders are evacuated and, if possible, cooled before recovery occurs.

The recovery equipment shall be in good working order with a set of instructions concerning the equipment that is at hand and shall be suitable for the recovery of the flammable refrigerant. If in doubt, the manufacturer should be consulted.

In addition, a set of calibrated weighing scales shall be available and in good working order. Hoses shall be complete with leak-free disconnect couplings and in good condition.

The recovered refrigerant shall be processed according to local legislation in the correct recovery cylinder, and the relevant waste transfer note arranged. Do not mix refrigerants in recovery units and especially not in cylinders.

If compressors or compressor oils are to be removed, ensure that they have been evacuated to an acceptable level to make certain that flammable refrigerant does not remain within the lubricant. The compressor body shall not be heated by an open flame or other ignition sources to accelerate this process. When oil is drained from a system, it shall be carried out safely.

# Physical Data

Models:  
MW  
036-120

## MW Series

Unit Size	MW036	MW060	MW120
Number of refrigerant circuits	1	1	2
Factory Charge R-454B - (oz.) (per circuit)	42	48	48
Refrigerant Leak Detection System	O	O	O
<b>Water Connection Size</b>			
Source/Load - FPT	1"		1-1/2"
HWG - FPT	1/2"		
<b>Weight</b>			
Weight - Operating (lbs) [kg]	187 [85]	239 [108]	496 [224]
Weight - Shipping (lbs) [kg]	212 [96]	264 [120]	520 [235]
<b>Water Volume</b>			
Gallons [Liters]	0.56 [2.12]	0.7 [2.65]	1.40 [5.30]

- O = Optional, R = Required

Models:  
MW  
036-120

## Installation

### LOCATION

These units are not designed for outdoor installation. Locate the unit in an INDOOR area that allows enough space for service personnel to perform typical maintenance or repairs.

**The installation of water-source heat pump units and all associated components, parts and accessories which make up the installation shall be in accordance with the regulations of ALL authorities having jurisdiction and MUST conform to all applicable codes. It is the responsibility of the installing contractor to determine and comply with ALL applicable codes and regulations.**

Locate the unit in an indoor area that allows easy removal of access panels and has enough space for service personnel to perform maintenance or repair. Provide sufficient room to make water and electrical connections. Remove any access panel screws that would be difficult to remove after the unit is installed prior to setting the unit. These units are not approved for outdoor installation and must be installed inside the structure being conditioned. Do not locate in areas where ambient conditions are not maintained within 40-100°F (4-38°C).

# Installation

Models:  
MW  
036-120

## SUPPLY AND RETURN PIPING INSTALLATION

Follow these piping guidelines:

1. Install a drain valve at the base of each supply and return line to facilitate system flushing.
2. Install shutoff/balancing valves and unions at each unit to permit unit removal for servicing.
3. Place strainers at the inlet of each system circulating pump.
4. Select the proper hose length to allow slack between connection points. Hoses may vary in length by +2% to -4% under pressure.
5. Exceeding the minimum bend radius may cause the hose to collapse resulting in reduced water flow rate. Install an angle adapter to avoid sharp bends in the hose when the radius falls below the required minimum and causes a slight kink.

Insulation is not required on loop water piping except where the piping runs through unheated areas or outside the building or when the loop water temperature is below the minimum expected dew point of the pipe ambient temperature.

Optional pressure-rated hose assemblies designed specifically for use with the manufacturer's units are available. You can purchase similar hoses from alternate suppliers. Supply and return hoses are fitted with swivel-joint fittings at one end to prevent kinking.

Refer to the **Supply/Return Hose Kit** figure for an example of a supply/return hose kit. Male adapters secure hose assemblies to the unit and risers. Install hose assemblies properly and check them regularly to avoid system failure and reduced service life.

Pipe-joint compound is not necessary when water-thread sealant tape is pre-applied to hose assemblies or when flared-end connections are used. If pipe-joint compound is preferred, use compound only in small amounts on the pipe threads of the fitting adapters. Prevent sealant from reaching the flared surfaces of the joint.

**NOTE: When antifreeze is used in the loop, ensure it is compatible with water-thread sealant tape or the pipe-joint compound in use.**

The maximum allowable torque for brass fittings is 30 ft-lbs (41 N-m). If a torque wrench is not available, tighten finger-tight plus one-quarter turn. Tighten steel fittings as necessary.

**Figure 1: Supply/Return Hose Kit**

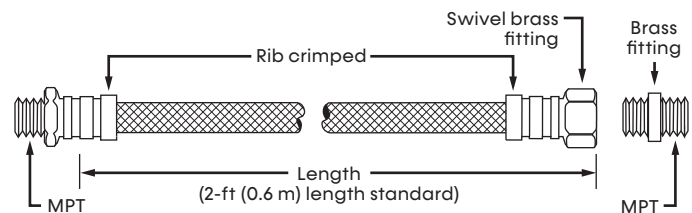

### WARNING

Piping must comply with all applicable codes.

### WARNING

Do not bend or kink supply lines

### WARNING

Polyolester Oil, commonly known as POE oil, is a synthetic oil used in many refrigeration systems including those with R-454B refrigerant. POE oil, if it ever comes in contact with PVC or CPVC piping, may cause failure of the PVC/CPVC. PVC/CPVC piping should never be used as supply or return water piping with water source heat pump products containing R-454B as system failures and property damage may result.

### CAUTION

Corrosive system water requires corrosion-resistant fittings and hoses and may require water treatment.

Models:  
MW  
036-120

# Installation Dimensional Data

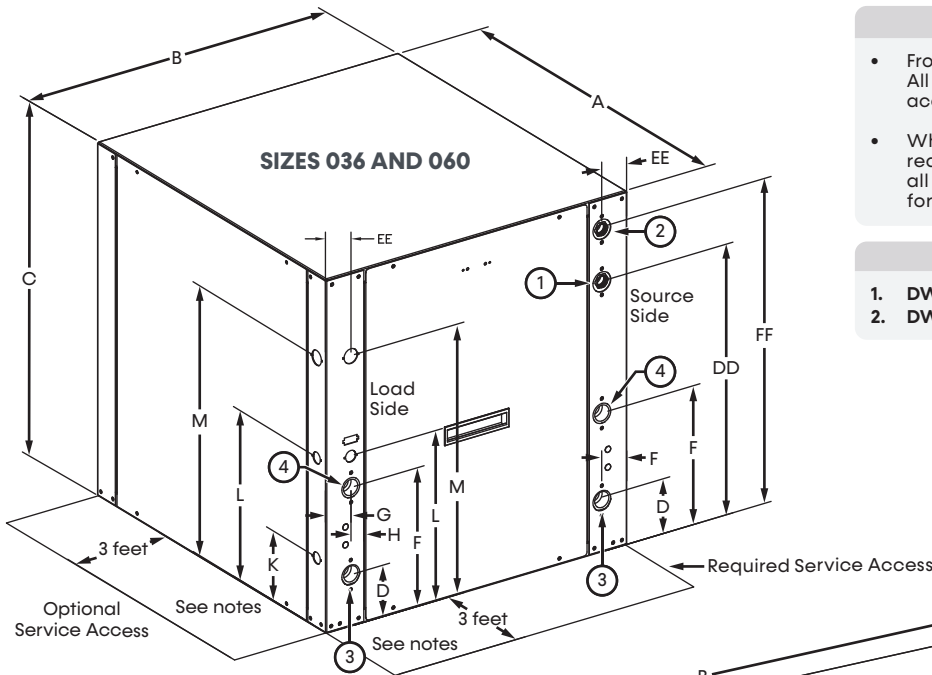

**NOTES**

- Front and side access is preferred for service access. All components may be serviced from the front access panel if side access is not available.)
- While clear access to all removable panels is not required, installer should take care to comply with all building codes and allow adequate clearance for future field service.

**LEGEND**

- |            |              |
|------------|--------------|
| 1. DWH IN  | 3. WATER IN  |
| 2. DWH OUT | 4. WATER OUT |

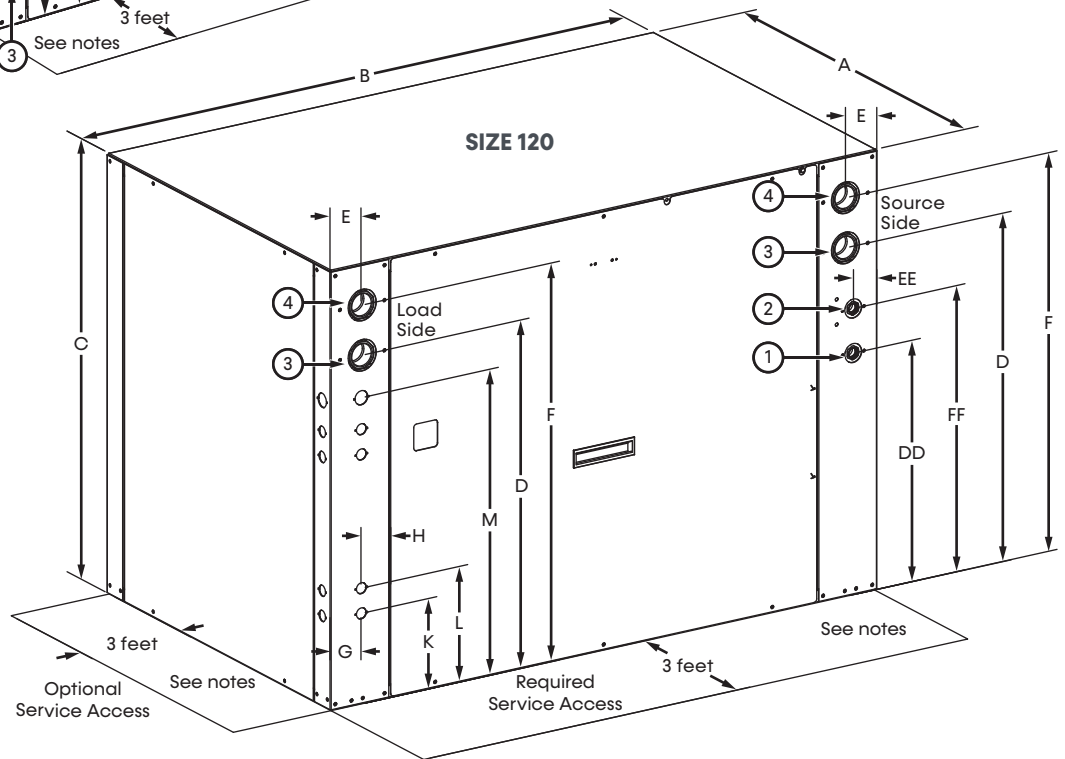

Unit Size	Overall Cabinet			Water Connections										Electrical Knockouts									
	Depth/Length	Width	Height	Water In (Source)		Water Out (Source)		Water In (Load)		Water Out (Load)		Water In/Out Φ	HWG In		HWG Out		Low Voltage		High Voltage		G	H	
	A	B	C	D	E	F	E	D	E	F	E	Φ	DD	EE	FF	EE	Φ	K	L	M			
																			KO 1/2"		KO 3/4"		
036-060	inch	27.5	25.4	27.0	4.0	2.2	10.6	2.2	4.0	2.2	10.6	2.2	1.0	20.6	2.1	24.6	2.1	0.5	5.4	13.0	20.6	2.1	1.1
	cm	69.9	64.5	68.6	10.1	5.5	26.9	5.5	26.9	5.5	10.1	5.5	2.5	52.3	5.3	62.5	5.3	1.3	13.7	33.0	52.2	5.3	2.9
120	inch	30.6	48.8	34.8	27.7	2.8	31.7	2.8	27.7	2.8	31.7	2.8	1.5	19.2	2.1	22.8	2.1	0.5	7.2	9.2	24.3	2.8	1.1
	cm	77.7	124.0	88.4	70.4	7.2	80.5	7.2	80.5	7.2	70.4	7.2	3.8	48.8	5.4	57.9	5.3	1.3	18.3	23.4	61.6	7.0	2.9

# Installation Service Access

Models:  
MW  
036-120

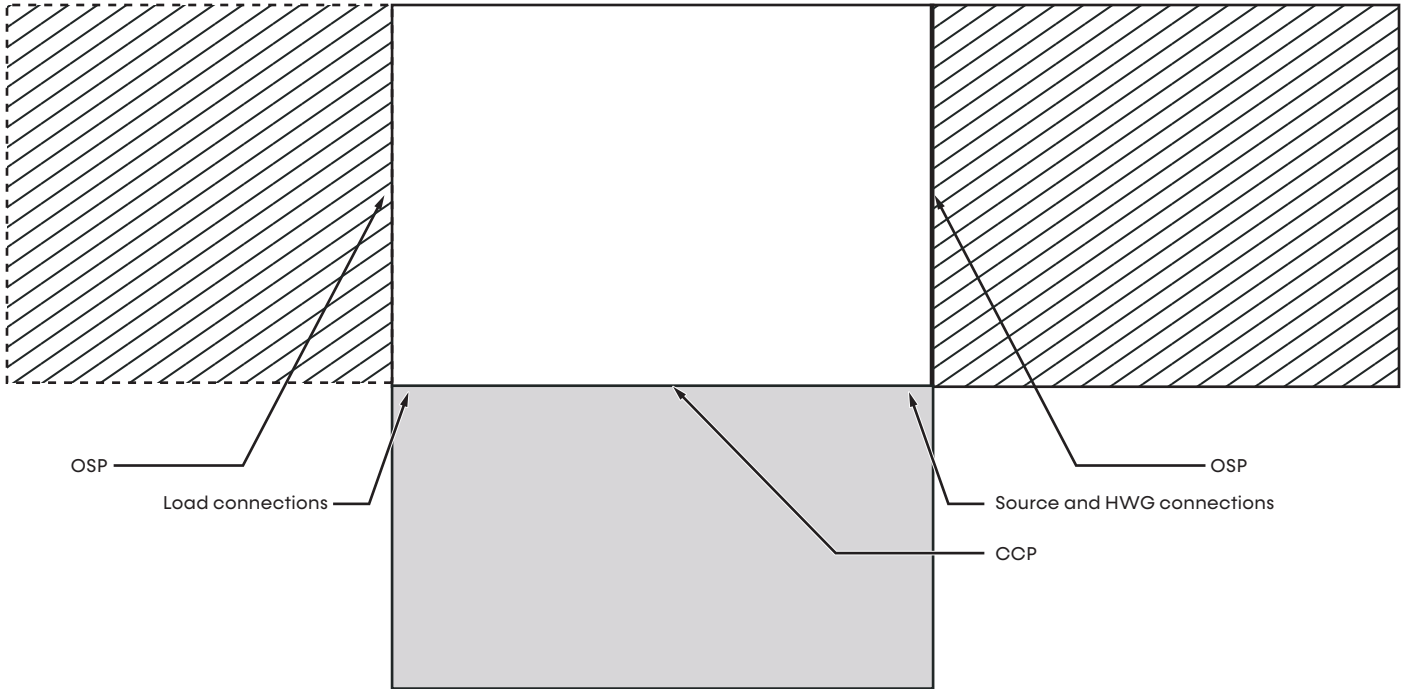



### NOTES

1. While clear access to all removable panels is not required, installer should take care to comply with all building codes and allow adequate clearance for future field service.
2. Front and side access is preferred for service access. However, all components may be serviced from the front access panel if side access is not available.
3. OSP are removable panels that provide additional access to the units interior. Clear access to OSP panels is not required and they are not to be used in place of the mandatory CCP and BSP panels.
4. All water connections are on the front of the unit. Electrical wiring can be made on on either side of the corner post.

### LEGEND

**CCP = CONTROL/COMPRESSOR ACCESS**  
**OSP = OPTIONAL SERVICE PANEL (NOT REQUIRED)**

-  = Mandatory Service Access 3 feet (91.4 cm)
-  = Optional Service Access 3 feet (91.4 cm)

Models:  
MW  
036-120

# Applications Variable Water Flow

Variable Water Flow is a revolutionary new, intelligent and efficient way to circulate water (or water plus antifreeze) using internal, variable-speed water flow control. The factory-installed high efficiency variable-speed pumps uses almost half the wattage of a traditional fixed-speed pump. Variable Water Flow technology improves the life expectancy of the unit by reducing the amount of energy required to optimize the flow of water throughout the system and also reduces the space, cost, and labor required to install external water flow control mechanisms (flow controllers, solenoid, and flow-control valves).

Variable-speed pumps or motorized modulating valves deliver variable water flow, controlled by DXM2.6, based on loop water  $\Delta T$ .



## VARIABLE WATER FLOW CONFIGURATIONS

- **Low System Pressure Drop Modulating Motorized Valve – Typical for External Central Pumping.**

Primarily for use on multi-unit applications with central pumping. With this option, the unit includes a low pressure drop, high  $C_v$  modulating motorized water valve that is controlled by the DXM2.6 based on the difference in the entering and leaving water temperature  $\Delta T$ . This valve is a factory-installed feature.

## WATER PRESSURE SCHRADER PORTS

The built-in pressure ports are provided to measure pressure drop through the water-to-refrigerant heat exchanger. The water pressure ports are Schrader ports smaller than refrigerant Schrader ports. They are the same size as tire Schrader ports. A digital pressure gauge is recommended for taking pressure readings through these ports. Determine the water flow through the unit by measuring the water pressure at the water pressure out port and subtracting it from the water pressure at the water pressure in port. Comparing the pressure differential to the **Brazed-Plate Water Pressure Drop** table this manual helps calculate the flow rate through the unit.

### Typical Open Loop Application (Shown with Internal Modulating Motorized Valve)

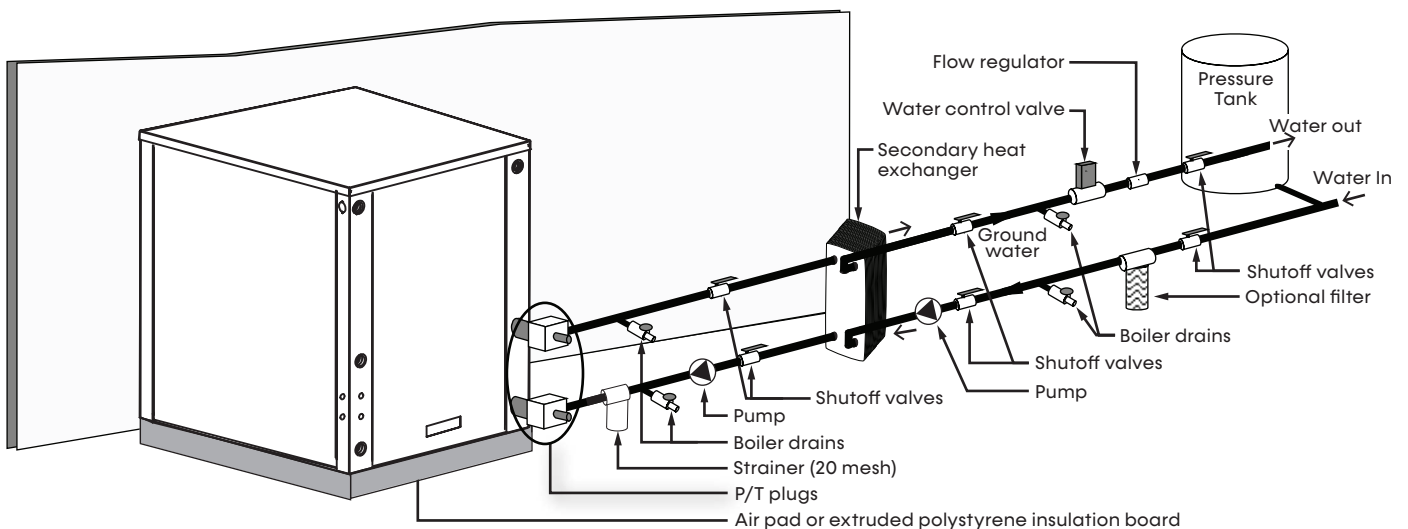

**NOTE: For use on applications using external source for flow.**

# Applications Ground-Loop Heat Pump

Models:  
MW  
036-120

## CAUTION

The following instructions represent industry accepted installation practices for closed-loop earth-coupled heat-pump systems. Instructions are provided to assist the contractor in installing trouble-free ground loops. These instructions are recommendations only. State/provincial and local codes MUST be followed and installation MUST conform to ALL applicable codes. It is the responsibility of the installing contractor to determine and comply with ALL applicable codes and regulations.

## CAUTION

Ground-loop applications require extended-range equipment and optional refrigerant/water circuit insulation.

## PRE-INSTALLATION

Prior to installation, locate and mark all existing underground utilities, piping, etc. Install loops for new construction before sidewalks, patios, driveways, and other construction has begun. During construction, accurately mark all ground-loop piping on the plot plan as an aid in avoiding potential future damage to the installation.

## PIPING INSTALLATION

Limit all ground-loop piping materials to polyethylene fusion only for in-ground sections of the loop. Do not use galvanized or steel fittings at any time due to their tendency to corrode. Do not use any plastic-to-metal threaded fittings due to their potential to leak in earth-coupled applications. Use flanged fittings as a substitute. Use P/T plugs for easy flow measurement using the pressure drop of the unit heat exchanger.

Ground-loop temperatures can range between 25 and 110°F (-4 to 43°C). Flow rates between 2.25 and 3 GPM (2.41 to 3.23 l/m per kW) of cooling capacity is recommended in these applications.

Test individual horizontal loop circuits before backfilling. Test vertical U-bends and pond loop assemblies prior to installation. Use pressures of at least 100 psi (689 kPa) when testing. Do not exceed the pipe pressure rating. Test the entire system when all loops are assembled.

## FLUSHING THE GROUND LOOP

After system installation and testing is complete, flush the system to remove all foreign objects and purge to remove all air.

## ANTIFREEZE

For operation when water is used instead of an antifreeze solution, you must calculate the leaving water temperature (LWT). Flow must be maintained to a level such that the LWT is maintained above 40°F (4.4°C) when the JW3 jumper is not clipped. Otherwise, use appropriate levels of a proper antifreeze solution in systems with leaving water temperatures of 40°F (4.4°C) or below (or where piping is routed through areas subject to freezing) and clip the JW3 jumper. Alcohols and glycols are commonly used as antifreeze. Consult your local sales office to determine the antifreeze best suited to your area. Maintain freeze protection to 15°F (9°C) below the lowest expected entering loop temperature. For example, if 30°F (-1°C) is the minimum expected entering loop temperature, the leaving loop temperature is 22 to 25°F (-6 to -4°C) and freeze protection is at 15°F (-10°C).

Calculation is as follows:

$$30^{\circ}\text{F} - 15^{\circ}\text{F} = 15^{\circ}\text{F} \quad [-1^{\circ}\text{C} - 9^{\circ}\text{C} = -10^{\circ}\text{C}]$$

Premix and pump all alcohols from a reservoir outside of the building when possible. If an outside reservoir is not available, introduce alcohol under the water level to prevent fumes. Calculate the total volume of fluid in the piping system, then use the **Antifreeze Percentages by Volume** table to determine the amount of antifreeze needed. Check antifreeze concentration from a homogenized sample using a hydrometer or refractometer to measure specific gravity.

**Figure 2: Typical Closed Loop with Central Pumping (Shown with internal modulating water valve)**

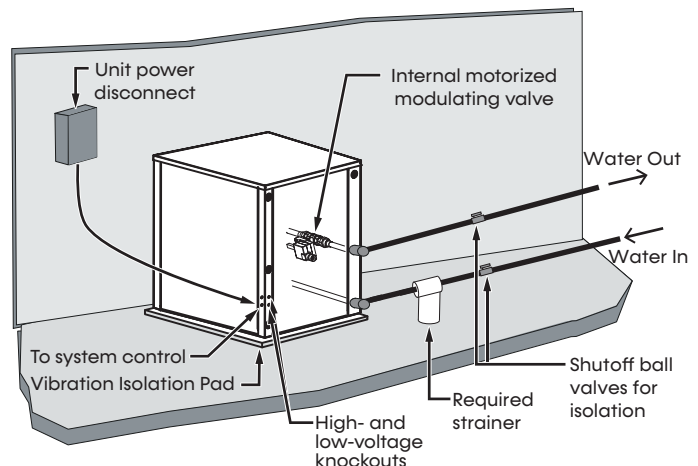

Models:  
MW  
036-120

# Ground-Loop Heat Pump Antifreeze Charging

## GROUND-LOOP ANTIFREEZE CHARGING

It is highly recommended to utilize premixed antifreeze fluid where possible to ensure proper concentration levels.

The following procedure is based on pure antifreeze and can be implemented during the Full Flush procedure after the loop piping is installed and ready to be flushed and filled. When using a premixed mixture of 15°F (-9.4°C) freeze protection, you can fill and flush the system with the premix directly to prevent handling pure antifreeze during installation.

### WARNING

Always use properly marked vehicles (D.O.T. placards), and clean/suitable/properly identified containers for handling flammable antifreeze mixtures. Post and advise those on the job site of chemical use and potential dangers of handling and storage

### WARNING

Always dilute alcohols with water (at least 50% solution) before using. Alcohol fumes are flammable and can cause serious injury or death if not handled properly.  
When handling methanol (or any alcohol), always wear eye protection and rubber gloves as alcohols are easily absorbed through the skin.

### CAUTION

Always obtain MSDS safety sheets for all chemicals used in ground loop applications including chemicals used as antifreeze.

### ATTENTION

DO NOT use automotive windshield washer fluid as antifreeze. Washer fluid contains chemicals that cause foaming.

**Table 1: Fluid Volume  
(gal [liters] per 100' [30 m] of Pipe)**

Pipe	Size (in)	Volume (gal) [liters]
Copper	1	4.1 [15.3]
	1.25	6.4 [23.8]
	2.5	9.2 [34.3]
Polyethylene	3/4 IPS SDR11	2.8 [1.4]
	1 IPS SDR11	4.5 [16.7]
	1.25 IPS SDR11	8.0 [29.8]
	1.5 IPS SDR11	10.9 [40.7]
	2 IPS SDR11	18.0 [67.0]
Fluid Cooler	036/060	7.4 [28.0]
Flush Cart Tank	10 dia x 3 ft tall [25.4 cm x 91.4 cm tall]	10.0 [37.9]

1. Flush the loop until all air is purged from system then pressurize to check for leaks before adding any antifreeze.
2. Run the discharge line to a drain and hook up an antifreeze drum to the suction side of the pump (if not adding below water level through approved container). Drain the flush cart reservoir down to the pump suction inlet so the reservoir can accept the volume of antifreeze.
3. Use the **Fluid Volume** table to calculate the total fluid volume of the loop. Next, calculate the amount of antifreeze needed using the **Antifreeze Percentage by Volume** table to determine appropriate freeze-protection level. Many southern applications require freeze protection because of piping exposed to ambient conditions.
4. Isolate the unit and prepare to flush only through loop. Start the flush cart and gradually introduce the required amount of liquid to the flush cart tank until attaining the proper antifreeze protection. Always introduce alcohols under water or use suction of pump to draw in directly to prevent fuming. The rise in flush reservoir level indicates amount of antifreeze added (some carts are marked with measurements in gallons or liters). A 10-inch-diameter (25.4 cm) cylinder, 3-feet (91.4 cm) tall holds approximately 8-gallons (30.3 liters) of fluid, plus the hoses, approximately two gallons (7.6 liters), which equals about 10 gallons (37.9 liters) total. If more than one tank full is required, immediately drain the tank by opening the waste valve of the flush cart. Note the color of the discharge fluid. Add food coloring to the antifreeze to help indicate where the antifreeze is in the circuit and prevent the dumping of antifreeze out the waste port. Repeat if necessary.

# Ground-Loop Heat Pump Antifreeze Charging

Models:  
MW  
036-120

## LOW WATER TEMPERATURE CUTOUT SETTING – DXM2.6

5. Take care when handling methanol (or any alcohol). Always wear eye protection and rubber gloves. Alcohol fumes are flammable and care should be taken with all flammable liquids. Open flush valves to flush through both the unit and the loop, then flush until fluid is homogeneous. It is recommended to run the unit in the heating and cooling mode for 15-20 minutes each to temper the fluid temperature and prepare it for pressurization. Use this period to clean the area. This procedure helps prevent the periodic “flat” loop condition.

6. Close the flush cart return valve then immediately close the flush cart supply valve, leaving a positive pressure in the loop of approximately 50 psi (345 kPa). Pressure check the system. Check the freeze protection of the fluid with the proper hydrometer to ensure that the correct amount of antifreeze is added to the system. Place the hydrometer into the flush reservoir then compare the reading to the following figures to determine the level of freeze protection:

- **Methanol Specific Gravity**
- **Propylene Glycol Specific Gravity**
- **Ethanol Specific Gravity**

Do not antifreeze more than a +10°F (-12.2°C) freeze point. Specific gravity hydrometers are available in the residential price list. Repeat after reopening and flushing for a minute to ensure a good second sample of fluid. Inadequate antifreeze protection can cause nuisance low temperature lockouts during cold weather.

7. Close the flush cart return valve then immediately close the flush cart supply valve and shut off the flush cart, leaving a positive pressure in the loop of approximately 50-75 psi (345-517 kPa).

When antifreeze is selected, clip the LT1 jumper (JW3) to select the low temperature (antifreeze 10°F [-12.2°C]) set point and avoid nuisance faults (see the Low Water Temperature Cutout Selection section in this manual).

**Figure 3: LT1 Limit Setting**

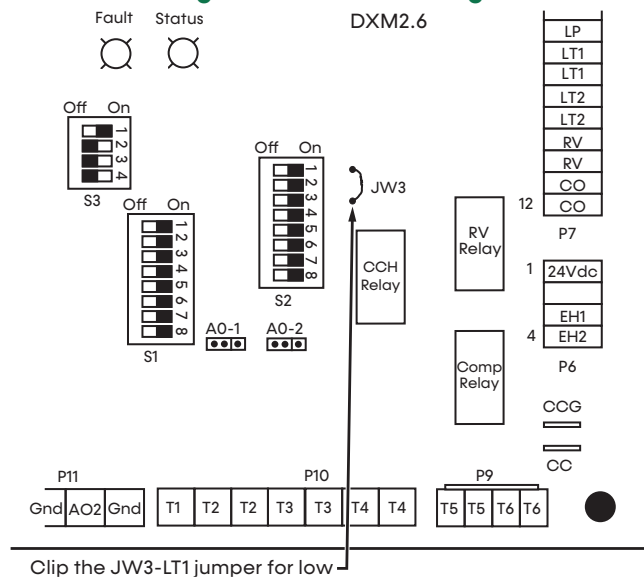

**Table 2: Antifreeze Percentages by Volume**

Type	Minimum Antifreeze Concentration % for Low Temperature Protection			
	10°F [-12.2°C]	15°F [-9.4°C]	20°F [-6.7°C]	25°F [-3.9°C]
Methanol	21%	17%	13%	9%
100% USP food grade Propylene Glycol	29%	24%	19%	12%
Ethanol <sup>1</sup>	28%	24%	18%	12%

1. Must not be denatured with any petroleum based product

Models:  
MW  
036-120

# Ground-Loop Heat Pump Antifreeze Charging

**Figure 4: Methanol Specific Gravity**

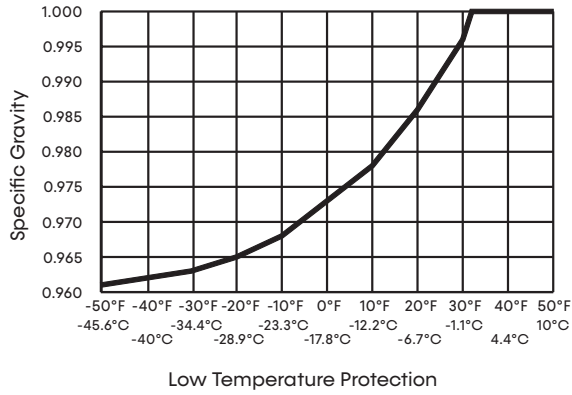

**Figure 5: Propylene Glycol Specific Gravity**

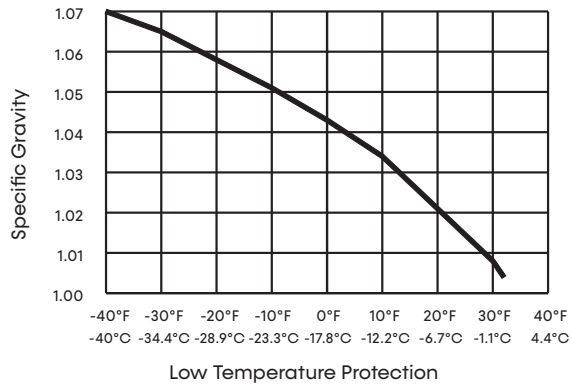

**Figure 6: Ethanol Specific Gravity**

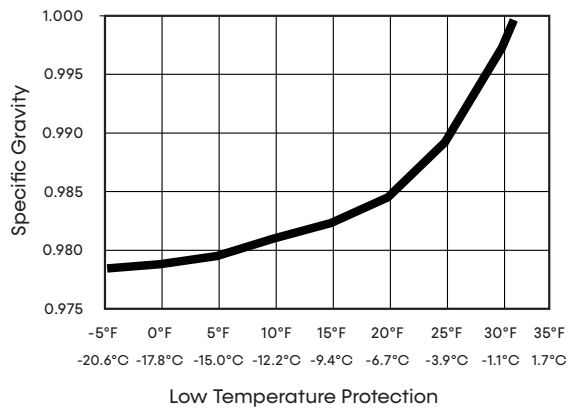

# Applications

## Ground-Water Heat Pump

Models:  
MW  
036-120

### GENERAL INFORMATION

For open-loop or ground-water applications, installing an intermediate heat exchanger to isolate an open loop from the heat-pump loop is required. In ground-water situations with heavy scaling or where biological growth such as iron bacteria is present, a closed-loop system is recommended. Over time intermediate heat exchangers may lose heat-exchange capabilities due to a build up of mineral deposits inside. Only qualified service mechanics can provide cleaning services as acid and special pumping equipment are required.

Include shutoff valves for easy servicing. "Tee" boiler drains or other valves into the line to allow for acid flushing of the intermediate heat exchanger. Use pressure temperature plugs for easy flow and temperature measurement. Limit supply and return water piping materials to copper, PE, or similar material. Never use PVC or CPVC as they are incompatible with the POE oils used in R-454B products and piping-system failure and property damage may occur.

Ensure water quantity is plentiful and of good quality. See Water Quality Requirements for water quality guidelines.

### EXPANSION TANK AND PUMP

Use a closed, bladder-type expansion tank to minimize mineral formation due to air exposure. Size the expansion tank to handle at least one minute of pump runtime using its drawdown capacity rating to prevent premature pump failure. Discharge water from the unit is not contaminated in any manner and can be disposed of in various ways depending on local building codes; i.e. recharge well, storm sewer, drain field, adjacent stream or pond, etc. Most local codes forbid the use of sanitary sewer for disposal. Consult your local building and zoning department to assure compliance in your area.

#### WARNING

Polyolester Oil, commonly known as POE oil, is a synthetic oil used in many refrigeration systems including those with R-454B refrigerant. POE oil, if it ever comes in contact with PVC or CPVC piping, may cause failure of the PVC/CPVC. PVC/CPVC piping should never be used as supply or return water piping with water-source heat pump products containing R-454B as system failures and property damage may result.

#### CAUTION

Low temperature limit systems do not allow leaving load water temperature (cooling mode) or leaving source water temperature (heating mode) to be below 42°F (5.6°C).

### WATER CONTROL VALVE

Note the placement of the water control valve. Always maintain water pressure in the heat exchanger by placing water control valves at the outlet of the unit to prevent mineral precipitation. Pilot-operated or slow-closing solenoid valves are recommended to reduce water hammer. If water hammer persists, mount a mini expansion tank on the piping to help absorb the excess hammer shock. Ensure that the unit transformer accommodates the total VA draw of the valve. For example, the slow-closing valve draws up to 35VA. This can overload smaller 40 or 50VA transformers depending on the other controls employed. A typical pilot-operated solenoid valve draws approximately 15VA.

### FLOW REGULATION

Install on source in of the unit. Accomplish flow regulation by using one of the following methods.

1. Most water control valves have a built-in flow adjustment. Determine flow rate by measuring the pressure drop through the unit heat exchanger then compare to the **Brazed-Plate Water Pressure Drop** table. Since the pressure is constantly varying, you may need two pressure gauges. Adjust the water control valve until reaching the desired flow of 2.5 to 3 GPM per ton (2.0 to 2.6 l/m per kW).
2. Install a flow-control device. Flow-control devices are typically an orifice of plastic material that is designed to allow a specified flow rate. These are mounted on the outlet of the water control valve. Flow-control devices may produce a velocity noise, but you can reduce this noise by applying back pressure. Apply back pressure by slightly closing the leaving isolation valve of the well water system.

#### WARNING

Never jumper terminal "A" from DXM2.6 #1 to DXM2.6 #2 on multi-compressor/multi-control board units. For more information, see the motorized water valve wiring examples in electrical section of this IOM.

Models:  
MW  
036-120

# Applications Ground-Water Heat Pump

## Example Ground Water Heat-Pump Configuration

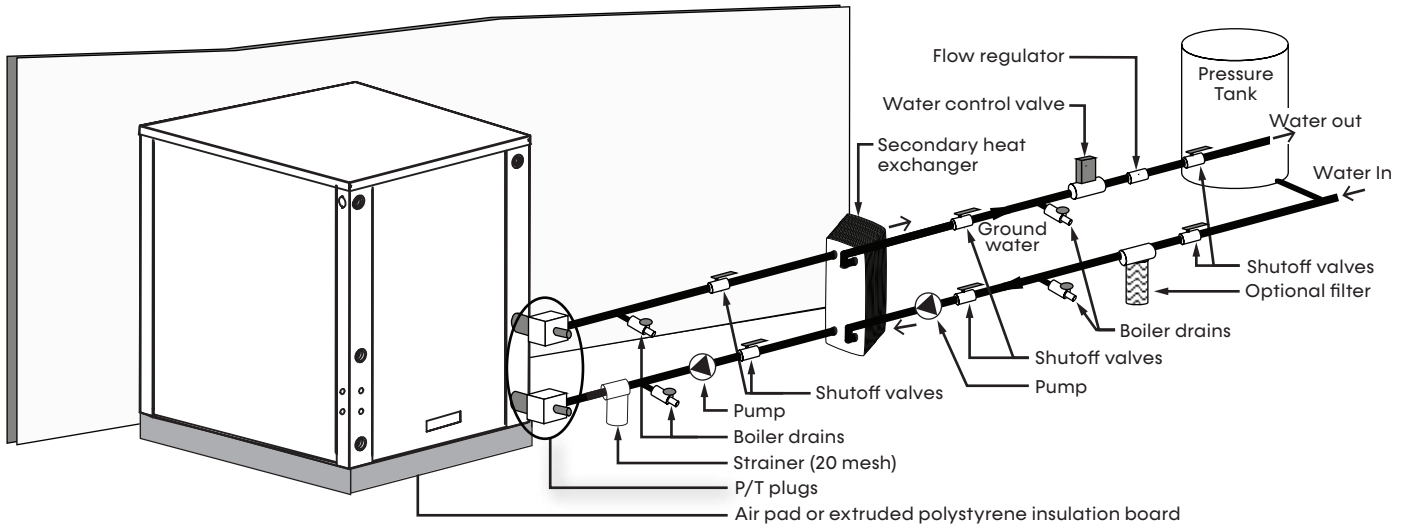

## SYSTEM FLUSHING - OPEN LOOP

For open loop systems with either internal flow control, modulating water valves, or external flow control, flush the system in a similar manner as closed loop systems. This is to ensure that all debris is removed from the system, eliminate air, and properly fill and charge with antifreeze (if necessary). Depending on configuration, any installed water control valves must be open during this process.

# Water Quality Requirements

**Table 3: Water Quality Requirements**

Clean water is essential to the performance and life span of water-source heat pumps. Contaminants, chemicals, and minerals all have the potential to cause damage to the water heat exchanger if not treated properly. All closed-loop water systems should undergo water quality testing and be maintained to the water quality standards listed in this table. All open-loop water systems shall be tested upon installation and periodically to ensure water quality standard in the table below are met.

Water Quality Requirements For Closed-Loop and Open-Loop Systems							
	Description	Symbol	Units	Heat Exchanger Type			
				Closed Loop Recirculating		Open Loop, Tower, Ground Source Well	
				All Heat Exchanger Types	Coaxial HX Copper Tube in Tube	Coaxial HX Cupronickel	Brazed- Plate HX 316 SS
Scaling Potential	pH - Chilled Water <85°F			7.0 to 9.0	7.0 to 9.0	7.0 to 9.0	7.0 to 9.0
	pH - Chilled Water >85°F			8.0 to 10.0	8.0 to 10.0	8.0 to 10.0	8.0 to 10.0
	Alkalinity	(HCO <sub>3</sub> <sup>-</sup> )	ppm - CaCO <sub>3</sub> equivalent	50 to 500	50 to 500	50 to 500	50 to 500
	Calcium	(Ca)	ppm	<100	<100	<100	<100
	Magnesium	(Mg)	ppm	<100	<100	<100	<100
	Total Hardness	(CaCO <sub>3</sub> )	ppm - CaCO <sub>3</sub> equivalent	30 to 150	150 to 450	150 to 450	150 to 450
	Langelier Saturation Index	LSI		-0.5 to +0.5	-0.5 to +0.5	-0.5 to +0.5	-0.5 to +0.5
	Ryznar Stability Index	RSI		6.5 to 8.0	6.5 to 8.0	6.5 to 8.0	6.5 to 8.0
Corrosion Prevention	Total Dissolved Solids	(TDS)	ppm - CaCO <sub>3</sub> equivalent	<1000	<1000	<1000	<1000
	Sulfate	(SO <sub>4</sub> <sup>2-</sup> )	ppm	<200	<200	<200	<200
	Nitrate	(NO <sub>3</sub> <sup>-</sup> )	ppm	<100	<100	<100	<100
	Chlorine (free)	(Cl)	ppm	<0.5	<0.5	<0.5	<0.5
	Chloride (water < 80°F)	(Cl <sup>-</sup> )	ppm	<20	<20	<150	<150
	Chloride (water > 120°F)	(Cl <sup>-</sup> )	ppm	<20	<20	<125	<125
	Hydrogen Sulfide <sup>a</sup>	(H <sub>2</sub> S)	ppb	<0.5	<0.5	<0.5	<0.5
	Carbon Dioxide	(CO <sub>2</sub> )	ppm	0	<50	10 to 50	10 to 50
	Iron Oxide	(Fe)	ppm	<1.0	<1.0	<1.0	<0.2
	Manganese	(Mn)	ppm	<0.4	<0.4	<0.4	<0.4
	Ammonia	(NH <sub>3</sub> )	ppm	<0.05	<0.1	<0.1	<0.1
	Chloramine	(NH <sub>2</sub> CL)	ppm	0	0	0	0
	Fouling & Biological	Iron bacteria		cells/mL	0	0	0
Slime-forming bacteria			cells/mL	0	0	0	0
Sulfate-reducing bacteria			cells/mL	0	0	0	0
Suspended Solids <sup>b</sup>		(TSS)	ppm	<10	<10	<10	<10
Electrolysis All HX types	Earth Ground Resistance <sup>x</sup>		Ohms	Consult NEC and local electrical codes for grounding requirements			
	Electrolysis Voltage <sup>d</sup>		mV	Measure voltage and internal water loop to HP ground			
	Leakage Current <sup>d</sup>		mA	Measure current in water loop pipe			
	Building Primary Electrical Ground to unit, must meet local diameter and penetration length requirements. Do not connect heat pump to steel pipe unless dissimilar materials are separated by using Di-electric unions. Galvanic corrosion of heat pump water pipe will occur						

Models:  
MW  
036-120

## Water Quality Requirements

1. The **Water Quality Requirements** table provides water quality requirements for coaxial and brazed-plate heat exchangers.
2. The water must be evaluated by an independent testing facility comparing site samples against this table. When water properties are outside of these parameters, the water must either be treated by a professional water treatment specialist to bring the water quality within the boundaries of this specification, or an external secondary heat exchanger must be used to isolate the heat pump water system from the unsuitable water. Failure to do so will void the warranty of the heat pump system and will limit liability for damage caused by leaks or system failure.
3. Regular sampling, testing and treatment of the water is necessary to assure that the water quality remains within acceptable levels thereby allowing the heat pump to operate at optimum levels.
4. If closed-loop systems are turned off for extended periods, water samples must be tested prior to operating the system.
5. For optimal performance, it is recommended that the closed-loop piping systems are initially filled with deionized water.
6. Well water with chemistry outside of these boundaries, and salt water or brackish water requires an external secondary heat exchanger. Surface/Pond water should not be used.
7. If water temperature is expected to fall below 40°F (4.4°C), antifreeze is required. Refer to the heat pump IOM for the correct solution ratios to prevent freezing.
  - α Hydrogen sulfide has an odor of rotten eggs. If one detects this smell, a test for H<sub>2</sub>S must be performed. If H<sub>2</sub>S is detected above the limit indicated, remediation is necessary. Consult with your water testing/treatment professional. If a secondary heat exchanger is required, use appropriate materials as recommended by the heat exchanger supplier.
  - β Suspended solids and particulates must be filtered to prevent fouling and failure of heat exchangers. Strainers or particulate filters must be installed to provide a maximum particle size of 600 micron (0.60 mm, 0.023 inch) using a 20 to 30 mesh screen size. When a loop is installed in areas with fine material such as sand or clay, further filtration is required to a maximum of 100 micron. Refer to the Strainer / Filter Sizing Chart to capture the particle sizes encountered on the site.
  - χ The WSHP piping system or other plumbing pipes must not be used as the building ground. An electrical grounding system using a dedicated ground rod meeting NEC and local electrical codes must be installed.
  - δ Refer to the **Antifreeze Percentages by Volume** table for instructions on measuring resistance and leakage currents within water loops.

**Strainer / Filter Sizing**

Mesh Size	Particle Size		
	Microns	Millimeter	Inch
20	840	0.840	0.0340
30	533	0.533	0.0210
60	250	0.250	0.0100
100	149	0.149	0.0060
150	100	0.100	0.0040
200	74	0.074	0.0029

- ppm = parts per million
- ppb = parts per billion

# Water Quality Requirements

## Measuring Electrolysis, Voltage, and Current for Ground-Water Applications

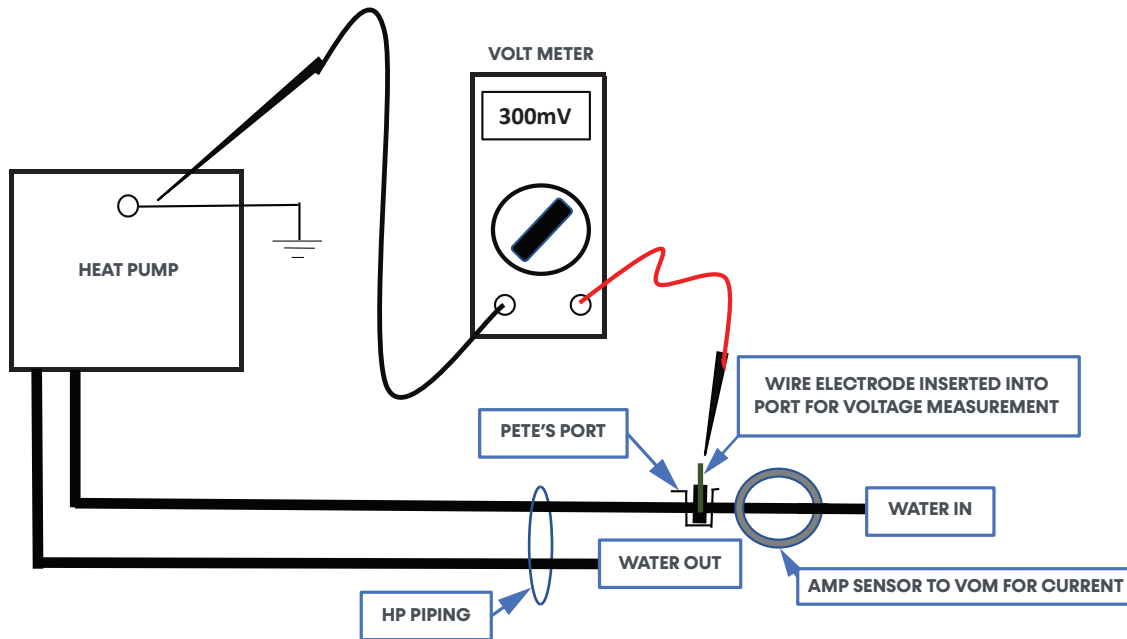

- Measure the electrolysis voltage using a volt meter between the heat pump ground and a #14 AWG solid copper wire electrode inserted into the water using a Pete's style access port.
- The heat pump must be operating and the water stream flowing.
- The voltage measured should be less than 300mV (0.300V). If the voltage is higher than 500mV, electrolysis occurs resulting in corrosion.
- If voltage is measured, the cause is a high-resistance earth ground or current on the neutral conductor. Remedial measures should be performed.
- Measure the current flowing through the piping system by using an amp clamp probe on the water-in line. The heat pump must be operating and the water stream flowing.
- There should be zero amps measured. If current is present, there is leakage current to the plumbing system and it must be rectified to prevent pipe corrosion.

## Measuring Earth Ground Resistance

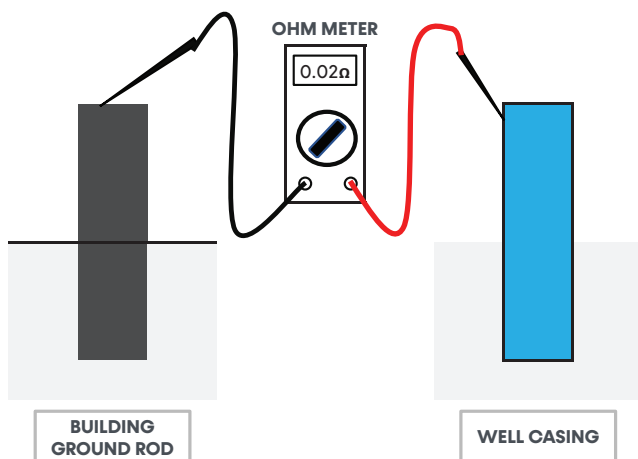

- Measure the earth ground bond using an Ohm meter between the building's ground rod and the steel well casing.
- The resistance measured should be zero Ohms. The NEC allows a resistance to ground up to 20 Ohms. Any resistance above zero indicates a poor earth ground, which may be the result of a hot neutral line or that conductive water is present. Both of these may lead to electrolysis and corrosion of the heat pump piping. A check for both should be performed and resolved.

**NOTE: If the well casing is plastic, create a conductive path by inserting a #6 AWG bare copper wire into the well water. Remove the temporary conductor when finished.**

Models:  
MW  
036-120

# Load Plumbing Configuration

## MW Unit Load Plumbing

The applications for the load side of the MW are too numerous to list all in this document, but some basic guidelines are presented in the following sections.

### Wide temperature variation applications such as heating/cooling coils:

- Employ piping materials that are rated for the maximum temperature and pressure combination. This excludes PVC for most heating applications.
- Ensure that load water flow in high temperature heating applications is at least 3 GPM per ton (3.9 l/m per kW) to improve performance and reduce nuisance high pressure faults.
- DO NOT employ plastic-to-metal threaded joints
- Utilize a pressure tank and air-separator vent system to equalize pressure and remove air.

### Swimming Pool and Hot Tub Applications:

- Isolate the load brazed plate with a secondary heat exchanger constructed of anti-corrosion material in all chlorine/bromine fluid applications.
- Corrosive fluids or other water that does not meet the water quality guidelines must never be run through the unit's internal brazed-plate heat exchangers.

### Potable Water Applications:

- Potable water systems require a field-supplied external secondary heat exchanger that is specifically designed for potable water applications.
- Ensure load water flow in high temperature heating applications is at least 3 GPM per ton to improve performance and reduce nuisance to high-pressure faults.

### System Flushing - Load Side

Flush load side piping in a similar manner to the source side piping. This is to ensure that all debris is removed from the system, eliminate air, and properly fill and charge with water and antifreeze (if necessary). Install flushing valves or other drain valves to facilitate this process. Depending on configuration, any installed water control valves (internal or external) must be open during this process.

**Figure 7: Load Piping Example #1  
No Buffer Tank, Direct to Load**

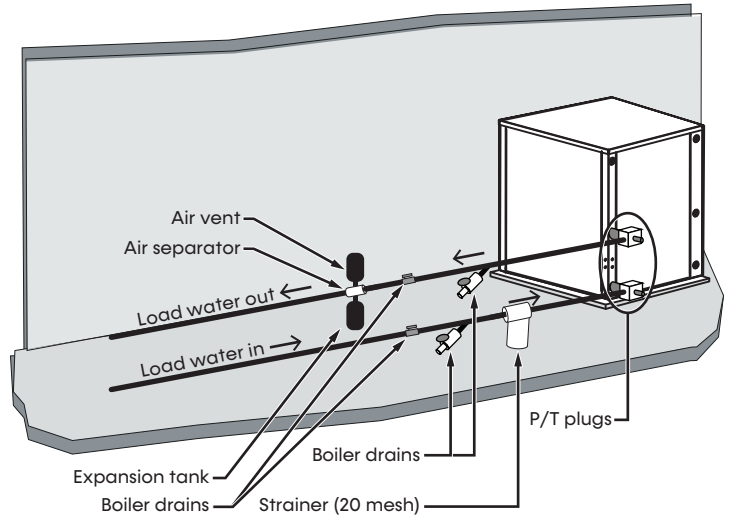

**Figure 8: Load Piping Example #2  
Buffer Tank**

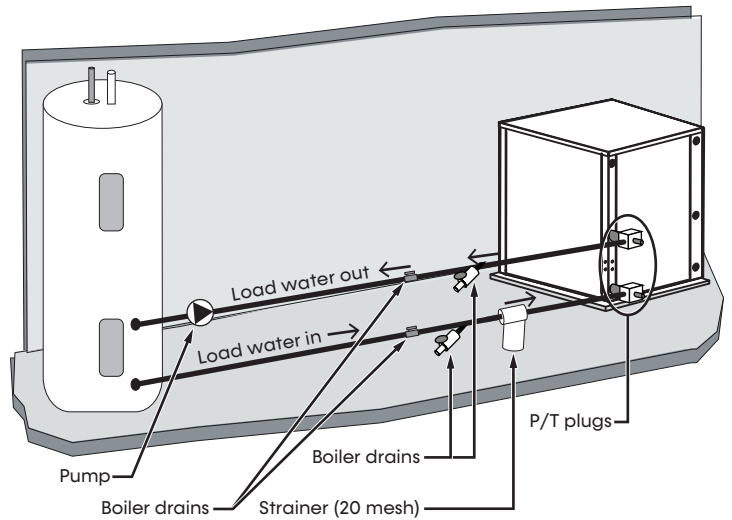

**NOTES**

- Connections to the buffer tank depend on the specific model selected

# Hot Water Generator

The Hot Water Generator (HWG) or desuperheater option provides considerable operating-cost savings by utilizing heat energy from the compressor discharge line to help satisfy domestic hot water requirements. The HWG is active throughout the year, providing virtually free hot water when the heat pump operates in the cooling mode or hot water at the COP of the heat pump during operation in the heating mode.

Heat pumps equipped with the HWG option include a built-in water-to-refrigerant heat exchanger that eliminates the need to tie into the heat pump's refrigerant circuit in the field. The **Typical HWG Installation** figure shows an example of HWG water piping connections on a unit with a field-supplied, externally mounted circulating pump. This piping layout prevents the HWG pump from pulling sludge/debris from the bottom of the tank. The temperature setpoint of the HWG is 125° (51.6°C).

In a typical 50-gallon two-element electric water heater, turn down the lower element to 100°F, or the lowest setting, to get the most from the HWG. The tank eventually stratifies so that the lower 80% of the tank, or 40 gallons, becomes 100°F (controlled by the lower element). The upper 20% of the tank, or 10 gallons, is maintained at 125°F (controlled by the upper element).

**⚠ WARNING**

A 150°F setpoint may lead to scalding or burns. The 150°F setpoint must only be used on systems that employ an approved anti-scald valve.

Using a 125°F setpoint, the HWG can heat the lower 40 gallons of water from 100°F to 125°F, providing up to 8,330 Btu's of heat.

Electric water heaters are recommended. If a gas, propane, or oil water heater is used, install a second preheat tank. See the **Two Tank HWG Installation** figure. If the electric water heater has only a single center element, the dual-tank system is recommended to ensure a usable entering water temperature for the HWG.

Typically, a single tank of at least 50 gallons (189 liters) is used to limit installation costs and space. For maximum storage and temperate source water to the HWG, use a dual tank system as shown in the **Two Tank HWG Installation** figure.

It is always advisable to use water-softening equipment on domestic water systems to reduce the scaling potential and lengthen equipment life. In extreme water conditions, it may be necessary to avoid the use of the HWG option since the potential cost of frequent maintenance may offset or exceed any savings. Use the **HWG Water Piping** table for scaling potential tests.

**Figure 9: Typical HWG Installation**

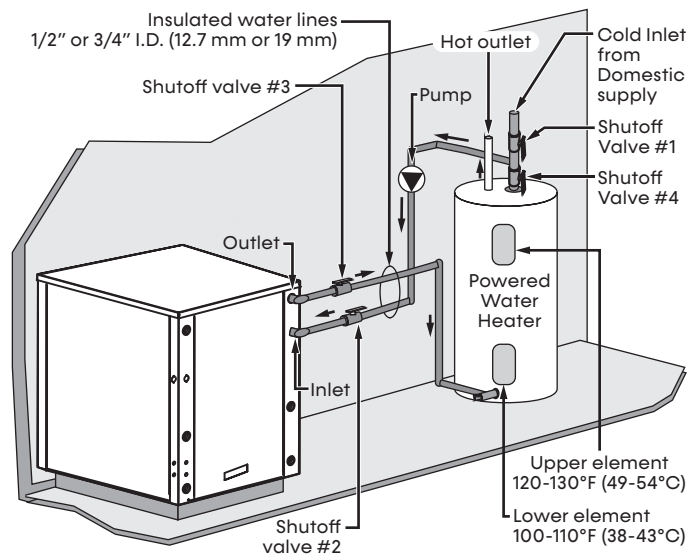

**Figure 10: Two Tank HWG Installation**

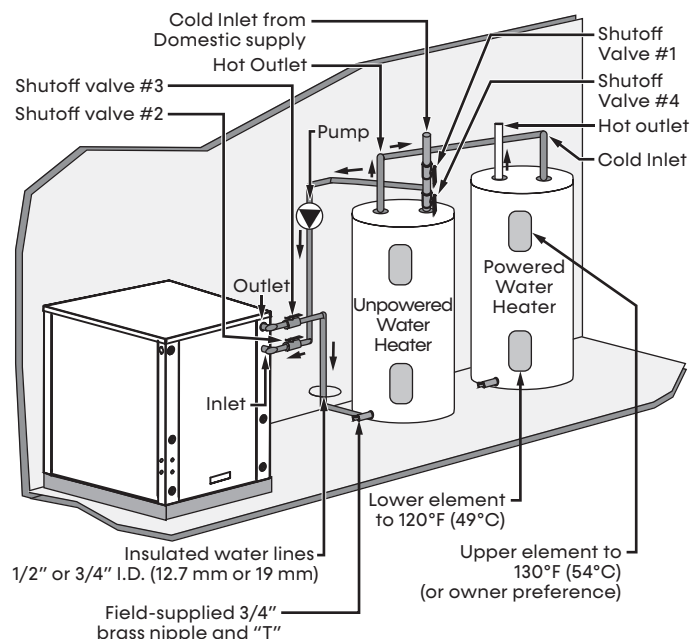

Models:  
MW  
036-120

# Hot Water Generator

## WARNING

Under no circumstances should the sensors be disconnected or removed. Full load conditions can drive hot water tank temperatures far above safe temperature levels if sensors are disconnected or removed.

## INSTALLATION

The HWG is controlled by two bi-metal temperature switches. One switch is located on the compressor discharge line to sense the discharge refrigerant temperature. The other switch is located on the HWG heat exchanger's "Water In" line to sense the potable water temperature. Power for the external circulating pump is wired as shown in the **HWG Wiring** figure.

The HWG operates any time the refrigerant temperature is sufficiently above the water temperature.

- **Discharge Temperature Switch:** Allows HWG operation at 135°F (57.2°C), and disengages HWG operation at 125°F (51.7°C).
- **Incoming Hot Water Temperature Switch:** Allows HWG operation at 115°F (46.1°C), and disengages HWG operation at 125°F (51.7°C).

Figure 11: HWG Wiring

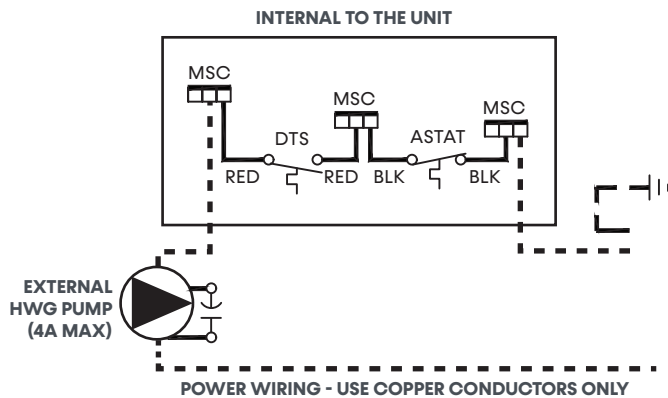

### LEGEND

DTS = DISCHARGE TEMPERATURE SWITCH  
ASTAT = INCOMING HOT WATER TEMPERATURE SWITCH  
MSC = MULTI-SPLICE CONNECTOR

**NOTE: Power for the external pump can be up to 277V.**

Install the heat pump, water piping, pump, and hot water tank where the ambient temperature does not fall below 50°F (10°C). Keep water piping lengths at a minimum. DO NOT use a one-way length greater than 50 feet (15 m). Reference the **HWG Water Piping** table for recommended pipe sizes and maximum lengths.

All installations must be in accordance with local codes. The installer is responsible for knowing the local requirements, and for performing the installation accordingly. DO NOT power the HWG pump until *Initial Startup* section is complete. To avoid damaging the pump, do not power it before all installation steps are complete.

## WARNING

Using a 150°F setpoint for domestic hot water results in water temperatures sufficient to cause severe physical injury in the form of scalding or burns. A hot water setpoint of 150°F must only be used on systems that employ an approved anti-scald valve (part number (AVAS4) at the hot water storage tank with such valve properly set to control water temperatures distributed to all hot water outlets at a temperature level that prevents scalding or burns.

Figure 12: Anti-scald Valve Piping Connection

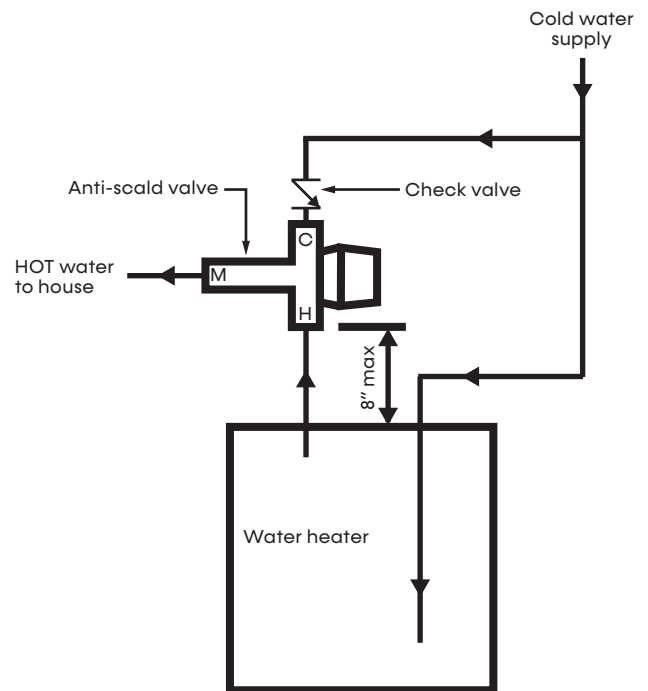

# Hot Water Generator

## WATER TANK PREPARATION

1. Turn off power or fuel supply to the hot water tank.
2. Connect a hose to the drain valve on the water tank.
3. Shut off the cold water supply to the water tank.
4. Open the drain valve and open the pressure relief valve or a hot water faucet to drain tank.
5. When using an existing tank, flush it with cold water after it is drained until the water leaving the drain hose is clear and free of sediment.
6. Close all valves and remove the drain hose.
7. Install HWG water piping and pump.

## HWG WATER PIPING

1. Route and install the water piping and valves using the recommended copper size given in the **HWG Water Piping** table. Use an appropriate method to purge air from the HWG piping. To purge, flush water through the HWG or install an air vent at the high point of the HWG piping system.
2. Insulate all HWG water piping with no less than 3/8-inch (10 mm) wall closed-cell insulation.
3. Open both shutoff valves and make sure the tank drain valve is closed.

## WATER TANK REFILL

1. Close valve #4. Ensure that the HWG valves (valves #2 and #3) are open. Open the cold water supply (valve #1) to fill the tank through the HWG piping. This forces water flow through the HWG and purges air from the HWG piping.
2. Open a hot water faucet to vent air from the system until water flows from faucet; turn off faucet. Open valve #4.
3. Depress the hot water tank pressure relief valve handle to ensure that there is no air remaining in the tank.
4. Inspect all work for leaks.
5. Before restoring power or fuel supply to the water heater, adjust the temperature setting on the tank thermostat(s) to ensure maximum utilization of the heat available from the refrigeration system and to conserve the most energy.

On tanks with both upper and lower elements and thermostats, turn down the lower element to 100°F (38°C) or the lowest setting; adjust the upper element to 120-130°F (49-54°C). Depending upon the specific needs of the customer, you may want to adjust the upper element differently. On tanks with a single thermostat, use a preheat tank.

6. Replace access cover(s) and restore power or fuel supply.

## INITIAL STARTUP

7. Make sure all valves in the HWG water circuit are fully open.
8. Turn on the heat pump and allow it to run for 10-15 minutes.
9. Apply power to the HWG pump.
10. The HWG pump will run if both the Discharge Temperature Switch and Incoming Hot Water Temperature Switch are at the appropriate temperatures.
11. The temperature difference between the water entering and leaving the HWG coil should be approximately 5-10°F (3-6°C).
12. Allow the unit to operate for 20 to 30 minutes to insure that it is functioning properly.

**Table 4: HWG Water Piping**

Unit Nominal Tonnage	Nominal HWG Flow (gpm)	1/2" Copper (max length <sup>1</sup> )	3/4" Copper (max length <sup>1</sup> )
2.0	0.8	50	-
2.5	1.0	50	-
3.0	1.2	50	-
3.5	1.4	50	-
4.0	1.6	45	50
5.0	2.0	25	50
6.0	2.4	10	50

1. The maximum length is equivalent length (in feet) one way of type L copper.

### WARNING

Use only copper piping for HWG piping due to the potential of high water temperatures for water that has been in the HWG heat exchanger during periods of no-flow conditions (HWG pump not energized). Piping other than copper may rupture due to high water temperature and potable water pressure. Do not use CPVC, PEX, or other plastic pipe for HWG piping

Models:  
MW  
036-120

## Electrical Data

### Standard Unit

Unit Size	Rated Voltage	Voltage Code	Voltage Min/Max	Compressor			Total Unit FLA	Min Circuit Amp	Fuse HACR Amp
				RLA	LRA	Qty			
MW036	208/230-1-60	G.J.	187/252	14.6	76.0	1	14.6	18.3	30
	265/60/1	E.D	249/291	10.2	55.0	1	10.2	12.8	20
	208/230-3-60	H.K.	187/252	8.6	70.0	1	8.6	10.8	15
	460-3-60	F.L.	432/504	4.5	39.0	1	4.5	5.6	15
MW060	208/230-1-60	G.J.	187/252	22.3	149.0	1	22.3	27.9	50
	208/230-3-60	H.K.	187/252	14.0	150.0	1	14.0	17.5	30
	460-3-60	F.L.	432/504	6.3	58.0	1	6.3	7.9	15
MW120	208/230-1-60	G.J.	187/252	23.7	157.0	2	47.4	53.3	70
	208/230-3-60	H.K.	187/252	16.0	156.4	2	32.0	36.0	50
	460-3-60	F.L.	432/504	7.1	69.0	2	14.2	16.0	20

# Electrical Power Wiring

Models:  
MW  
036-120

## ⚠ WARNING

To avoid possible injury or death due to electrical shock, open the power supply disconnect switch and secure it in an open position during installation.

## ⚠ WARNING

Disconnect electrical power source to prevent injury or death from electrical shock.

## ⚠ CAUTION

Use only copper conductors for field installed electrical wiring. Unit terminals are not designed to accept other types of conductors.

## ELECTRICAL

**Line Voltage** - All field installed wiring, including electrical ground, must comply with NFPA 70: National Electrical Code (NEC), CSA C22.1: Canadian Electrical Code (CE Code), as well as applicable local codes. Refer to the unit electrical data for fuse sizes. Consult wiring diagram for field connections that must be made by the installing (or electrical) contractor. All final electrical connections must be made with a length of flexible conduit to minimize vibration and sound transmission to the building.

**Disconnects** - Units with a factory-installed disconnect switch will provide full separation of **all poles** and disconnection from main line voltage. For units where factory disconnect is not selected as an option, the installer must incorporate the means to fully disconnect the line voltage in the fixed wiring in accordance with wiring rules and local electrical codes.

## POWER CONNECTION

The line voltage connection is made by connecting the incoming line voltage wires to the “L” side of the contactor. See the electrical data tables for maximum fuse sizes.

## GENERAL LINE VOLTAGE WIRING

Ensure the available power is the same voltage and phase shown on the unit serial plate. Line- and low-voltage wiring must be in accordance with local codes or the National Electric Code, whichever is applicable.

Figure 13: Single Phase Line Voltage Field Wiring

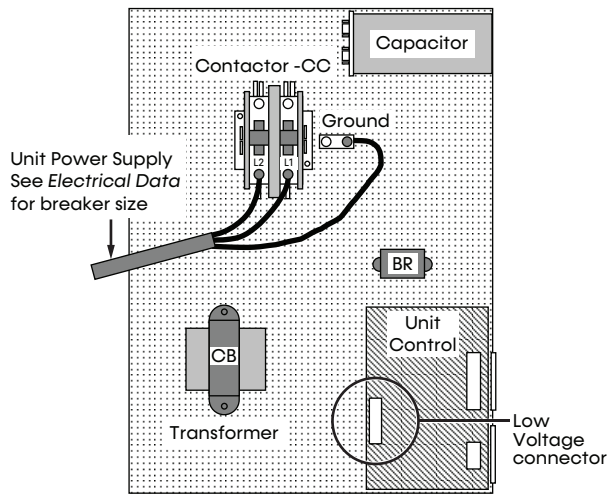
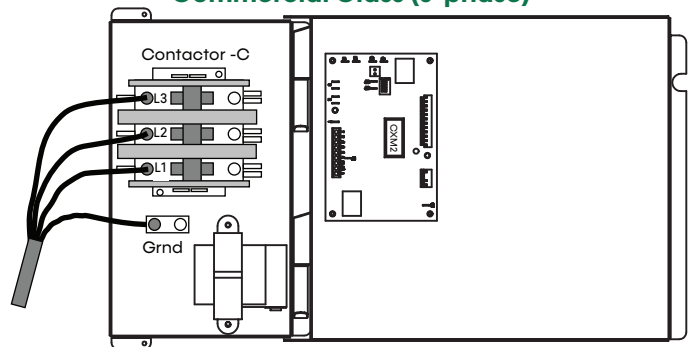

Figure 15: 036-060 Line Voltage Field Wiring Commercial Class (3-phase)



## TRANSFORMER

All 208/230V units are factory wired for 208V. If supply voltage is 240V, the installer must rewire the transformer. See the example wiring diagram for specific instructions.

Models:  
MW  
036-120

# Electrical Example Wiring Diagram

**NOTE: See the DXM2.6 AOM (part #97B0003N13) or MPC Controller AOM (part #97B0031N01).**

**Figure 16: Example Wiring Diagram for MW036-060**

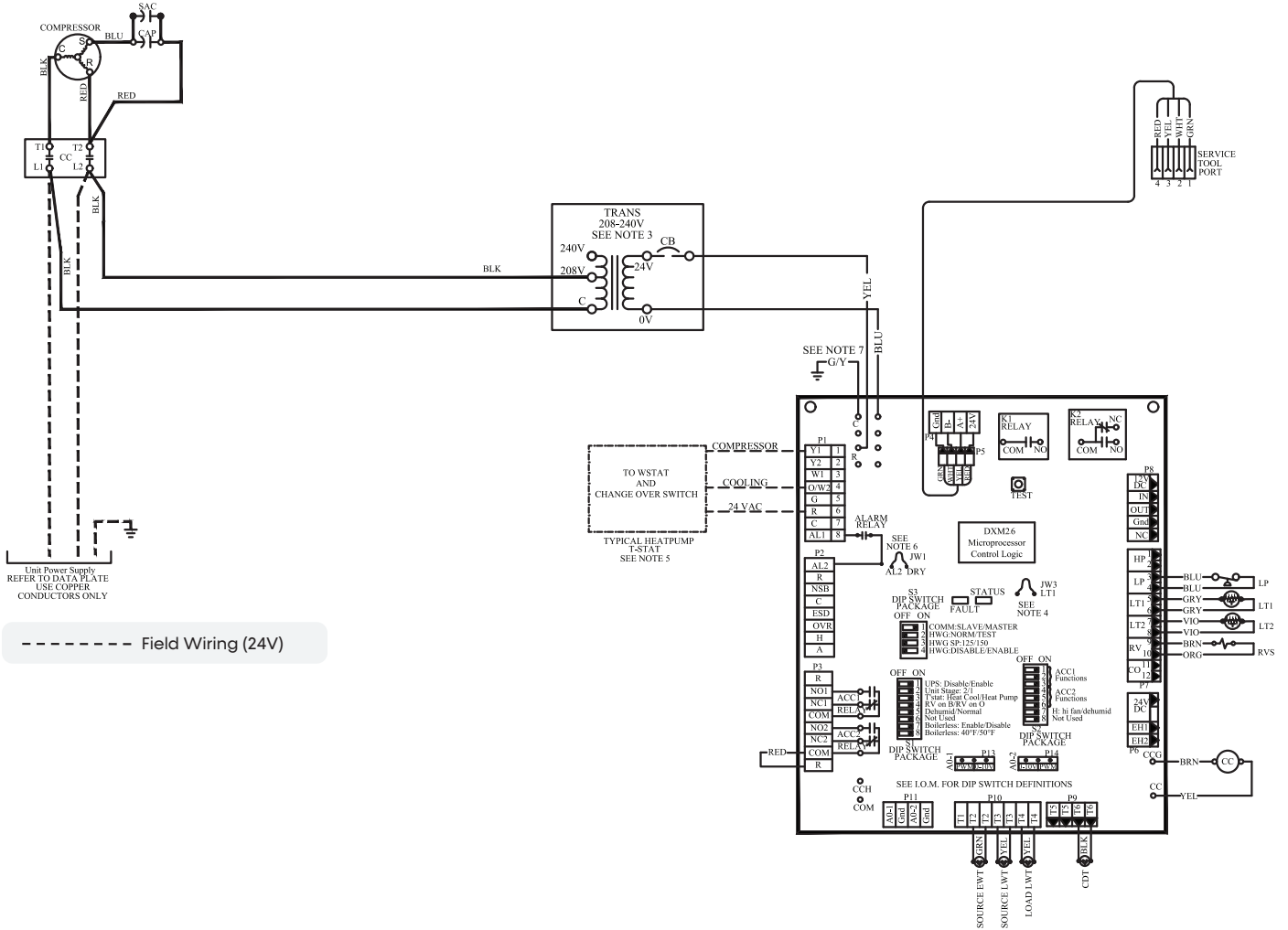

# Electrical Example Wiring Diagram

Models:  
MW  
036-120

**WARNING**

Never jumper terminal "A" from DXM2.6 #1 to DXM2.6 #2 on multi-compressor/multi-control board units. For more information, see the motorized water valve wiring examples in electrical section of this IOM.

**NOTE:** See the DXM2.6 AOM (part #97B0003N13) or MPC Controller AOM (part #97B0031N01).

**Figure 17: Example Wiring Diagram for MW120**

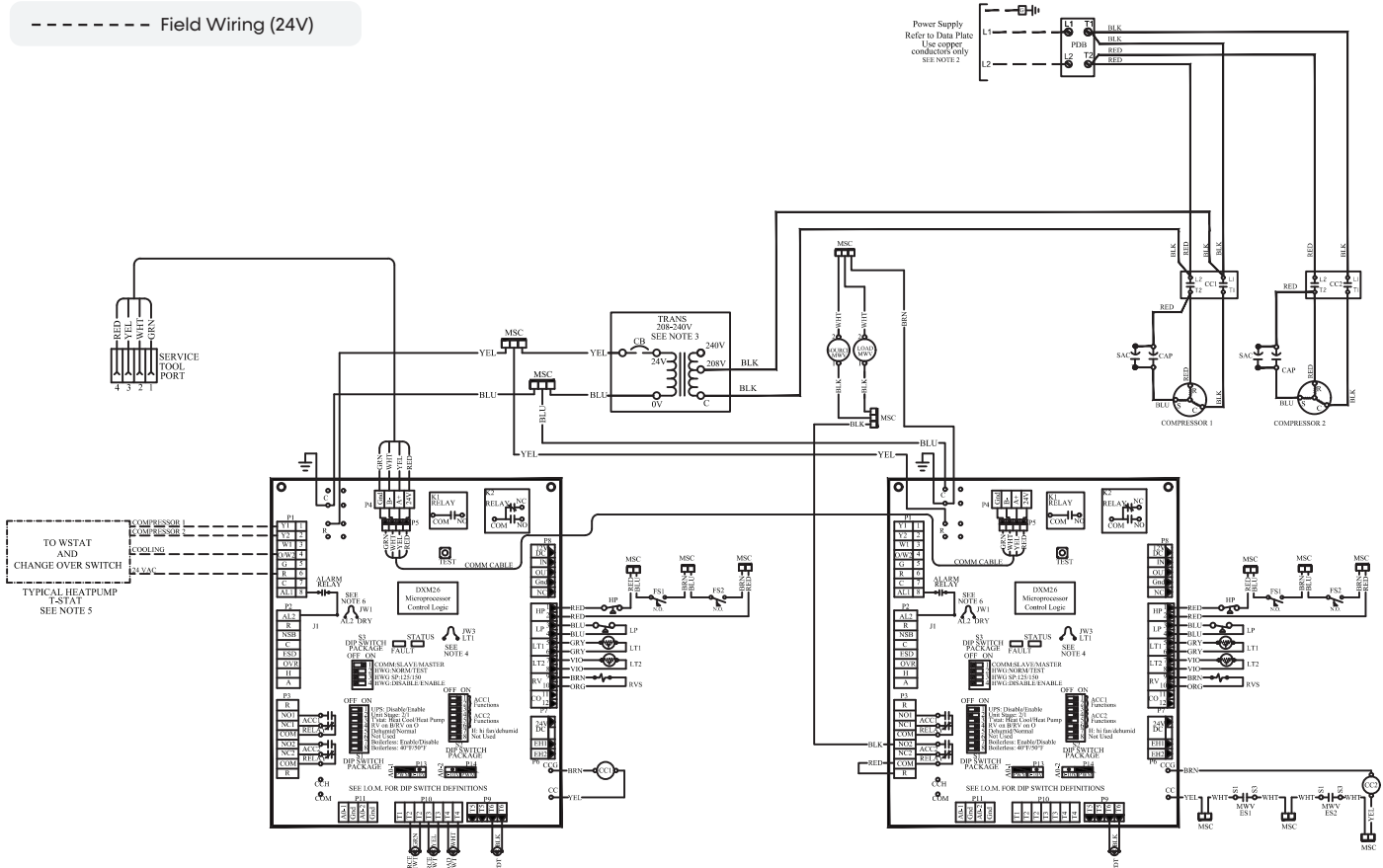

Models:  
MW  
036-120

# Electrical Low-Voltage Wiring

## THERMOSTAT CONNECTIONS

Wire the thermostat directly to the DXM2.6. See *Electrical Thermostat Wiring* for specific terminal connections. Review the appropriate AOM (Application, Operation and Maintenance) manual for units with DDC controls.

## LOW WATER TEMPERATURE CUTOUT SELECTION

The unit control allows the field selection of low water (or water-antifreeze solution) temperature limit by clipping jumper JW3 (see the **LT1 Limit Setting** figure), which changes the sensing temperature associated with thermistor LT1. Note that the LT1 thermistor is located on the refrigerant line between the brazed-plate heat exchanger and expansion device (TXV). LT1 senses refrigerant temperature, not water temperature, which is a better indication of how water flow rate/temperature is affecting the refrigeration circuit. The factory setting for LT1 is for systems using water (30°F [-1.1°C] refrigerant temperature). In low water temperature (extended range) applications with antifreeze (most ground loops), clip jumper JW3 as shown in the **LT1 Limit Setting** figure to change the setting to 10°F (-12.2°C) refrigerant temperature, which is a more suitable temperature when using an antifreeze solution. All of the manufacturer’s units operating with entering water temperatures below 60°F (15.6°C) require the optional water/refrigerant circuit insulation package to prevent internal condensation.

## Variable Water Flow FREEZE PROTECTION

Variable Water Flow freeze protection logic is designed to safeguard the brazed-plate heat exchanger (BPHE) from freeze-related damage. The system and a flow-proving switch monitor the source loop leaving water temperature (LWT) and initiates a lockout if it approaches a threshold where freezing may begin.

To mitigate this risk, the control logic includes a freeze protection setpoint that triggers a lockout condition when necessary. While antifreeze is strongly recommended in low-temperature loop designs, the lockout feature acts as a critical backup to prevent slush or freezing water from entering the heat exchanger under fault or marginal conditions.

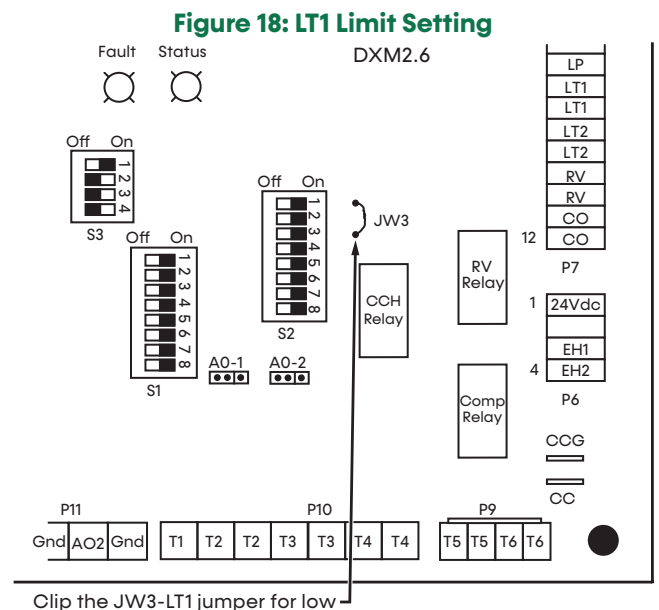

# Electrical Low-Voltage Wiring

Models:  
MW  
036-120

## ACCESSORY CONNECTIONS

A terminal paralleling the compressor contactor coil is provided on the DXM2.6. Terminal “A” is designed to control accessory devices, such as water valves. **NOTE: Only use this terminal with 24V signals and not line voltage.** Terminal “A” is energized with the compressor contactor. See the Accessory Wiring figure or the specific unit wiring diagram for details.

**Table 5: Low Voltage VA Ratings**

Component	VA
Typical Blower Relay	6 - 7
Typical Reversing Valve Solenoid	4 - 6
30 A Compressor Contactor	6 - 9
Subtotal	16 - 22
+ DXM2.6 (8 - 12VA) <sup>1</sup>	24 - 34
Remaining VA for Accessories	41 - 51

1. Optional DXM2.6 and/or DDC controls include a 75VA transformer.

**Figure 19: Accessory Wiring**

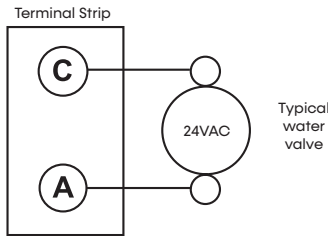

## WATER SOLENOID VALVES

Use an external solenoid valve(s) on ground water installations to shut off flow to the unit when the compressor is not operating. A slow closing valve may be required to help reduce water hammer. The **Accessory Wiring** figure shows typical wiring for a 24VAC external solenoid valve. The following figures illustrate a slow-closing water control valve wiring for two styles of typical accessory water valves.

- **Accessory Motorized Water Valve – Typical Wiring Example #1**
- **Accessory Motorized Water Valve – Typical Wiring Example #2**

Slow-closing valves take approximately 60 seconds to open (very little water flows before 45 seconds). Once fully open, an end switch allows the compressor to be energized. Only use relay or triac-based electronic thermostats with slow-closing valves. When wired as shown, the slow-closing valve will operate properly with the following notations:

1. The valve will remain open during a unit lockout.
2. The valve will draw approximately 25-35VA through the “Y” signal of the thermostat.

Models:  
MW  
036-120

# Electrical Low-Voltage Wiring

**NOTE:** This valve can overheat the anticipator of an electromechanical thermostat. Use only relay or triac-based thermostats.

**Figure 20: Accessory Motorized Water Valve – Typical Wiring Example #1**

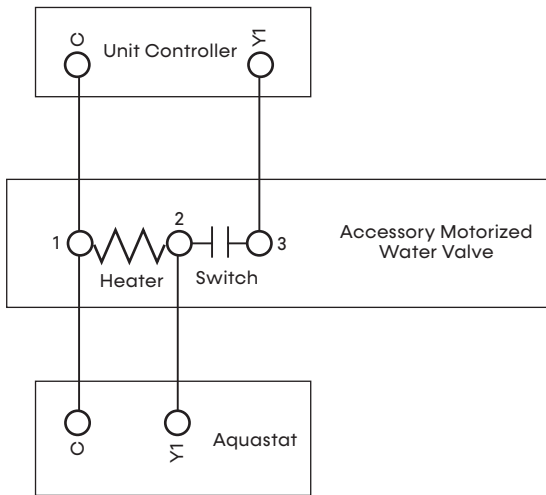

**Figure 21: Accessory Motorized Water Valve - Typical Wiring Example #2**

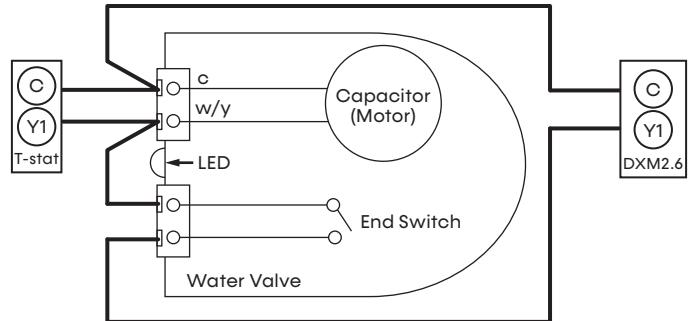

**Figure 22: Two-Stage Piping**

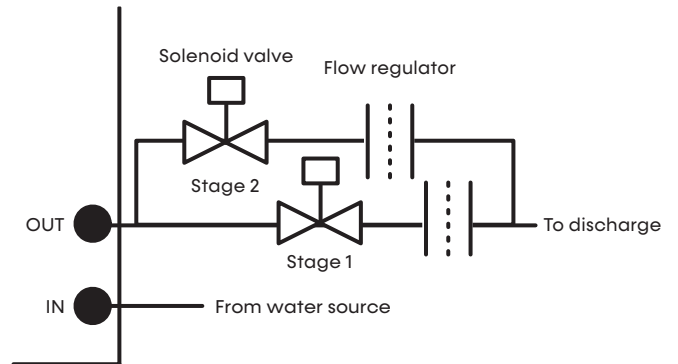

**NOTES**

Shutoff valves, strainers, and other required components not shown.

# Electrical Thermostat Wiring

Models:  
MW  
036-120

## THERMOSTAT INSTALLATION

You can control the MW Series in a variety of different ways depending on the application.

### Buffer Tank:

- **Aquastat - 24V two-heat, two-cool:** The aquastat maintains the tank setpoint by commanding the unit. The internal pump circulates fluid between the unit and the buffer tank if equipped, or commands the external pump to engage.

### Direct Space Control:

- **Thermostat - 24V two-heat, two-cool:** Thermostat will initiate space heating or cooling to maintain setpoint by commanding the unit. Internal pump will circulate fluid between the unit and the space (either radiant system or fan coils) if equipped, or command external pump to engage.

For direct space control, there are two set points that are used for control.

- **Space temperature - Comfort control.**
- **Leaving Water Temperature (LWT) - Unit control.**  
Configure this set point through the Wireless Service Tool.

Install thermostats used for space conditioning on an interior wall in a larger room, away from supply duct drafts. DO NOT locate the thermostat in areas subject to sunlight, drafts or on external walls. The wire access hole behind the thermostat may need to be sealed to prevent erroneous temperature measurement.

Position the thermostat back plate against the wall so that it appears level and so the thermostat wires protrude through the middle of the back plate.

Mark the position of the back plate mounting holes and drill holes with a 3/16-inch (5 mm) bit. Install supplied anchors and secure plate to the wall. Thermostat wire must be 18 AWG wire. Use the figures below for reference, however, use the thermostat IOM and or unit wiring diagram for actual wiring connections. Most heat pump thermostats are compatible provided they have the correct number of heating and cooling stages.

**Figure 23: Conventional 2 Heat / 2 Cool Aquastat Connection to DXM2.6**

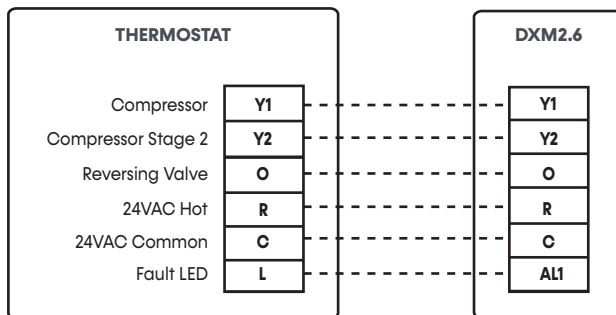

Models:  
MW  
036-120

# Electrical Refrigerant Detection System

## REFRIGERANT DETECTION SYSTEM (RDS)

The function, operation, and required servicing measures for the Refrigerant Detection System (RDS) include the following:

- The RDS monitors the status of the refrigerant sensor(s) in the unit. If refrigerant is detected above the maximum threshold, the control disables the compressor(s) and enables the pilot relay on the RDS control board. You can use this relay to open external zoning dampers and/or activate external mechanical ventilation. The relay is normally closed (NC) and can control a signal with a maximum of 28VA @ 24VAC.
- A fault is enabled if the RDS control board loses communication with a refrigerant sensor or if the main control board loses communication with the RDS board. See Functional Troubleshooting for steps to troubleshoot the RDS.

Figure 25: RDS Board

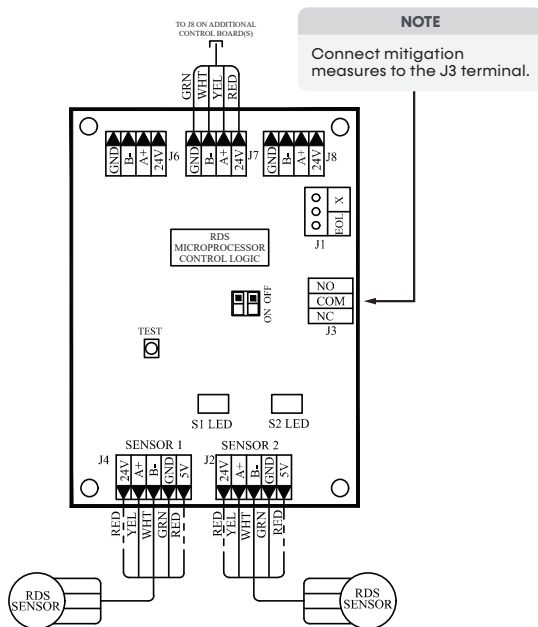

## FIELD-INSTALLED RDS SYSTEM

If the RDS was specified as a factory-installed option, but forgotten and not ordered, use the following guidelines to install a refrigerant detection sensor:

1. The sensor must be installed inside the cabinet
2. The ideal location for the sensor is on the exterior side panel of the controls enclosure as shown the **RDS Installation** figure
3. Because the RDS is optional, an area within the controls enclosure can house the RDS control board

### ATTENTION

The sensor cannot be installed in a way that exposes it to water and must be installed using the orientation displayed in the **RDS Installation** figure.

Figure 26: RDS Installation

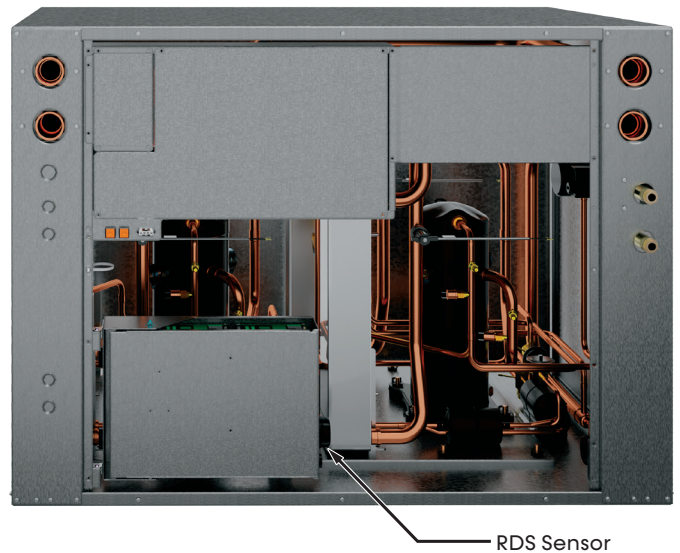
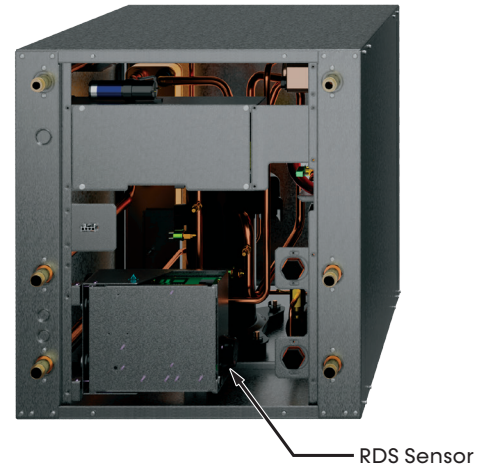

# Electrical

## DXM2.6, RDS, and Wireless Service Tool

Models:  
MW  
036-120

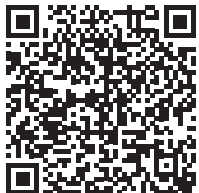

### **DXM2.6 Advanced Communicating Controls**

For detailed controller information, see the DXM2.6 Application, Operation, and Maintenance (AOM) manual (part # 97B0142N01). To confirm the controller type of your particular unit, refer to digit 9 on the unit model number and the unit nomenclature diagram found on page 3 of this manual.



### **Refrigerant Detection System**

For detailed controller information, see the Refrigerant Detection System Application, Operation, and Maintenance (AOM) manual (part # 97B0152N01).



### **Wireless Service Tool**

For detailed controller information, see the Wireless Service Tool Application, Operation, and Maintenance (AOM) manual (part # 97B0169N01). The Wireless Service Tool port is located on the corner post of most models.

Models:  
MW  
036-120

## Unit and System Checkout

### WARNING

Verify ALL water controls are open and allow water flow prior to engaging the compressor. Freezing of the brazed plate or water lines can permanently damage the heat pump.

### WARNING

To avoid equipment damage, DO NOT leave system filled in a building without heat during the winter unless antifreeze is added to system water. Condenser coils never fully drain by themselves and will freeze unless winterized with antifreeze.

### WARNING

Polyolester Oil, commonly known as POE oil, is a synthetic oil used in many refrigeration systems including those with R-454B refrigerant. POE oil, if it ever comes in contact with PVC or CPVC piping, may cause failure of the PVC/CPVC. PVC/CPVC piping should never be used as supply or return water piping with water-source heat pump products containing R-454B as system failures and property damage may result.

**NOTE: The manufacturer strongly recommends pressure testing all piping connections, both internal and external to the unit, using an appropriate method before finishing the interior space or before limiting access to all connections. Test pressure may not exceed the maximum allowable pressure for the unit and all components within the water system. The manufacturer is not responsible or liable for damages from water leaks due to inadequate or lack of a pressurized leak test, or damages caused by exceeding the maximum pressure rating during installation.**

BEFORE POWERING THE SYSTEM, check the following:

### UNIT CHECKOUT

- Balancing/Shutoff Valves:** Ensure all isolation valves are open, water control valves wired and open or brazed plate may freeze and burst.
- Line Voltage and Wiring:** Ensure Voltage is within an acceptable range for the unit and wiring and fuses/breakers are properly sized. Low voltage wiring is complete.
- Unit Control Transformer:** Ensure transformer has properly selected control voltage tap. 208-230V units are factory wired for 208V operation unless specified otherwise.
- Entering Water:** Ensure entering water temperatures are within the range detailed in the **Operating Limits** table.
- Low Water Temperature Cutout:** Verify low water temperature cut-out on DXM2.6 is properly set.

- Water Flow Balancing:** Verify inlet and outlet water temperatures on both Load and source are recorded for each heat pump upon startup. This check can eliminate nuisance trip outs and high velocity water flows that can erode heat exchangers.
- Unit Controls:** Verify DXM2.6 field-selection options are proper and complete.
- Strainers:** Verify 20 mesh (841 micron) [0.84mm] strainers are installed in load and source water piping. Confirm maintenance schedule for strainers.

### SYSTEM CHECKOUT

- System Water Temperature:** Check load and source water temperature for proper range and also verify heating and cooling setpoints for proper operation.
- System pH:** System water pH is 6 - 8.5. Proper pH promotes longevity of hoses and fittings.
- System Flushing:** Verify all hoses are connected end to end when flushing to ensure debris bypasses unit heat exchanger and water valves etc. Water used in the system must be potable quality initially and clean of dirt, piping slag, and strong chemical cleaning agents. Verify all air is purged from the system. Air in the system can cause poor operation or system corrosion.
- Standby Pumps:** Verify the standby pump is properly installed and in operating condition.
- System Controls:** Verify system controls function and operate in the proper sequence.
- Low Water Temperature Cutout:** Verify low water temperature cut-out controls are provided for the outdoor portion of the loop or operating problems occur.
- System Control Center:** Verify control center and alarm panel for proper setpoints and operation.
- Miscellaneous:** Note any questionable aspects of the installation.

# Unit Startup Procedure

## WARNING

When the disconnect switch is closed, high voltage is present in some areas of the electrical panel. Exercise caution when working with energized equipment.

1. It is recommended (but not necessary for startup) to plug in the Wireless Service Tool to the port on the corner post of the unit. You can check unit configuration and monitor operation during startup. Adjust all valves to their full open position. Turn on the line power to all heat pump units.
2. Operate each unit in the cooling cycle. Loop water temperature entering the heat pumps should be between 70°F (21°C) and 110°F (43°C).
3. Operate each heat pump in the heating cycle immediately after checking cooling cycle operation. A time delay prevents the compressor from re-starting for approximately five (5) minutes.
4. Establish a permanent operating record by logging the unit operating conditions at initial startup for each unit.
5. If a unit fails to operate, conduct the following checks:
  - A. Check the voltage and current. They should comply with the electrical specifications described on the unit nameplate.
  - B. Look for wiring errors. Check for loose terminal screws where wire connections are made on both the line- and low-voltage terminal boards.
  - C. Check the supply and return piping. They must be properly connected to the inlet and outlet connections on the unit.
  - D. If the checks described above fail to reveal the problem and the unit still will not operate, contact a trained service technician to ensure proper diagnosis and repair of the equipment.

**Table 6: Brazed-Plate Water Pressure Drop**

Model	GPM	Pressure Drop PSI			
		30°F	50°F	70°F	90°F
Source/Outdoor Brazed Plate					
MW036	4.5	1.7	1.3	1.0	0.8
	6.8	4.1	3.4	2.8	2.4
	9.0	7.1	6.0	5.1	4.5
MW060	7.5	1.5	1.3	1.1	0.9
	11.3	4.0	3.4	3.0	2.7
	15.0	6.9	6.2	5.5	5.0
MW120	15.0	1.7	1.4	1.2	0.9
	22.5	4.4	3.8	3.3	2.7
	30.0	7.6	6.8	6.1	5.0
Load/Outdoor Brazed Plate					
MW036	4.5	1.7	0.6	0.5	0.3
	6.8	4.1	1.4	1.3	1.1
	9.0	7.1	2.6	2.4	2.2
MW060	7.5	1.5	1.4	1.3	1.2
	11.3	4.0	3.5	3.2	3.0
	15.0	6.9	6.2	5.8	5.5
MW120	15.0	1.7	1.6	1.4	1.3
	22.5	4.4	3.8	3.5	3.3
	30.0	7.6	6.8	6.4	6.0

- Antifreeze is required for operation in the light grey area
- Operation in the dark grey area is not recommended

**NOTE: Units have a 5-minute time delay in the control circuit that can be bypassed on the DXM2.6 as shown below. See the DXM2.6 AOM for detailed features.**

### Test Mode Button

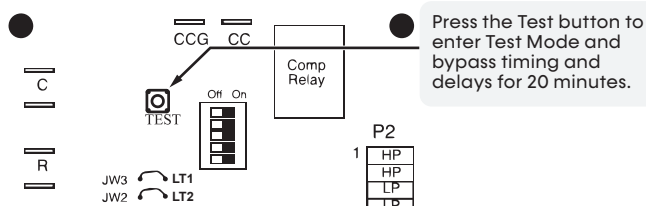

Models:  
MW  
036-120

## Unit Startup Procedure

**Table 7: Operating Limits**

Operating Limits	Cooling	Heating
<b>Air Limits</b>		
Min. ambient air, DB	10°F [-12°C] <sup>1</sup>	10°F [-12°C] <sup>1</sup>
Max. ambient air, DB	130°F [54.4°C]	130°F [54.4°C]
<b>Water Limits</b>		
Min. entering water	20°F [-6.7°C] <sup>2</sup>	20°F [-6.7°C]
Max. entering water	120°F [49°C]	90°F [32°C]
Water Flow Range	1.5 to 3.0 gpm/ton [1.6 to 3.2 l/m per kW] <sup>3</sup>	

Notes:

1. To prevent unit damage, the water loop should contain antifreeze to prevent freezing when not in operation.
2. With unit flow-control automation.
3. Unless specified different on performance table for any model size

**Table 8: Commissioning Conditions**

Commissioning Conditions	Cooling	Heating
<b>Air Limits</b>		
Min. ambient air, DB	10°F [-12°C] <sup>1</sup>	10°F [-12°C] <sup>1</sup>
Max. ambient air, DB	130°F [54.4°C]	130°F [54.4°C]
<b>Water Limits</b>		
Min. entering water	20°F [-6.7°C] <sup>2</sup>	20°F [-6.7°C]
Max. entering water	120°F [49°C]	90°F [32°C]
Water Flow Range	1.5 to 3.0 gpm/ton [1.6 to 3.2 l/m per kW] <sup>3</sup>	

Notes:

1. To prevent unit damage, the water loop should contain antifreeze to prevent freezing when not in operation.
2. With unit flow-control automation.
3. Unless specified different on performance table for any model size

### Unit Maximum Water Working Pressure and Flow

Unit Maximum Water Working Pressure PSIG (kPa)	
Unit	145 (100)
Maximum Water Flow Through Unit GPM (l/min)	
036	25 (94.6)
060, 120	35 (132.5)

# Operating Pressures

**Table 9: MW Series Typical Unit Operating Pressures and Temperatures**

MW036-120 (MW120 Per Circuit)								
Source EWT F	Source Water Flow GPM/ton	Cooling						
		Load EWT F @ 1.5-3.0 GPM/Ton	Suction Pressure PSIG	Discharge Pressure PSIG	Super-heat	Sub-cooling	Water Temp Rise F Source	Water Temp Drop F Load
50	1.5	50	80-100	180-200	14-18	18-28	15-30	7-15
		60	90-110	190-210	14-18	18-28		8-17
		70	100-120	200-220	17-21	18-28		8-19
		80	120-140	210-230	18-22	18-28		9-20
	2.25	50	80-100	170-190	15-19	14-22	10-20	7-15
		60	90-110	175-195	15-19	14-22		8-17
		70	100-120	180-200	16-20	14-22		9-19
		80	120-140	200-220	17-21	14-22		9-20
	3.0	50	75-95	165-185	15-19	12-20	5-15	8-16
		60	90-110	170-190	15-19	12-20		8-17
		70	95-115	175-195	16-20	12-20		9-19
		80	120-140	190-210	20-24	12-20		9-20
80	1.5	50	90-110	300-320	11-15	18-25	15-30	7-14
		60	100-120	310-330	11-15	18-25		7-16
		70	110-130	330-350	11-15	18-25		8-18
		80	130-150	350-370	12-16	18-25		9-20
	2.25	50	95-115	295-315	10-14	14-21	12-18	7-14
		60	105-125	305-325	10-14	14-21		8-16
		70	115-135	320-340	11-15	14-21		8-18
		80	130-150	340-360	14-18	14-21		9-20
	3.0	50	100-120	285-305	10-14	12-18	10-15	7-15
		60	110-130	300-320	10-14	12-18		8-16
		70	120-140	310-330	12-16	12-18		9-18
		80	140-160	330-350	13-17	12-18		9-20
110	1.5	50	95-115	475-495	9-13	17-23	14-25	5-11
		60	110-130	490-510	9-13	17-23		6-13
		70	120-140	510-530	10-14	17-23		7-15
	2.25	50	90-110	460-480	9-13	15-20	14-17	5-11
		60	115-135	465-485	9-13	15-20		6-13
		70	120-140	475-495	10-14	15-20		7-15
	3.0	50	90-110	440-460	9-13	12-17	7-13	5-12
		60	110-130	450-470	9-13	12-17		6-14
		70	120-140	470-490	10-14	12-17		7-15
		80	140-160	480-500	11-15	12-17		8-17

• Subcooling is based upon head pressure at compressor service port

Models:  
MW  
036-120

## Operating Pressures

MW036-120 (MW120 Per Circuit)								
Source EWT F	Source Water Flow GPM/ton	Heating						
		Load EWT F @ 1.5-3.0 GPM/Ton	Suction Pressure PSIG	Discharge Pressure PSIG	Super-heat	Sub-cooling	Water Temp Drop F Source	Water Temp Rise F Load
20	3.0	60	50-60	180-200	10-14	6-15	2-6	5-14
		80	50-60	280-300	10-14	6-15		5-14
		90	55-65	290-310	11-15	6-15		4-14
		100	55-65	360-385	11-15	6-15		4-14
		120	55-65	425-435	13-16	6-15		4-13
50	1.5	60	70-80	200-220	11-15	12-18	9-16	6-17
		80	75-85	310-330	11-15	12-18		6-17
		90	80-90	320-340	11-15	12-18		6-17
		100	85-95	380-400	11-15	12-18		5-17
		120	90-100	450-470	11-15	12-18		4-16
	2.25	60	75-85	195-215	10-14	10-14	6-13	7-18
		80	80-90	305-325	10-14	10-14		6-18
		90	85-95	310-330	10-14	10-14		6-18
		100	90-100	360-380	10-14	10-14		6-17
		120	95-105	445-465	10-14	10-14		5-17
	3.0	60	80-90	190-210	9-13	7-15	5-10	7-19
		80	85-95	300-320	9-13	7-15		7-19
		90	90-100	305-325	9-13	7-15		6-19
		100	95-105	360-380	9-13	7-15		6-18
		120	100-110	440-460	9-13	7-15		5-17
80	1.5	60	110-120	220-240	13-17	16-20	15-21	8-18
		80	120-130	310-330	13-17	16-20		8-19
		90	125-135	320-340	13-17	16-20		7-19
		100	130-140	400-420	13-17	16-20		7-19
		120	135-145	480-500	13-17	16-20		6-20
	2.25	60	100-110	215-235	12-16	14-19	9-16	8-20
		80	120-130	290-300	12-16	14-19		8-20
		90	130-140	330-350	12-16	14-19		8-20
		100	140-150	400-420	12-16	14-19		7-20
		120	150-160	475-495	12-16	14-19		6-20
	3.0	60	110-120	220-240	11-15	6-18	7-12	9-21
		80	135-150	280-300	11-15	6-18		8-21
		90	130-140	340-360	11-15	6-18		8-21
		100	140-150	405-425	11-15	6-18		8-21
		120	150-160	490-510	11-15	6-18		6-21

• Subcooling is based upon head pressure at compressor service port

## Preventative Maintenance

### HEAT EXCHANGER MAINTENANCE (DIRECT GROUND WATER APPLICATIONS ONLY)

If the installation is performed in an area with a known high mineral content (125 ppm or greater) in the water, establish a periodic maintenance schedule with the owner so the intermediate heat exchanger is checked regularly. Consult the *Ground-Water Heat Pump* section of this manual for a more detailed water coil material selection. If periodic coil cleaning is necessary, use standard coil cleaning procedures which are compatible with either the heat exchanger material or copper water lines. Generally, the more water flowing through the unit the less chance for scaling therefore 2.5 GPM per ton (2.0 l/m per kW) is recommended as a minimum flow.

### HEAT EXCHANGER MAINTENANCE (ALL OTHER WATER LOOP APPLICATIONS)

Generally water coil maintenance is not needed however, if the installation is located in a system with a known high dirt or debris content, it is best to establish with the owner a periodic maintenance schedule so the coil can be checked regularly. These dirty installations are a result of the deterioration of iron or galvanized piping or components in the system or open cooling towers requiring heavy chemical treatment and mineral buildup through water use. Should periodic coil cleaning be necessary, use standard coil cleaning procedures which are compatible with both the heat exchanger material and copper water lines. Generally, the more water flowing through the unit, the less chance for scaling, however flow rates over 3 GPM per ton (3.9 l/m per kW) can produce water (or debris) velocities that can erode the heat exchanger wall and ultimately produce leaks.

Clean or replace 20 mesh (841 micron) [0.84mm] strainer/filters on a timely schedule.

### COMPRESSORS

Conduct annual amperage checks to ensure amp draw is no more than 10% greater than that indicated by serial plate data.

### CABINET

Do not allow water to stay in contact with the cabinet for long periods of time to prevent corrosion of the cabinet sheet metal. Generally smaller cabinets are set up from the floor a few inches for prevention. The cabinet can be cleaned using a mild detergent.

### REFRIGERANT SYSTEM

To maintain sealed circuit integrity, do not install service gauges unless unit operation appears abnormal. Reference the operating chart for pressure and temperatures. Verify that air and water flow rates are at proper levels before servicing the refrigerant circuit.

If the refrigerant circuit is opened for any reason, a new liquid line filter-drier must be installed.

Models:  
MW  
036-120

# Startup Log Sheet

**Installer:** Complete *Unit and System Checkout* and follow *Unit Startup Procedures* in the IOM. Use this form to record unit information, temperatures, and pressures during startup. Keep this form for reference.

**Job Name:** \_\_\_\_\_

**Street Address:** \_\_\_\_\_

**Model Number:** \_\_\_\_\_

**Serial Number:** \_\_\_\_\_

**Unit Location in Building:** \_\_\_\_\_

**Date:** \_\_\_\_\_

**Sales Order Number:** \_\_\_\_\_

In order to minimize troubleshooting and costly system failures, complete the following checks and data entries before the system is put into full operation.

Temperatures (check one):  °F  °C Antifreeze: \_\_\_\_\_ %

Pressures (check one):  PSIG  kPa Type: \_\_\_\_\_

	Cooling Mode		Heating Mode	
<b>Source</b>				
Entering Fluid Temperature				
Leaving Fluid Temperature				
Temperature Differential		DB		DB
Pressure	In	Out	In	Out
Pressure Differential				
<b>Load</b>				
Entering Fluid Temperature				
Leaving Fluid Temperature				
Temperature Differential		DB		DB
Pressure In	In	Out	In	Out
Pressure Differential				
<b>Compressor</b>				
Amps				
Volts				
Discharge Line Temperature				

**NOTES:**

1. Allow unit to run 15 minutes in each mode before taking data.
2. Never connect refrigerant gauges during startup procedures.
3. Conduct water-side analysis using P/T ports to determine water flow and temperature difference.
4. If water-side analysis shows poor performance, refrigerant troubleshooting may be required.
5. Connect refrigerant gauges as a last resort.

Models:  
MW  
036-120

# Refrigeration Troubleshooting Form

**Customer:** \_\_\_\_\_ **Loop Type:** \_\_\_\_\_ **Startup Date:** \_\_\_\_\_

**Model #:** \_\_\_\_\_ **Serial #:** \_\_\_\_\_ **Antifreeze Type:** \_\_\_\_\_ **%**

**Complaint:** \_\_\_\_\_

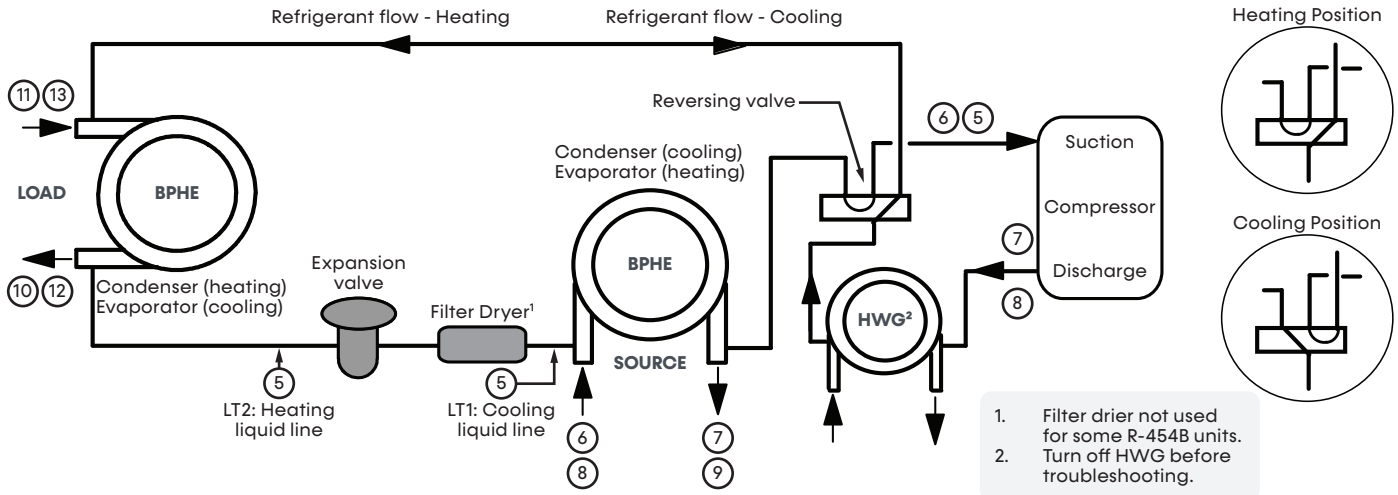

Description		Heating	Cooling	Notes
<b>Water Side Analysis</b>				
1	Water In Temp.			
2	Water Out Temp.			ΔT =
3	Water In Pressure			
4	Water Out Pressure			
4a	Pressure Drop			
4b	GPM			

Heat of Extraction (Absorption) or Heat of Rejection:

HE (Btuh) = \_\_\_\_\_ or HR (Btuh) = \_\_\_\_\_  
 \_\_\_\_\_ Flow Rate (GPM) x \_\_\_\_\_ ΔT (°F) x \_\_\_\_\_ Fluid Factor

**Fluid Factor:**  
**500 (Water) 485 (Antifreeze)**

<b>Refrigerant Analysis</b>				
5	Suction Temp.			
6	Suction Pressure			
6a	Saturation Temp.			
6b	Superheat			
7	Discharge Temp.			
8	Discharge Pressure			
8a	Saturation Temp.			
8b	Subcooling			
9	Liquid Line Temp			
10	Load Water In Temp.			
11	Load Water Out Temp.			ΔT =
12	Load Water In Pressure			
13	Load Water Out Pressure			
13a	Pressure Drop			
13b	Flow Rate GPM [l/s]			

Models:  
MW  
036-120

# Warranty



## LIMITED EXPRESS WARRANTY - MWM/Commercial-SERIES WATER-SOURCE HEAT PUMP

**Congratulations on purchasing your new HVAC equipment. It has been designed for long life and reliable service, and is backed by one of the strongest warranties in the industry. Your unit automatically qualifies for the warranty coverage listed below, provided you keep your proof of purchase (receipt) for the equipment and meet the warranty conditions.**

### GENERAL

This limited express warranty is applicable to MWM/comm-Series water-source heat pumps manufactured by Comfort-Aire/Century, and used in commercial installations.

### LIMITED ONE (1) YEAR PARTS EXPRESS WARRANTY

Comfort-Aire/Century warrants all parts of the MWM/comm-Series water-source heat pump used in commercial applications to be free from defects in workmanship and materials for normal use and maintenance for one (1) year from the date of purchase by the original consumer for the original installation. This Express Limited Warranty applies only when the system is installed per Comfort-Aire/Century installation instructions and in accordance with all local, state and national codes for normal use.

### LIMITED FIVE (5) YEAR EXPRESS WARRANTY ON COMPRESSOR

We will replace a compressor which proves to be defective for a period of five (5) years from date of heat pump purchase. All restrictions, limitations and procedures for the one year parts warranty apply to the additional compressor warranty period.

### EXCEPTIONS

The Limited Express Warranty does not cover normal maintenance—Comfort-Aire/Century recommends that regular inspection/maintenance be performed at least once a season and proof of maintenance be kept. Additionally, labor charges, transportation charges for replacement parts, replacement of refrigerant or filters, any other service calls/repairs are not covered by this Limited Warranty. It also does not cover any portion or component of the system that is not supplied by Comfort-Aire/Century, regardless of the cause of failure of such portion or component.

### CONDITIONS FOR WARRANTY COVERAGE

- Unit must be operated according to Comfort-Aire/Century operating instructions included with the unit and cannot have been subjected to accident, alteration, improper repair, neglect or misuse, or an act of God (such as flood)
- Serial numbers and/or rating plate have not been altered or removed
- Installation was done by a trained, licensed or otherwise qualified geothermal dealer/contractor
- Performance cannot be impaired by use of any product not authorized by Comfort-Aire/Century, or by any adjustments or adaptations to components
- Damage has not been a result of inadequate wiring or voltage conditions, use during brown-out conditions, or circuit interruptions
- Air flow around any section of the unit has not been restricted
- Unit remains in the original installation
- Unit was not purchased over the internet

### DURATION OF WARRANTY & REGISTRATION

The warranty begins on the date of purchase by the original consumer. The consumer must register their product at [www.heatcontroller.com](http://www.heatcontroller.com) within 90 days of purchase. The consumer must retain a receipted bill of sale as proof of warranty period. Without this proof, the express warranty begins on the date of shipment from the factory.

### REMEDY PROVIDED BY THE LIMITED EXPRESS WARRANTY

The sole remedy under the Limited Warranty is replacement of the defective part. If replacement parts are required within the period of this warranty, Comfort-Aire/Century replacement parts shall be used; any warranty on the replacement part(s) shall not affect the applicable original unit warranty. Ready access to the unit for service is the owner's responsibility. Labor to diagnose and replace the defective part is not covered by this Limited Express Warranty. If for any reason the replacement part/product is no longer available during the warranty period, Comfort-Aire/Century shall have the right to allow a credit in the amount of the current suggested retail price of the part/product instead of providing repair or replacement.

### LIMITATION OF LIABILITY

1. There are no other express or implied warranties. Comfort-Aire/Century makes no warranty of merchantability. We do not warrant that the unit is suitable for any particular purpose or can be used in buildings or rooms of any particular size or condition except as specifically provided in this document. There are no other warranties, express or implied, which extend beyond the description in this document.
2. All warranties implied by law are limited in duration to the one-term of the parts warranty. Your exclusive remedy is limited to the replacement of defective parts. **We will not be liable for any consequential or incidental damages caused by any defect in this unit.**
3. This warranty gives you specific legal rights and you may also have other rights which vary from state to state. Some states do not allow limitation on how long an implied warranty lasts or do not allow the exclusion or limitation of incidental or consequential damages, so the above limitations or exclusions may not apply to you.
4. No warranties are made for units sold outside the continental United States and Canada. Your distributor or final seller may provide a warranty on units sold outside these areas.
5. Comfort-Aire/Century will not be liable for damages if our performance regarding warranty resolution is delayed by events beyond our control including accident, alteration, abuse, war, government restrictions, strikes, fire, flood, or other acts of God.

**Please follow the below steps to register your product.**

- **Please log onto our website [www.heatcontroller.com](http://www.heatcontroller.com)**
- **Resources**
- **Product Registration**
- **Complete the requested information in all caps, especially the Email Address**
- **Press the "Continue" button at the bottom**
- **A copy of the registration will be sent to the email address that you entered at the top of the page for your records**

### KEEP THIS INFORMATION AS A RECORD OF YOUR PURCHASE

Apply Serial Number and Model Number sticker here (from product carton). If unavailable, write serial number and model number below (can be found on unit rating plate).

Date of Purchase \_\_\_\_\_ Date Installation Completed \_\_\_\_\_  
 Component of new HVAC system     Replacement heat pump only  
 Remember to retain your bill of sale as proof of warranty period and ownership.



**Please visit [www.heatcontroller.com](http://www.heatcontroller.com) to register your new product**

**Notes**

Models:  
MW  
036-120

Models:  
MW  
036-120

## Notes

---

**Notes**

Models:  
MW  
036-120

Models:  
MW  
036-120

## Revision History

Date	Section	Description
03/27/26	All	Updated DXM2.5 to DXM2.6 throughout
10/16/25	General Information	Updated <i>Prepare Units for Installation as Follows</i>
	Dimensional Data	Updated graphic
	Hot Water Generator	Updated graphics
	Electrical Data	Updated all electrical data
	Electrical: Low-Voltage Wiring	Updated <i>Variable Water Flow Freeze Protection</i>
	Electrical: DXM2.6 and Wireless Service Tool	Updated section title and added the Wireless Service Tool AOM QR code
	Unit and System Checkout	Updated section
	Unit Startup Procedure	Updated the <b>Operating Limits</b> and <b>Commissioning Conditions</b> tables
All		Removed CXM2 from the document
		Updated organization and labeling
06/26/25	All	Created



1900 Wellworth Ave. | Jackson, MI 49203  
Phone: 517-787-2100  
www.heatcontroller.com

Due to ongoing product improvements, specifications and dimensions are subject to change and correction without notice or incurring obligations. Determining the application and suitability for use of any product is the responsibility of the installer. Additionally, the installer is responsible for verifying dimensional data on the actual product prior to beginning any installation preparations.

Incentive and rebate programs have precise requirements as to product performance and certification. All products meet applicable regulations in effect on date of manufacture; however, certifications are not necessarily granted for the life of a product. Therefore, it is the responsibility of the applicant to determine whether a specific model qualifies for these incentive/rebate programs.

Engineered and assembled in the USA.

© Heat Controller, Inc. All Rights Reserved 2025