

Submittal Data

B-VFH12FA-1

Project Name:	
Location:	
Engineer:	
Submitted to:	
Submitted by:	
Reference:	

Approval:	
Date:	
Construction:	
Unit #:	
Drawing #:	

INDOOR UNIT DATA

Power Supply	Ph-V-Hz	1Ph,208/230V,60Hz
Cooling Capacity	Btu/h	12000
HeatingCapacity	Btu/h	13000

Indoor Fan Motor

Model		FN30A-ZL
Input	W	45
RLA	A	0.15

Air Flow & Noise Level

Indoor air flow (H/M/L)	CFM	588/441/324
Indoor noise level (H/M/L)	Db(A)	52/48/44

Physical Data

Dimensions (W*D*H*)	inch	27.56x8.46x23.62
Packing (W*D*H*)	inch	31.14x11.3x27.95
Net/Gross weight	lbs.	33.1/39.7

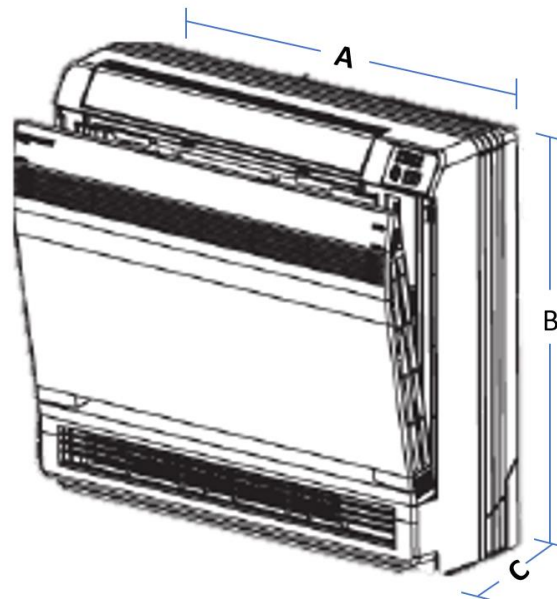

<u>Accessories</u>		<u>Dimensions</u>		
84711	3 Pole mini-split disconnect switch	A	27.56"	Width
		B	23.62"	Height
		C	8.46"	Depth