

# Submittal Data

## B-VFH18FA-1

Project Name:	
Location:	
Engineer:	
Submitted to:	
Submitted by:	
Reference:	

Approval:	
Date:	
Construction:	
Unit #:	
Drawing #:	

### INDOOR UNIT DATA

Power Supply	Ph-V-Hz	1Ph,208/230V,60Hz
Cooling Capacity	Btu/h	17000
HeatingCapacity	Btu/h	18700
Indoor Fan Motor		
Model		FN30A-ZL
Input	W	45
RLA	A	0.15

### Air Flow & Noise Level

Indoor air flow	CFM	494/470./423/382/341/311/241
Indoor noise level (H/M/L)	Db(A)	58/56/54/51/47/45/43

### Physical Data

Dimensions (W*D*H*)	inch	27.6x8.5x23.6
Packing (W*D*H*)	inch	31.1x11.3x28
Net/Gross weight	lbs.	33.1/39.7

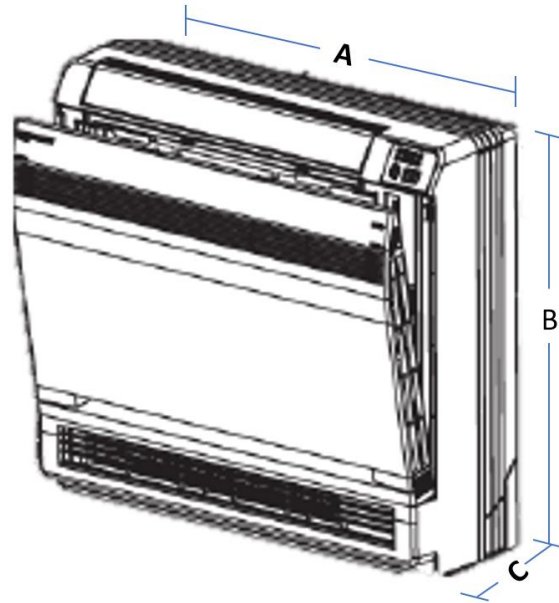

### Dimensions

<u>Accessories</u>		<u>Dimensions</u>	
84711	3 Pole mini-split disconnect switch	A	27.56" Width
		B	23.62" Height
		C	8.46" Depth