

---

*Comfort-Cire*®

**Century**®

---

## **OWNER'S MANUAL**

# **Super-Slim Four-Way Cassette**

### **Models**

B-VMH09CU-1

B-VMH12CU-1

B-VMH18CU-1

## CONTENTS

IMPORTANT SAFETY INFORMATION.....	2
HINTS FOR ECONOMICAL OPERATION.....	3
PART NAMES.....	3
MANUAL OPERATION.....	10
ADJUSTING AIR FLOW DIRECTION.....	11
MAINTENANCE.....	12
AIR CONDITIONER OPERATIONS AND PERFORMANCE.....	14
INSTALLATION.....	15
TROUBLESHOOTING.....	16
TROUBLESHOOTING (CONCERNING REMOTE CONTROLLER).....	16
WARRANTY.....	19

### IMPORTANT SAFETY INFORMATION

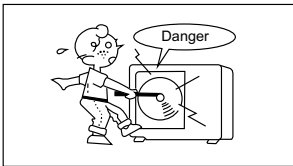

**⚠ CAUTION**

Do not attempt to install this unit by yourself. This unit requires installation by qualified persons.

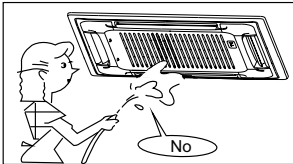

**⚠ DANGER**

Do not attempt to service the unit yourself. This unit has no user serviceable components. Opening or removing the cover will expose you to dangerous voltage. Turning off the power supply will not prevent potential electric shock.

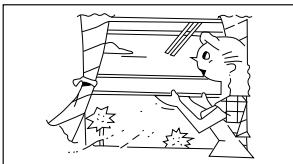

**⚠ DANGER**

Never put hands or objects into the Air Outlet of indoor or outdoor units. These units are installed with a fan running at high speed. To touch the moving fan will cause serious injury.

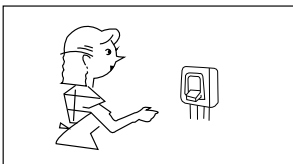

**⚠ DANGER**

To avoid the risk of serious electrical shock, Never sprinkle or spill water or liquids on unit.

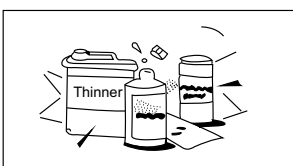

**⚠ WARNING**

Ventilate the room regularly while the air conditioner is in use, especially if there is also a gas appliance in use in this room, Failure to follow these directions may result in a loss of oxygen in the room.

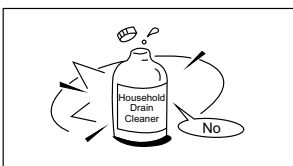

**⚠ WARNING**

To prevent electric shock, turn off the power or disconnect the power supply plug before beginning any cleaning or other routine maintenance. Follow the directions for cleaning in the Owner's Manual.

**⚠ WARNING**

Do not use liquid cleaners or aerosol cleaners, use a soft and dry cloth for cleaning the unit. To avoid electric shock, never attempt to clean the units by sprinkling water.

**⚠ CAUTION**

Do not use caustic household drain cleaners in the unit. Drain cleaners can quickly destroy the unit components (drain pan and heat exchanger coil etc).

**⚠ NOTE**

For proper performance, operate the unit in temperature and humidity ranges indicated in this owner's manual. If the unit is operated beyond these conditions, it may cause malfunctions of the unit or dew dripping from the unit.

## HINTS FOR ECONOMICAL OPERATION

The following should be noticed to ensure an economical operation. (Refer to corresponding chapter for details)

- Adjust the air flow direction properly to avoid winding toward your body.
- Adjust the room temperature properly to get a comfortable environment and to avoid supercooling and superheat.
- In cooling, close the curtains to avoid direct sunlight.
- To keep cool or warm air in the room, never open doors or windows more often than necessary.
- Set the timer for the desired operating time.
- Never put obstructions near the air outlet or the air inlet. Or it will cause lower efficiency, even a sudden stop.
- If you don't plan to use the unit for a long time, please disconnect power and remove the batteries from the remote controller. When the power switch is connected, some energy will be consumed, even if the air conditioner isn't in operation. So please disconnect the power to save energy. And please switch the power on 12 hours before you restart the unit to ensure a smooth operation.
- A clogged air filter will reduce cooling or heating efficiency, please clean it once two weeks.

## PART NAMES

The air conditioner consists of the indoor unit, the outdoor unit, the connecting pipe and the remote controller.

### ■ Cassette Type

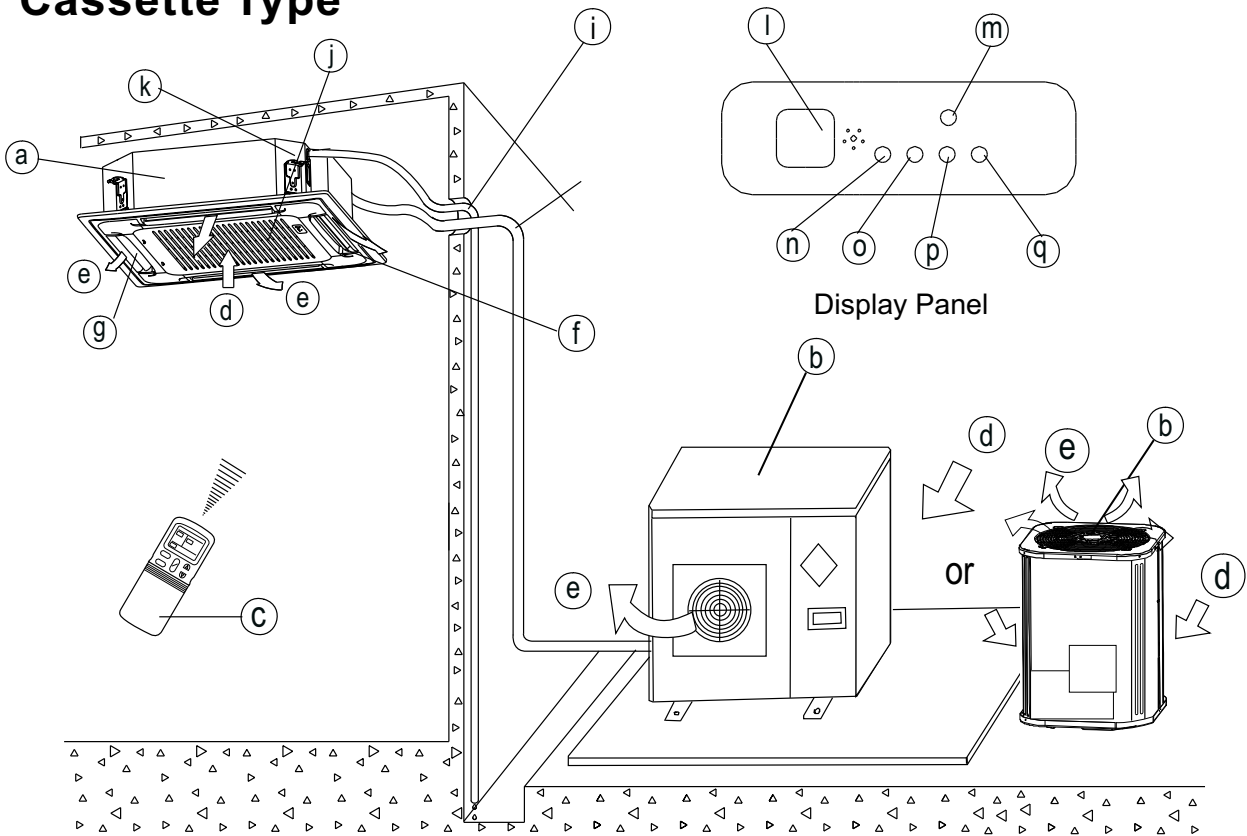

### NOTICE!

This chart is based on 24000Btu/h type. So, a few differences may exist on the outlook and functions from yours.

## ■ Duct and Ceiling Type

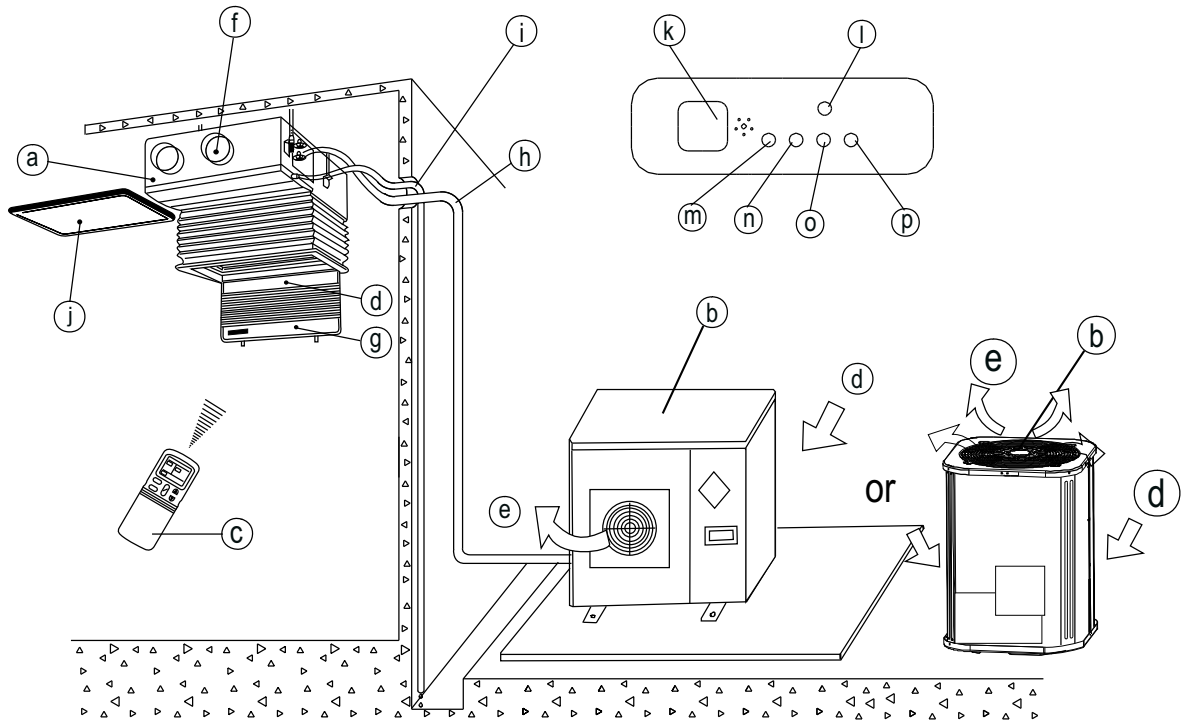

### NOTICE!

This chart is based on 24000Btu/h type. So, a few differences may exist on the outlook and functions from yours.

### NAMES AND FUNCTIONS

- |                                    |                                      |
|------------------------------------|--------------------------------------|
| a) indoor unit                     | b) outdoor unit                      |
| c) remote controller               | d) air-in                            |
| e) air-out                         | f) air outlet                        |
| g) air flow louver (at air outlet) | h) connecting pipe                   |
| i) drain hose                      | j) air inlet (with air filter in it) |
| k) infrared signal receiver        | l) manual button                     |
| m) operation lamp                  | n) timer indicator                   |
| o) PRE-DEF indicator               | p) alarm indicator                   |
- (NOTICE: In the case of "cooling only type", it is the "FAN ONLY" indicator.)

### NOTE:

All the pictures in this manual are for explanation purpose only. There may be slightly different from the air conditioner you purchased (depend on model). The actual shape shall prevail.

## ■ For Slim DUCT with air inlet box Type

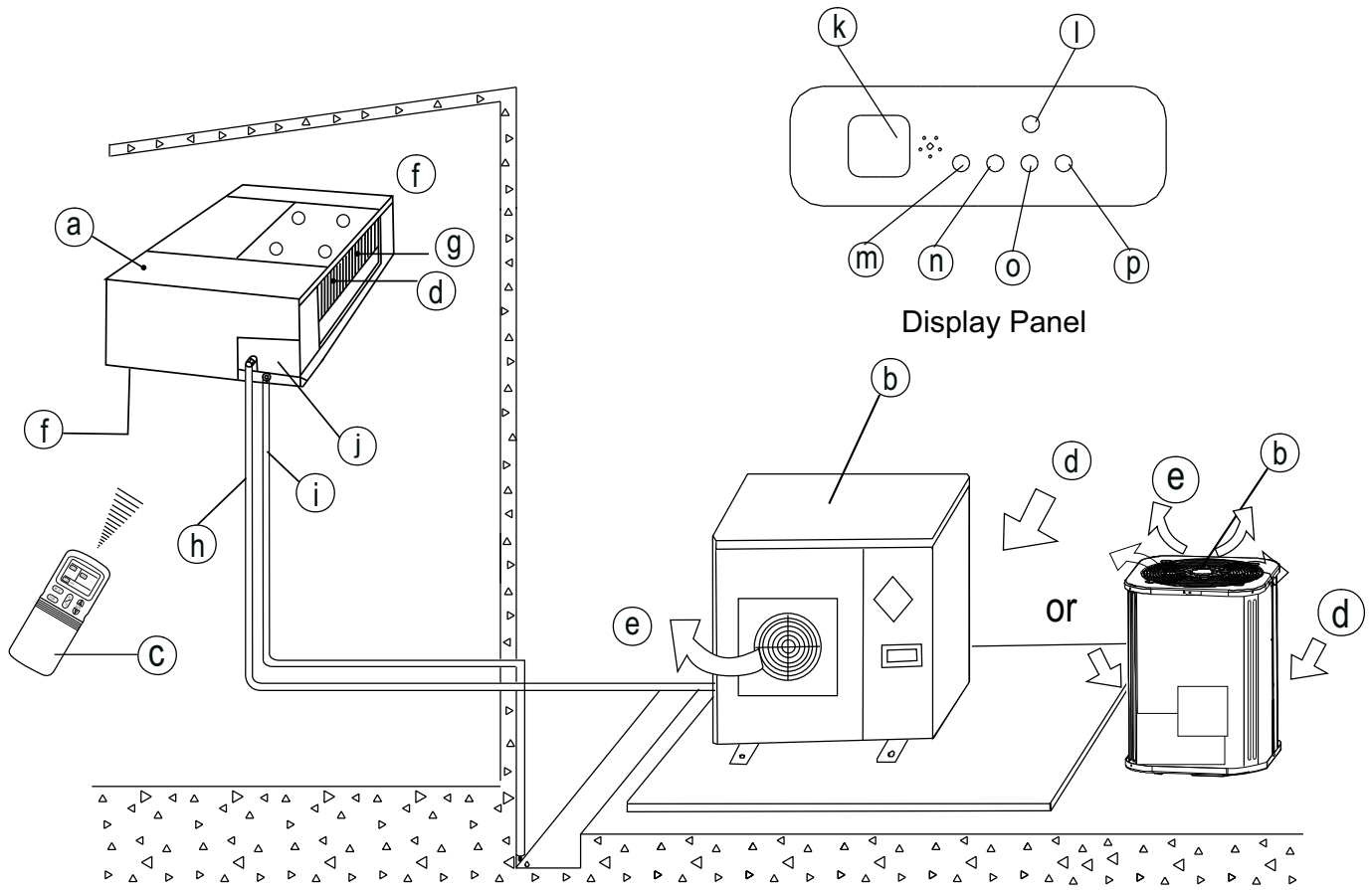

### NAMES AND FUNCTIONS

(a)	indoor unit	(b)	outdoor unit	(c)	remote Controller
(d)	air-outlet	(e)	air-out	(f)	air- inlet
(g)	heat exchanger	(h)	connecting pipe	(i)	drain hose
(j)	E-Box				
(k)	infrared signal receiver	(l)	temporary button		
(m)	operation lamp	(o)	PRE./DEF.Indicator (Cooling and heating type) or fan only indicator (cooling only type)		
(n)	timer indicator	(p)	alarm indicator		

## ■ Four-way Cassette (slim) Type

Control board

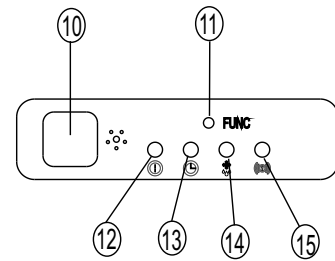

Indoor Unit Assy

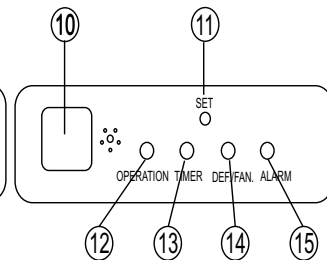
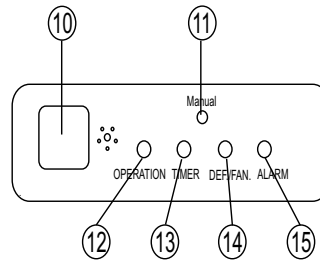
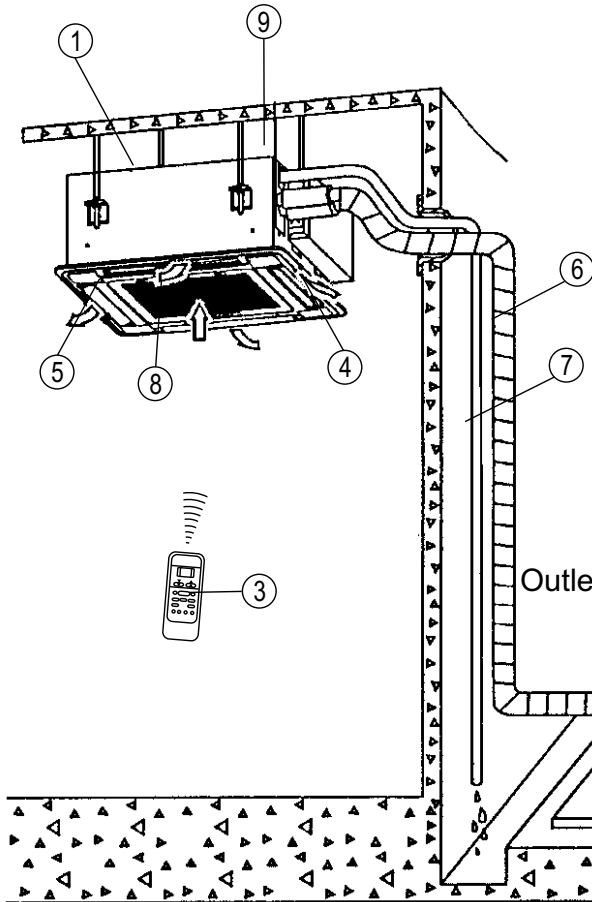

**NOTE:**

These three indication lamps flash in cycles when solar PV ECO function is activated. (Applicable to the unit adopts solar photovoltaic system only.)

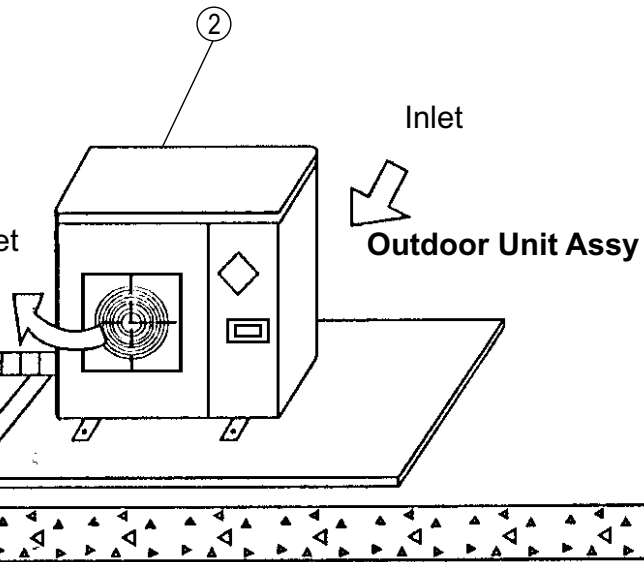

This picture is based on the type of 18000Btu/h, So the appearance and function may be slightly different from the unit you purchased.

**Parts Names:**

① Indoor Unit	② Outdoor Unit	③ Remote Controller
④ Air outlet	⑤ Vertical louver	⑥ Connecting pipe
⑦ Drain hose	⑧ Air Inlet (Air filter installed inside to prevent the dust)	
⑨ Drain Pump (Internal installed), water drain from indoor unit.		
⑩ Infrared Signal receiver	⑪ Manual button/SET button	⑫ Run lamp
⑬ Timer indicator	⑭ Defrost indicator heating/cooling type or fan indicator (cooling only type)	
⑮ Alarm indicator		

## ■ Ceiling & Floor Type (for VERTICAL DISCHARGE AIR CONDITIONER)

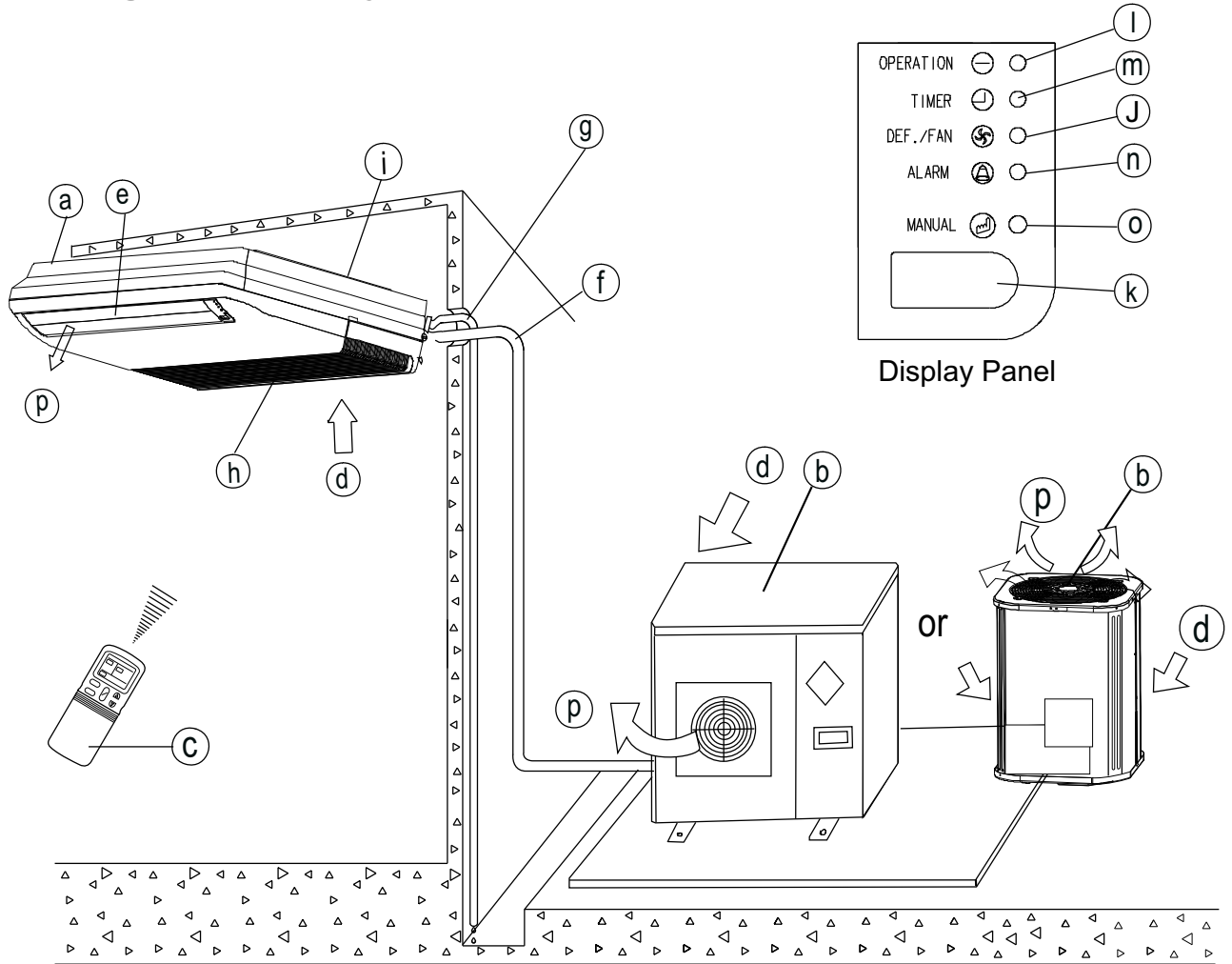

### NOTICE!

The chart based on one model of our product is for reference only, which may be different from the unit you purchased.

### NAMES AND FUNCTIONS

(a)	indoor unit	(b)	outdoor unit	(c)	remote controller
(d)	air-in	(e)	air flow louver (at air outlet)	(f)	connecting pipe
(g)	drain hose	(h)	air inlet (with air filter in it)		
(i)	installation part	(j)	<b>FAN/DEF indicator</b> (For cooling and heating type, it's DEF., for cooling only type, it's FAN)		
(k)	infrared signal receiver	(l)	operation lamp		
(m)	timer indicator	(n)	alarm indicator		
(o)	temporary button	(p)	air-out		

## ■ Ceiling & Floor Type

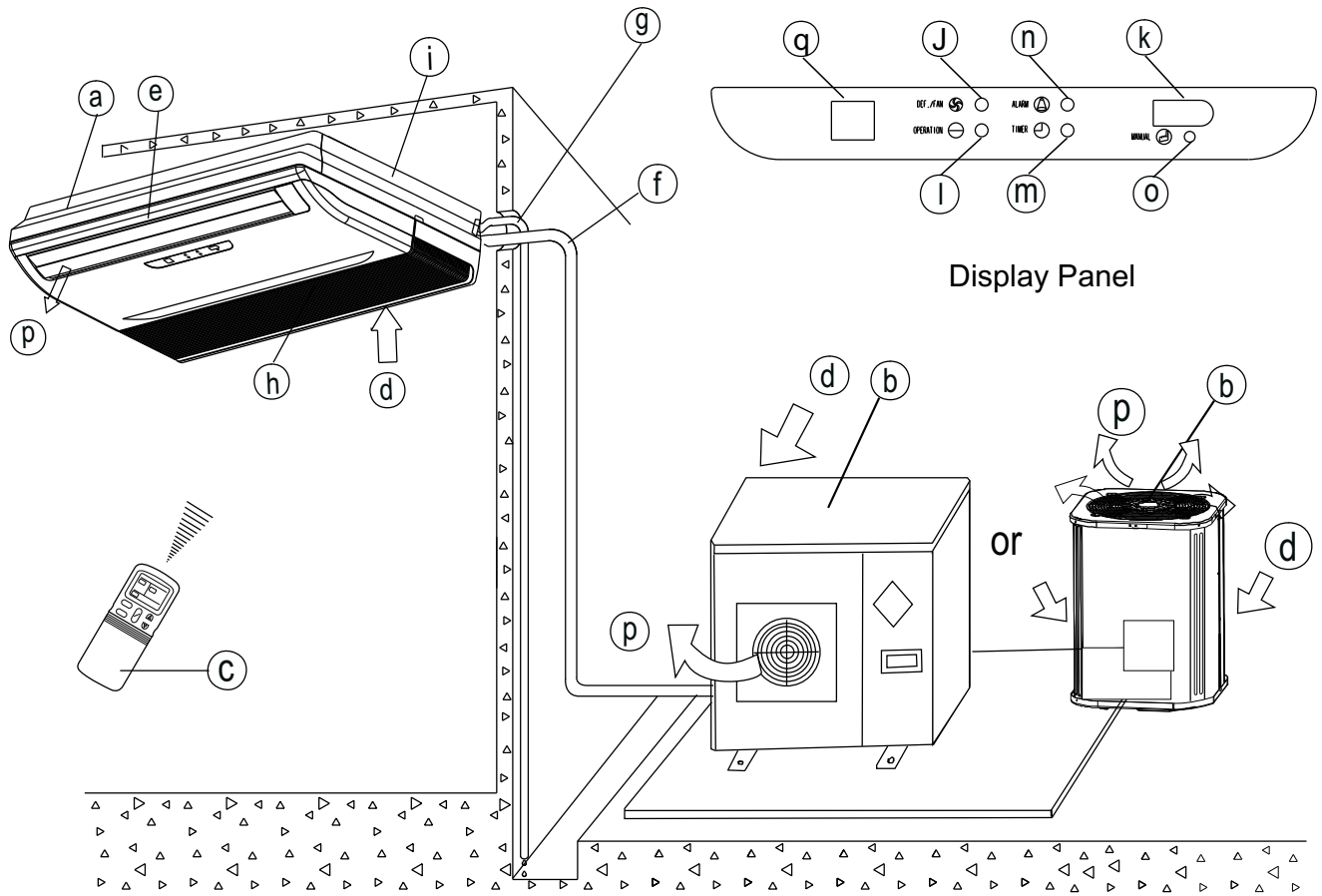

### NOTICE!

The chart based on one model of our product is for reference only, which may be different from the unit you purchased.

### NAMES AND FUNCTIONS

Ⓐ	indoor unit	Ⓑ	outdoor unit	Ⓒ	remote controller
Ⓓ	air-in	Ⓔ	FAN/DEF indicator (For cooling and heating type, it's DEF.,for cooling only type, it's FAN)	Ⓕ	connecting pipe
Ⓖ	drain hose	Ⓕ	operation lamp		
Ⓘ	installation part	Ⓖ	Alarm Indicator		
Ⓚ	infrared signal receiver	Ⓟ	air-out	Ⓠ	Temperature display
Ⓜ	timer indicator				
Ⓞ	temporary button				

## ■ Ceiling & Floor Type

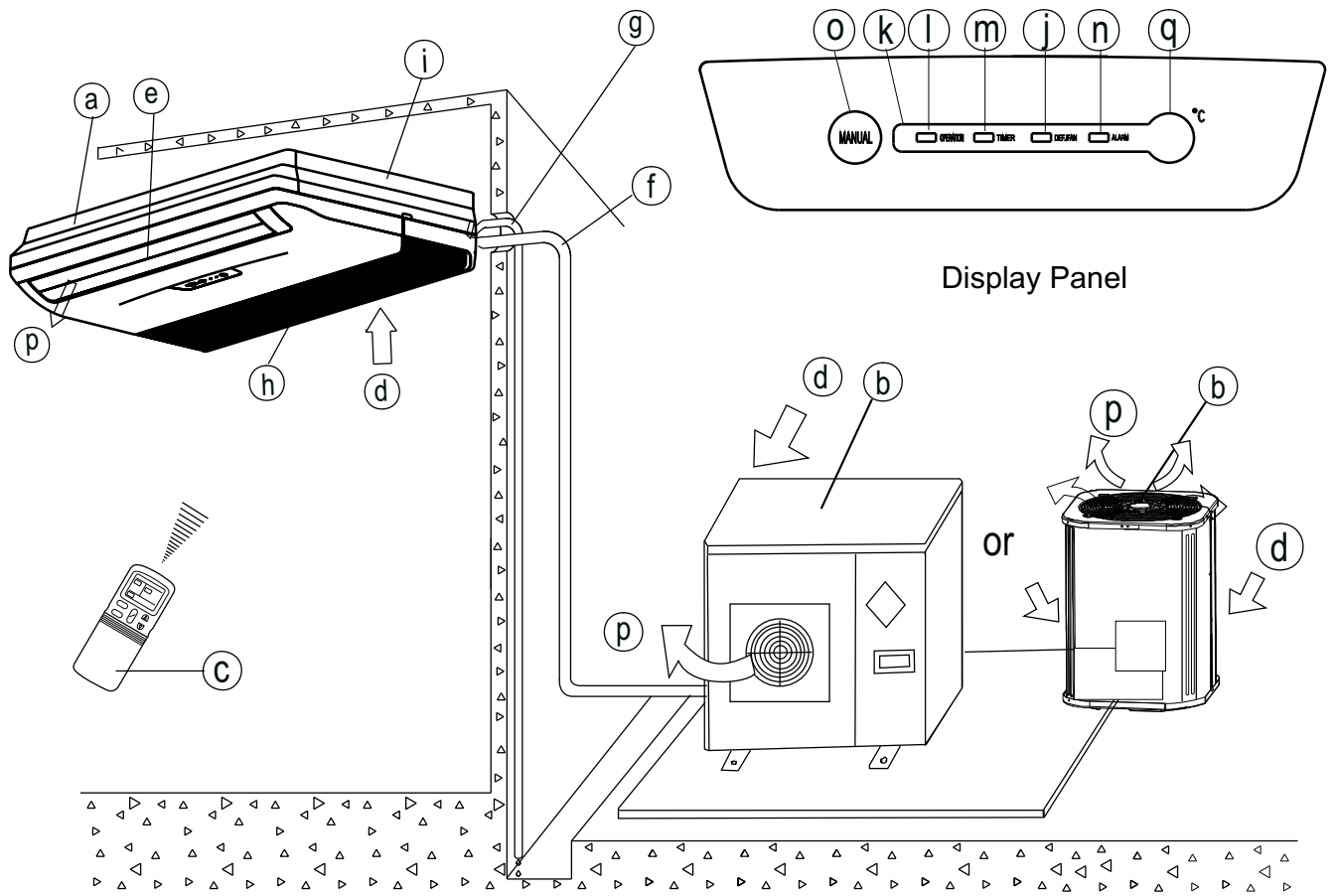

### NOTICE!

The chart based on one model of our product is for reference only, which may be different from the unit you purchased.

### NAMES AND FUNCTIONS

Ⓐ	indoor unit	Ⓑ	outdoor unit	Ⓒ	remote controller
Ⓓ	air-in	Ⓔ	air flow louver (at air outlet)	Ⓕ	connecting pipe
Ⓖ	drain hose	Ⓕ	air inlet (with air filter in it)		
Ⓘ	installation part	Ⓖ	<b>FAN/DEF indicator</b> (For cooling and heating type, it's DEF.,for cooling only type, it's FAN)		
Ⓚ	infrared signal receiver	Ⓛ	operation lamp		
Ⓜ	timer indicator	Ⓝ	AlarmIndicator		
⓪	temporary button	Ⓟ	air-out	Ⓠ	Temperature display

## MANUAL OPERATION

### ■ Ceiling & Floor

This function is used to operate the unit temporarily in case you misplace the remote controller or its batteries are exhausted. Two modes including AUTO and FORCED COOL can be selected through the TEMPORARY BUTTON on the air-in grill control box of the indoor unit. Once you push this button, the air conditioner will run in such order: AUTO, FORCED COOL, OFF, and back to AUTO.

#### 1 AUTO

The OPERATION lamp is lit, and the air conditioner will run under AUTO mode. The remote controller operation is enabled to operate according to the received signal.

#### 2 FORCED COOL

The OPERATION lamp flashes, the air conditioner will turn to AUTO after it is enforced to cool with a wind speed of HIGH for 30 minutes. The remote controller operation is disabled.

#### 3 OFF

The OPERATION lamp goes off. The air conditioner is OFF while the remote controller operation is enabled.

### ■ Four-way Cassette

This function is used to operate the unit temporarily in case you misplace the remote controller or its batteries are exhausted. Two modes including AUTO and mandatory COOL can be selected through the TEMPORARY BUTTON on the air inlet grill control box of the indoor unit. Once you push this button, the air conditioner will run in such order: AUTO, mandatory COOL, OFF, and back to AUTO.

#### 1 AUTO

The OPERATION lamp is lit, and the air conditioner will run under AUTO mode. The remote controller operation is enabled to operate according to the received signal.

#### 2 MANDATORY COOL

The OPERATION lamp flashes, the air conditioner will turn to AUTO after it is enforced to cool with a wind speed of HIGH for 30 minutes. The remote controller operation is disabled.

#### 3 OFF

The OPERATION lamp goes off. The air conditioner is OFF while the remote controller operation is enabled.

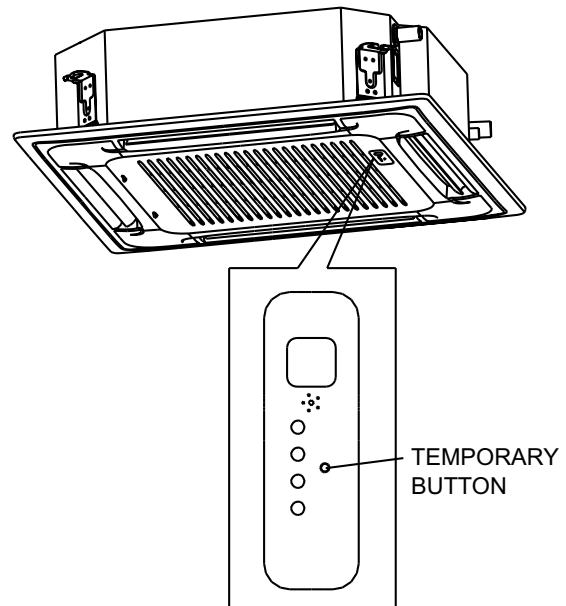

# ADJUSTING AIR FLOW DIRECTION

## ■ Cassette Type

While the unit is in operation, you can adjust the air flow louver to change the flow direction and naturalize the room temperature evenly. Thus you can enjoy it more comfortably.

1. Set the desired air flow direction.

Push the **SWING** button to adjust the louver to the desired position and push this button again to maintain the louver at this position.

2. Adjust the air flow direction automatically.

Push the **SWING** button, the louver will swing automatically.

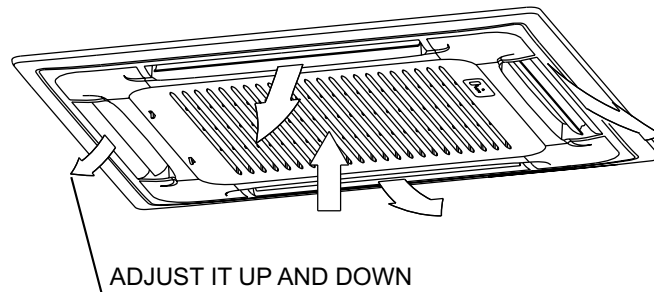

While this function is set, the swing fan of indoor unit runs; otherwise, the swing fan doesn't run. The swing scale of every side is 30°. When the air conditioner isn't in operation (including when "TIMER ON" is set), the **SWING** button will be disabled.

## Duct and Ceiling Type

The following is how to adjust air flow direction when air outlet part (separately saled) is used with the indoor unit.

### Cooling

To effectively cool the whole room, please set the louver so that the air can come out horizontally.

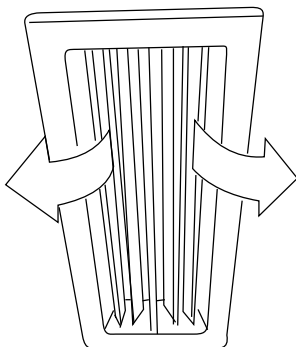

### Heating

To effectively heat the bottom of the room, please set the louver so that the air can come out downwards.

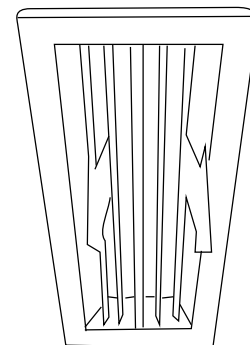

## MAINTENANCE

### ▲WARNING

#### WARNING

Before you clean the air conditioner, be sure to disconnect the power supply plug.

### Cleaning the indoor unit and remote controller

### ▲CAUTIONS

- Use a dry cloth to wipe the indoor unit and remote controller.
- A cloth dampened with cold water may be used on the indoor unit if it is very dirty.
- Never use a damp cloth on the remote controller.
- Do not use a chemically-treated duster for wiping or leave such material on the unit for long, because it may damage or fade the surface of the unit.
- Do not use benzine, thinner, polishing powder, or similar solvents for cleaning. These may cause the plastic surface to crack or deform.

If you do not plan to use the unit for at least 1 month.

- (1) Operate the fan for about half a day to dry the inside of the unit.
- (2) Stop the air conditioner and disconnect power.
- (3) Remove the batteries from the remote controller.

### Checks before operation

### ▲CAUTIONS

- Check that the wiring is not broken off or disconnected.
- Check that the air filter is installed. (Some air-conditioners haven't air filters.)
- Check that the outdoor unit air outlet or inlet is not blocked.

Before you clean the air conditioner, be sure to disconnect the power supply plug.

### Cleaning the air filter

- The air filter can prevent the dust or other particulate from going inside. In case of blockage of the filter, the working efficiency of the air conditioner may greatly decrease. Therefore, the filter must be cleaned every two weeks during long-time usage.
- If the air conditioner is positioned in a dusty place, the cleaning frequency of the air filter must be increased.
- If the accumulated dust is too heavy to be cleaned, please replace the filter with a new one.
- The filter cleaning should be performed by a suitable service provider.

## ■ Cassette Type

### 1. Open the air-in grill

Push the grill switches towards the middle simultaneously as indicated in sketch A. Then pull down the air-in grill.

**Caution:** The control box cables, which are originally connected with the main body electrical terminators must be disconnected.

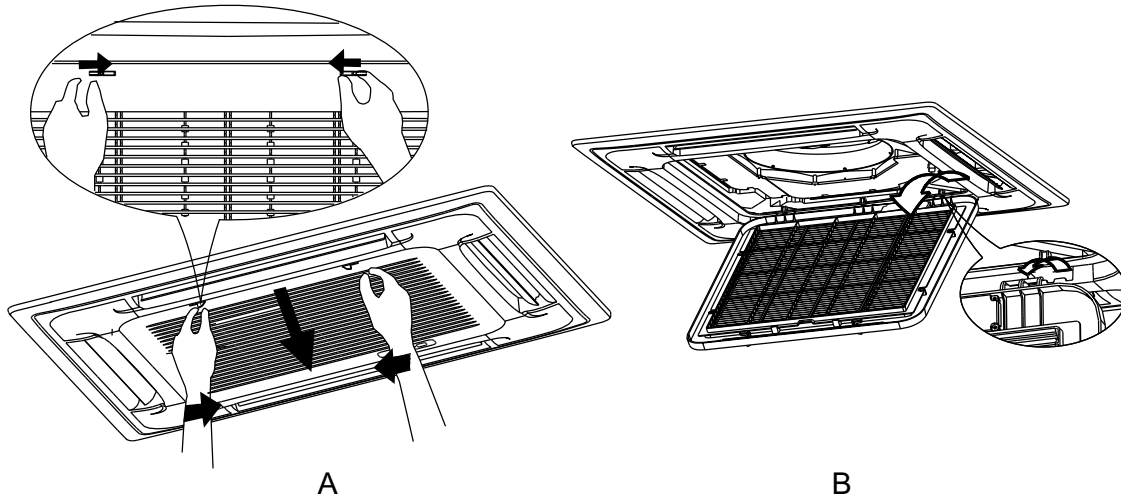

### 2. Take out the air-in grill (together with the air filter shown in Sketch B).

Pull the air-in grill down at 45° and lift it up to take out the grill.

### 3. Dismantle the air filter.

4. Clean the air filter (Vacuum cleaner or pure water may be used to clean the air filter. If the dust accumulation is too heavy, please use soft brush and mild detergent to clean it and dry in cool place).

## ■ Duct and Ceiling Type

### 1. Open the air-in grill

Push the grill switches towards the middle simultaneously as indicated in follow figure sketch. Then pull down the air-in grill.

**Caution:** The control box cables, which are originally connected with the main body electrical terminators must be pulled off before doing as indicated above.

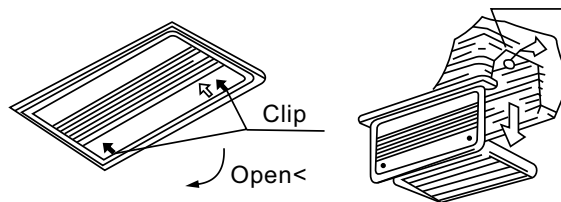

### 2. Take out the air-in grill.

### 3. Dismantle the air filter.

4. Clean the air filter (Vacuum cleaner or pure water may be used to clean the air filter. If the dust accumulation is too heavy , please use soft brush and mild detergent to clean it and dry out in cool place) .

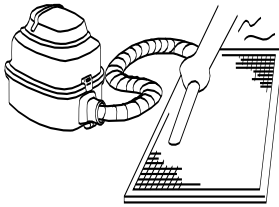

Fig. 1

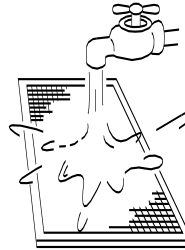

Fig. 2

- The air-in side should be face up when using vacuum cleaner. (See Fig. 1)
- The air-in side should be face down when using water. (See Fig. 2)

**Cautions :** Do not dry the air filter under direct sunshine or with fire.

5. Re-install the air filter

6. Install and close the air-in grill in the reverse order of step 1 and 2 and connect the control box cables to the corresponding terminators of the main body .

## AIR CONDITIONER OPERATIONS AND PERFORMANCE

### Three-minute protection feature

A protection feature prevents the air conditioner from being activated for approximately 3 minutes when it restarts immediately after operation.

### Power failure

Power failure during operation will stop the unit completely.

- The OPERATION lamp on the indoor unit will start flashing when power is restored.
- To restart operation, push the ON/OFF button on the remote controller.
- Lightning or a car wireless telephone operating nearby may cause the unit to malfunction.

Disconnect the unit with the power and then turn the power on again. Push the ON/OFF button on the remote controller to restart operation.

### Air conditioner operating conditions

For proper performance, run the air conditioner under the following temperature conditions:

Mode Temperature	Cooling operation	Heating operation	Drying operation
Room temperature	17°C~32°C (62°F~90°F)	0°C~30°C (32°F~86°F)	17°C~ 32°C/ 62°F~ 90°F

**NOTE:**

1. If air conditioner is used outside of the above conditions, certain safety protection features may come into operation and cause the unit to function abnormally.
2. Room relative humidity less than 80%. If the air conditioner operates in excess of this figure, the surface of the air conditioner may attract condensation. Please set the vertical air flow louver to its maximum angle (vertically to the floor), and set HIGH fan mode.
3. Optimum performance will be achieved within these operating temperatures.

## **Special functions**

### **Refrigerant Leakage Detection(optional):**

With this new technology, the display area will display EC (if applicable) and the LED indication lamps continue flashing when the outdoor unit detects refrigerant leakage.

### **Louver Angle Memory Function(optional):**

For some models, the machine is designed with louver angle memory function. Power failure during operation or pressing the ON/OFF button on the remote controller will stop the unit completely. When the power restores or pressing the ON/OFF button on the remote controller again, the unit restarts automatically with the previous open angle of the horizontal louver by the memory function. So we strongly recommend that the open angle of the horizontal louver should not be set too small, in case the condensed water forms and drops from the horizontal louver. Press the Manual control button and the open angle of the horizontal louver will be restored to the standard angle.

## **INSTALLATION**

### **Location:**

- During cooling operation, the air conditioner will dry the room air, so please fix a pipe to drain all the water away from the air conditioner.
- Please mount the indoor unit more than four feet away from the TV set and the radio in order to avoid picture and noise interference.
- Powerful radio transmitters or any other devices radiating high frequency radio waves can cause the air conditioner to malfunction. Please consult the dealer where you purchased the air conditioner before installing it.
- Do not mount the unit in a dangerous area with combustible gas or volatile chemicals.
- If the air conditioner operates in an atmosphere containing oils (machine oil), salt (near a coastal area), sulfide gas (near a hot spring), etc., such substances may lead to failure of the air conditioner.

### **Be careful of noise or vibrations**

- Please fix the unit in a stable place to avoid the noise or vibrations.
- The noise near the air outlet of the outdoor unit may enter the air exit.
- Locate the outdoor unit where noise emitted by it or hot air from its air outlet will cause no nuisance to your neighbors.
- If the air conditioner sounds abnormal during operation, contact the dealer where you purchased the air conditioner.

### **Wire**

- To avoid the electric shock, please link the air conditioner with the ground. The power cord to the air conditioner has ground wiring, please do not alter.
- Do not pull the power wiring hard.
- When grounding the air conditioner, observe the local rules.
- Use the correct fuse or circuit breaker.
- If you want to change the power wiring, please contact your contractor.

### **Relocation**

If you move out or if it is desired to relocate the air conditioner, consult your dealer. Special skills to withdraw Freon, purge air and perform other operations are required.

## TROUBLESHOOTING

Before you ask for servicing or repairs, check the following points.

### Recheck

#### Inoperative

- The power fuse is blown or the circuit breaker has been tripped.
- The batteries in the remote controller are exhausted.
- The timer is set.

#### Does not cool or heat well.

- The air inlet or outlet of the outdoor unit is blocked.
- Doors or windows are open.
- The air filter is clogged with dust.
- The louver is not at the correct position.
- The fan speed is set to low.
- The temperature setting is too high or too low.

### These are not failures

#### Room air is smelly.

A bad odor comes from the air conditioner.

- Smells impregnated in the wall, carpet, furniture, clothing, or furs, are coming out. A white mist of chilled air or water is generated from the outdoor unit.

### CAUTION

If any of the following conditions occur, stop the air conditioner immediately, set to off the power switch, and contact the dealer:

- The indicator lamps flash rapidly (five times per second), you disconnect the unit with the power and then connect the unit with the power again after two or three minutes but the lamps still flash.
- Switch operations are erratic.
- The fuse is blown frequently or the circuit breaker is tripped frequently.
- Foreign matter or water has fallen inside the air conditioner.
- Any other unusual condition is observed.

## TROUBLESHOOTING (CONCERNING REMOTE CONTROLLER)

Before you ask for servicing or repairs, check the following points.

Setting Change is Impossible		
Symptoms	Causes	Reason and Disposal
The fan speed can not be changed.	<ul style="list-style-type: none"> <li>• Check whether the MODE indicated on the display is "AUTO"</li> </ul>	When the automatic mode is selected, the air conditioner automatically selects the fan speed.
	<ul style="list-style-type: none"> <li>• Check whether the MODE indicated on the display is "DRY"</li> </ul>	When dry operation is selected, the air conditioner automatically select the fan speed. The fan speed can be selected during "COOL" and "FAN ONLY", and "HEAT"

The Transmission Indicator "▲" Never Comes On		
Symptoms	Causes	Reason and Disposal
The remote control signal is not transmitted even when the ON/OFF button is pushed.	<ul style="list-style-type: none"> <li>• Check whether the batteries in the remote controller are exhausted.</li> </ul>	The remote control signal is not transmitted, because the power supply is off.

The Display Never Comes On		
Symptoms	Causes	Reason
The TEMP. indicator does not come on.	<ul style="list-style-type: none"> <li>• Check whether the MODE indicated on the display is "FAN ONLY". <b>FAN ONLY</b></li> </ul>	The temperature cannot be set during fan only operation.

The Display Goes Off		
Symptoms	Causes	Reason
The indication on the display disappears after a lapse of time.	<ul style="list-style-type: none"> <li>• Check whether the timer operation has come to an end when the OFF TIMER is indicated on the display.</li> </ul>	The air conditioner operation stops since the set time elapsed.
The ON TIMER indicators go off after a lapse of certain time.	<ul style="list-style-type: none"> <li>• Check whether the timer operation is started when the ON TIMER is indicated on the display.</li> </ul>	When the time set to start the air conditioner is reached, the air conditioner will automatically start and the appropriate indicator will go off.

The Signal Receiving Tone does Not Sound		
Symptoms	Causes	Disposal
No receiving tone sounds from the indoor unit even when the ON/OFF button is pushed.	<ul style="list-style-type: none"> <li>• Check whether the signal transmitter of the remote controller is properly directed to the receiver of the indoor unit when the ON/OFF button is pushed.</li> </ul>	Direct the signal transmitter of the remote controller to the receiver of the indoor unit, and then push the ON/OFF button twice.
Buttons on the remote controller don't work.		Press Reset button.

**The following displays indicate an error or problem:**

NO	Malfunction	Display (nixie tube)	timer lamp	running lamp (flashes per second)
1	<b>Indoor EEPROM error</b>	E0.	OFF	1
2	Communication malfunction between indoor and outdoor units	E1.	OFF	2
3	Indoor fan speed malfunction	E3.	OFF	4
4	Indoor room temperature sensor open circuit or short circuit	E4.	OFF	5
5	Evaporator coil temperature sensor open circuit or short circuit	E5.	OFF	6
6	Refrigerant leakage detection malfunction	EC.	OFF	7
7	Water-level alarm malfunction	EE.	OFF	8
8	Communication malfunction between two indoor units (for twins model)	E8.	OFF	N/A
9	Other malfunction of twins model	E9.	OFF	N/A
10	Current overload protection	F0.	ON.	1
11	Outdoor room temperature sensor open circuit or short circuit	F1.	ON.	2
12	Outdoor condenser pipe temperature sensor error	F2.	ON.	3
13	Discharging air temperature sensor error	F3.	ON.	4
14	Outdoor EEPROM error	F4.	ON.	5
15	Outdoor fan speed malfunction (Only for DC fan motor)	F5.	ON.	6
16	Lifting panel communication checking channel is abnormal	F7.	ON.	7
17	Lifting panel malfunction	F8.	ON.	8
18	Lifting panel is not closed	F9.	ON.	9
19	Inverter module IPM protection	P0.	Flash.	1
20	High/Low voltage protection	P1.	Flash.	2
21	High temperature protection of compressor top	P2.	Flash.	3
22	Outdoor low temp. Protection	P3.	Flash.	4
23	Compressor drive error	P4.	Flash.	5
24	Mode conflict	P5.	Flash.	6

The displayed error code differs from appliance to appliance. The actual display of the indoor unit shall prevail.



## LIMITED EXPRESS WARRANTY

Congratulations on purchasing your new HVAC equipment. It's been designed for long life and reliable service, and is backed by one of the strongest warranties in the industry. Your unit automatically qualifies for the warranty coverage listed below, providing you keep your proof of purchase (receipt) for the equipment and meet the warranty conditions.

### LIMITED FIVE (5) YEAR EXPRESS WARRANTY

Heat Controller warrants all parts of the VMH Series Ductless Mini-Split to be free from defects in workmanship and materials for normal use and maintenance for five (5) years from the date of purchase by the original consumer for the original installation. This Express Limited Warranty applies only when the Ductless Mini-Split is installed as a complete matched system: outdoor unit and indoor unit, and only when the system is installed per Heat Controller installation instructions and in accordance with all local, state and national codes for normal use.

### LIMITED 6th to 7th YEAR EXPRESS WARRANTY

The compressor only is warranted to be free from defects in workmanship and materials for normal use and maintenance for two (2) additional years, for a total of seven (7) years from the date of purchase by the original consumer for the original installation. This Express Limited Warranty applies only when the Ductless Mini-Split is installed as a complete matched system: outdoor unit and indoor unit, and only when the system is installed per Heat Controller installation instructions and in accordance with all local, state and national codes for normal use.

### EXCEPTIONS

The Limited Express Warranty does not cover normal maintenance—Heat Controller recommends that regular inspection/maintenance be performed at least once a season and proof of maintenance be kept. Additionally, labor charges, transportation charges for replacement parts, replacement of refrigerant or filters, any other service calls/repairs are not covered by this Limited Warranty. It also does not cover any portion or component of the system that is not supplied by Heat Controller, regardless of the cause of failure of such portion or component.

### CONDITIONS FOR WARRANTY COVERAGE

- Unit must be operated according to Heat Controller operating instructions included with the unit and cannot have been subjected to accident, alteration, improper repair, neglect or misuse, or an act of God (such as a flood)
- Installation was done by a trained, licensed or otherwise qualified HVAC dealer/contractor
- Performance cannot be impaired by use of any product not authorized by Heat Controller, or by any adjustments or adaptations to components
- Serial numbers and/or rating plate have not been altered or removed
- Damage has not been a result of inadequate wiring or voltage conditions, use during brown-out conditions, or circuit interruptions
- Air flow around any section of the unit has not been restricted
- Unit remains in the original installation
- Unit was not purchased over the internet

Please visit [www.heatcontroller.com](http://www.heatcontroller.com) to register your new product



### DURATION OF WARRANTY & REGISTRATION

The warranty begins on the date of purchase by the original consumer. The consumer must retain a receipted bill of sale as proof of warranty period. Without this proof, the express warranty begins on the date of shipment from the factory.

### REMEDY PROVIDED BY THE LIMITED EXPRESS WARRANTY

The sole remedy under the Limited Warranty is replacement of the defective part. If replacement parts are required within the period of this warranty, Heat Controller replacement parts shall be used; any warranty on the replacement part(s) shall not affect the applicable original unit warranty. Ready access to the unit for service is the owner's responsibility. Labor to diagnose and replace the defective part is not covered by this Limited Express Warranty. If for any reason the replacement part/product is no longer available during the warranty period, Heat Controller shall have the right to allow a credit in the amount of the current suggested retail price of the part/product instead of providing repair or replacement.

### LIMITATION OF LIABILITY

1. There are no other express or implied warranties. Heat Controller makes no warranty of merchantability. We do not warrant that the unit is suitable for any particular purpose or can be used in buildings or rooms of any particular size or condition except as specifically provided in this document. There are no other warranties, express or implied, which extend beyond the description in this document.
2. All warranties implied by law are limited in duration to the seven-year term of the parts warranty. Your exclusive remedy is limited to the replacement of defective parts. **We will not be liable for any consequential or incidental damages caused by any defect in this unit.**
3. This warranty gives you specific legal rights and you may also have other rights which vary from state to state. Some states do not allow limitation on how long an implied warranty lasts or do not allow the exclusion or limitation of incidental or consequential damages, so the above limitations or exclusions may not apply to you.
4. No warranties are made for units sold outside the continental United States and Canada. Your distributor or final seller may provide a warranty on units sold outside these areas.
5. Heat Controller will not be liable for damages if our performance regarding warranty resolution is delayed by events beyond our control including accident, alteration, abuse, war, government restrictions, strikes, fire, flood, or other acts of God.

### HOW TO OBTAIN WARRANTY SERVICE OR PARTS

If you have a warranty claim, notify your installer promptly. If the installer does not remedy your claim, write to Heat Controller, 1900 Wellworth Ave., Jackson MI 49203. Enclose a report of inspection by your installer or service person. Include model number, serial number, and date of purchase.

Owner responsibilities are set forth in the instruction manual—read it carefully.

### KEEP THIS INFORMATION AS A RECORD OF YOUR PURCHASE

Outdoor Unit: Model No. \_\_\_\_\_ Serial No. \_\_\_\_\_

Indoor Unit 1: Model No. \_\_\_\_\_ Serial No. \_\_\_\_\_

Indoor Unit 2: Model No. \_\_\_\_\_ Serial No. \_\_\_\_\_

Indoor Unit 3: Model No. \_\_\_\_\_ Serial No. \_\_\_\_\_

Indoor Unit 4: Model No. \_\_\_\_\_ Serial No. \_\_\_\_\_

Indoor Unit 5: Model No. \_\_\_\_\_ Serial No. \_\_\_\_\_

Date of Purchase \_\_\_\_\_

---

Due to ongoing product improvements, specifications and dimensions are subject to change and correction without notice or incurring obligations. Determining the application and suitability for use of any product is the responsibility of the installer. Additionally, the installer is responsible for verifying dimensional data on the actual product prior to beginning any installation preparations.

Incentive and rebate programs have precise requirements as to product performance and certification. All products meet applicable regulations in effect on date of manufacture; however, certifications are not necessarily granted for the life of a product. Therefore, it is the responsibility of the applicant to determine whether a specific model qualifies for these incentive/rebate programs.

*Comfort-Aire*®  **Century**®