Comfort-Cire®

Century®

PARTS LIST

Thru-the-Wall

BGE-143R01

EXPLODED VIEW

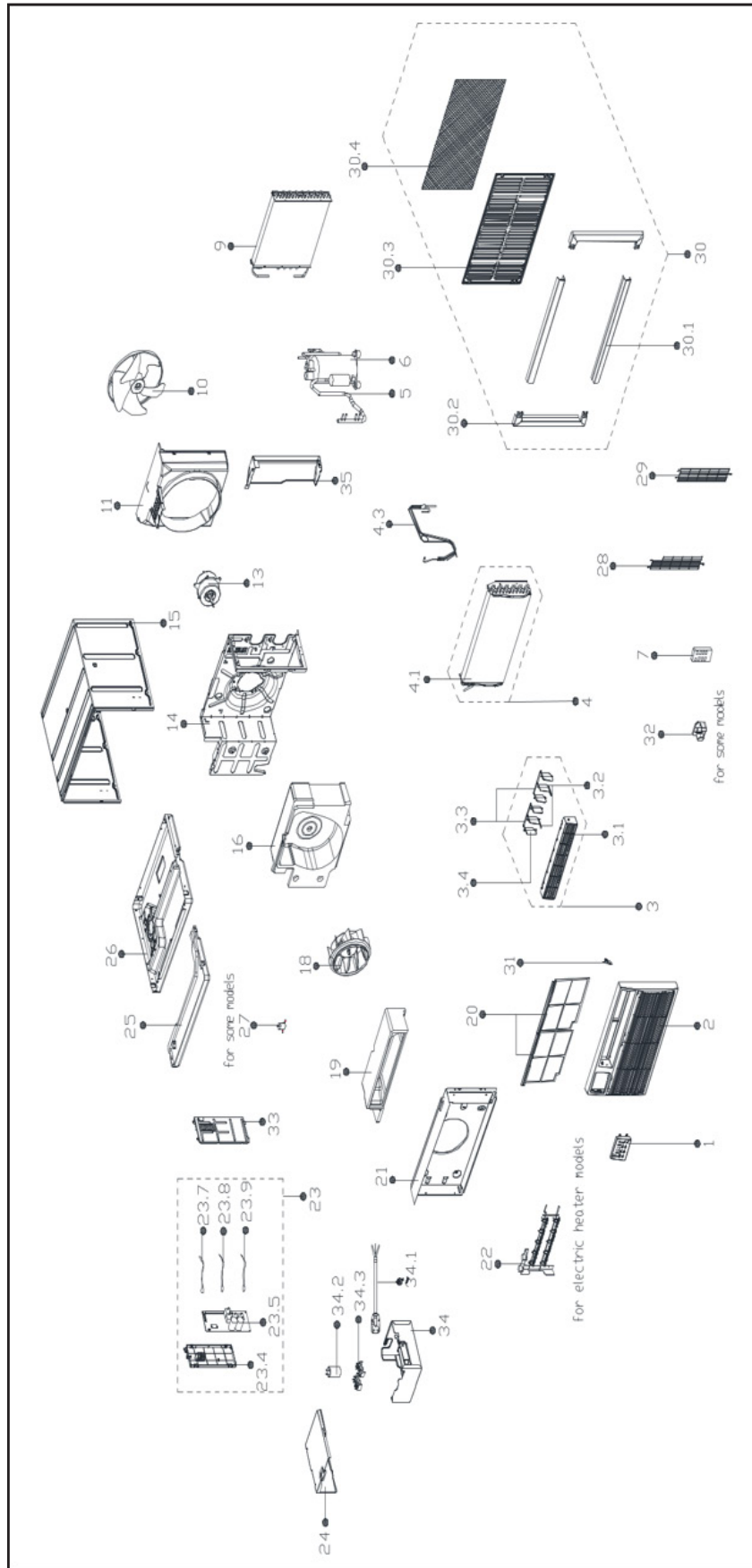

REPLACEMENT PARTS

Location	Part Name	Quantity	Part No.
1	Display box subassembly	1.00	17220300A24422
2	Panel	1.00	12120300A22046
3	Air outlet assembly	1.00	12120300A22039
3.1	Air outlet frame	1.00	12120300006745
3.2	Horizontal louver	2.00	12120300006765
3.3	Connecting rod of louver	2.00	12120300006767
3.4	Horizontal louver	6.00	12120300006766
4	Evaporator assembly	1.00	15820300004325
4.1	Evaporator	1.00	15820300003465
4.3	Capillary subassembly	1.00	15120300007425
5	Discharge pipe assembly	1.00	15120300008262
6	Fixed Speed Rotary Compressor	1.00	11103010021756
7	Remote controller	1.00	17317000A66669
8	Cooling coil assembly	1.00	15120300002830
9	Condenser Assembly	1.00	15820300002512
10	Axial flow fan	1.00	12100105000053
11	Rear barrier board subassembly	1.00	12120300007104
13	Brushless DC Motor	1.00	11002015018252
14	Front separating board subassembly	1.00	12220300005639
15	Cabinet	1.00	12220300003939
16	Foam of rear volute shell subassembly	1.00	12820300000879
18	Centrifugal Fan	1.00	12100103000030
19	Foam, air outlet	1.00	12820300000899
20	Filter	1.00	12120300A23728
21	Installation plate of Electric heater subassembly	1.00	12220300005618
22	strip heater	1.00	17402004001579
23	Electronic control box subassembly	1.00	17220300A24255
23.4	Bracket of main control board	1.00	12120300007106
23.5	Main control board subassembly	1.00	17120300A05823
23.7	Pipe Temperature Sensor	1.00	11201007003441
23.8	Room Temperature Sensor	1.00	11201007003563
23.9	Discharge Temperature Sensor	1.00	11201007006905
24	Electronic Control Box Cover Subassembly	1.00	12220300001092
25	Foam	1.00	12820300000059
26	Chassis assembly	1.00	12220300005840
27	Drain valve	1.00	17400510000003
28	Rear Protective Net	1.00	12220300001104
29	Rear Protective Net	1.00	12220300001103
30	Installation accessory	1.00	12020300A02884
30.1	Top shutter frame	2.00	12120300004665
30.2	Right shutter frame	2.00	12120300004664
30.3	Air inlet grille	1.00	12920300000001
30.4	Net	1.00	12120300001299
31	Filter guide	1.00	12120300007124
33	Electronic control box cover subassembly	1.00	12220300005638
34	Electronic control box subassembly	1.00	17220300005950
34.1	American standard power cord	1.00	17401202016227
34.2	Compressor Capacitor	1.00	17400103000055
34.3	Terminal	2.00	17400401000012
35	Rear panel assembly	1.00	12220300005619

Due to ongoing product improvements, specifications and dimensions are subject to change and correction without notice or incurring obligations. Determining the application and suitability for use of any product is the responsibility of the installer. Additionally, the installer is responsible for verifying dimensional data on the actual product prior to beginning any installation preparations.

Incentive and rebate programs have precise requirements as to product performance and certification. All products meet applicable regulations in effect on date of manufacture; however, certifications are not necessarily granted for the life of a product. Therefore, it is the responsibility of the applicant to determine whether a specific model qualifies for these incentive/rebate programs.



1900 Wellworth Ave., Jackson, MI 49203 • Ph. 517-787-2100 • www.heatcontroller.com