

Comfort-Aire®

Our 42" packaged terminal air conditioners and heat pumps provide year 'round comfort, room by room, for hotels, motels, apartments, office buildings, schools, nursing homes and more. Designed for quick installation in most 16" x 42" wall sleeves, they're great for new construction as well as replacements.

Combining attractive appearance with state-of-the art technology, these units minimize energy usage while ensuring guest comfort. Available in cooling only and heat pump versions, all models include electric heat as standard.

For installation flexibility, the unit is designed to be controlled either by on-board control panel or by a wired remote thermostat. A plug-in adapter for this thermostat is included. The unit can also be set up for a wireless thermostat or front desk control with easy-to-connect interface.

All functions of the unit can be controlled in-room using the easy-to-understand touchpad. LEDs correspond to mode and fan operation, indicating unit status, and the setpoint temperature is adjusted with up and down arrows—60 to 90° F.

The unit is protected by an anti-short cycle function that helps prolong compressor life. Also random restart prevents all units from starting at the same time following a power outage.

FEATURES

- **Standard Efficiency**—Provides energy efficiency and economy of cost in a streamlined and attractive modern design showcasing state-of-the-art features.
- **Environmentally Friendly**—Our packaged terminal units come charged with the environmentally friendly R-32 refrigerant
- **Room Freeze Protection**—When the unit senses temperatures 50°F or lower for three minutes, heat pump models automatically activate the heating mode
- **Versatile Configuration**—The unit can be optimized to a specific application through the use of dipswitches and the digital keypad; selections include setpoint limiting, front desk control, wall thermostat control, and more
- **Quiet Operation**—Indoor sound reduction is achieved through the unit's two permanently lubricated fan motors; compressor has rubber grommet mounting
- **Fresh Air Control Arm**—Allows outdoor air into room through filtered vent, 85 CFM
- **Easy To Service**—On-board computer diagnostics help prolong the life of the unit and simplify service; LED indicator flashes error codes
- **Seacoast models**—with corrosion resistant components, see specifications inside

42PT-H SERIES

PACKAGED TERMINAL AC/HP

PTAC - Cooling only with Electric Heat

PTHP - Heat Pump with Electric Heat

7,000 to 15,000 BTUH



Warranty—5 years on compressor, 5 years on parts
See warranty document for details or visit;
www.comfort-aire.com



MODEL NOMENCLATURE

PT	AC	12	H	1	30	A
Package Terminal Unit with Electric Heat	AC = Cooling Only HP = Heat Pump	Capacity BTUH x 1000	Source Code	Power 1 = 208/230-1-60 2 = 265-1-60	Electric Heat 30 = 3.0 kW 50 = 5.0 kW	Series/ Revision

PERFORMANCE AND ELECTRICAL DATA

208/230V COOLING ONLY WITH ELECTRIC HEAT

FEATURE	PTAC07G130A	PTAC09G130A	PTAC12G130A	PTAC12G150A	PTAC15G130A	PTAC15G150A
Cooling BTUH	7,200/7,300	9,000/9,200	11,800/12,000	11,800/12,000	14,500/14,700	14,500/14,700
EER	13.1	11.3	10.7	10.7	10.6	10.6
Cooling Amps	3.1/3.4	4.3/4.9	5.5/6.1	5.5/6.1	7.5/8.9	7.5/8.9
Max. Current Amps	3.6	5.2	7.7	7.7	11.0	11.0
Cooling Watts	550/560	780/790	1,060/1,080	1,060/1,080	1,370/1,390	1,370/1,390
Electric Heater kW @ 208/230	2,150/2,580	2,897/3,500	2,897/3,500	4,100/5,000	2,897/3,500	4,100/5,000
Elec. Heat BTUH @ 230V	6,300/7,800	8,900/10,900	8,900/10,900	12,200/15,000	8,900/10,900	12,200/15,000
Dehum. Pts/Hr	LCDI (6-20P)	LCDI (6-20P)	LCDI (6-20P)	LCDI (6-30P)	LCDI (6-20P)	LCDI (6-30P)
Power Cord	346	430	432	432	431	431
Airflow CFM	51	50	52	52	51	51
Indoor Sound Max dB(A)	67	63	67	67	65	65
Out. Sound Max dB(A)	98/107	97/106	104/113	104/113	106/115	106/115
Net Wt./Shipping Wt.	91.50/102.52	93.70/104.72	105.82/116.85	105.82/116.85	95.90/117.95	95.90/117.95

208/230V HEAT PUMP WITH ELECTRIC HEAT

FEATURE	PTHP07G130A	PTHP09G130A	PTHP12G130A	PTHP12G150A	PTHP15G130A	PTHP15G150A
Cooling BTUH	7,100/7,200	9,200/9,300	11,800/12,000	11,800/12,000	14,500/14,700	14,500/14,700
EER	13.1	11.4	10.5	10.5	10.6	10.6
Cooling Amps	3.0/3.3	4.2/4.6	5.3/5.8	5.3/5.8	6.5/7.4	6.5/7.4
Max. Current Amps	3.6	5.2	8.0	8.0	11.0	11.0
Cooling Watts	540/550	810/820	1,020/1,040	1,020/1,040	1,370/1,390	1,370/1,390
Heat Pump BTUH	6,000/6,200	7,900/8,100	10,500/10,800	10,500/10,800	13,200/13,500	13,200/13,500
C.O.P. @ 47°F	3.60	3.40	3.20	3.20	3.20	3.20
Heating Amps	2.6/2.7	3.9/4.3	5.0/5.3	5.0/5.3	6.0/6.4	6.0/6.4
Heating Watts	460/480	690/720	850/890	850/890	1,120/1,170	1,120/1,170
Electric Heater kW @ 208/230	2,150/2,580	2,897/3,500	2,897/3,500	4,100/5,000	2,897/3,500	4,100/5,000
Elec. Heat BTUH @ 230V	6,300/7,800	8,900/10,900	8,900/10,900	12,200/15,000	8,900/10,900	12,200/15,000
Power Cord	LCDI (6-20P)	LCDI (6-20P)	LCDI (6-20P)	LCDI (6-30P)	LCDI (6-20P)	LCDI (6-30P)
Dehum. Pts/Hr	355	364	439	439	417	417
Airflow CFM	51	50	52	52	53	53
Indoor Sound Max. dB(A)	67	64	67	67	67	67
Out. Sound Max dB(A)	102/111	100/108	111/119	111/119	114/123	114/123
Net Wt./Shipping Wt.	92.59/103.62	94.80/105.82	95.90/117.95	95.90/117.95	108.03/119.05	108.03/119.05

DIMENSIONS

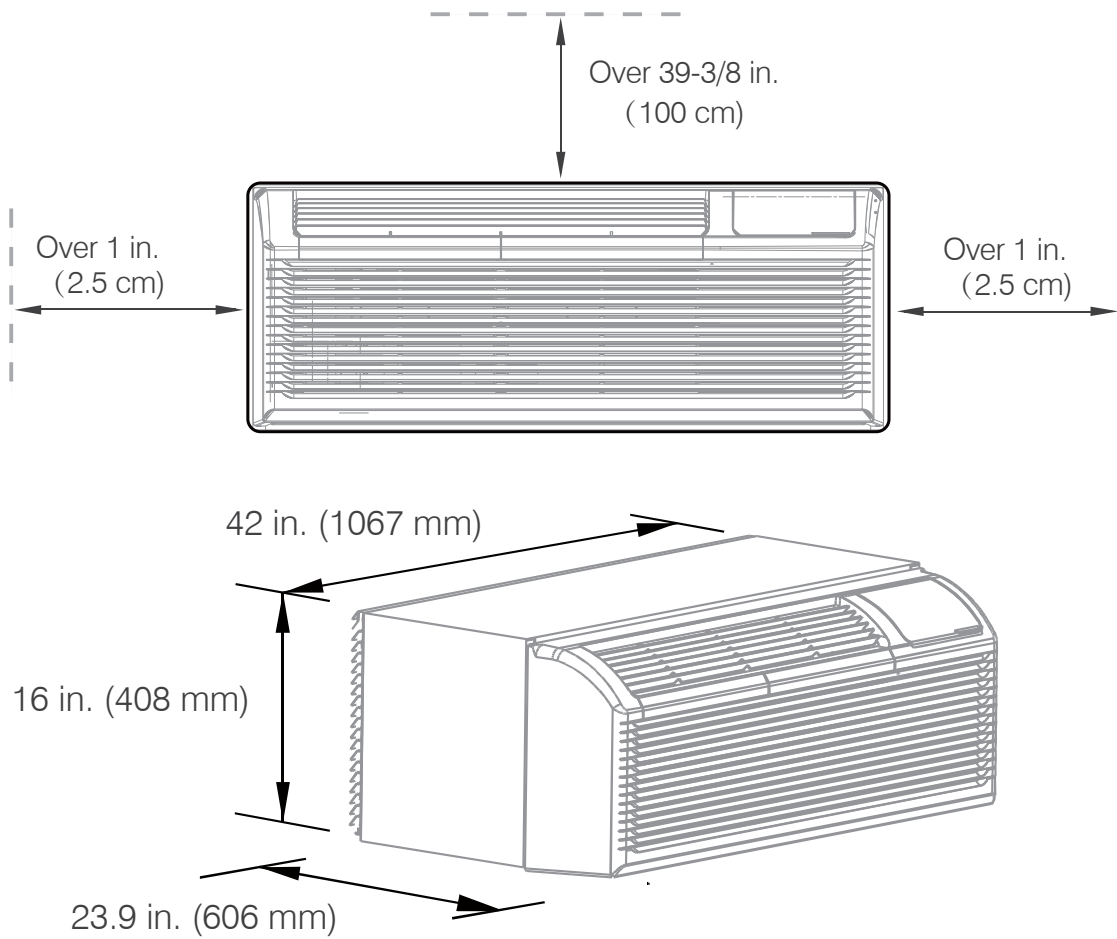

OPERATING VOLTAGE

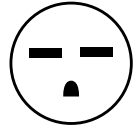

230/208V 15 Amp

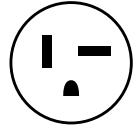

230/208V 20 Amp

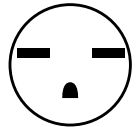

230/208V 30 Amp

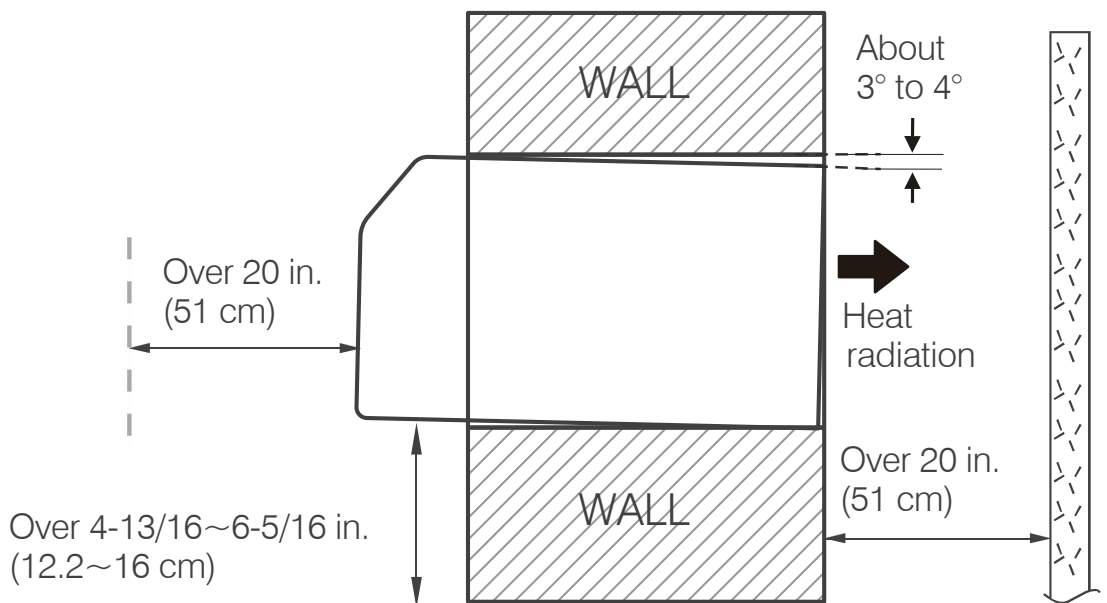

UNIT DIMENSIONS

42" W • 16" H • 21.1" D (without sleeve)



The two-piece filter design provides enhanced air filtration. Conveniently located on the front of the unit, filters can be easily removed for cleaning.

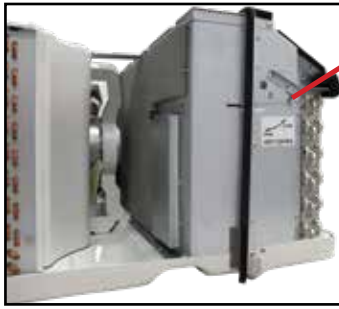

The fresh air control arm allows outdoor air into the room through the vent filter. Closing the vent door allows air inside the room to be circulated and filtered.

OPERATING VOLTAGE



230/208V 15 Amp



230/208V 20 Amp



230/208V 30 Amp

PERFORMANCE AND ELECTRICAL DATA

208/230V COOLING ONLY WITH ELECTRIC HEAT—SEACOAST MODELS

FEATURE	PTAC12H130ASC	PTAC12H150ASC	PTAC15H130ASC	PTAC15H150ASC
Cooling BTUH	11,800/12,000	11,800/12,000	14,300/14,500	14,300/14,500
EER	10.8/10.5	10.8/10.5	10.0/10.2	10.0/10.2
Cooling Amps	5.4/5.1	5.4/5.1	7.0/6.4	7.0/6.4
Max. Current Amps	7.3	7.3	8.9	8.9
Cooling Watts	1100/1140	1100/1140	1450/1470	1450/1470
Electric Heater kW @ 208/230	3.0	5.0	3.0	5.0
Elec. Heat BTUH @ 230V	10236	17060	10236	17060
Dehum. Pts/Hr	2.32	2.32	3.59	3.59
Power Cord	20A 6-20 P	30A 6-30 P	20A 6-20 P	30A 6-30 P
Airflow CFM	405/333	405/333	405/370	405/370
Indoor Sound Max dB(A)	48/42	48/42	48/45	48/45
Out. Sound Max dB(A)	66	66	66	66
Net Wt./Shipping Wt.	108/121	108/121	112/126	112/126

For installations in or near coastal locations, 12,000 and 15,000 BTUH models are available in a "Seacoast" version built to withstand such extreme conditions. Corrosion resistant coatings are applied to components, including the condenser fins, outdoor fan motor enclosure, base pan, and back grille.

Additional corrosion protection is provided by stainless steel screws and aluminum end plates.

Treated outdoor sections successfully meet 48-hour salt spray test requirements, as well as anti-rust testing.

Seacoast models meet the same stringent performance specifications as all our PTACs/PTHPs, and are designated by "SC" at the end of the part number.

208/230V HEAT PUMP WITH ELECTRIC HEAT—SEACOAST MODELS

FEATURE	PTHP12H130ASC	PTHP12H150ASC	PTHP15H130ASC	PTHP15H150ASC
Cooling BTUH	11,800/12,000	11,800/12,000	14,300/14,500	14,300/14,500
EER	10.6/10.5	10.6/10.5	10.0/10.2	10.0/10.2
Cooling Amps	5.4/5.1	5.4/5.1	6.8/6.3	6.8/6.3
Max. Current Amps	7.3	7.3	8.9	8.9
Cooling Watts	1100/1140	1100/1140	1400/1420	1400/1420
Heat Pump BTUH	10,800/11,000	10,800/11,000	13,200/13,600	13,200/13,600
C.O.P. @ 47°F	3.50/3.30	3.50/3.30	3.30/3.30	3.30/3.30
Heating Amps	4.5/4.2	4.5/4.2	5.6/5.2	5.6/5.2
Heating Watts	900/950	900/950	1155/1180	1155/1180
Electric Heater kW @ 208/230	3.0	5.0	3.0	5.0
Elec. Heat BTUH @ 230V	10236	17060	10236	17060
Power Cord	20A 6-20 P	30A 6-30 P	20A 6-20 P	30A 6-30 P
Dehum. Pts/Hr	2.32	2.32	3.59	3.59
Airflow CFM	405/333	405/333	405/370	405/370
Indoor Sound Max. dB(A)	48/42	48/42	48/45	48/45
Out. Sound Max dB(A)	66	66	66	66
Net Wt./Shipping Wt.	110/123	110/123	112/126	112/126

*Power cord not included



FEATURES

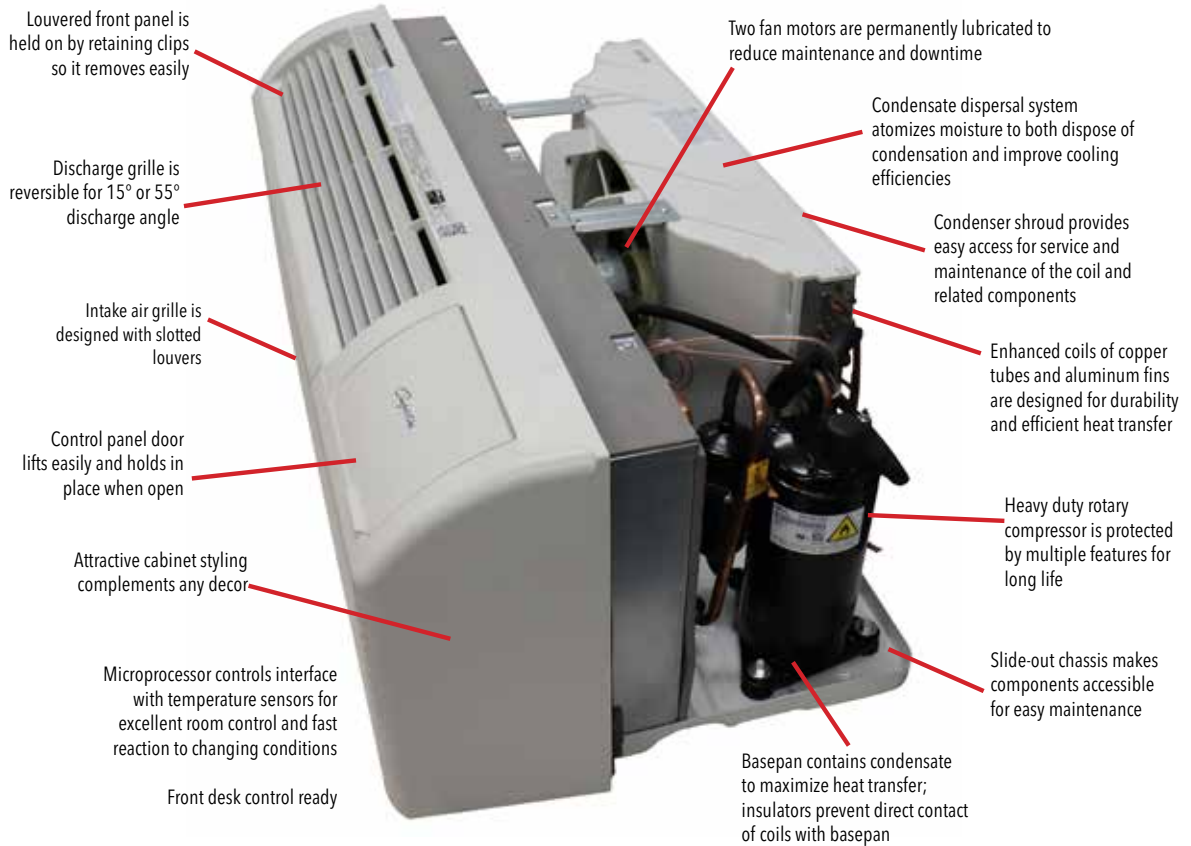

OUTSTANDING WARRANTY COVERAGE

All Comfort-Aire PTACs/PTHPs are covered by a one year parts and labor warranty. In addition, the sealed system and all functional parts are warranted to be free from defects in material and workmanship for a total of five years. See our website for warranty details.

PTAC/PTHP ACCESSORIES

Breakdown Wall Sleeve

Part No. 7602-500F - Galvanized Steel

Part No. 7602-500PF - Polymer

Our 42" wall sleeve is constructed from galvanized steel and powder coated for durability and aesthetic appeal. The wall sleeve is insulated and factory spot welded to minimize breaches in the cabinet surface. It contains four chassis mounting holes, four grille mounting holes and two drain holes for optional drain kit.

Dimensions W x H x D (inches)

42" x 16" x 14⁷/₈"



Air Deflector

Part No. 7602-508F

The PTAC Air Deflector directs air up and away from overhanging drapes. It saves energy by eliminating trapped air flow between the window and the curtain while increasing guest comfort levels. It is easy to install with no tools needed.



PTAC/PTHP ACCESSORIES

Sub Base

Part No. 7602-509F - Unpowered

Part No. 7602-509F-20A - 20 Amp Receptical

Part No. 7602-509F-30A - 30 Amp Receptical

Made from galvanized steel and powder coated, our sub-base has only one piece, plus the skirting, for faster and more economical installation. Each kit contains: Sub-base main body, left and right side skirt, adjusting feet, and installation instructions.



Dimensions W x H x D (inches)

42³/₈" x 3³/₄" x 4⁵/₈"

Stamped Grille

Part No. 7602-501F

Our stamped grille is made from durable, light weight aluminum and made to fit a standard 42" wall sleeve. Vents match our units to facilitate proper airflow, and must used with Comfort-Aire® PTACs.



Grilles match our units to facilitate proper airflow, and must used with Comfort-Aire® PTACs.

Dimensions W x H x D (inches)

41⁷/₈" x 15³/₈" x 3³/₈"

Architectural Grille

Part No. 7602-505F

Our architectural grille fits a standard 42" wall sleeve. It's formed from durable aluminium for weight reduction and weather resistance and powder coated for greater durability. Louvers are connected with high tensile rods. The grille comes factory assembled and includes four attachment points and two discharge air shaping deflectors.



Grilles match our units to facilitate proper airflow, and must used with Comfort-Aire® PTACs.

Dimensions W x H x D (inches)

42" x 15³/₄" x 1³/₈"

Polymer Grille

Full polymer grille with stainless steel hardware is ideal for any location where corrosion is an issue, especially coastal areas. Available in white, beige, alpine beige, and dark bronze.

Dimensions W x H x D (inches)

42" x 15⁷/₈" x 1¹/₈"



Ultra White: 7602-505UWF

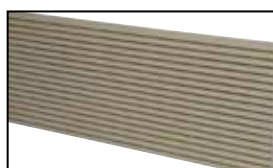

Beige: 7602-505PBF

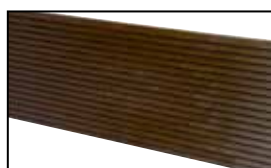

Dark Bronze: 7602-505PDF



Alpine Beige: 7602-505PAF



White: 7602-505PWF

Photos may not portray actual color.

Grilles match our units to facilitate proper airflow, and must used with Comfort-Aire® PTACs.

PTAC/PTHP ACCESSORIES

Thermostat

Part No. 7800-200 - used with PTAC

Part No. 7800-201 - used with PTHP

This thermostat is a digital, mercury free, wired, non-programmable, electronic thermostat, compatible with PTAC/PTHP models.

Dimensions W x H x D (inches)

4¹/₂" x 3³/₄" x 1¹/₁₆"



*appearance may vary

Wireless Wall Thermostat

Part No. 7602-536A

This thermostat operates our PTAC/PTHP line, without the need to run control wires. Contains all basic thermostat functions.

Dimensions W x H x D (inches)

4⁵/₈" x 3³/₄" x 1"



Lock Cover

Part No. 7602-535

Designed for use with duct kits, where control access is not available, or any situation where wired or wireless remote system control is desired or restricted access is required. Key access is provided for service.

Shipping Dimensions W x H x D (inches)

7⁷/₈" x 7⁷/₈" x 2¹/₆₄"



Drain Kit

Part No. 7602-506F

The drain kit, including both 90° drain tube and a 180° drain tube, can be used for either an internal or external drain and can be attached to one of two available outlets on the wall sleeve. The mounting plates are made from galvanized steel and powder coated to match the wall sleeve.

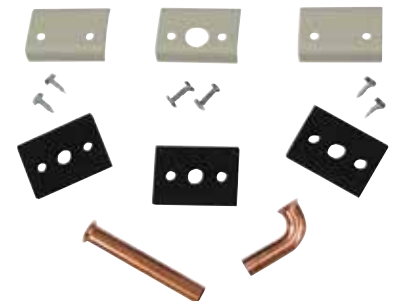

Comfort-Cire®

PTAC/PTHP ACCESSORIES

Main Duct Kit

Part No. 7602-511F

The lateral duct kit contains everything needed to convert a PTAC or PTHP for heating/cooling an adjacent room. The one-piece plenum attaches to the wall sleeve with brackets (included) and fits over the unit's air discharge grille. The extension duct can be installed for left or right side duct applications, with a maximum extension of 4 feet. Both the plenum and the duct extension are constructed of galvanized steel with a painted finish, and they are fully lined with insulation. The air volume baffle can be adjusted to allow a 75/25 to 80/20 airflow split between the primary and secondary (adjacent) rooms. In addition to the plenum, extension duct and brackets, the kit includes a wall register, wall trim kit, end cap, hardware and instructions.

Dimensions

Plenum: 44¹/₁₆" W x 7¹/₈" D x 7¹/₂" H (tallest point)

Extension: 47⁵/₁₆" W x 7" D x 3¹/₂" H

Wall Register: 8¹/₂" W x 5¹/₄" H



Plenum

Duct Extension



Wall Register



Trim Kit



PTAC models in this brochure are certified directly with the United States Dept. of Energy (D.O.E.) as meeting specifications shown.



"This product complies with all California product labeling laws including, but not limited to, the Safe Drinking Water and Toxic Enforcement Act of 1986, more commonly known as Proposition 65."

Due to ongoing product improvements, specifications and dimensions are subject to change and correction without notice or incurring obligations. Determining the application and suitability for use of any product is the responsibility of the installer. Additionally, the installer is responsible for verifying dimensional data on the actual product prior to beginning any installation preparations. Third party incentive and rebate programs have precise requirements as to product performance and certification. All products meet applicable regulations in effect on date of manufacture; however, certifications are not necessarily granted for the life of a product. Therefore, it is the responsibility of the applicant to determine whether a specific model qualifies for these incentive/rebate programs.