



Portable Cube Dehumidifiers

A new "twist" on Dehumidification!

Historically, home dehumidifiers have been ungainly, top-heavy machines. Conspicuous and with limited aesthetic appeal, dehumidifiers were nothing to get excited about. Until now.

Introducing the Comfort-Aire Cube: A radical re-thinking of what consumers should expect from a modern dehumidifier. Beginning with a sleek and compact design, the **Cube** dehumidifier ships and stores in its own tank - reducing shipping requirements, storage area, and shelf-space in one unique feature. To engage, simply lift the **Cube** dehumidifier from the tank using the convenient handle, and twist - setting the dehumidifier squarely on top of the tank. You are now ready to turn your home into the comfortable and efficient environment you deserve.



FEATURES

- 115V
- 24 hour timer
- Auto restart
- Electronic controls
- Low temperature operation
- Automatic Water Level Shut-Off
- Pump Lift (BCDP-50A)
- Energy Star Certified
- Casters for easy portability
- Smartphone compatible

Models

BCD-20A

BCD-35A

BCD-50A

BCDP-50A



Warranty

1 Year Unit Replacement Warranty*

*For details, visit www.comfort-aire.com



Portable Cube Dehumidifiers

20 Pint, 35 Pint, and 50 Pint Capacities



BCD-20A

20 pints/day

Bucket Capacity: 25 pints

SPECIFICATIONS

Capacity (pts per day)	20.04
Voltage	115V, 1ph, 60hz
Energy Factor L/kWH	1.7
Energy Star*	Yes
Input Watts/Amps	230/2.1
24 Hour On/Off Timer	Yes
Electronic Controls	Yes
Fan Speeds	2
Sound Level (dBa) (Hi/Mi/Lo)	44/42
Low Temp Operation	41F
Set/Room Humidity Display	Yes
Full Bucket/Auto Shut-Off	Yes
Auto Restart	Yes
Auto Defrost Control	Yes
Bucket Capacity	25 pints
Pump Lift	N/A
Dimension (inches) W x D x H	13.5 x 13.5 x 13.39
Net Weight (lbs.)	33.3
Ship Wt lbs.	36.2

BCD-35A

35 pints/day

Bucket Capacity: 33.8 pints

SPECIFICATIONS

Capacity (pts per day)	35.08
Voltage	115V, 1ph, 60hz
Energy Factor L/kWH	1.9
Energy Star*	Yes
Input Watts/Amps	345/3.1
24 Hour On/Off Timer	Yes
Electronic Controls	Yes
Fan Speeds	2
Sound Level (dBa) (Hi/Mi/Lo)	45/42.5
Low Temp Operation	41F
Set/Room Humidity Display	Yes
Full Bucket/Auto Shut-Off	Yes
Auto Restart	Yes
Auto Defrost Control	Yes
Bucket Capacity	33.8 pints
Pump Lift	N/A
Dimension (inches) W x D x H	14.76 x 14.45 x 14.57
Net Weight (lbs.)	41.1
Ship Wt lbs.	44.2

BCD-50A

50 pints/day

Bucket Capacity: 33.8 pints

SPECIFICATIONS

Capacity (pts per day)	49.58
Voltage	115V, 1ph, 60hz
Energy Factor L/kWH	1.95
Energy Star*	Yes
Input Watts/Amps	480/4.4
24 Hour On/Off Timer	Yes
Electronic Controls	Yes
Fan Speeds	2
Sound Level (dBa) (Hi/Mi/Lo)	49.5/48
Low Temp Operation	41F
Set/Room Humidity Display	Yes
Full Bucket/Auto Shut-Off	Yes
Auto Restart	Yes
Auto Defrost Control	Yes
Bucket Capacity	33.8 pints
Pump Lift	N/A
Dimension (inches) W x D x H	14.76 x 14.45 x 14.57
Net Weight (lbs.)	41.7
Ship Wt lbs.	45.2

Smart-Phone App

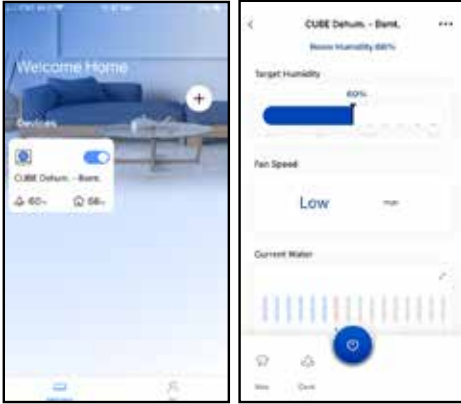

Additionally, the advanced smart-phone compatibility on the **Cube** gives real-time condensate levels for peace-of-mind, and customizable tank-alarms!

BCDP-50A with Built-In Pump

50 pints/day

Bucket Capacity: 33.8 pints



Minimalist Beauty

Note the minimalist design features that compliment any décor, making the **Cube** something to be proud of – not an appliance to hide. The **Cube** is not all about looks, however. Designed to stand over an existing floor drain for easy condensate removal, the **Cube** can also utilize the extra-large reservoir holding over **3 gallons** of condensate if a floor drain is not available. That is **4 times** the amount of capacity of typical dehumidifiers! Imagine allowing your dehumidifier to run for a week at a time without having to pour out the condensate. Emptying the tank is a cinch too – since the **Cube** tank is a bucket-design with an integral handle for easy lifting and pouring. Not at all like the small and awkward door tanks used on most dehumidifiers that spill while emptying.



Continuous Draining

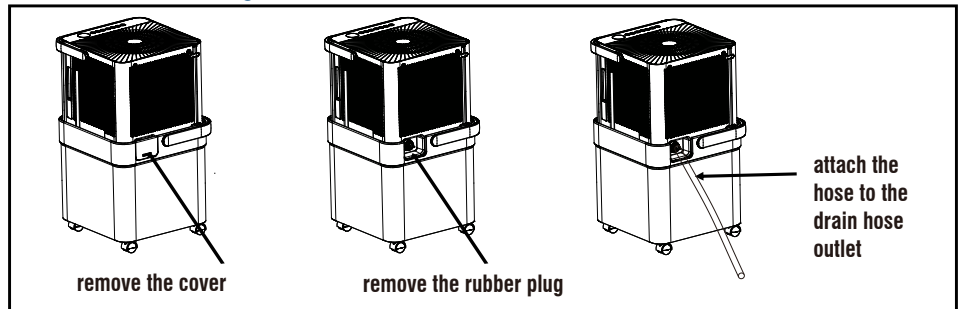

SPECIFICATIONS

Capacity (pts per day)	49.58
Voltage	115V, 1ph, 60hz
Energy Factor L/kWH	1.95
Energy Star®	Yes
Input Watts/Amps	480/4.4
24 Hour On/Off Timer	Yes
Electronic Controls	Yes
Fan Speeds	2
Sound Level (dBA) (Hi/Mi/Lo)	49.5/48
Low Temp Operation	41F
Set/Room Humidity Display	Yes
Full Bucket/Auto Shut-Off	Yes
Auto Restart	Yes
Auto Defrost Control	Yes
Bucket Capacity	33.8 pints
Pump Lift	16'
Dimension (inches) W x D x H	14.76 x 14.45 x 14.57
Net Weight (lbs.)	43
Ship Wt lbs.	46.7

Built-In Pump (BCDP-50A)

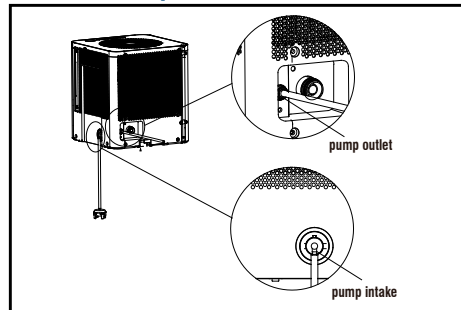

Pump Draining

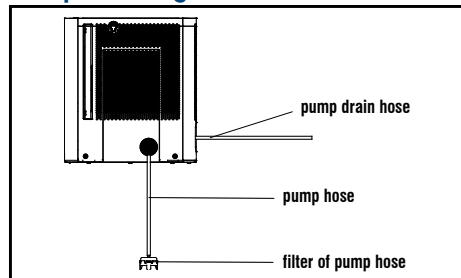

Easy Storage

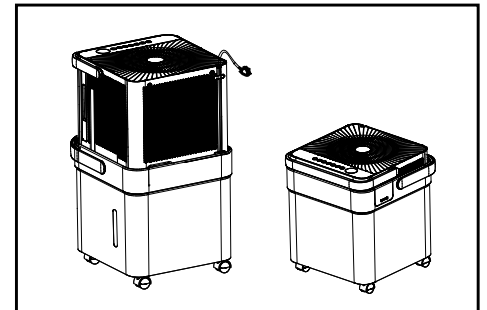

Cleaning the Air Filter

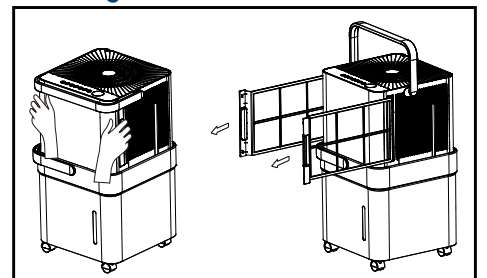



Portable Cube Dehumidifiers

20 Pint, 35 Pint, and 50 Pint Capacities

Dehumidifier Sizing Chart

Tabla de tallas del deshumidificador

Room Conditions <i>Condiciones de habitacion</i>	Square Footage of Space <i>Imágenes cuadradas del espacio</i>				
	500 sq. ft.	1,000 sq. ft.	1,500 sq. ft.	2,000 sq. ft.	2,500 sq. ft.
Mild Humidity- occasional damp feeling and musty odor <i>Humedad leve - Sensación de humedad ocasional y olor</i>	BCD-20A				
Moderately Humid- always damp and more pervasive musty odors <i>Moderadamente húmedo- Olores a humedad siempre húmedos y más percivos</i>		BCD-35A			
Very Humid- condensation stains/spots present, wet feeling, constant musty odor <i>Muy húmedo- Manchas / manchas de condensación presentes, sensación de humedad, olor a humedad constante</i>			BCD-50A, BCDP-50A		
Extreme Humidity- uncomfortably wet feeling, stains/spots, mold growth, constant musty odors <i>Humedad extrema- sensación de humedad incómoda, manchas / manchas, crecimiento de moho, olores constantes de mosto</i>					

Capacity needed is shown in pints per day, these are guidelines only.

Choosing the Proper Dehumidifier

Dehumidifier capacity is rated in pints per day (24 hour period). The table below is a guideline for the capacity necessary to dehumidify areas of various sizes and conditions.

Many variables can affect the amount of dehumidification required, including:

- Climate - hot, sticky conditions require extra capacity
- Number of people living in the space - the more people, the more capacity you'll need
- Number of doors and windows - lots of openings let in more moisture
- Operation of laundry equipment - washers and dryers add moisture to the air, and the more loads done each day, the greater the amount of moisture in the air

To use the table, decide which condition best describes the home or space, then find the size of the area to be dehumidified.

If there's any question about size, always choose the larger model. Remember - a unit can only remove moisture to its rated level. For dehumidification, oversizing is better than undersizing.

"This product complies with all California product labeling laws including, but not limited to, the Safe Drinking Water and Toxic Enforcement Act of 1986, more commonly known as Proposition 65."

Due to ongoing product improvements, specifications and dimensions are subject to change and correction without notice or incurring obligations. Determining the application and suitability for use of any product is the responsibility of the installer. Additionally, the installer is responsible for verifying dimensional data on the actual product prior to beginning any installation preparations.

Third party incentive and rebate programs have precise requirements as to product performance and certification. All products meet applicable regulations in effect on date of manufacture; however, certifications are not necessarily granted for the life of a product. Therefore, it is the responsibility of the applicant to determine whether a specific model qualifies for these incentive/rebate programs.