

RSG14**S1R

LE Series

SPECIFICATIONS

Compressor

- High-efficiency scroll compressor
- R410A refrigerant
- Heavy-duty compressor sound blanket for quiet operation (optional accessory)
- Internally protected against high temperature motor overload conditions

Cabinet

- Full metal louvered construction to protect the coil/ hail protection
- Individual louver panels; for ease of coil cleaning and service
- Corner-mounted controls for easy service
- Baked polyester paint finished over galvanized steel for maximum durability
- 45-degree offset valves for easy service

Coils

- Total corrosion protection technology designed coil
- Enhanced tube-and-fin coil design
- Lanced fins for maximum heat transfer
- Every coil factory tested for leakproof construction
- Raised coil prevents debris from impeding airflow

Components

- Factory installed high pressure switch
- Thread-on pressure switches for simple, quick replacement
- Filter drier shipped loose for installation flexibility
- Fan shroud for smoother airflow and sound level reduction
- Charged for 15 feet of line set

Comfort-Cire[®]

SPLIT AIR CONDITIONER SYSTEM

Minimum Efficiencies:
< 65Kbtu: 13.4 SEER2+



For the latest AHRI system matches,
please visit AHRIdirectory.org

MODEL NUMBER GUIDE

R	S	G	14	24	S	1	R
Residential Condenser	Split System	'Green' Gas R-410A	Minimum SEER	Capacity BTUH x 1000	S = Scroll Compressor	Power 1 = 208/230-1-60	Series/ Revision

PHYSICAL AND ELECTRICAL DATA

Model	Voltage/Hz/Phase	Voltage Range	Min. Circuit Amp.	Max. Over Current Device (amps)	Compressor		Outdoor Fan Motor		
					Rated Load (amps)	Locked Rotor (amps)	Full Load (amps)	Rated HP	Nom. RPM
RSG1418S1R	208-230/60/1	197-253	12.0	20	9.0	56.3	0.7	1/10	1075
RSG1424S1R	208-230/60/1	197-253	14.6	25	10.9	62.9	1.0	1/6	825
RSG1430S1R	208-230/60/1	197-253	17.0	25	12.8	67.0	1.0	1/6	825
RSG1436S1R	208-230/60/1	197-253	18.8	30	14.2	80.6	1.0	1/6	825
RSG1442S1R	208-230/60/1	197-253	21.9	35	16.7	113.0	1.0	1/6	825
RSG1448S1R	208-230/60/1	197-253	24.8	40	18.5	94.0	1.7	1/4	825
RSG1460S1R	208-230/60/1	197-253	29.6	50	22.2	127.9	1.8	1/3	825

Note:

Weights listed are unit weights with packaging + Factory charged for 15 feet of line set. Adjust per installation instructions.

UNIT DIMENSIONS & SOUND RATINGS

Model	Dimensions (inch)			Shipping Weight (Lbs.)
	A - Width	B - Depth	C - Height	
RSG1418S1R	24-1/4	24-1/4	29	134
RSG1424S1R	28-1/4	28-1/4	29	154
RSG1430S1R	28-1/4	28-1/4	37	169
RSG1436S1R	28-1/4	28-1/4	29	181
RSG1442S1R	28-1/4	28-1/4	37	211
RSG1448S1R	28-1/4	28-1/4	37	218
RSG1460S1R	32-1/4	32-1/4	43	226

Note:

Dimensions listed are unit sizes w/o packaging

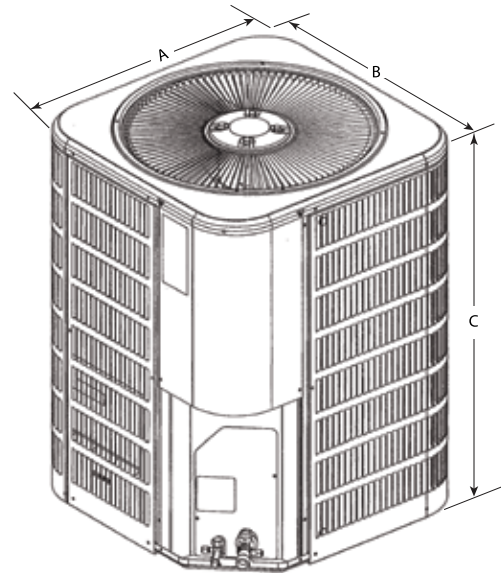

REFRIGERATION DATA

Model	Refrig. Charge (oz.) *	Piston Size	TXV	Refrigerant Line Size		Outdoor Unit Connection		Indoor Unit Connection	
				Suction	Suction	Suction	Suction	Suction	Liquid
RSG1418S1R	62	0.049	H4TXV01	3/4	3/8	3/4	3/8	3/4	3/8
RSG1424S1R	81	0.057	H4TXV01	3/4	3/8	3/4	3/8	3/4	3/8
RSG1430S1R	111	0.060	H4TXV01	3/4	3/8	3/4	3/8	3/4	3/8
RSG1436S1R	121	0.067	H4TXV02	7/8	3/8	7/8	3/8	7/8	3/8
RSG1442S1R	146	0.076	H4TXV02	7/8	3/8	7/8	3/8	7/8	3/8
RSG1448S1R	152	0.083	H4TXV02	7/8	3/8	7/8	3/8	7/8	3/8
RSG1460S1R	203	0.097	H4TXV03	1-1/8	3/8	7/8 **	3/8	7/8	3/8

*Factory charged for 15 feet of line set

** Adapter shipped with unit

COOLING PERFORMANCE WITH DTC¹

Outdoor Model	Indoor Model	Capacity (BTUH)	EER2	SEER2
RSG1418S1R	(C,M)CG24P(A,B,C)4P+TXV+TD	17,900	11	13.4
RSG1424S1R	(C,M)CG24P(A,B,C)4P+TXV+TD	23,600	11.7	13.4
RSG1430S1R	(C,M)CG36P(A,B,C)7P+TXV+TD	28,200	11.5	13.4
RSG1436S1R	(C,M)CG3036P(A,B,C)EP+TXV+TD	34,000	11.5	13.4
RSG1442S1R	(C,M)CG4248P(C,D)BP+TXV+TD	39,500	11	13.4
RSG1448S1R	(C,M)CG48P(B,C,D)FP+TXV+TD	45,500	11.5	13.4
RSG1460S1R	(C,M)CG60P(C,D)BP+TXV+TD	56,500	11.2	13.4

¹ DTC = Designated Tested Combination

SOUND RATINGS

Model	Sound Power ¹	Estimated Sound Pressure (dBA) ²		
		Approximate Distance ³		
		3.3 Feet (1 Meter)	6.6 Feet (2 Meters)	9.8 Feet (3 Meters)
RSG1418S1R	73	65	59	55
RSG1424S1R	76	68	62	58
RSG1430S1R	76	68	62	58
RSG1436S1R	76	68	62	58
RSG1442S1R	76	68	62	58
RSG1448S1R	78	70	64	60
RSG1460S1R	80	72	66	62

¹ Rated in accordance with AHRI standard 270 (2015). AHRI Standard 270 establishes a method of rating outdoor unitary equipment in terms of Sound Power.

² Rated in accordance with AHRI standard 275 (2010). AHRI Standard 275 provides the calculations for estimating the A-Weighted Sound Pressure at a given distance from the equipment. That is a more useful number because that is what humans will hear.

³ Based only on distance factor; other factors may change this value such as:

- Unit location (reflective surfaces adjacent to the unit)
- Barrier shielding sources
- Sound path/elevation
- Outside noise sources



Comfort-Cire®

ACCESSORIES

Description	Where Used	Kit Number	Purpose
Liquid Line Solenoid	All models	60M52	Prevents liquid migration to the compressor especially for high liquid riser applications
Hard Start	18	10J42	Scroll compressors usually do not require hard start; maybe needed for utility brown-out or low voltage areas
	24 thru 60	88M91	
Crankcase Heater	18, 24, 30, 36	93M04	Prevents liquid migration to compressor in cold weather
	42	93M05	
	48, 60	Factory Installed	
Compressor Short Cycle Protector	All models	47J27	Delays compressor start 5-7 minutes to prevent short cycling
Low ambient (cooling operation)	All models	34M72	Enables cooling demand down to 30 °F. Will require freeze stat, CC heater and TXV
Loss of Charge Kit	All models	84M23	Protects the compressor if refrigerant charge is too low
Sound Cover	18, 24, 30, 36	14W00	Lowers compressor sound level
	42, 48, 60	14W01	
Additional System Accessories (indoor section)			
TXV Kit	18, 24, 30	H4TXV01	TXVs provide superior refrigerant flow control, comfort and efficiency compared to pistons
	36, 42, 48	H4TXV02	
	60	H4TXV03	
Outdoor Thermostat - Electric Heat	All models	10Z23	Prevents electric heat operation above specific ambient conditions
Outdoor Thermostat - Mounting Box	All models	31461	Mounting box for outdoor thermostat
Freezestat	All models	93G35	Protects the compressor at low suction pressure conditions
Overflow Switch	All models	11U75	Turn the system off, if condensate water overflows due to clogged drain pipes
Blower Time Delay	All models	58M81	Improves system efficiency and comfort
Single Point Power Supply	All models	21H39	Provide single power source in one junction box
Auxiliary Blower Relay	All models	85W66	Maybe required to select multiple indoor blower speeds

Due to ongoing product improvements, specifications and dimensions are subject to change and correction without notice or incurring obligations. Determining the application and suitability for use of any product is the responsibility of the installer. Additionally, the installer is responsible for verifying dimensional data on the actual product prior to beginning any installation preparations. Third party incentive and rebate programs have precise requirements as to product performance and certification. All products meet applicable regulations in effect on date of manufacture; however, certifications are not necessarily granted for the life of a product. Therefore, it is the responsibility of the applicant to determine whether a specific model qualifies for these incentive/rebate programs.

“This product complies with all California product labeling laws including, but not limited to, the Safe Drinking Water and Toxic Enforcement Act of 1986, more commonly known as Proposition 65.”