

TGRG-R

SPECIFICATIONS

Refrigerant System

- Environmentally friendly R410A refrigerant
- Copper tubing with enhanced fin coils
- Internal service gauge ports
- Sleeved distributor tubes
- Antimicrobial insulated drain pan
- High and Low Threaded pressure switches for system protection

Heat Exchanger

- Aluminized Tri-Dimple tubular heat exchanger for increased efficiency
- Pest protected flue outlet

Cabinet Construction

- Heavy-gauge galvanized steel base rails with rigging holes
- Rounded corners for safety and an attractive, clean appearance
- One piece base design for strength and stability
- Condensate and coil runoff drains to the perimeter of the unit
- Horizontal and downflow duct openings are flanged to minimize water entry
- Low profile, with compact footprint
- Insulation to minimize heat loss plus reduce sound
- Textured pre-painted steel cabinet finish
- Superior service access to components
- Louvered coil guard protection
- One piece “no leak” top design

Blower

- Insulated compartment to reduce sound
- Efficient constant torque motor for wide airflow range
- Slide out blower housing for easy service

Controls

- Solid state integrated blower control board with L.E.D. self diagnostics
- Direct spark ignition
- Color coded wiring for easy service

Installation

- Horizontal or down discharge capable
- Horizontal and downflow duct covers provided with unit for installation flexibility
- Drain pan float switch monitors condensate level in drain pan and shuts down unit if drain becomes clogged
- Utility connections on “right side”
- Kits enable bottom gas and power entry through base pan
- Seismic Certification (with Seismic Strapping Kit applied): Latest Edition of International Building Code, California Building Code, and ASCE 7-16

Accessories

- Clip roof curbs and adjustable pitch roof curbs available
- Electric strip heat with optional single point power entry (side entry only)
- Internal Filter kits
- Duct Adapters
- Closure kit for base rail openings

GAS ELECTRIC PACKAGED UNIT

14 SEER



California Only

This product is not certified to be sold or installed in the South Coast Air Quality Management District (SCAQMD). It does not meet the SCAQMD Rule 1111 NOx emission limit of 14 Ng/J.

This product is not certified to be sold or installed in the San Joaquin Valley Air Pollution Control District (SJVAPCD). It does not meet the SJVAPCD Rule 4905 NOx emission limit of 14 Ng/J.

For packaged units that meet SCAQMD/SJVAPCD requirements, refer to the PRPGN14 technical specification.

MODEL NUMBER GUIDE

T	G	R	G	24	54	1	R
Package Unit	Gas/Electric	Residential	'Green' Gas R-410A	Nominal Cooling Capacity BTUH x 1000	BTUH x 1000	Power 208/230-1-60	Series/Revision

ELECTRICAL AND PHYSICAL DATA

Model	Voltage	Phase	Hz	Min Volts @ 60 Hz	MCA	Max Fuse/HACR Breaker	Compressor		Condenser Motor		Blower Motor		Refrig. Charge (oz.)	Weight (lbs.)							
							RLA	LRA	FLA	HP	FLA	HP									
TGRG24541R	208-230	1	60	197	14.4	20	8.5	43.5	1.0	1/6	2.8	1/3	76	388							
TGRG24721R														394							
TGRG30541R														18.2	25	10.5	47	4.1	1/2	80	400
TGRG30721R																					406
TGRG36721R																					419
TGRG36901R																					425
TGRG42901R									26.1	35	14.7	113.0	4.1	1/2	81	94	496				
TGRG481081R																	506				
TGRG601081R																	543				
TGRG601261R																	549				
TGRG601081R	29.3	40	17.3	103.0	1.7	1/4	6	3/4	107												
TGRG601081R									543												
TGRG601261R	35.8	50	22.2	127.9	6.3	1.0	135	549													

PERFORMANCE

Model	COOLING				HEATING				Sound dBA
	Rated AHRI Capacity Btuh (SEER2/SEER2)	SEER/ ERR	SEER2/ ERR2	Rated Sensible Capacity Btuh	Input BTUH	Output BTUH	Efficiency AFUE	Temp Rise Range F	
TGRG24541R	22,600/22,600	14.0/11.0	13.4/10.6	17,400/16,900	54,000	43,800	81%	30-60	77
TGRG24721R					72,000	58,400		40-70	
TGRG30541R	28,400/28,400			21,900/21,800	54,000	43,800		30-60	79
TGRG30721R					72,000	58,000		40-70	
TGRG36721R	34,000/33,400			26,100/25,700	72,000	58,000		35-65	78
TGRG36901R					90,000	72,900		40-70	
TGRG42901R	40,000/40,000			30,800/30,800	90,000	72,900		40-70	
TGRG481081R	45,500/44,500			35,000/34,200	108,000	87,500		40-70	
TGRG601081R	57,000/57,500			41,600/41,900	108,000	87,500		40-70	78
TGRG601261R					126,000	102,100		45-75	

*Certified in accordance with Unitary Air Conditioner Certification Program, which is based on AHRI Standard 210/240



Comfort-Cire®

BLOWER PERFORMANCE

Model	Blower Tap	CFM @ext. Static Pressure in in. wc without filter, dry coil									
		0.1	0.2	0.3	0.4	0.5	0.6	0.7	0.8	0.9	1.0
TGRG24	TAP 1	610	560	525	485	430	N/A	N/A	N/A	N/A	N/A
	TAP 2	820	795	760	720	690	650	615	575	540	470
	TAP 3	960	925	885	850	815	780	745	710	675	635
TGRG30	TAP 1	850	820	780	745	710	680	630	590	550	515
	TAP 2	1040	1000	970	935	900	875	845	815	770	735
	TAP 3	1140	1105	1075	1045	1015	1000	965	925	890	825
TGRG36	TAP 1	850	800	750	700	645	600	550	480	435	N/A
	TAP 2	1245	1210	1175	1140	1100	1065	1025	975	920	845
	TAP 3	1390	1355	1320	1285	1250	1205	1165	1125	1050	875
TGRG42	TAP 1	800	720	640	550	475	390	310	N/A	N/A	N/A
	TAP 2	1470	1410	1360	1300	1260	1210	1155	1095	1000	940
	TAP 3	1600	1555	1510	1470	1430	1390	1340	1265	1210	1155
TGRG48	TAP 1	1145	1075	1000	930	850	790	740	670	570	490
	TAP 2	1675	1630	1600	1540	1490	1440	1390	1300	1230	1125
	TAP 3	1775	1735	1700	1660	1605	1555	1515	1455	N/A	N/A
TGRG60	TAP 1	1045	970	895	820	745	665	580	480	N/A	N/A
	TAP 2	1855	1810	1770	1725	1680	1630	1595	1550	N/A	N/A
	TAP 3	1965	1920	1875	1835	1785	1750	1710	1665	1615	1570

COOLING PERFORMANCE - EXTENDED RATINGS

Outdoor Model	Indoor Temp DB/WB °F	Outdoor Temperature - DB °F														
		65°			82° / 67°			95° / 75°			105° / 85°			115° / 95°		
		Btuh	S/T	kW	Btuh	S/T	kW	Btuh	S/T	kW	Btuh	S/T	kW	Btuh	S/T	kW
TGRG24	85 / 72	28,500	0.65	1.35	26,400	0.67	1.66	24,900	0.69	1.88	23,500	0.71	2.08	22,000	0.73	2.27
	80 / 67	26,300	0.70	1.37	24,300	0.72	1.66	22,600	0.75	1.88	21,600	0.77	2.06	20,200	0.79	2.25
	75 / 63	24,500	0.73	1.38	22,700	0.75	1.66	21,400	0.77	1.88	20,200	0.79	2.05	18,900	0.81	2.24
	75 / 57	22,600	.96	1.39	21,000	.99	1.66	20,000	1	1.87	19,000	1	2.04	17,900	1.00	2.22
TGRG30	85 / 72	36,800	0.65	1.84	33,600	0.68	2.19	31,400	0.71	2.46	29,600	0.73	2.67	27,500	0.75	2.88
	80 / 67	33,900	0.71	1.78	30,900	0.74	2.14	28,400	0.77	2.41	27,200	0.79	2.62	25,300	0.82	2.84
	75 / 63	31,600	0.73	1.73	28,800	0.76	2.09	27,000	0.79	2.37	25,400	0.81	2.58	23,600	0.84	2.79
	75 / 57	29,100	.99	1.67	26,900	1	2.04	25,400	1	2.33	24,100	1	2.55	22,700	1	2.77
TGRG36	85 / 72	41,000	0.66	2.06	38,500	0.68	2.48	36,500	0.71	2.81	34,500	0.73	3.11	32,200	0.75	3.47
	80 / 67	37,900	0.72	2.07	35,600	0.74	2.48	34,000	0.77	2.80	31,800	0.79	3.10	29,600	0.81	3.44
	75 / 63	35,300	0.75	2.07	33,200	0.76	2.48	31,400	0.79	2.79	29,600	0.81	3.09	27,600	0.84	3.44
	75 / 57	32,700	1	2.08	30,900	1	2.48	29,500	1	2.78	28,100	1	3.08	26,400	1	3.43
TGRG42	85 / 72	50,300	0.67	2.48	46,700	0.69	3.04	44,200	0.71	3.46	41,600	0.73	3.83	38,600	0.76	4.25
	80 / 67	46,400	0.73	2.50	42,900	0.75	3.05	40,000	0.77	3.46	38,300	0.80	3.83	35,500	0.83	4.25
	75 / 63	43,200	0.75	2.51	40,000	0.77	3.05	38,100	0.80	3.46	35,800	0.82	3.83	33,100	0.85	4.26
	75 / 57	40,300	.99	2.51	37,800	1	3.05	36,000	1	3.45	34,200	1	3.83	32,000	1	4.26
TGRG48	85 / 72	56,000	0.66	2.83	52,300	0.68	3.38	49,000	0.71	3.82	46,400	0.73	4.23	43,600	0.75	4.68
	80 / 67	51,600	0.72	2.84	48,300	0.75	3.37	45,500	0.77	3.80	42,700	0.79	4.21	40,100	0.82	4.66
	75 / 63	48,200	0.75	2.85	45,000	0.77	3.36	42,100	0.80	3.79	39,900	0.81	4.19	37,400	0.84	4.64
	75 / 57	44,600	1	2.85	42,000	1	3.36	39,600	1	3.78	37,700	1	4.19	35,700	1	4.64
TGRG60	85 / 72	71,300	0.64	3.59	66,700	0.66	4.31	62,900	0.67	4.90	59,800	0.69	5.42	56,300	0.71	6.03
	80 / 67	66,100	0.70	3.60	61,800	0.72	4.31	57,000	0.73	4.89	54,300	0.75	5.41	52,000	0.77	6.01
	75 / 63	61,900	0.72	3.61	57,800	0.74	4.30	54,400	0.76	4.88	51,700	0.77	5.40	48,500	0.79	6.00
	75 / 57	57,200	.97	3.61	53,500	1	4.30	50,600	1	4.87	48,300	1	5.38	45,600	1	5.98

Note: Values based on 0.50" w.c. external static pressure

COOLING PERFORMANCE - EXTENDED RATINGS

Outdoor Model	Indoor Temp DB/WB °F	Outdoor Temperature - DB °F														
		65°			82° / 67°			95° / 75°			105° / 85°			115° / 95°		
		Btuh	S/T	kW	Btuh	S/T	kW	Btuh	S/T	kW	Btuh	S/T	kW	Btuh	S/T	kW
TGRG24	85 / 72	28,200	0.65	1.44	26,100	0.67	1.74	24,600	0.69	1.97	23,200	0.70	2.16	21,700	0.72	2.36
	80 / 67	26,000	0.70	1.45	24,100	0.72	1.75	22,600	0.75	1.97	21,300	0.76	2.15	20,000	0.79	2.34
	75 / 63	24,200	0.72	1.47	22,400	0.74	1.75	21,100	0.77	1.96	19,900	0.79	2.14	18,600	0.81	2.32
	75 / 57	22,300	.96	1.47	20,700	.99	1.74	19,700	1	1.95	18,700	1	2.12	17,600	1.00	2.30
TGRG30	85 / 72	36,600	0.65	1.90	33,400	0.67	2.26	31,200	0.71	2.53	29,300	0.72	2.74	27,300	0.75	2.94
	80 / 67	33,700	0.71	1.84	30,700	0.73	2.20	28,400	0.77	2.48	27,000	0.79	2.69	25,100	0.82	2.90
	75 / 63	31,400	0.73	1.79	28,600	0.76	2.15	26,800	0.79	2.43	25,100	0.81	2.64	23,400	0.84	2.86
	75 / 57	28,900	.99	1.73	26,700	1	2.11	25,200	1	2.39	23,900	1	2.61	22,500	1	2.83
TGRG36	85 / 72	40,900	0.66	2.10	38,400	0.68	2.53	36,300	0.70	2.86	34,300	0.72	3.16	32,100	0.75	3.51
	80 / 67	37,700	0.72	2.11	35,400	0.74	2.53	33,500	0.77	2.84	31,600	0.79	3.14	29,500	0.81	3.49
	75 / 63	35,200	0.74	2.12	33,000	0.76	2.52	31,200	0.79	2.83	29,500	0.81	3.14	27,400	0.84	3.48
	75 / 57	32,500	1	2.13	30,800	1	2.52	29,400	1	2.83	27,900	1	3.13	26,300	1	3.48
TGRG42	85 / 72	50,100	0.67	2.57	46,400	0.69	3.12	43,900	0.71	3.55	41,300	0.73	3.91	38,300	0.76	4.33
	80 / 67	46,100	0.73	2.58	42,700	0.75	3.13	40,000	0.77	3.55	38,100	0.79	3.91	35,200	0.83	4.33
	75 / 63	42,900	0.75	2.59	39,700	0.77	3.13	37,800	0.80	3.55	35,500	0.81	3.91	32,900	0.85	4.35
	75 / 57	40,000	.99	2.60	37,500	1	3.13	35,700	1	3.53	33,900	1	3.92	31,800	1	4.34
TGRG48	85 / 72	55,700	0.66	2.93	52,000	0.68	3.47	48,700	0.71	3.92	46,100	0.73	4.33	43,300	0.75	4.77
	80 / 67	51,300	0.72	2.93	47,900	0.74	3.46	44,500	0.77	3.90	42,400	0.79	4.30	39,800	0.82	4.75
	75 / 63	47,900	0.74	2.94	44,700	0.77	3.45	41,800	0.79	3.88	39,600	0.81	4.28	37,000	0.84	4.73
	75 / 57	44,300	1	2.94	41,700	1	3.45	39,300	1	3.87	37,400	1	4.28	35,400	1	4.73
TGRG60	85 / 72	71,100	0.64	3.66	66,500	0.66	4.38	62,700	0.67	4.97	59,500	0.69	5.50	56,000	0.71	6.11
	80 / 67	65,900	0.70	3.68	61,600	0.72	4.38	57,000	0.73	4.96	55,000	0.75	5.48	51,800	0.77	6.08
	75 / 63	61,600	0.72	3.68	57,500	0.74	4.38	54,200	0.75	4.95	51,400	0.77	5.47	48,300	0.79	6.07
	75 / 57	56,900	.97	3.68	53,300	1	4.37	50,300	1	4.94	48,100	1	5.46	45,400	1	6.05

Note: Values based on 0.58" w.c. external static pressure

ACCESSORY AIR RESISTANCE DATA - IN. W.G.

Air Volume cfm	Rectangular to Round Duct Adaptor Kits					
	Downflow		Horizontal			
	14 in. Diameter		14 in. Diameter		16 in. Diameter	18 in. Diameter
	24, 30, 36	42, 48, 60	24, 30, 36	42, 48, 60	42, 48, 60	42, 48, 60
500	0.03	/	0.04	/	/	/
600	0.05	/	0.07	/	/	/
700	0.08	0.13	0.08	0.13	/	/
800	0.10	0.17	0.12	0.16	/	/
900	0.12	0.21	0.15	0.21	/	/
1000	0.17	0.24	0.19	0.25	0.11	0.03
1100	0.18	0.30	0.23	0.30	0.11	0.03
1200	0.20	0.36	0.29	0.37	0.13	0.03
1300	0.26	0.43	0.31	0.43	0.17	0.03
1400	0.31	0.50	0.39	0.51	0.20	0.03
1500	/	0.57	/	0.57	0.21	0.05
1600	/	0.63	/	0.65	0.26	0.05
1700	/	0.71	/	0.72	0.30	0.06
1800	/	0.80	/	0.81	0.30	0.06
1900	/	0.91	/	0.90	0.40	0.06
2000	/	0.99	/	1.01	0.41	0.06

DIMENSIONS (IN.) - 2-3 TON UNITS

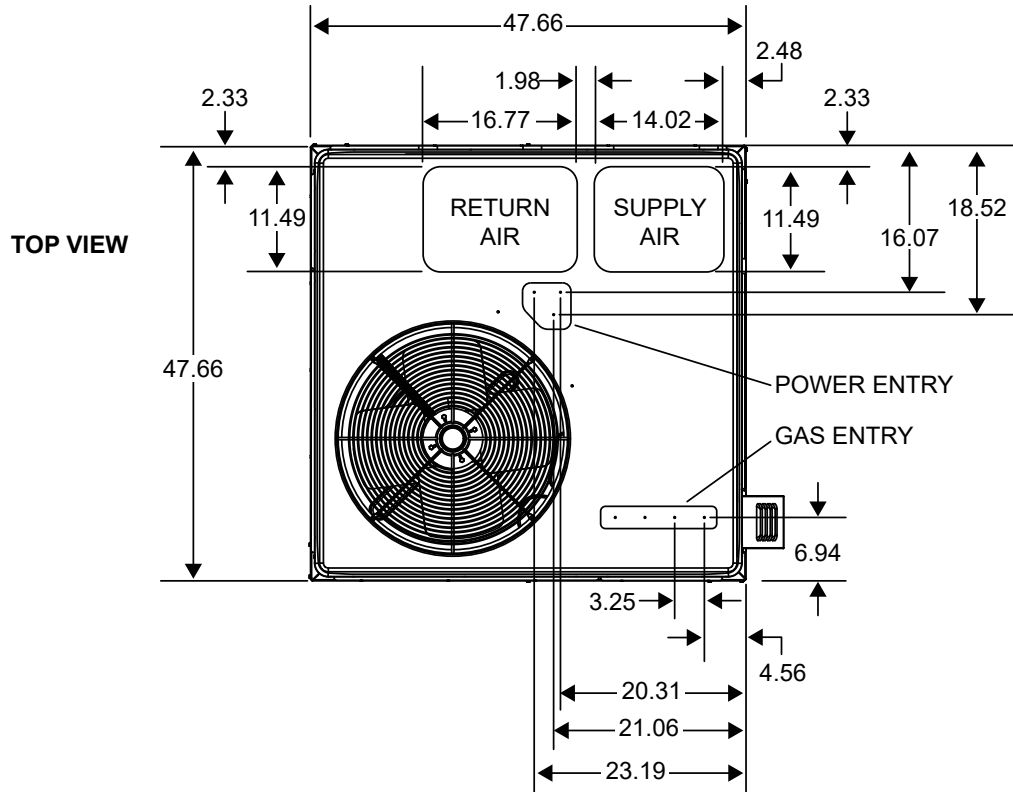

SIDE VIEWS

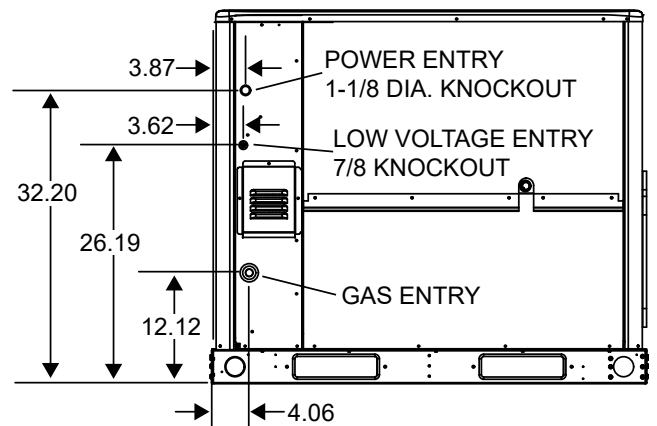
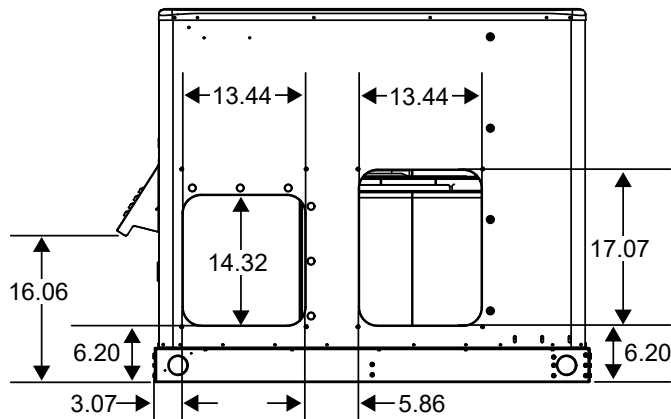
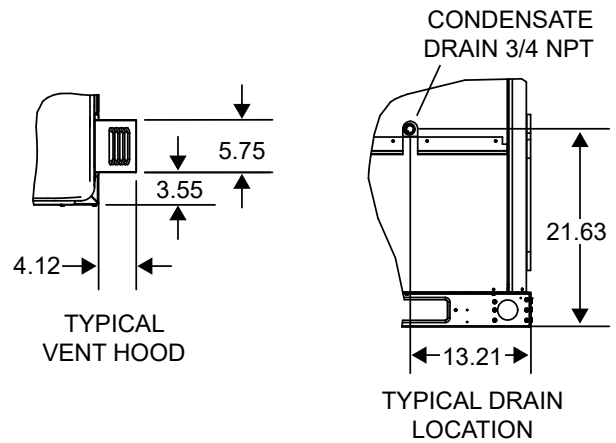
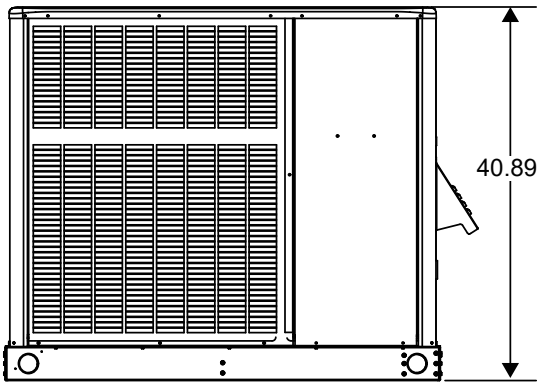

DIMENSIONS (IN.) - 3.5-5 TON UNITS

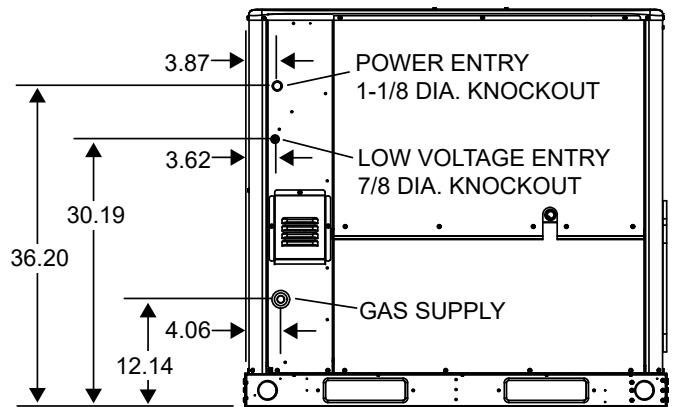
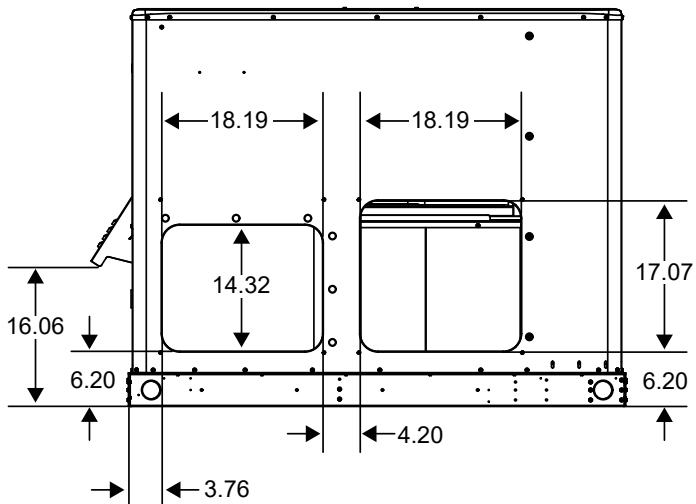
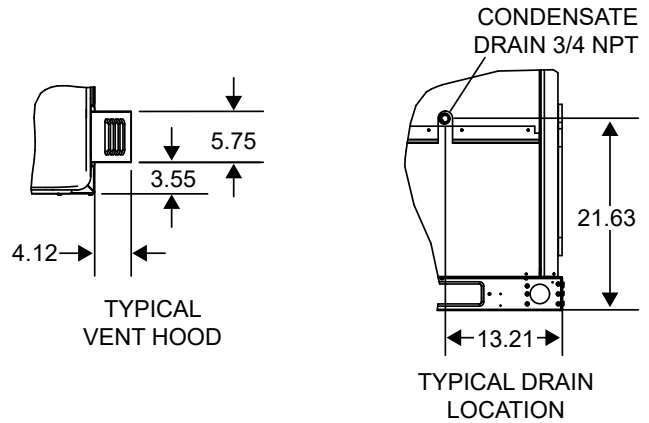
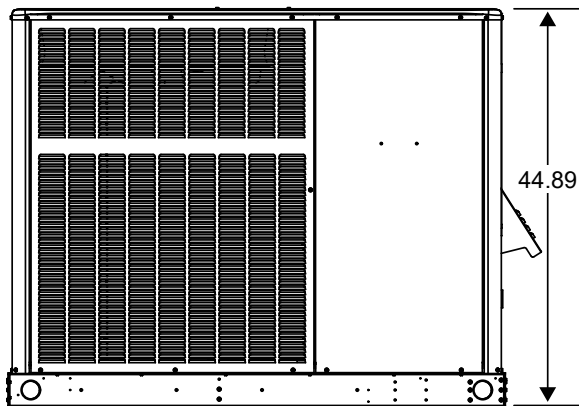
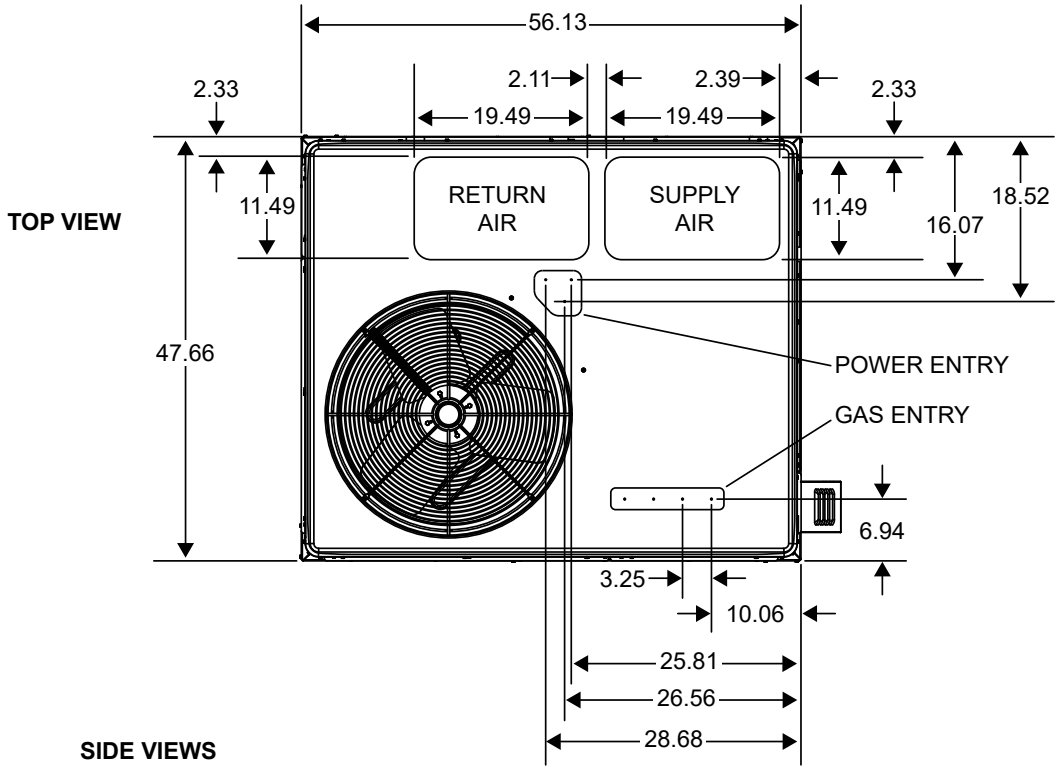

ROOF CURB DIMENSIONS - 2-3 TON UNITS

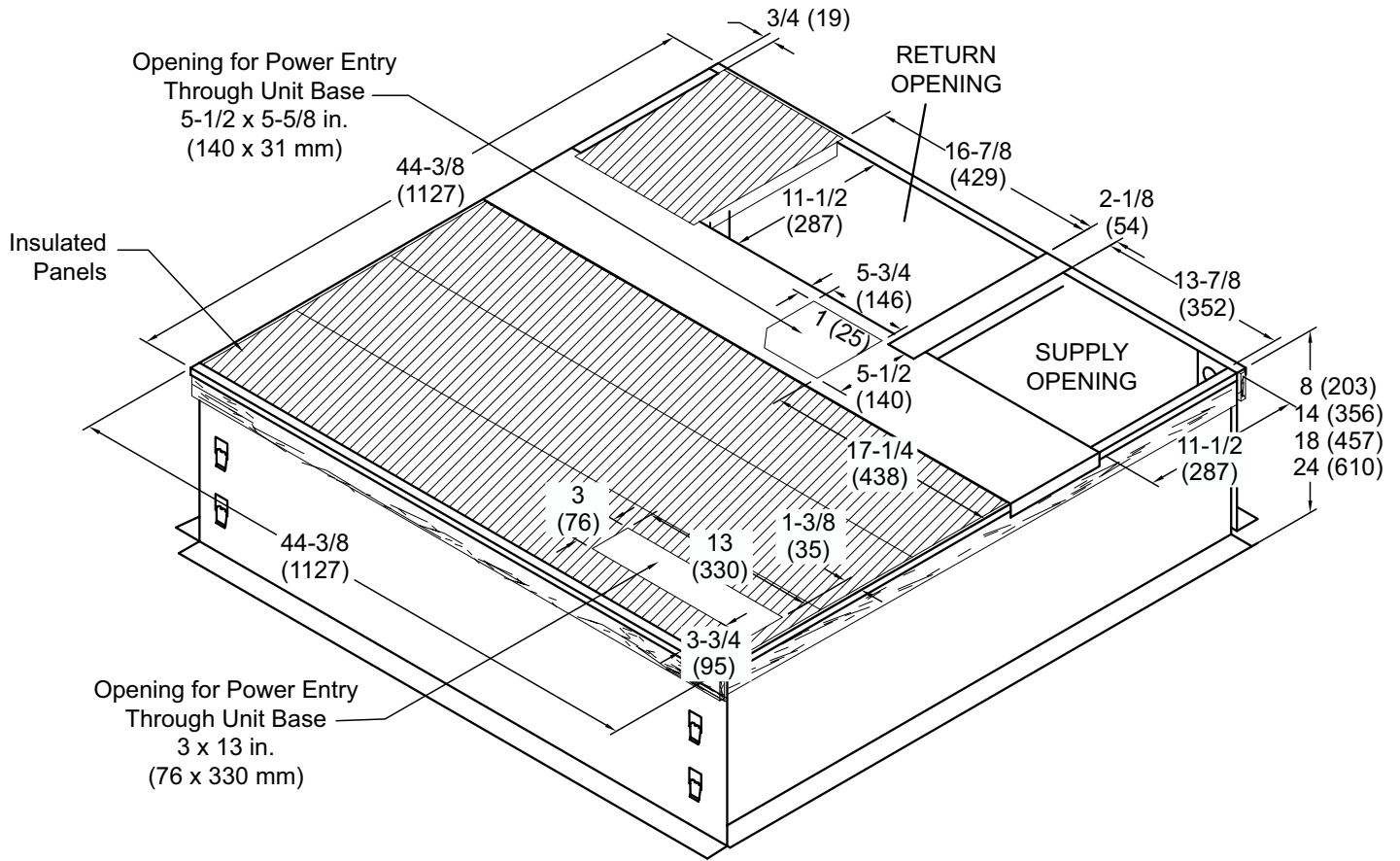

NOTE - If bottom entry is used, condensate from the heat exchanger may leak during warm ambient temperatures in humid climates. Ensure that bottom entry is watertight, if used.

NOTE - Roof deck may be omitted within confines of curb

NOTE - All Curbs:

- IBC 2018 compliant
- CBC 2019 compliant
- Seismic rating - SDS 2.0g z/h=1 I_p=1.5
- Wind rating - 240 mph (Lateral), 214 mph (Uplift)
- Maximum load rating - 800 lbs.
- Tool-less filter access panels NOT for seismic-rated applications

ROOF CURB DIMENSIONS - 3.5-5 TON UNITS

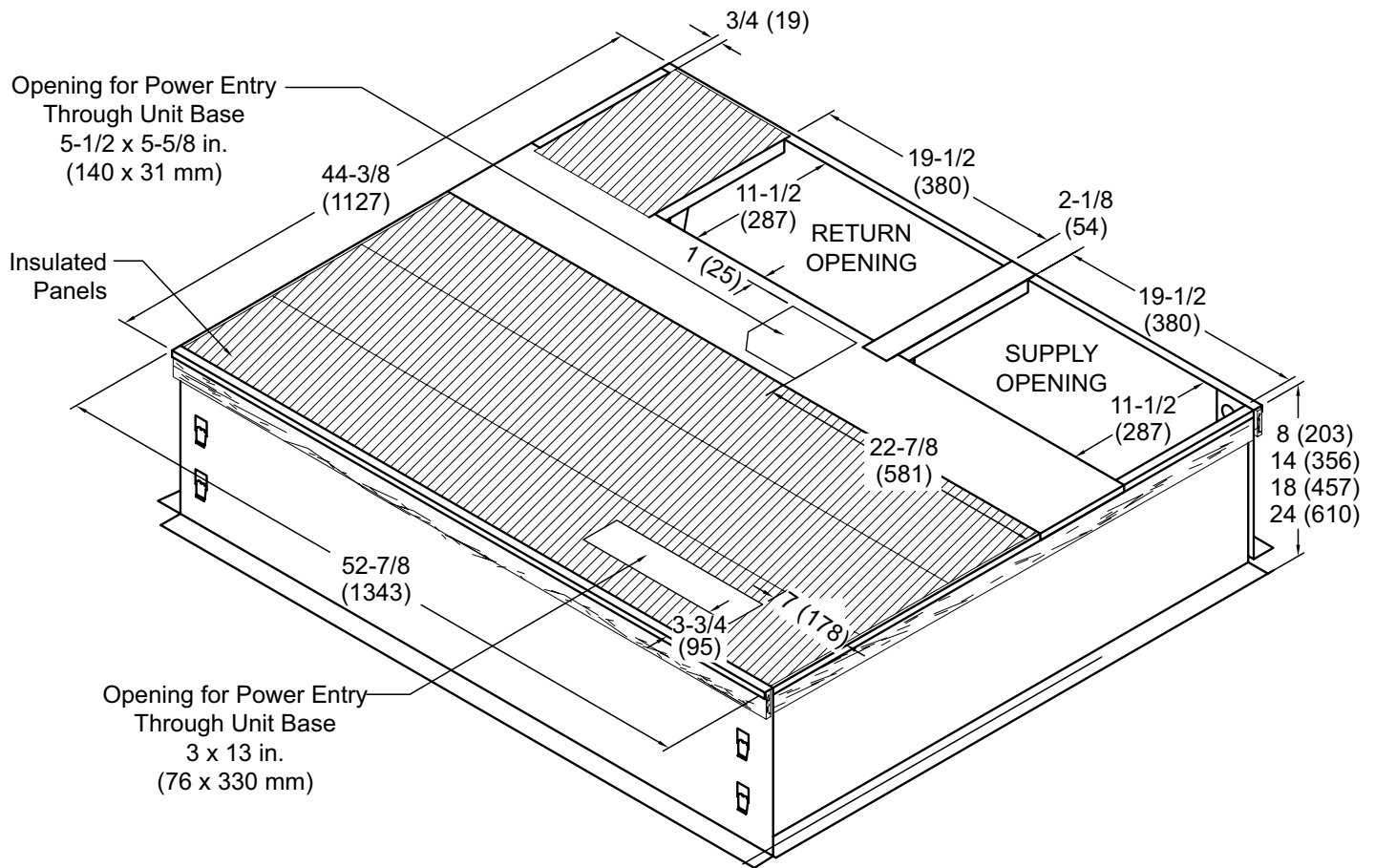

NOTE - If bottom entry is used, condensate from the heat exchanger may leak during warm ambient temperatures in humid climates. Ensure that bottom entry is watertight, if used.

NOTE - Roof deck may be omitted within confines of curb

NOTE - All Curbs:

- IBC 2018 compliant
- CBC 2019 compliant
- Seismic rating - SDS 2.0g z/h=1 Ip=1.5
- Wind rating - 240 mph (Lateral), 214 mph (Uplift)
- Maximum load rating - 800 lbs.
- Tool-less filter access panels NOT for seismic-rated applications

ADJUSTABLE CURB (KNOCK-DOWN STYLE) DIMENSIONS - 2-3 TON UNITS

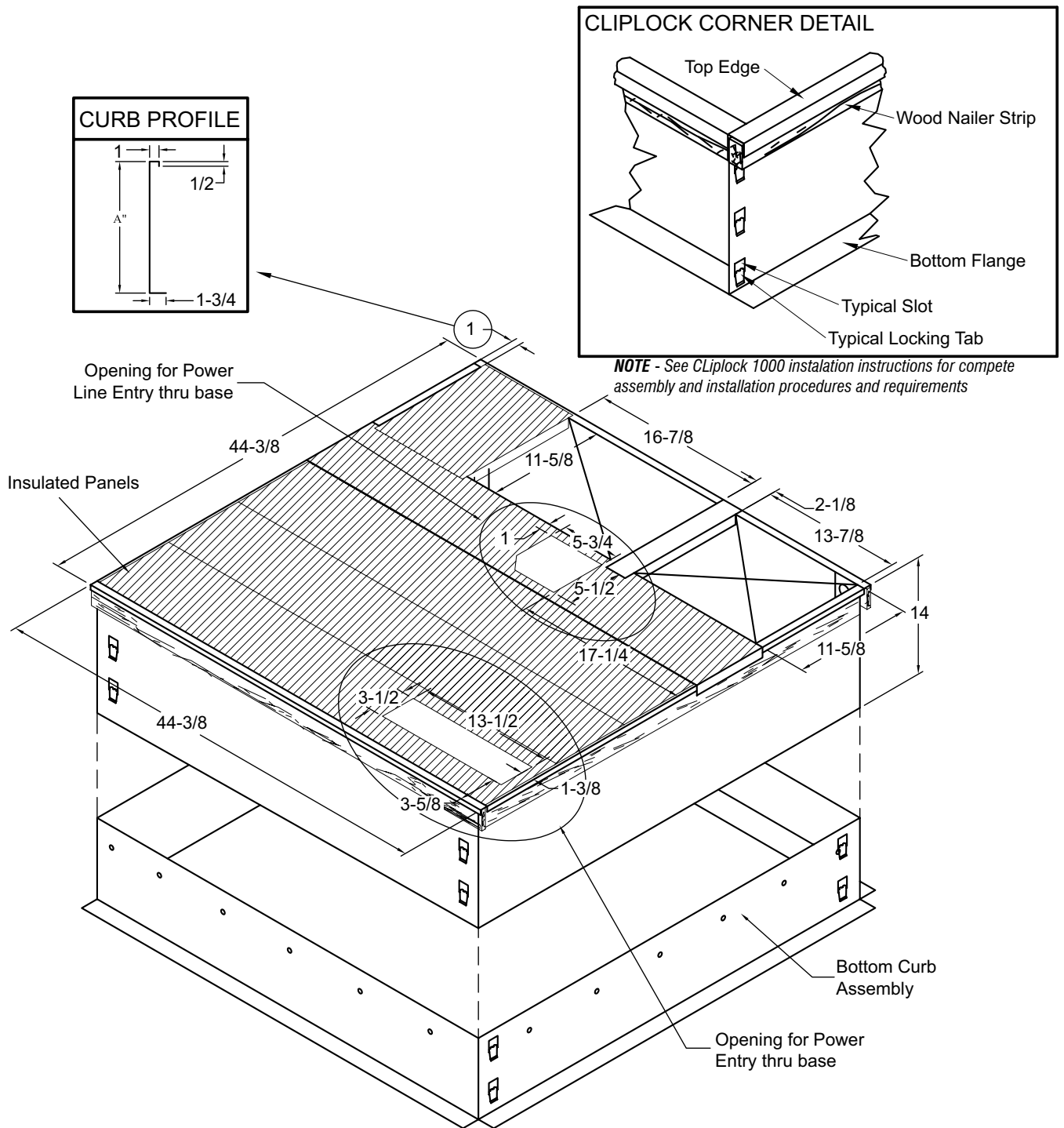

NOTE - If bottom entry is used, condensate from the heat exchanger may leak during warm ambient temperatures in humid climates. Ensure that bottom entry is watertight, if used.

NOTE - Roof deck may be omitted within confines of curb

NOTE - All Curbs:

- IBC 2018 compliant
- CBC 2019 compliant
- Seismic rating - SDS 2.0g z/h=1 Ip=1.5
- Wind rating - 240 mph (Lateral), 214 mph (Uplift)
- Maximum load rating - 800 lbs.
- Tool-less filter access panels NOT for seismic-rated applications

ADJUSTABLE CURB (KNOCK-DOWN STYLE) DIMENSIONS - 3.5-5 TON UNITS

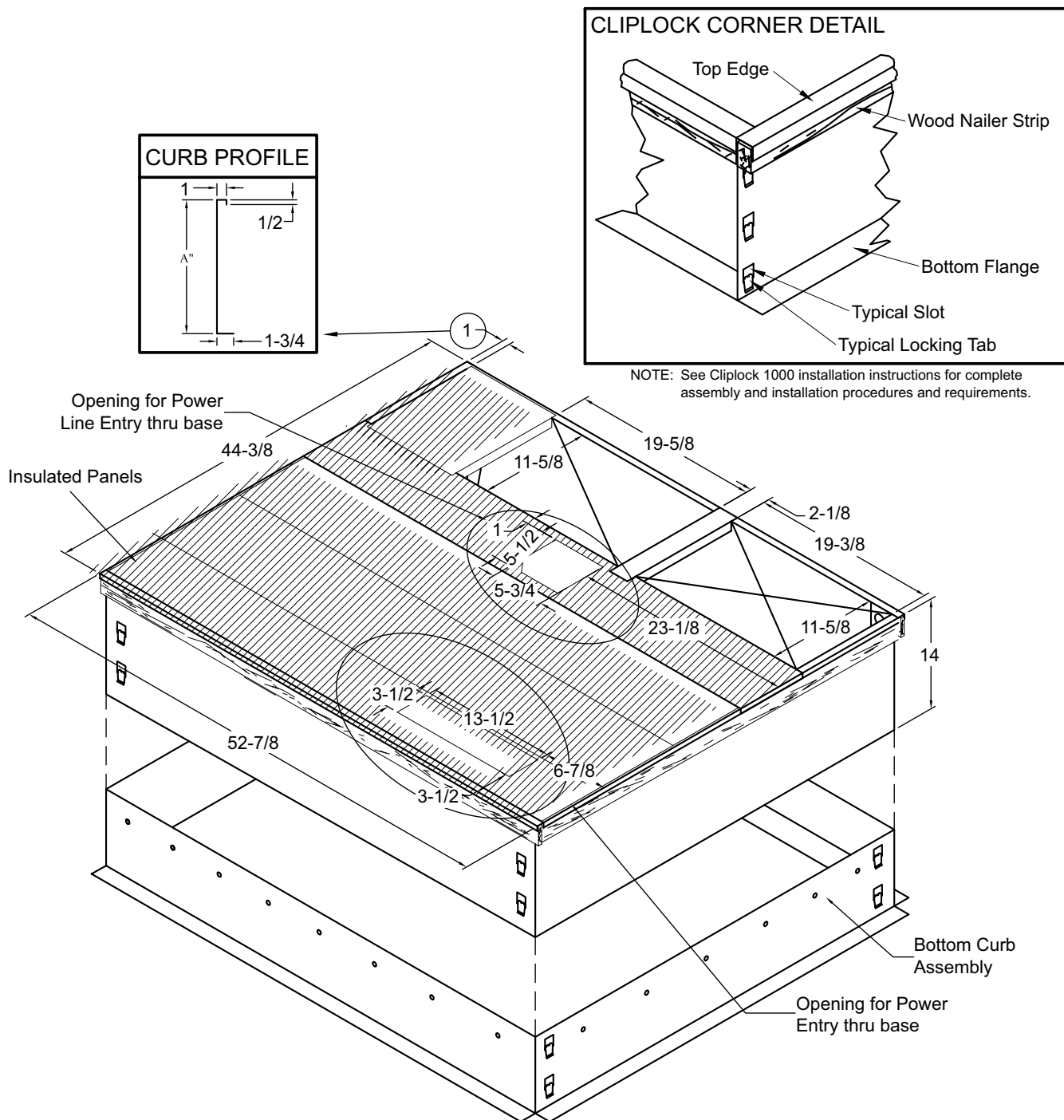

NOTE - If bottom entry is used, condensate from the heat exchanger may leak during warm ambient temperatures in humid climates. Ensure that bottom entry is watertight, if used.

NOTE - Roof deck may be omitted within confines of curb

NOTE - All Curbs:

- IBC 2018 compliant
- CBC 2019 compliant
- Seismic rating - SDS 2.0g z/h = 1 I_p = 1.5
- Wind rating - 240 mph (Lateral), 214 mph (Uplift)
- Maximum load rating - 800 lbs.
- Tool-less fliter access panels NOT for seismic-rated applications

ADJUSTABLE CURB (WELDED STYLE) DIMENSIONS

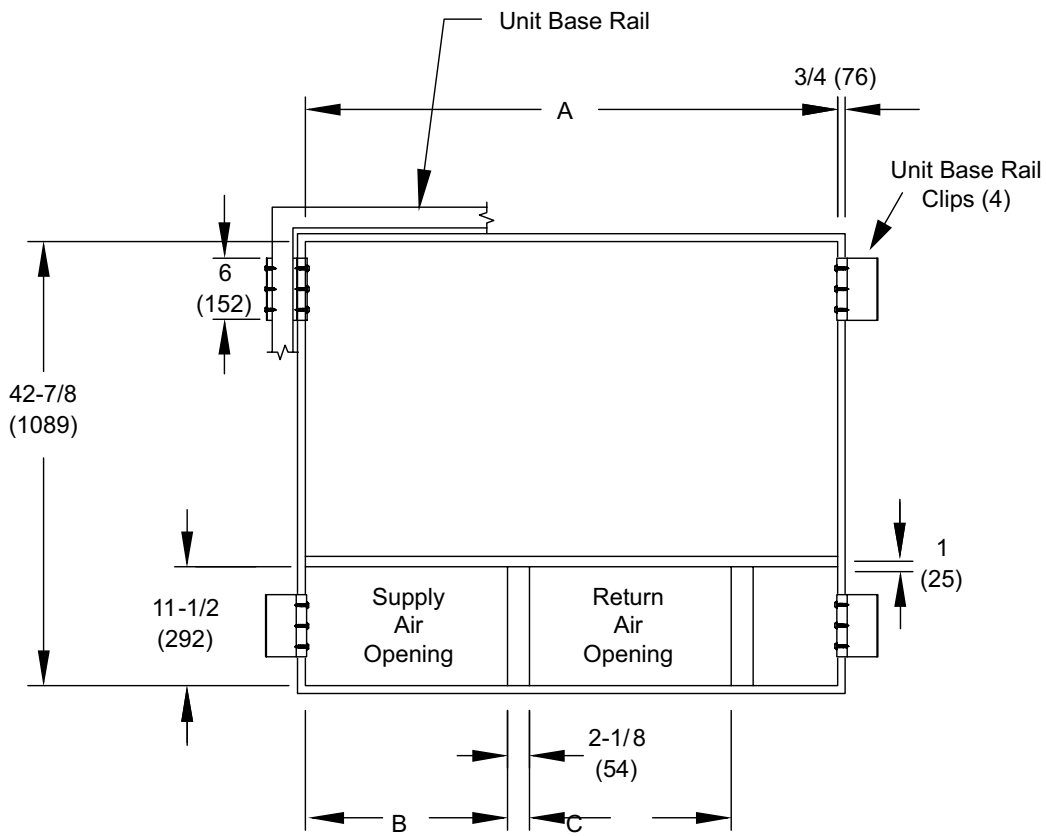
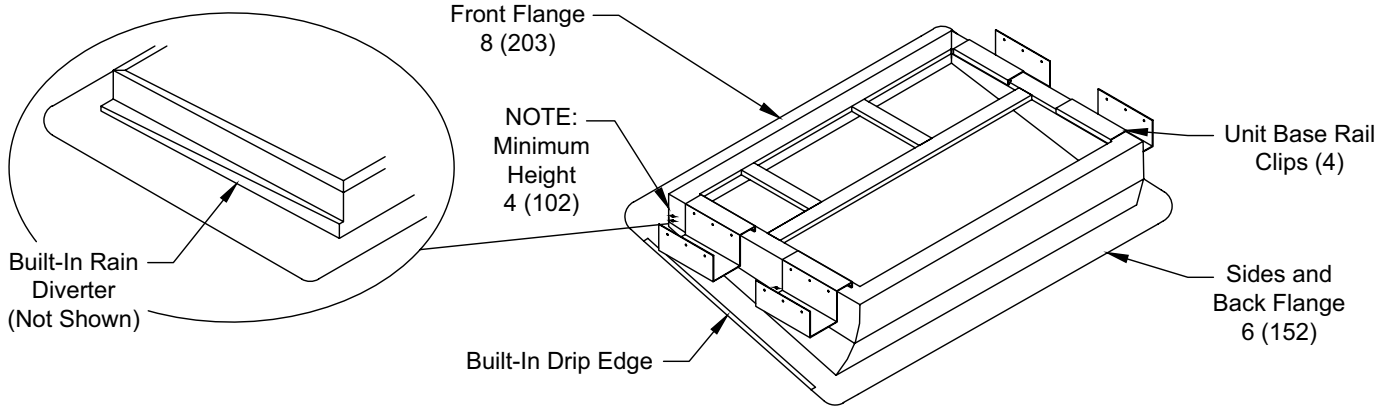

Usage	A		B		C	
	in.	mm.	in.	mm.	in.	mm.
24,30,36	42-7/8	1089	13-7/8	352	16-7/8	429
42,46,60	51-3/8	1305	19-1/2	495	19-1/2	495

ACCESSORY LIST

Description	Where Used	Kit Number
Compressor Crankcase Heater	36, 42, 48, 60	11X27
Compressor Hard Start Kit	24,30,36	10J42
	42, 48, 60	88M91
Compressor Timed-Off Control	All	47J28
Low Ambient Kit	All	21D20
Internal Filter Rack Kit	24,30,36	11U73
	42, 48, 60	11U74
LPG/Propane Conversion Kit (Ser#1621B16144 or Lower)	All	21V12+ 22B87
LPG/Propane Conversion Kit (Ser#1621B16145 or Higher)	All	22B87
8" Height Full Perimeter Curb	24, 30, 36	21J13
	42, 48, 60	21J17
14" Height Full Perimeter Curb	24, 30, 36	21J14
	42, 48, 60	21J19
18" Height Full Perimeter Curb	24, 30, 36	21J15
	42, 48, 60	21J20
24" Height Full Perimeter Curb	24, 30, 36	21J16
	42, 48, 60	21J25
Adjustable Pitch Roof Curb (Knock-Down Style)	24, 30, 36	21J26
	42, 48, 60	21U04
Adjustable Pitch Roof Curb (Welded Style)	24, 30, 36	22V54
	42, 48, 60	22V55
Strapping Kit - Hurricane	Slab	21J74
	Rail	22G53
Strapping Kit - Seismic	All	21J75
Duct Adapter Kit - Horizontal	14 in. dia.	24, 30, 36
	14 in. dia.	42, 48, 60
	16 in. dia.	42, 48, 60
	18 in. dia.	42, 48, 60
Duct Adapter Kit - Downflow	14 in. dia.	24, 30, 36
	14 in. dia.	42, 48, 60
Bottom Power Entry Kit	All	21J78
Bottom Gas Entry Kit	All	21D34
Base Rail Openings - Closure Kit	All	21J84

"This product complies with all California product labeling laws including, but not limited to, the Safe Drinking Water and Toxic Enforcement Act of 1986, more commonly known as Proposition 65."

Due to ongoing product improvements, specifications and dimensions are subject to change and correction without notice or incurring obligations. Determining the application and suitability for use of any product is the responsibility of the installer. Additionally, the installer is responsible for verifying dimensional data on the actual product prior to beginning any installation preparations. Third party incentive and rebate programs have precise requirements as to product performance and certification. All products meet applicable regulations in effect on date of manufacture; however, certifications are not necessarily granted for the life of a product. Therefore, it is the responsibility of the applicant to determine whether a specific model qualifies for these incentive/rebate programs.