

## SPECIFICATIONS

### Refrigerant System

- Environmentally friendly R410A refrigerant
- Copper tubing with enhanced fin coils
- Internal service gauge ports
- Sleeved distributor tubes
- Antimicrobial insulated drain pan
- High and Low Threaded pressure switches for system protection

### Heat Exchanger

- RX models comply with California Energy Commission Ultra Low NOx regulations (<14 ng/J)
- Stainless steel dimpled tubular heat exchanger for increased efficiency
- Pest protected flue outlet

### Cabinet Construction

- Heavy-gauge galvanized steel base rails with rigging holes
- Rounded corners for safety and an attractive, clean appearance
- One piece base design for strength and stability
- Condensate and coil runoff drains to the perimeter of the unit
- Horizontal and downflow duct openings are flanged to minimize water entry
- Low profile, with compact footprint
- Insulation to minimize heat loss plus reduce sound
- Textured pre-painted steel cabinet finish
- Superior service access to components
- Louvered coil guard protection
- One piece "no leak" top design

### Blower

- Insulated compartment to reduce sound
- Efficient constant torque motor for wide airflow range
- Slide out blower housing for easy service

### Controls

- Solid state integrated blower control board with L.E.D. self diagnostics
- Direct spark ignition
- Color coded wiring for easy service

### Installation

- Horizontal or down discharge capable
- Horizontal and downflow duct covers provided with unit for installation flexibility
- Drain pan float switch monitors condensate level in drain pan and shuts down unit if drain becomes clogged
- Utility connections on "right side"
- Kits enable bottom gas and power entry through base pan
- Seismic Certification (with Seismic Strapping Kit applied): Latest Edition of International Building Code, California Building Code, and ASCE 7-16

### Accessories

- Clip roof curbs and adjustable pitch roof curbs available
- Internal Filter kits
- Duct Adapters
- Closure kit for base rail openings

## GAS ELECTRIC PACKAGED UNIT - ULTRA LOW NOx

14 SEER



*This furnace meets the South Coast Air Quality Management District (SCAQMD) Rule 1111 and San Joaquin Valley Air Pollution Control District (SJVAPCD) Rule 4905 NOx emission limit (14 ng/J) and can be installed within the SCAQMD or SJVAPCD and Bay Area.*

## MODEL NUMBER GUIDE

<b>T</b>	<b>G</b>	<b>R</b>	<b>X</b>	<b>24</b>	<b>54</b>	<b>1</b>	<b>R</b>
Package Unit	Gas/Electric	Residential	Constant Torque Motor Low NOx	Nominal Cooling Capacity BTUH x 1000	BTUH x 1000	Power 208/230-1-60	Series/Revision

## ELECTRICAL AND PHYSICAL DATA

Model	Voltage	Phase	Hz	Min Volts @ 60 Hz	MCA	Max Fuse/HACR Breaker	Compressor		Condenser Motor		Blower Motor		Refrig. Charge (oz.)	Weight (lbs.)
							RLA	LRA	FLA	HP	FLA	HP		
TGRX24541R	208-230	1	60	197	14.4	20	8.5	43.5	1.0	1/6	2.8	1/3	76	407
TGRX36541R					22.7	30	14.1	72.2			4.1	1/2	81	430
TGRX42721R					26.1	35	14.7	113.0	1.7	1/4	6.0	3/4	94	522
TGRX48721R					29.3	40	17.3	103.0			6.0	3/4	107	525
TGRX60721R					35.8	50	22.2	127.9			6.3	1.0	135	557

## PERFORMANCE

Model	COOLING				HEATING				Sound dBA
	Rated AHRI Capacity Btuh (SEER / SEER2)	Efficiency		Rated Sensible Capacity Btuh (SEER / SEER2)	Input BTUH	Output BTUH	Efficiency AFUE	Temp Rise Range °F	
		SEER / EER	SEER2 / EER2						
TGRX24541R	22,600 / 22,600	14.0 / 11.0	13.4 / 10.6	17,400 / 16,900	54,000	43,800	81%	30-60	77
TGRX36541R	34,000 / 33,400			26,100 / 25,700	54,000	43,800		30-60	78
TGRX42721R	40,000 / 40,000			30,800 / 30,800	72,000	58,400		25-55	78
TGRX48721R	45,500 / 44,500			35,000 / 34,200	72,000	58,400		25-55	77
TGRX60721R	57,000 / 57,500			41,600 / 41,900	72,000	58,400		25-55	78

\*Certified in accordance with Unitary Air Conditioner Certification Program, which is based on AHRI Standard 210/240



Comfort-Cire®

## BLOWER PERFORMANCE

Model	Blower Tap		SCFM @ External Static Pressure (in w.c.) - No filter, Dry Coil						
			0.1	0.2	0.3	0.4	0.5	0.6	
TGRX24541R	Tap 1	Fan Only	640	590	545	495	445	385	
	Tap 2	Cooling (Low Static)	820	785	750	715	675	635	
	Tap 3	Cooling (High Static)	960	925	885	850	815	780	
	Tap 4	Heating (Low Static)	SCFM	925	890	865	830	795	765
			Rise	44	46	47	49	51	53
Tap 5	Heating (High Static)	SCFM	1005	970	940	910	880	855	
		Rise	41	42	43	45	46	48	
TGRX36541R	Tap 1	Fan Only	795	745	700	645	590	525	
	Tap 2	Cooling (Low Static)	1250	1215	1180	1145	1115	1085	
	Tap 3	Cooling (High Static)	1390	1355	1320	1285	1250	1205	
	Tap 4	Heating (Low Static)	SCFM	935	890	855	815	770	725
			Rise	44	46	48	50	53	56
Tap 5	Heating (High Static)	SCFM	1050	1010	970	935	895	860	
		Rise	39	40	42	44	46	47	
TGRX42721R	Tap 1	Fan Only	775	700	615	535	470	390	
	Tap 2	Cooling (Low Static)	1460	1420	1380	1340	1300	1255	
	Tap 3	Cooling (High Static)	1600	1555	1510	1470	1430	1390	
	Tap 4	Heating (Low Static)	SCFM	1410	1370	1325	1285	1240	1200
			Rise	39	40	41	42	44	45
Tap 5	Heating (High Static)	SCFM	1535	1495	1555	1415	1375	1335	
		Rise	35	36	37	38	39	41	
TGRX48721R	Tap 1	Fan Only	1065	1020	965	910	850	790	
	Tap 2	Cooling (Low Static)	1665	1630	1595	1560	1530	1490	
	Tap 3	Cooling (High Static)	1775	1735	1700	1660	1605	1555	
	Tap 4	Heating (Low Static)	SCFM	1405	1370	1325	1290	1245	1205
			Rise	39	40	41	42	44	45
Tap 5	Heating (High Static)	SCFM	1515	1480	1440	1405	1370	1325	
		Rise	36	37	38	39	40	41	
TGRX60721R	Tap 1	Fan Only	1240	1190	1125	1060	995	940	
	Tap 2	Cooling (Low Static)	1885	1840	1800	1755	1715	1675	
	Tap 3	Cooling (High Static)	1965	1920	1875	1835	1785	1750	
	Tap 4	Heating (Low Static)	SCFM	1420	1365	1315	1265	1215	1155
			Rise	38	40	41	43	45	47
Tap 5	Heating (High Static)	SCFM	1570	1520	1470	1420	1370	1320	
		Rise	35	36	37	38	40	41	

## COOLING PERFORMANCE - EXTENDED RATINGS

Outdoor Model	Indoor Temp DB/WB °F	Outdoor Temperature - DB °F														
		65°			82° / 67°			95° / 75°			105° / 85°			115° / 95°		
		Btuh	S/T	kW	Btuh	S/T	kW	Btuh	S/T	kW	Btuh	S/T	kW	Btuh	S/T	kW
TGRX24541R	85 / 72	28,500	0.65	1.35	26,400	0.67	1.66	24,900	0.69	1.88	23,500	0.71	2.08	22,000	0.73	2.27
	80 / 67	26,300	0.70	1.37	24,300	0.72	1.66	22,600	0.75	1.88	21,600	0.77	2.06	20,200	0.79	2.25
	75 / 63	24,500	0.73	1.38	22,700	0.75	1.66	21,400	0.77	1.88	20,200	0.79	2.05	18,900	0.81	2.24
	75 / 57	22,600	0.96	1.39	21,000	0.99	1.66	20,000	1.00	1.87	19,000	1.00	2.04	17,900	1.00	2.22
TGRX36541R	85 / 72	41,000	0.66	2.06	38,500	0.68	2.48	36,500	0.71	2.81	34,500	0.73	3.11	32,200	0.75	3.47
	80 / 67	37,900	0.72	2.07	35,600	0.74	2.48	34,000	0.77	2.80	31,800	0.79	3.10	29,600	0.81	3.44
	75 / 63	35,300	0.75	2.07	33,200	0.76	2.48	31,400	0.79	2.79	29,600	0.81	3.09	27,600	0.84	3.44
	75 / 57	32,700	1.00	2.08	30,900	1.00	2.48	29,500	1.00	2.78	28,100	1.00	3.08	26,400	1.00	3.43
TGRX42721R	85 / 72	50,300	0.67	2.48	46,700	0.69	3.04	44,200	0.71	3.46	41,600	0.73	3.83	38,600	0.76	4.25
	80 / 67	46,400	0.73	2.50	42,900	0.75	3.05	40,000	0.77	3.46	38,300	0.80	3.83	35,500	0.83	4.25
	75 / 63	43,200	0.75	2.51	40,000	0.77	3.05	38,100	0.80	3.46	35,800	0.82	3.83	33,100	0.85	4.26
	75 / 57	40,300	0.99	2.51	37,800	1.00	3.05	36,000	1.00	3.45	34,200	1.00	3.83	32,000	1.00	4.26
TGRX48721R	85 / 72	56,000	0.66	2.83	52,300	0.68	3.38	49,000	0.71	3.82	46,400	0.73	4.23	43,600	0.75	4.68
	80 / 67	51,600	0.72	2.84	48,300	0.75	3.37	45,500	0.77	3.80	42,700	0.79	4.21	40,100	0.82	4.66
	75 / 63	48,200	0.75	2.85	45,000	0.77	3.36	42,100	0.80	3.79	39,900	0.81	4.19	37,400	0.84	4.64
	75 / 57	44,600	1.00	2.85	42,000	1.00	3.36	39,600	1.00	3.78	37,700	1.00	4.19	35,700	1.00	4.64
TGRX60721R	85 / 72	71,300	0.64	3.59	66,700	0.66	4.31	62,900	0.67	4.90	59,800	0.69	5.42	56,300	0.71	6.03
	80 / 67	66,100	0.70	3.60	61,800	0.72	4.31	57,000	0.73	4.89	55,300	0.75	5.41	52,000	0.77	6.01
	75 / 63	61,900	0.72	3.61	57,800	0.74	4.30	54,400	0.76	4.88	51,700	0.77	5.40	48,500	0.79	6.00
	75 / 57	57,200	0.97	3.61	53,500	1.00	4.30	50,600	1.00	4.87	48,300	1.00	5.38	45,600	1.00	5.98

NOTE: Values based on 0.50" w.c. external static pressure

## COOLING PERFORMANCE - EXTENDED RATINGS

Outdoor Model	Indoor Temp DB/WB °F	Outdoor Temperature - DB °F														
		65°			82° / 67°			95° / 75°			105° / 85°			115° / 95°		
		Btuh	S/T	kW	Btuh	S/T	kW	Btuh	S/T	kW	Btuh	S/T	kW	Btuh	S/T	kW
TGRX24541R	85 / 72	28,200	0.65	1.44	26,100	0.67	1.74	24,600	0.69	1.97	23,200	0.70	2.16	21,700	0.72	2.36
	80 / 67	26,000	0.70	1.45	24,100	0.72	1.75	22,600	0.75	1.97	21,300	0.76	2.15	20,000	0.79	2.34
	75 / 63	24,200	0.72	1.47	22,400	0.74	1.75	21,100	0.77	1.96	19,900	0.79	2.14	18,600	0.81	2.32
	75 / 57	22,300	0.96	1.47	20,700	0.99	1.74	19,700	1.00	1.95	18,700	1.00	2.12	17,600	1.00	2.30
TGRX36541R	85 / 72	40,900	0.66	2.10	38,400	0.68	2.53	36,300	0.70	2.86	34,300	0.72	3.16	32,100	0.75	3.51
	80 / 67	37,700	0.72	2.11	35,400	0.74	2.53	33,500	0.77	2.84	31,600	0.79	3.14	29,500	0.81	3.49
	75 / 63	35,200	0.74	2.12	33,000	0.76	2.52	31,200	0.79	2.83	29,500	0.81	3.14	27,400	0.84	3.48
	75 / 57	32,500	1.00	2.13	30,800	1.00	2.52	29,400	1.00	2.83	27,900	1.00	3.13	26,300	1.00	3.48
TGRX42721R	85 / 72	50,100	0.67	2.57	46,400	0.69	3.12	43,900	0.71	3.55	41,300	0.73	3.91	38,300	0.76	4.33
	80 / 67	46,100	0.73	2.58	42,700	0.75	3.13	40,000	0.77	3.55	38,100	0.80	3.91	35,200	0.83	4.33
	75 / 63	42,900	0.75	2.59	39,700	0.77	3.13	37,800	0.80	3.55	35,500	0.82	3.91	32,900	0.85	4.35
	75 / 57	40,000	0.99	2.60	37,500	1.00	3.13	35,700	1.00	3.53	33,900	1.00	3.92	31,800	1.00	4.34
TGRX48721R	85 / 72	55,700	0.66	2.93	52,000	0.68	3.47	48,700	0.71	3.92	46,100	0.73	4.33	43,300	0.75	4.77
	80 / 67	51,300	0.72	2.93	47,900	0.74	3.46	44,500	0.77	3.90	42,400	0.79	4.30	39,800	0.82	4.75
	75 / 63	47,900	0.74	2.94	44,700	0.77	3.45	41,800	0.79	3.88	39,600	0.81	4.28	37,000	0.84	4.73
	75 / 57	44,300	1.00	2.94	41,700	1.00	3.45	39,300	1.00	3.87	37,400	1.00	4.28	35,400	1.00	4.73
TGRX60721R	85 / 72	71,100	0.64	3.66	66,500	0.66	4.38	62,700	0.67	4.97	59,500	0.69	5.50	56,000	0.71	6.11
	80 / 67	65,900	0.70	3.68	61,600	0.72	4.38	57,000	0.73	4.96	55,000	0.75	5.48	51,800	0.77	6.08
	75 / 63	61,600	0.72	3.68	57,500	0.74	4.38	54,200	0.75	4.95	51,400	0.77	5.47	48,300	0.79	6.07
	75 / 57	56,900	0.97	3.68	53,300	1.00	4.37	50,300	1.00	4.94	48,100	1.00	5.46	45,400	1.00	6.05

NOTE: Values based on 0.58" w.c. external static pressure

## ACCESSORY AIR RESISTANCE DATA - IN. W.G.

Air Volume cfm	Rectangular to Round Duct Adaptor Kits					
	Downflow			Horizontal		
	14 in. Diameter		14 in. Diameter		16 in. Diameter	18 in. Diameter
	24, 36	42, 48, 60	24, 36	42, 48, 60	42, 48, 60	42, 48, 60
500	0.03	---	0.04	---	---	---
600	0.05	---	0.07	---	---	---
700	0.08	0.13	0.08	0.13	---	---
800	0.10	0.17	0.12	0.16	---	---
900	0.12	0.21	0.15	0.21	---	---
1000	0.17	0.24	0.19	0.25	0.11	0.03
1100	0.18	0.30	0.23	0.30	0.11	0.03
1200	0.20	0.36	0.29	0.37	0.13	0.03
1300	0.26	0.43	0.31	0.43	0.17	0.03
1400	0.31	0.50	0.39	0.51	0.20	0.03
1500	---	0.57	---	0.57	0.21	0.05
1600	---	0.63	---	0.65	0.26	0.05
1700	---	0.71	---	0.72	0.30	0.06
1800	---	0.80	---	0.81	0.30	0.06
1900	---	0.91	---	0.90	0.40	0.06
2000	---	0.99	---	1.01	0.41	0.06



**DIMENSIONS (IN.) - 3.5-5 TON UNITS**

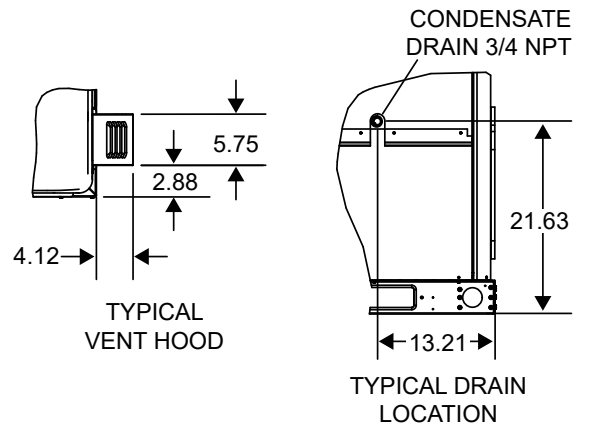
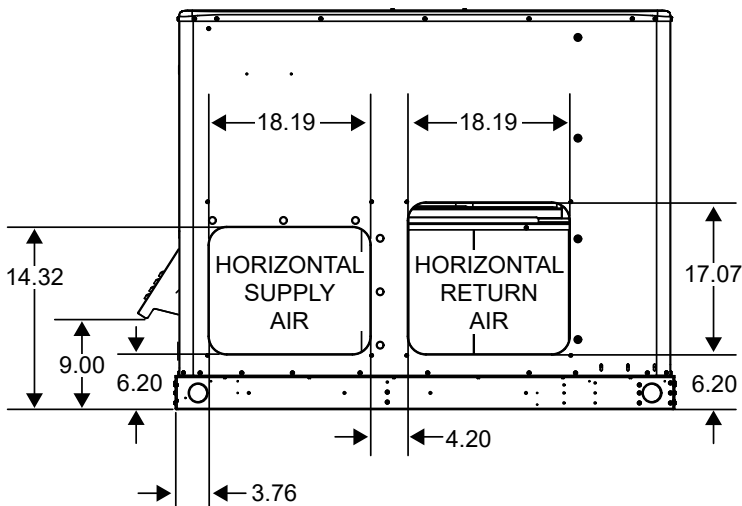
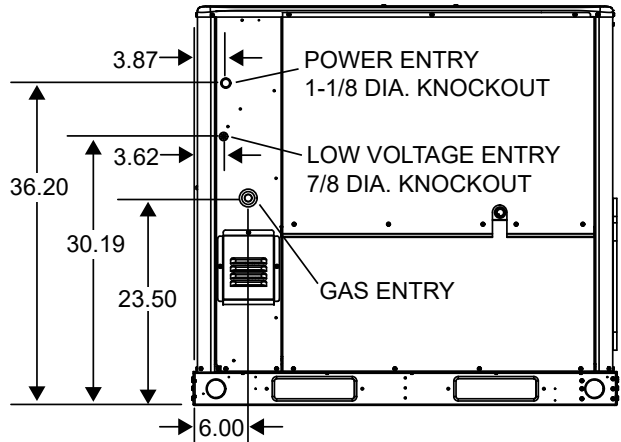
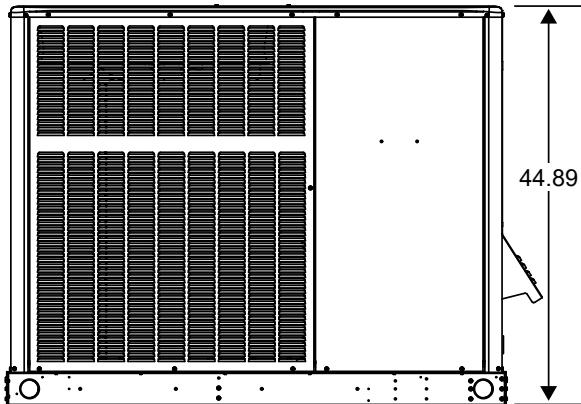
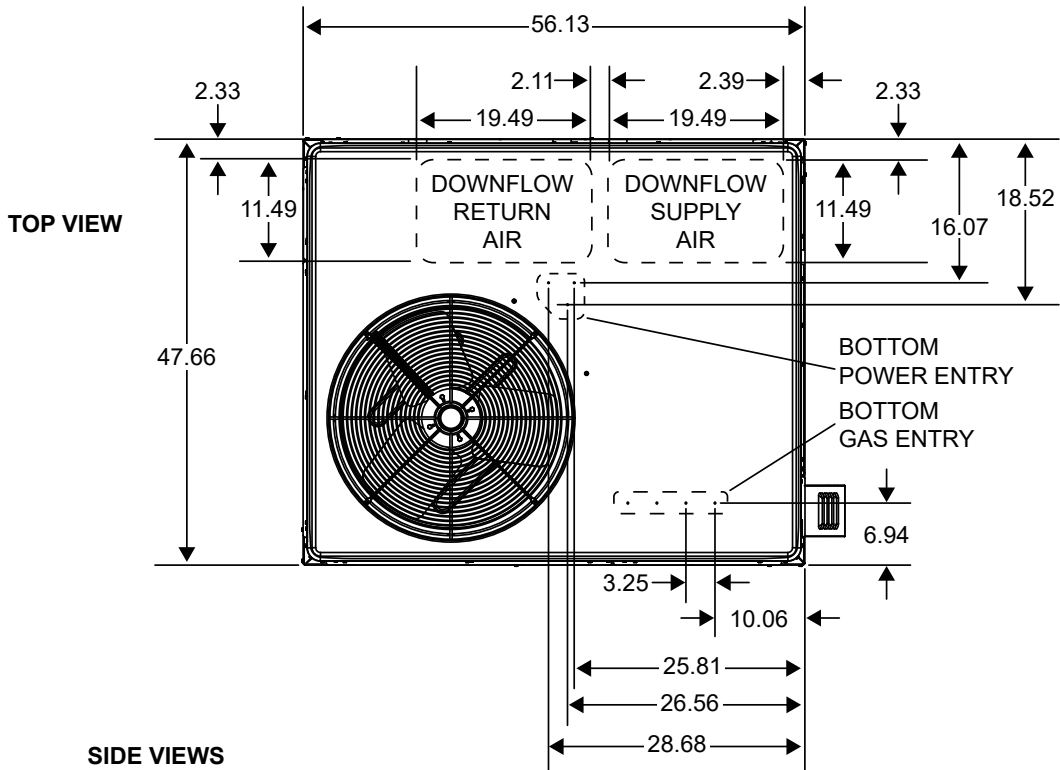

## ROOF CURB DIMENSIONS - 2-3 TON UNITS

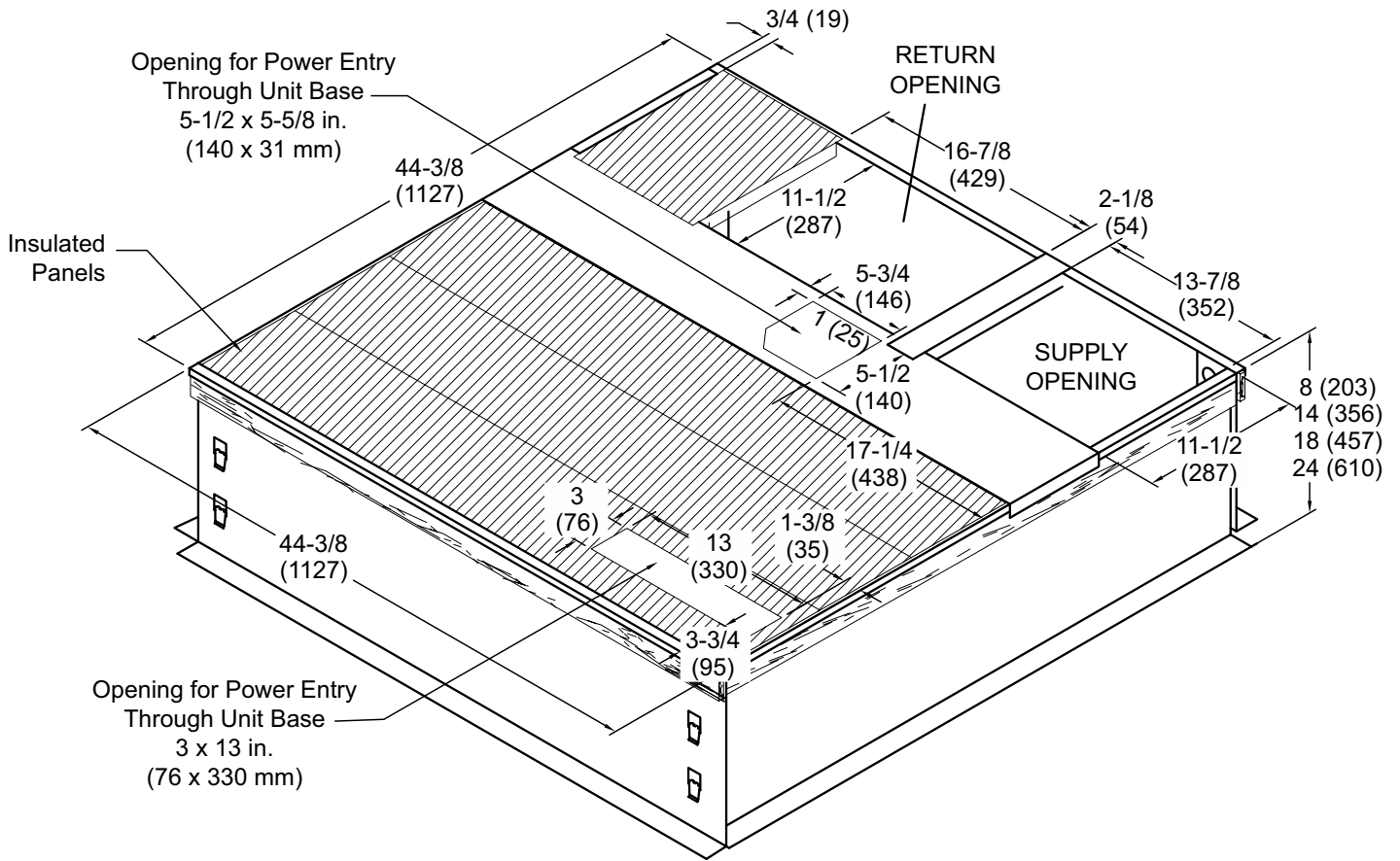

NOTE - If bottom entry is used, condensate from the heat exchanger may leak during warm ambient temperatures in humid climates. Ensure that bottom entry is watertight, if used.

NOTE - Roof deck may be omitted within confines of curb.

NOTE - All Curbs::

- IBC 2018 compliant
- CBC 2019 compliant
- Seismic rating - SDS 2.0g, z/h=1, I<sub>p</sub>=1.5
- Wind rating - 240 mph (Lateral), 214 mph (Uplift)
- Maximum load rating - 800 lbs.
- Tool-less filter access panels NOT for seismic-rated applications

## ROOF CURB DIMENSIONS - 3.5-5 TON UNITS

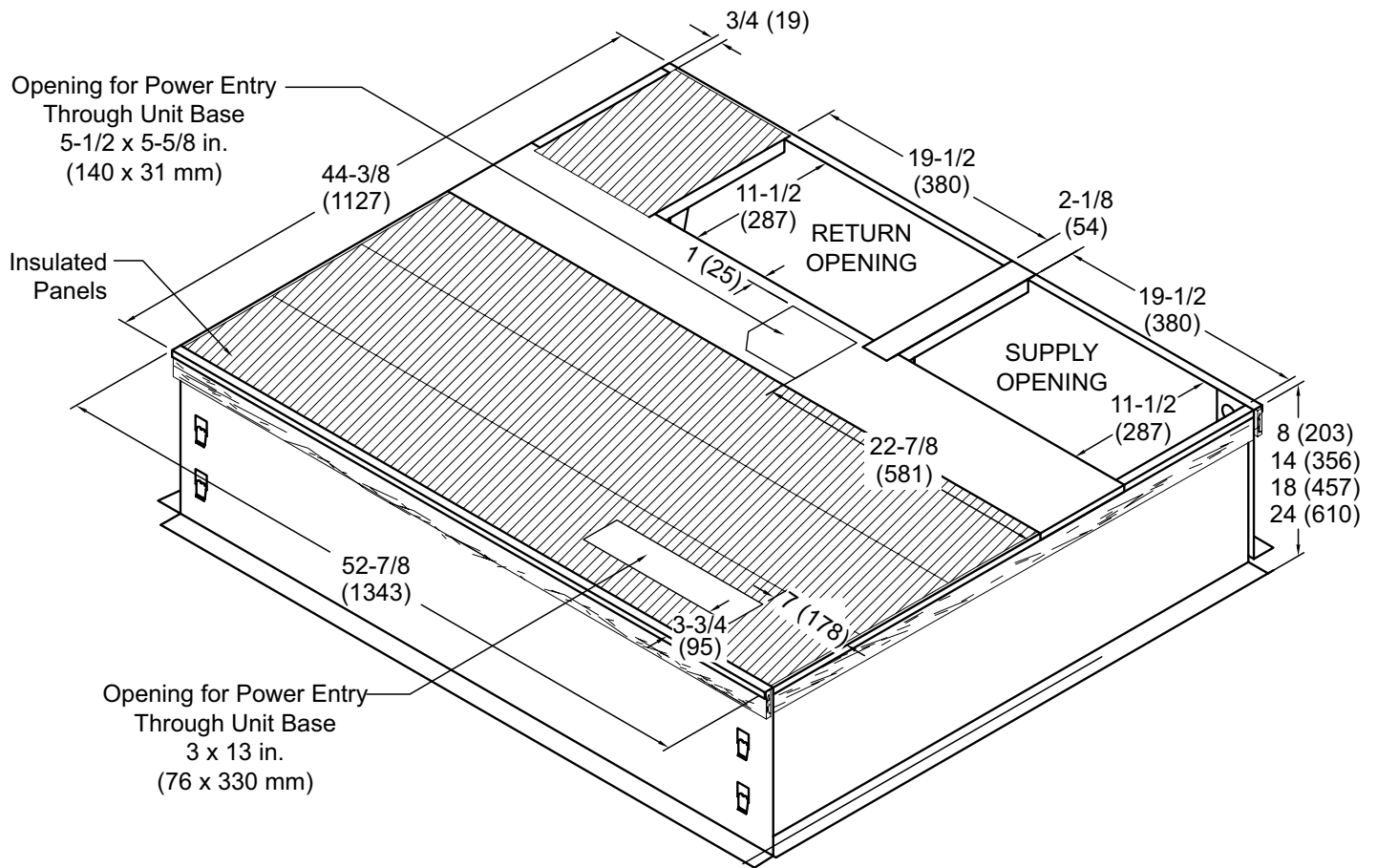

NOTE - If bottom entry is used, condensate from the heat exchanger may leak during warm ambient temperatures in humid climates. Ensure that bottom entry is watertight, if used.

NOTE - Roof deck may be omitted within confines of curb.

NOTE - All Curbs::

- IBC 2018 compliant
- CBC 2019 compliant
- Seismic rating - SDS 2.0g, z/h=1, Ip=1.5
- Wind rating - 240 mph (Lateral), 214 mph (Uplift)
- Maximum load rating - 800 lbs.
- Tool-less filter access panels NOT for seismic-rated applications

## ADJUSTABLE CURB (KNOCK-DOWN STYLE) DIMENSIONS - 2-3 TON UNITS

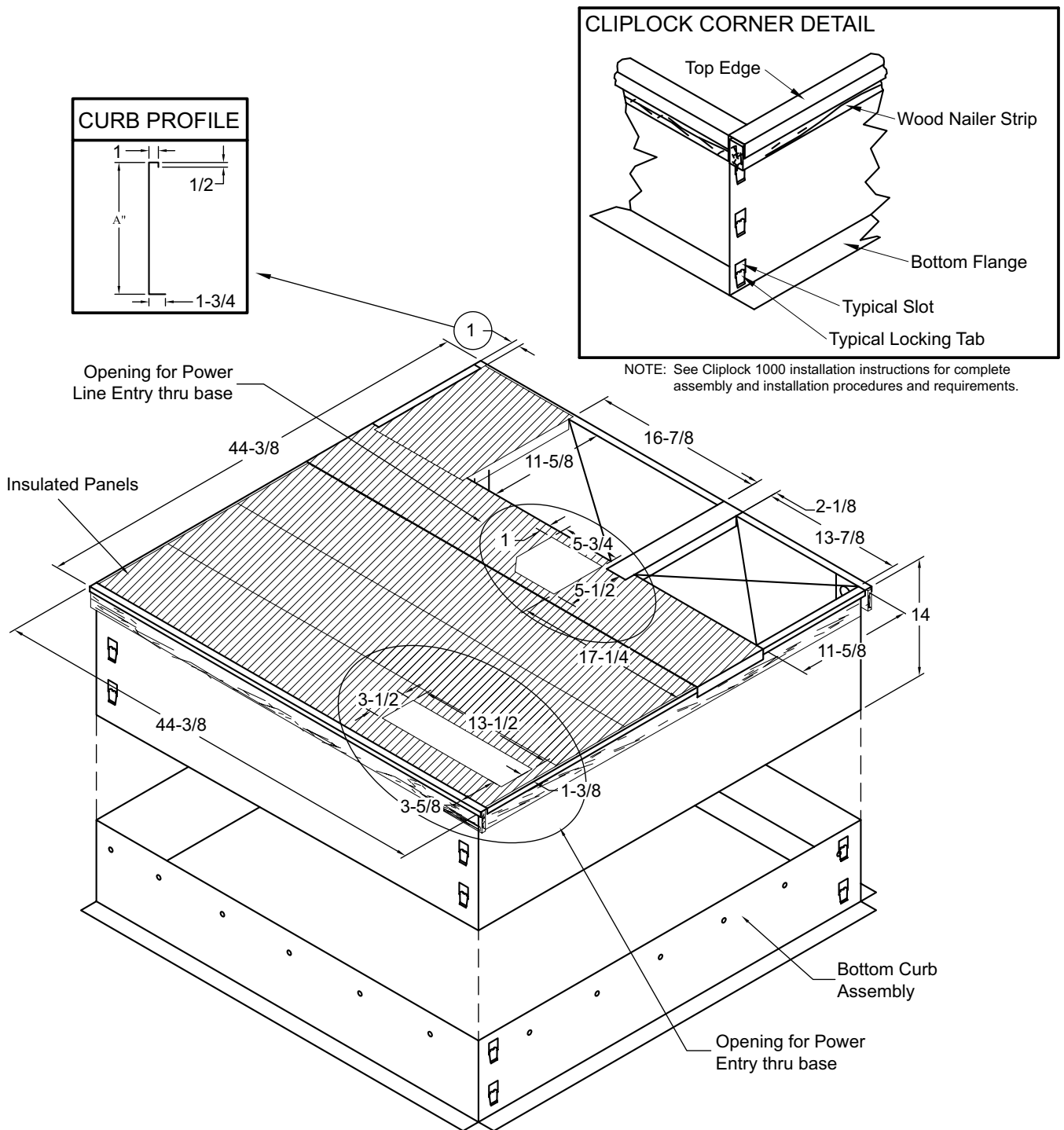

NOTE - If bottom entry is used, condensate from the heat exchanger may leak during warm ambient temperatures in humid climates. Ensure that bottom entry is watertight, if used.

NOTE - Roof deck may be omitted within confines of curb.

NOTE - All Curbs::

- IBC 2018 compliant
- CBC 2019 compliant
- Seismic rating - SDS 2.0g, z/h=1, Ip=1.5
- Wind rating - 240 mph (Lateral), 214 mph (Uplift)
- Maximum load rating - 800 lbs.
- Tool-less filter access panels NOT for seismic-rated applications

# ADJUSTABLE CURB (KNOCK-DOWN STYLE) DIMENSIONS - 3.5-5 TON UNITS

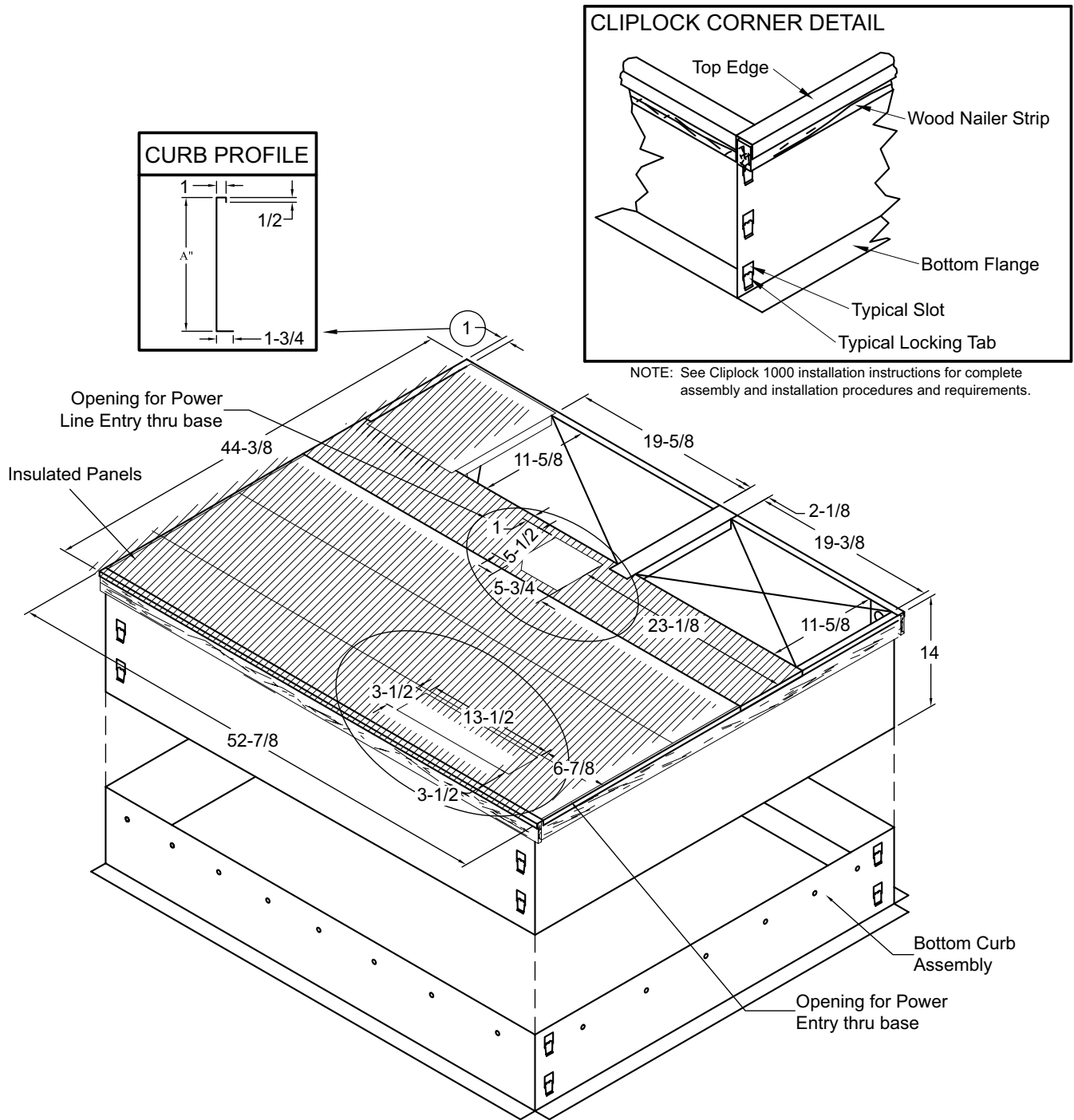

NOTE - If bottom entry is used, condensate from the heat exchanger may leak during warm ambient temperatures in humid climates. Ensure that bottom entry is watertight, if used.

NOTE - Roof deck may be omitted within confines of curb.

NOTE - All Curbs::

- IBC 2018 compliant
- CBC 2019 compliant
- Seismic rating - SDS 2.0g, z/h=1, Ip=1.5
- Wind rating - 240 mph (Lateral), 214 mph (Uplift)
- Maximum load rating - 800 lbs.
- Tool-less filter access panels NOT for seismic-rated applications

**ADJUSTABLE CURB (WELDED STYLE) DIMENSIONS**

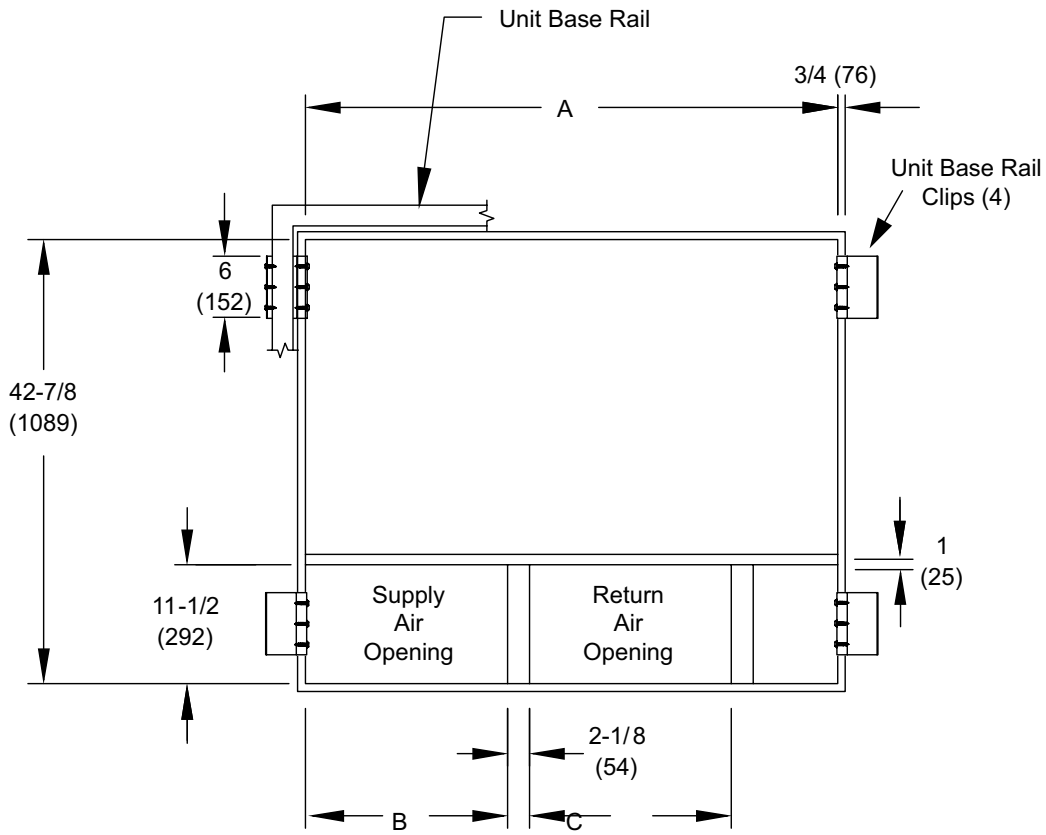
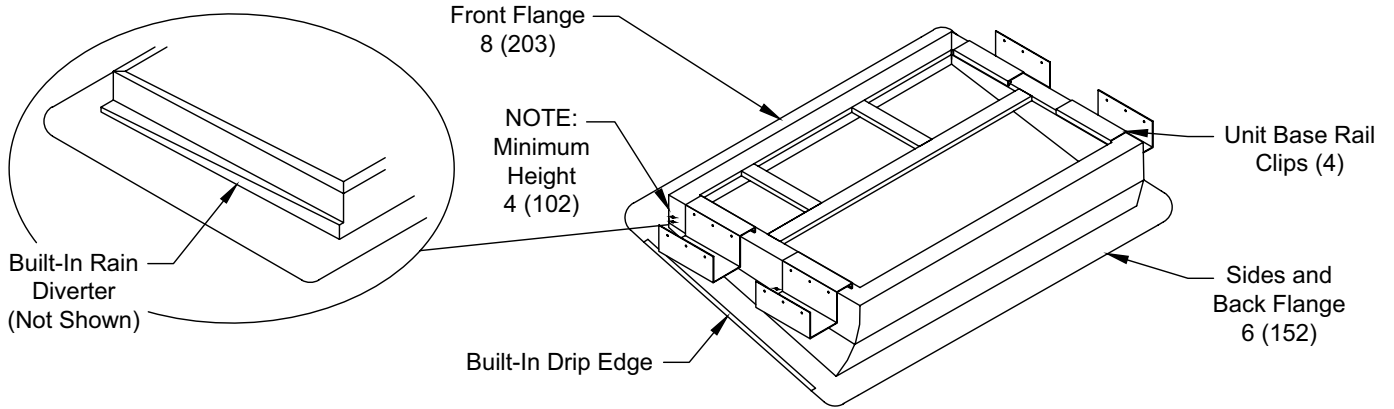

Usage	A		B		C	
	in.	mm	in.	mm	in.	mm
24,36	42-7/8	1089	13-7/8	352	16-7/8	429
42,48,60	51-3/8	1305	19-1/2	495	19-1/2	495

## ACCESSORIES LIST

Description		Where Used	Kit Number
Compressor Crankcase Heater		36, 42, 48, 60	11X27
Compressor Hard Start Kit		24, 36	10J42
		42, 48, 60	88M91
Compressor Timed-Off Control		All	47J28
Low Ambient Kit		All	21D20
Internal Filter Rack Kit		24, 36	11U73
		42, 48, 60	11U74
8" Height Full Perimeter Curb		24, 36	21J13
		42, 48, 60	21J17
14" Height Full Perimeter Curb		24, 36	21J14
		42, 48, 60	21J19
18" Height Full Perimeter Curb		24, 36	21J15
		42, 48, 60	21J20
24" Height Full Perimeter Curb		24, 36	21J16
		42, 48, 60	21J25
Adjustable Pitch Roof Curb (Knock-Down Style)		24, 36	21J26
		42, 48, 60	21U04
Adjustable Pitch Roof Curb (Welded Style)		24, 36	22V54
		42, 48, 60	22V55
Strapping Kit - Hurricane		Slab	21J74
		Rail	22G53
Strapping Kit - Seismic		All	21J75
Duct Adapter Kit - Horizontal	14 in. dia.	24, 36	21J92
	14 in. dia.	42, 48, 60	21D24
	16 in. dia.	42, 48, 60	22U78
	18 in. dia.	42, 48, 60	22U79
Duct Adapter Kit - Downflow	14 in. dia.	24, 36	20X82
	14 in. dia.	42, 48, 60	21D26
Bottom Power Entry Kit		All	21J78
Bottom Gas Entry Kit		All	22G63
Base Rail Openings - Closure Kit		All	21J84

"This product complies with all California product labeling laws including, but not limited to, the Safe Drinking Water and Toxic Enforcement Act of 1986, more commonly known as Proposition 65."

*Due to ongoing product improvements, specifications and dimensions are subject to change and correction without notice or incurring obligations. Determining the application and suitability for use of any product is the responsibility of the installer. Additionally, the installer is responsible for verifying dimensional data on the actual product prior to beginning any installation preparations. Third party incentive and rebate programs have precise requirements as to product performance and certification. All products meet applicable regulations in effect on date of manufacture; however, certifications are not necessarily granted for the life of a product. Therefore, it is the responsibility of the applicant to determine whether a specific model qualifies for these incentive/rebate programs.*