

CMA15-Series Quick-Start Addendum

FOR MOST INSTALLATIONS (Read all steps before installation – not necessarily in order) 7/16/2024

- CONFIRM PROPER CHARGE, AIRFLOW** - The CMA15-Series of inverter air conditioner condensers are designed and manufactured to meet specific levels of AHRI-Rated efficiency when matched with appropriate coils. Failure to confirm refrigerant charge and/or airflow may reduce energy efficiency, shorten equipment life, and cause nuisance service calls.
 - Systems are pre-charged for 25' of line set. Add 0.69oz per foot of additional line set beyond the factory-charged 25' length.
 - Ensure cooling airflow is nominal to the specific tonnage CMA installed (Approx. 400 cfm/ton). This includes any furnace used with matching coil.
- CHOOSE WIRING STRATEGY** – The CMA15-Series can be uniquely fitted to a variety of control options, with designated specific wiring required. All control wiring shown typical 18GA standard.

A) 2-Stage Cooling Thermostat (recommended for complete modulation)

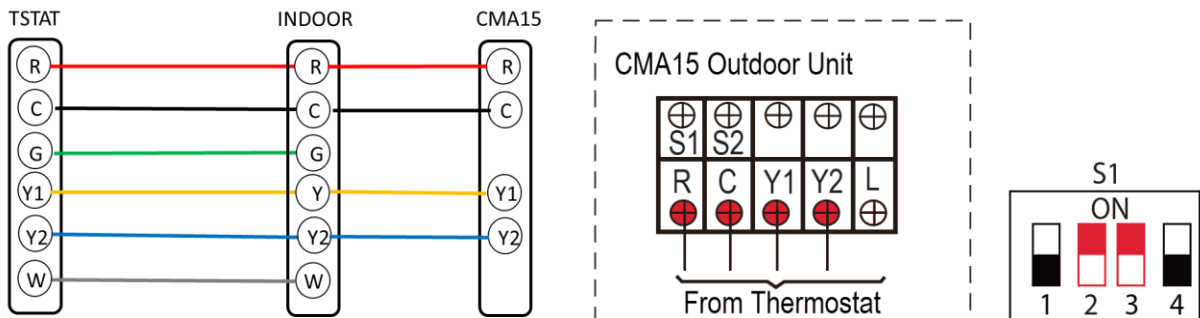

B) Single-Stage Cooling Thermostat (more aggressive modulation strategy)

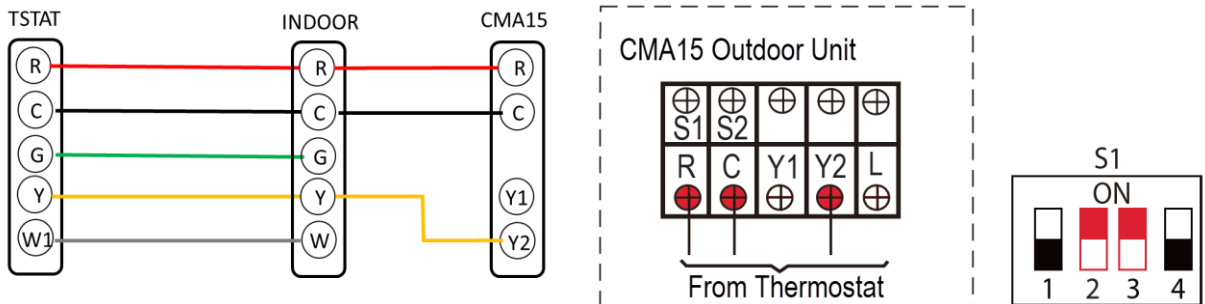

C) Alternative 2-Stage / Single-Stage Cooling Thermostat (without "R" Terminal)

Although recommended, the 24VAC Hot "R" wire does not need to be run if considerable difficulties preclude the addition of an extra wire. Note that under certain circumstances, phasing similarities between outdoor circuits and control circuits may require movement of breaker(s) to different phases to ensure differential is noted by outdoor control board.

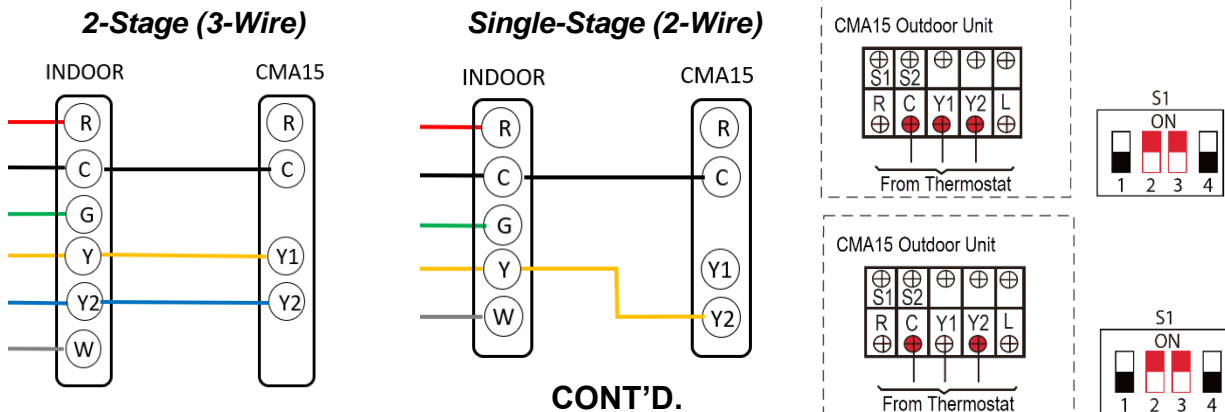

CONT'D.

CMA15-Series Quick-Start Addendum

NOTE: Outdoor Unit Low Voltage Connection Points

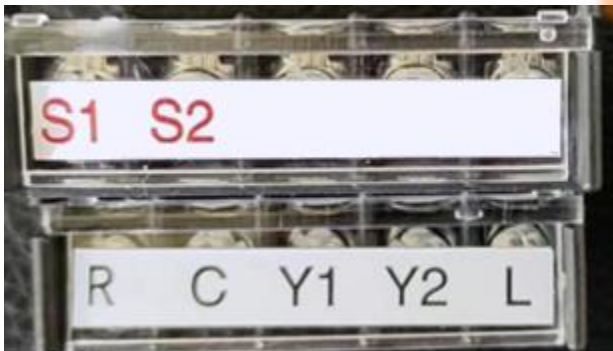

Low-Voltage Connections

- S1/S2 **NOT USED** SEE NOTE BELOW**
- "R" 24VAC Hot
- "C" Common
- "Y1" 1st Stage Compressor
- "Y2" 2nd Stage Compressor
- "L" Alarm (Optional)

****WARNING: Do not apply any combination of wiring – especially 24VAC or 208/230VAC - to S1/S2 terminals as irreversible damage will result.**

3. SET OUTDOOR DIPSWITCHES FOR APPLICATION – Power down before switch adjustments

S1 Dipswitches (Default ALL OFF) – All wiring configurations require S1-2 and S1-3 Dipswitch to be ON.

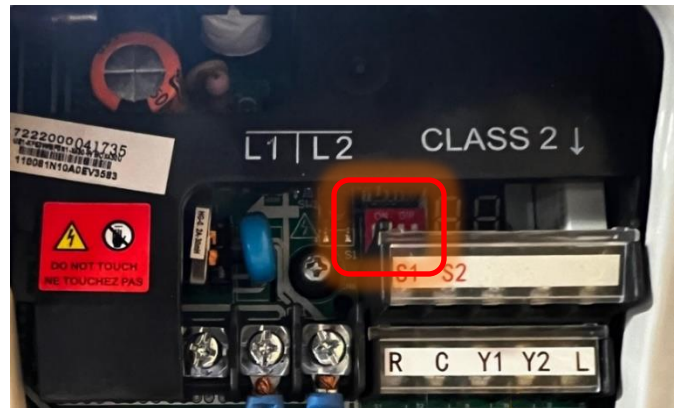
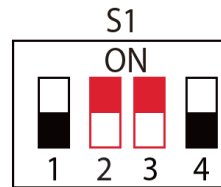

< END >