



Installation, Operation & Maintenance

Compact (HEH/HEV) Series

HEH-HEV 024-60

60Hz - HFC-410A

Table of Contents

Model Nomenclature	3
General Information	4
Unit Physical Data	6
Horizontal Installation	7
Field Conversion of Air Discharge	9
Horizontal Installation	10
Vertical Installation	11
Piping Installation	13
Variable Flow Heat Pump Applications Overview	14
Water-Loop Heat Pump Applications	17
Ground-Loop Heat Pump Applications	18
Ground-Loop and Ground Water Heat Pump Applications	19
Ground-Water Heat Pump Applications	20
Water Quality Standards	22
Electrical - Line Voltage	23
Electrical Data	25
Electrical - Power & Low Voltage Wiring	26
Electrical - Low Voltage Wiring	27
Electrical - Low Voltage Wiring for non-Variable Flow	
Units Using External Motorized Water Valve	28
Electrical - Thermostat Wiring	29
Blower Performance Data	30
ECM Blower Control	31
HE Series Wiring Diagram Matrix	32
DXM2 Controls	33
DXM2 Layout and Connections	36
DXM2 Controls	37
Unit Starting and Operating Conditions	39
Piping System Cleaning and Flushing	40
Unit and System Checkout	41
Unit Start-Up Procedure	42
Unit Operating Conditions	43
Preventive Maintenance	46
Troubleshooting	47
DXM2 Process Flow Chart	49
Functional Troubleshooting	50
Performance Troubleshooting	52
Start-Up Log Sheet	54
Functional Troubleshooting	55
Warranty	59
Revision History	60

Model Nomenclature

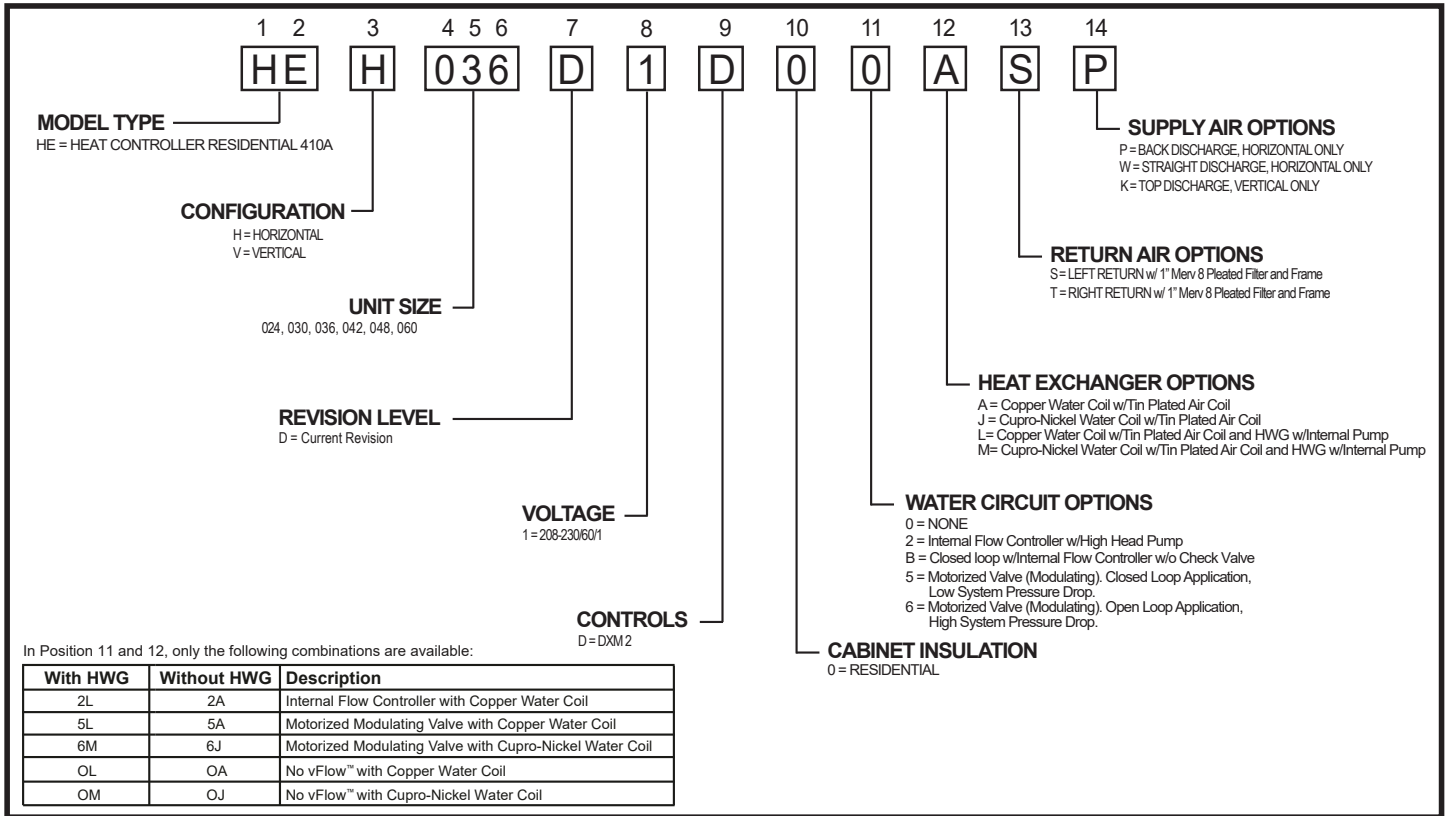

Note: Above model nomenclature is a general reference. Consult individual engineering guides for detailed information.

General Information

Safety







Warnings, cautions, and notices appear throughout this manual. Read these items carefully before attempting any installation, service, or troubleshooting of the equipment.



DANGER: Indicates an immediate hazardous situation, which if not avoided will result in death or serious injury. DANGER labels on unit access panels must be observed.

WARNING: Indicates a potentially hazardous situation, which if not avoided could result in death or serious injury.

CAUTION: Indicates a potentially hazardous situation or an unsafe practice, which if not avoided could result in minor or moderate injury or product or property damage.

NOTICE: Notification of installation, operation, or maintenance information, which is important, but which is not hazard-related.

 WARNING! 
<p>WARNING! To avoid the release of refrigerant into the atmosphere, the refrigerant circuit of this unit must be serviced only by technicians who meet local, state, and federal proficiency requirements.</p>
 CAUTION! 
<p>CAUTION! To avoid equipment damage, DO NOT use these units as a source of heating or cooling during the construction process. The mechanical components and filters can quickly become clogged with construction dirt and debris, which may cause system damage and void product warranty.</p>
 WARNING! 
<p>WARNING! The installation of water-source heat pumps and all associated components, parts, and accessories which make up the installation shall be in accordance with the regulations of ALL authorities having jurisdiction and MUST conform to all applicable codes. It is the responsibility of the installing contractor to determine and comply with ALL applicable codes and regulations.</p>

 WARNING! 
<p>WARNING! All refrigerant discharged from this unit must be recovered WITHOUT EXCEPTION. Technicians must follow industry accepted guidelines and all local, state, and federal statutes for the recovery and disposal of refrigerants. If a compressor is removed from this unit, refrigerant circuit oil will remain in the compressor. To avoid leakage of compressor oil, refrigerant lines of the compressor must be sealed after it is removed.</p>

Inspection - Upon receipt of the equipment, carefully check the shipment against the bill of lading. Make sure all units have been received. Inspect the packaging of each unit, and inspect each unit for damage. Ensure that the carrier makes proper notation of any shortages or damage on all copies of the freight bill and completes a common carrier inspection report. Concealed damage not discovered during unloading must be reported to the carrier within 15 days of receipt of shipment. If not filed within 15 days, the freight company can deny the claim without recourse.

Note: It is the responsibility of the purchaser to file all necessary claims with the carrier. Notify your equipment supplier of all damage within fifteen (15) days of shipment.

Storage - Equipment should be stored in its original packaging in a clean, dry area. Store units in an upright position at all times. Stack units a maximum of 3 units high.

Unit Protection - Cover units on the job site with either the original packaging or an equivalent protective covering. Cap the open ends of pipes stored on the job site. In areas where painting, plastering, and/or spraying has not been completed, all due precautions must be taken to avoid physical damage to the units and contamination by foreign material. Physical damage and contamination may prevent proper start-up and may result in costly equipment clean-up.

General Information, Cont'd.

Examine all pipes, fittings, and valves before installing any of the system components. Remove any dirt or debris found in or on these components.

Pre-Installation - Installation, Operation, and Maintenance instructions are provided with each unit. Horizontal equipment is designed for installation above false ceiling or in a ceiling plenum. Other unit configurations are typically installed in a mechanical room. The installation site chosen should include adequate service clearance around the unit. Before unit start-up, read all manuals and become familiar with the unit and its operation. Thoroughly check the system before operation.

Prepare units for installation as follows:

1. Compare the electrical data on the unit nameplate with ordering and shipping information to verify that the correct unit has been shipped.
2. Keep the cabinet covered with the original packaging until installation is complete and all plastering, painting, etc. is finished.
3. Verify refrigerant tubing is free of kinks or dents and that it does not touch other unit components.
4. Inspect all electrical connections. Connections must be clean and tight at the terminals.
5. Remove any blower support packaging (water-to-air units only).
6. Some airflow patterns are field convertible (horizontal units only). Locate the airflow conversion section of this IOM.
7. Locate and verify any hot water generator (HWG), hanger, or other accessory kit located in the compressor section or blower section.

CAUTION!

CAUTION! All three phase scroll compressors must have direction of rotation verified at start-up. Verification is achieved by checking compressor Amp draw. Amp draw will be substantially lower compared to nameplate values. Additionally, reverse rotation results in an elevated sound level compared to correct rotation. Reverse rotation will result in compressor internal overload trip within several minutes. Verify compressor type before proceeding.

CAUTION!

CAUTION! DO NOT store or install units in corrosive environments or in locations subject to temperature or humidity extremes (e.g., attics, garages, rooftops, etc.). Corrosive conditions and high temperature or humidity can significantly reduce performance, reliability, and service life. Always move and store units in an upright position. Tilting units on their sides will cause equipment damage.

CAUTION!

CAUTION! CUT HAZARD - Failure to follow this caution may result in personal injury. Sheet metal parts may have sharp edges or burrs. Use care and wear appropriate protective clothing, safety glasses and gloves when handling parts and servicing heat pumps.

WARNING!

WARNING! Polyolester Oil, commonly known as POE oil, is a synthetic oil used in many refrigeration systems including those with HFC-410A refrigerant. POE oil, if it ever comes in contact with the polymer drain pan, may cause the drain pan to leak. The polymer drain pan should never come in contact with POE oil as system failures and property damage may result.

Unit Physical Data

HE Two-Stage Series (60Hz Only)

Model	024	030	036	042	048	060
Compressor (1 Each)	Scroll					
Factory Charge HFC-410A (oz)	51	48	54	70	80	80
ECM Fan Motor & Blower						
Fan Motor (hp)	1/2	1/2	1/2	3/4	3/4	1
Blower Wheel Size (dia x w) - (in)	9X7	9X7	9X8	9X8	10X10	11X10
Water Connection Size						
FPT(in)	3/4"	3/4"	3/4"	3/4"	1"	1"
Coax Volume (gallons)	0.323	0.323	0.738	0.89	0.738	0.939
HWG Connection Size						
FPT(in)	1/2"					
Vertical Upflow						
Air Coil Dimensions (h x w) - (in)	20 X 17.25	20 X 17.25	24 X 21.75	24 X 21.75	28.75 X 24	28.75 X 24
Standard Filter - 1" [25.4mm] Throwaway, qty (in)	20x20	20x20	24x24	24x24	28x28	28x28
Weight - Operating, (lbs)	216	224	249	260	315	330
Weight - Packaged, (lbs)	221	229	255	266	322	337
Horizontal						
Air Coil Dimensions (h x w) - (in)	16 X 22	16 X 22	20 X 25	20 X 25	20 X 35	20 X 35
Standard Filter - 1" [25.4mm] Throwaway, qty (in)	18x25	18x25	20x28 or 2-20x14	20x28 or 2-20x14	1-20x24, 1-20x14	1-20x24, 1-20x14
Weight - Operating, (lbs)	208	208	233	244	299	314
Weight - Packaged, (lbs)	213	213	239	250	306	321

Notes:

All units have TXV expansion device and 1/2" & 3/4" electrical knockouts.

Unit Maximum Water Working Pressure	
Options	Max Pressure PSIG [kPa]
Internal Pump	145 [999]
Internal Modulating Water Valve (MWV)	300 [2,068]

Horizontal Installation

Horizontal Unit Location

Units are not designed for outdoor installation. Locate the unit in an INDOOR area that allows enough space for service personnel to perform typical maintenance or repairs without removing unit from the ceiling. Horizontal units are typically installed above a false ceiling or in a ceiling plenum. Never install units in areas subject to freezing or where humidity levels could cause cabinet condensation (such as unconditioned spaces subject to 100% outside air). Consideration should be given to access for easy removal of the filter and access panels. Provide sufficient room to make water, electrical, and duct connection(s).

If the unit is located in a confined space, such as a closet, provisions must be made for return air to freely enter the space by means of a louvered door, etc. Any access panel screws that would be difficult to remove after the unit is installed should be removed prior to setting the unit. Refer to Figure 3 for an illustration of a typical installation. Refer to unit submittal data or engineering design guide for dimensional data.

Conform to the following guidelines when selecting unit location:

1. Provide a hinged access door in concealed-spline or plaster ceilings. Provide removable ceiling tiles in T-bar or lay-in ceilings. Refer to horizontal unit dimensions for specific series and model in unit submittal data. Size the access opening to accommodate the service technician during the removal or replacement of the compressor, control, or blower assembly.
2. Provide access to hanger brackets, water valves and fittings. Provide screwdriver clearance to access panels, discharge collars and all electrical connections.
3. DO NOT obstruct the space beneath the unit with piping, electrical cables and other items that prohibit future removal of components or the unit itself.
4. Use a manual portable jack/lift to lift and support the weight of the unit during installation and servicing.

The installation of water source heat pump units and all associated components, parts and accessories which make up the installation shall be in accordance with the regulations of ALL authorities having jurisdiction and MUST conform to all applicable codes. It is the responsibility of the installing contractor to determine and comply with ALL applicable codes and regulations.

Mounting Horizontal Units

Horizontal units have 4 hanger brackets partially attached at the factory, one at each corner. Enclosed within the unit there is a hanger kit hardware bag containing vibration isolation grommets, washers, screws and a hanger installation instruction page. One additional screw from the hardware bag must be added to each hanger bracket before unit installation. Tighten each screw to 75 in-lbs (8.5 Nm). See Figure 1. Refer to the hanger installation instruction page contained in the hardware bag for details of final hanger bracket attachment and unit suspension. See Figure 1a.

Use four (4) field supplied threaded rods and factory provided vibration isolators to suspend the unit. Safely lift the unit into position supporting the bottom of the unit. Ensure the top of the unit is not in contact with any external objects. Connect the top end of the 4 all-thread rods, slide rods through the brackets and grommet then assemble washers and double nuts at each rod. Ensure that the unit is approximately level and that the threaded rod extends past the nuts.

Pitch the unit toward the drain as shown in Figure 2 to improve the condensate drainage. On small units (less than 2.5 tons/8.8kW) ensure that unit pitch does not cause condensate leaks inside the cabinet.

Figure 1: Hanger Bracket

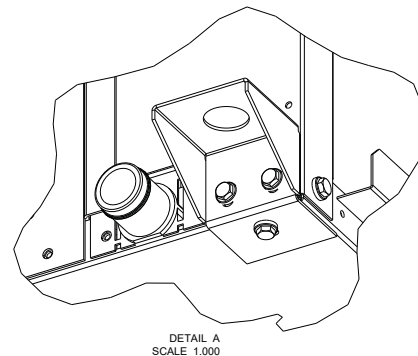
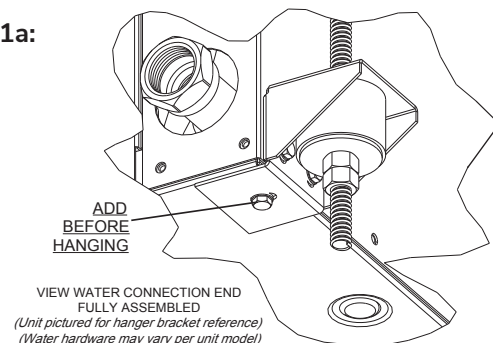

Figure 1a:



Horizontal Installation, Cont'd.

Figure 2: Horizontal Unit Pitch

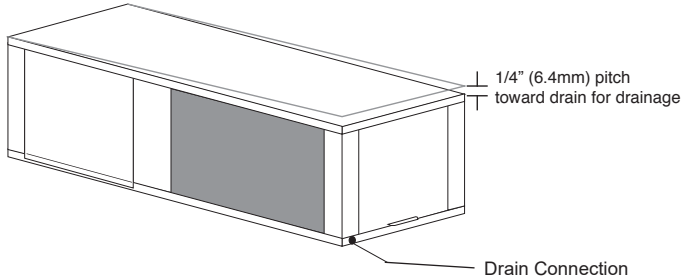
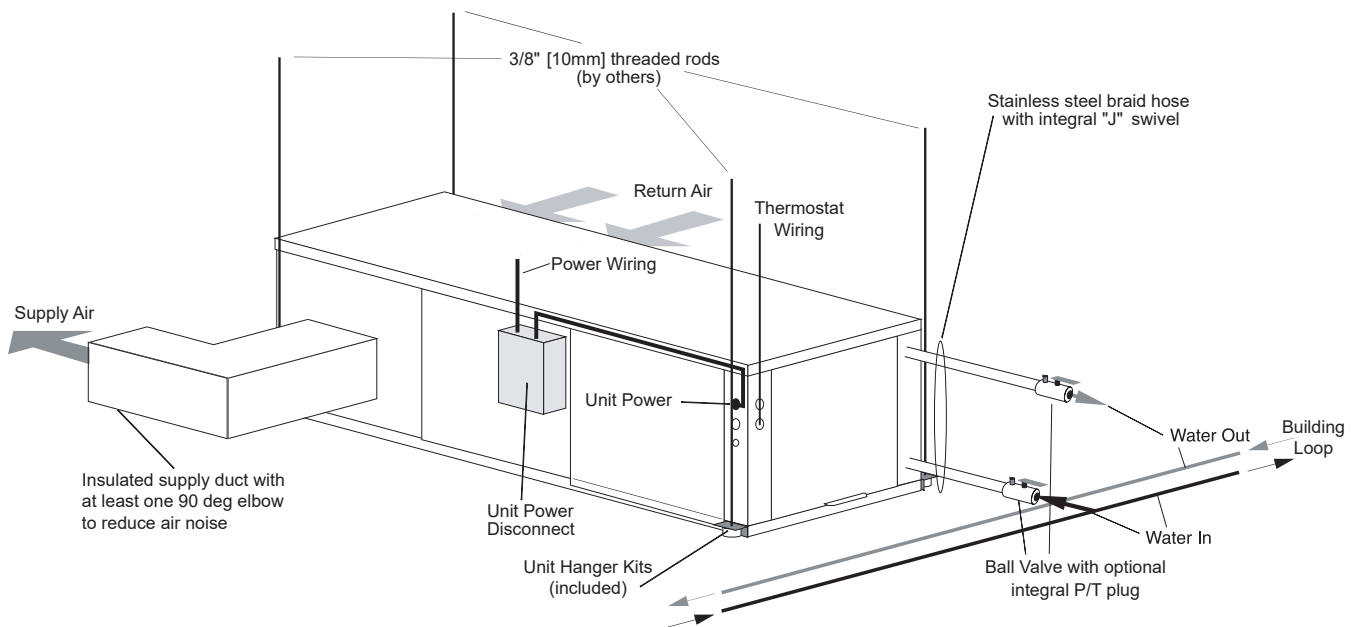

Figure 3: Typical Horizontal Unit Installation



Air Coil - To obtain maximum performance, the air coil should be cleaned before start-up. A 10% solution of dishwasher detergent and water is recommended for both sides of the coil. A thorough water rinse should follow. UV based anti-bacterial systems may damage coated air coils.

Notice! Installation Note - Ducted Return: Many horizontal WSHPs are installed in a return air ceiling plenum application (above ceiling). Vertical WSHPs are commonly installed in a mechanical room with free return (e.g. louvered door). Therefore, filter rails are the industry standard and are included on Comfort-Aire/Century commercial heat pumps for the purposes of holding the filter only. For ducted return applications, the filter rail must be removed and replaced with a duct flange or filter frame. Canvas or flexible connectors should also be used to minimize vibration between the unit and ductwork.

Field Conversion of Air Discharge

Overview - Horizontal units can be field converted between side (straight) and back (end) discharge using the instructions below.

Note: It is not possible to field convert return air between left or right return models due to the necessity of refrigeration copper piping changes.

Preparation - It is best to field convert the unit on the ground before hanging. If the unit is already hung it should be taken down for the field conversion.

Side to Back Discharge Conversion

1. Place unit in well lit area. Remove the screws as shown in Figure 4 to free top panel and discharge panel.
2. Lift out the access panel and set aside. Lift and rotate the discharge panel to the other position as shown, being careful with the blower wiring.
3. Check blower wire routing and connections for tension or contact with sheet metal edges. Re-route if necessary.
4. Check refrigerant tubing for contact with other components.
5. Reinstall top panel and screws noting that the location for some screws will have changed.
6. Manually spin the fan wheel to ensure that the wheel is not rubbing or obstructed.
7. Replace access panels.

Back to Side Discharge Conversion - If the discharge is changed from back to side, use above instruction noting that illustrations will be reversed.

Left vs. Right Return - It is not possible to field convert return air between left or right return models due to the necessity of refrigeration copper piping changes. However, the conversion process of side to back or back to side discharge for either right or left return configuration is the same. In some cases, it may be possible to rotate the entire unit 180 degrees if the return air connection needs to be on the opposite side. **Note that rotating the unit will move the piping to the other end of the unit.**

Figure 4: Left Return Side to Back

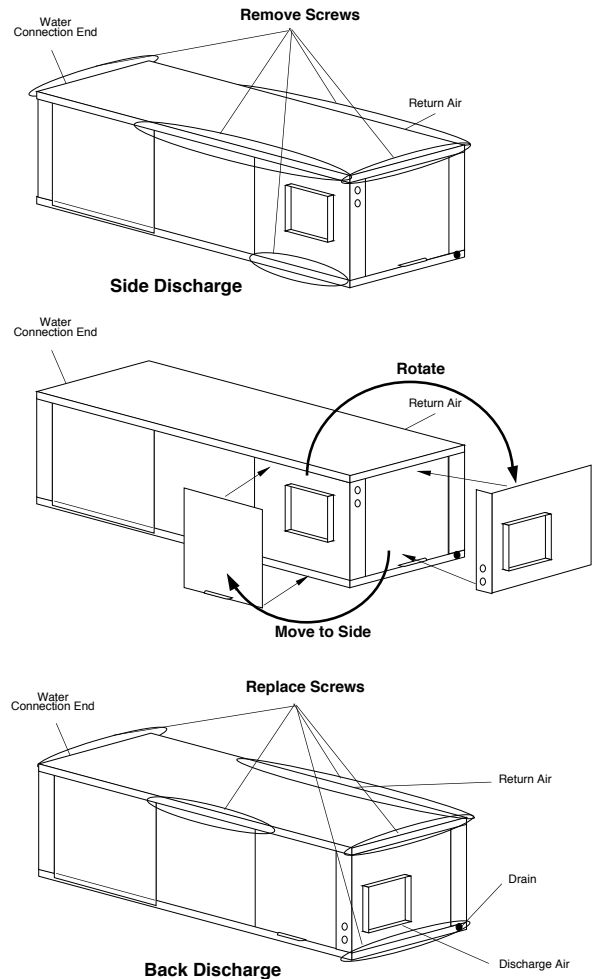
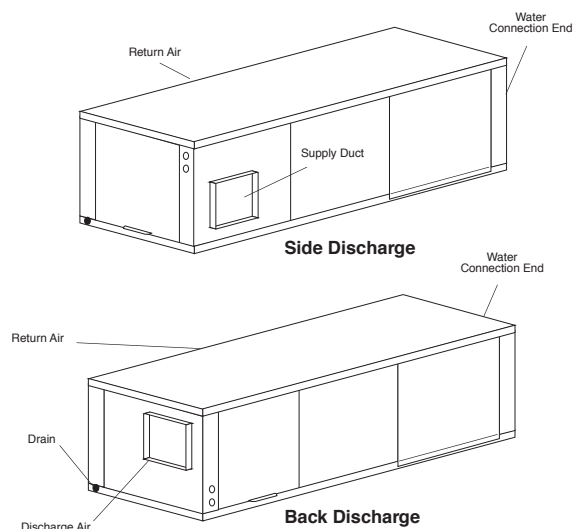

Figure 5: Right Return Side to Back



Horizontal Installation

Condensate Piping - Horizontal Units - A condensate drain line must be installed and pitched away for the unit to allow for proper drainage. This connection must meet all local plumbing/building codes.

Pitch the unit toward the drain as shown in Figure 2 to improve the condensate drainage. On small units (less than 2.5 tons/8.8 kW), ensure that unit pitch does not cause condensate leaks inside the cabinet.

Install condensate trap at each unit with the top of the trap positioned below the unit condensate drain connection as shown in Figure 6. Design the depth of the trap (water-seal) based upon the amount of ESP capability of the blower (where 2 inches [51 mm] of ESP capability requires 2 inches [51 mm] of trap depth). As a general rule, 1-1/2 inch [38 mm] trap depth is the minimum.

Each unit must be installed with its own individual trap and connection to the condensate line (main) or riser. Provide a means to flush or blow out the condensate line. **DO NOT** install units with a common trap and/or vent.

Always vent the condensate line when dirt or air can collect in the line or a long horizontal drain line is required. Also vent when large units are working against higher external static pressure than other units connected to the same condensate main since this may cause poor drainage for all units on the line. **WHEN A VENT IS INSTALLED IN THE DRAIN LINE, IT MUST BE LOCATED AFTER THE TRAP IN THE DIRECTION OF THE CONDENSATE FLOW.**

Duct System Installation - Proper duct sizing and design is critical to the performance of the unit. The duct system should be designed to allow adequate and even airflow through the unit during operation. Air flow through the unit **MUST** be at or above the minimum stated airflow for the unit to avoid equipment damage. Duct systems should be designed for quiet operation. Refer to Figure 3 for horizontal duct system details or Figure 8 for vertical duct system details. A flexible connector is recommended for both discharge and return air duct connections on metal duct systems to eliminate the transfer of vibration to the duct system. To maximize sound attenuation of the unit blower, the supply and return plenums should include internal fiberglass duct liner or be constructed from ductboard for the first few feet. Application of the unit to uninsulated ductwork in an unconditioned space is not recommended, as the unit's performance may be adversely affected.

Figure 6: Horizontal Condensate Connection

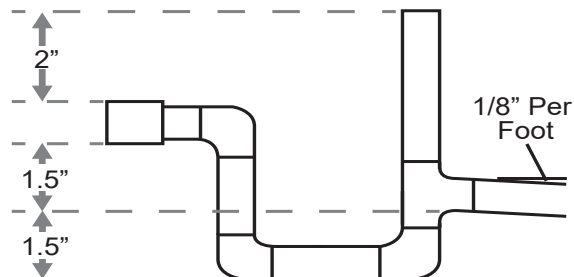

CAUTION!

CAUTION! Ensure condensate line is pitched toward drain 1/8 inch per ft [11mm per m] of run.

Condensate drain connection is a rubber coupling that couples to 3/4" schedule 40/80 PVC. Use hose clamps to secure the pipe inside the coupling. If the connection is not secure, the connection may leak.

Instructions for coupling the condensate drain to the trap are included in the bag that includes the coupling and hose clamps.

At least one 90° elbow should be included in the supply duct to reduce air noise. If air noise or excessive air flow is a problem, the blower speed can be changed. For airflow charts, consult submittal data for the series and model of the specific unit.

If the unit is connected to existing ductwork, a previous check should have been made to ensure that the ductwork has the capacity to handle the airflow required for the unit. If ducting is too small, as in the replacement of a heating only system, larger ductwork should be installed. All existing ductwork should be checked for leaks and repaired as necessary.

Vertical Installation

Vertical Unit Location - Units are not designed for outdoor installation. Locate the unit in an INDOOR area that allows enough space for service personnel to perform typical maintenance or repairs without removing unit from the mechanical room/closet. Vertical units are typically installed in a mechanical room or closet. Never install units in areas subject to freezing or where humidity levels could cause cabinet condensation (such as unconditioned spaces subject to 100% outside air). Consideration should be given to access for easy removal of the filter and access panels. Provide sufficient room to make water, electrical, and duct connection(s).

If the unit is located in a confined space, such as a closet, provisions must be made for return air to freely enter the space by means of a louvered door, etc. Any access panel screws that would be difficult to remove after the unit is installed should be removed prior to setting the unit. Refer to Figures 7 and 8 for typical installation illustrations. Refer to unit submittal data or engineering design guide for dimensional data.

1. Install the unit on a piece of rubber, neoprene or other mounting pad material for sound isolation. The pad should be at least 3/8" [10 mm] to 1/2" [13 mm] in thickness. Extend the pad beyond all four edges of the unit.
2. Provide adequate clearance for filter replacement and drain pan cleaning. Do not block filter access with piping, conduit or other materials. Refer to unit submittal data or engineering design guide for dimensional data.
3. Provide access for fan and fan motor maintenance and for servicing the compressor and coils without removing the unit.
4. Provide an unobstructed path to the unit within the closet or mechanical room. Space should be sufficient to allow removal of the unit, if necessary.
5. Provide access to water valves and fittings and screwdriver access to the unit side panels, discharge collar and all electrical connections.

Notice! Installation Note - Ducted Return: Many horizontal WSHPs are installed in a return air ceiling plenum application (above ceiling). Vertical WSHPs are commonly installed in a mechanical room with free return (e.g. louvered door). Therefore, filter rails are the industry standard and are included on Comfort-Aire/Century commercial heat pumps for the purposes of holding the filter only. For ducted return applications, the filter rail must be removed and replaced with a duct flange or filter frame. Canvas or flexible connectors should also be used to minimize vibration between the unit and ductwork.

Figure 7: Vertical Unit Mounting

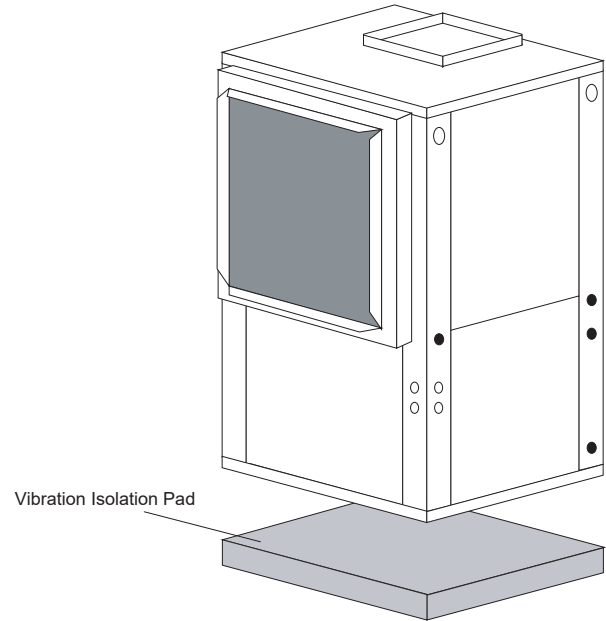
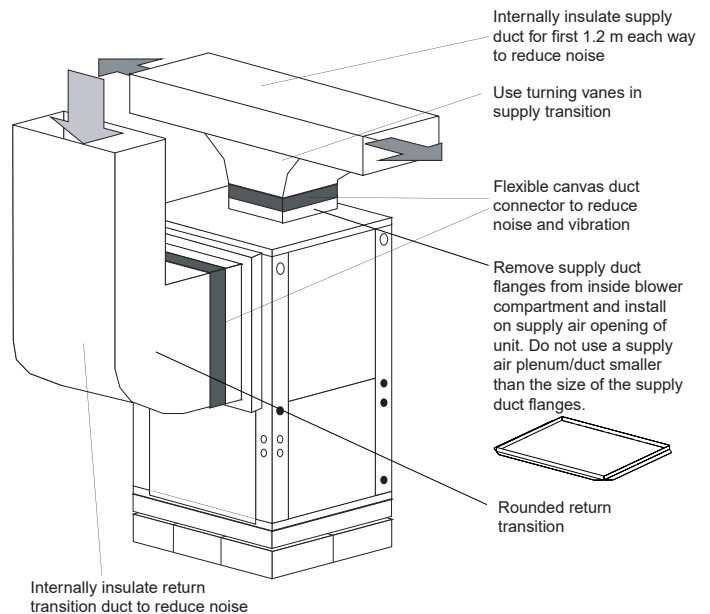

Figure 8: Typical Vertical Unit Installation Using Ducted Return Air



Vertical Installation, Cont'd.

Sound Attenuation for Vertical Units - Sound attenuation is achieved by enclosing the unit within a small mechanical room or a closet. Additional measures for sound control include the following:

1. Mount the unit so that the return air inlet is 90° to the return air grille. Refer to Figure 9. Install a sound baffle as illustrated to reduce line-of sight sound transmitted through return air grilles.
2. Mount the unit on a rubber or neoprene isolation pad to minimize vibration transmission to the building structure.

Figure 9: Vertical Sound Attenuation

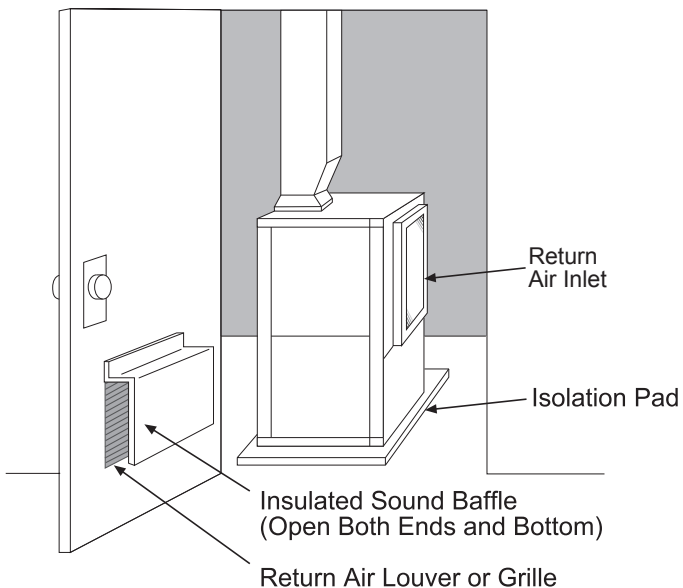

Notice! Units with clear plastic drain lines should have regular maintenance (as required) to avoid buildup of debris, especially in new construction.

Condensate Piping for Vertical Units - A condensate line must be installed and pitched away from the unit to allow for proper drainage. This connection must meet all local plumbing/building codes.

Install condensate trap at each unit with the top of the trap positioned below the unit condensate drain connection as shown in Figure 10. Design the depth of the trap (water-seal) based upon the amount of ESP capability of the blower (where 2 inches [51mm] of ESP capability requires 2 inches [51mm] of trap depth). As a general rule, 1-1/2 inch [38mm] trap depth is the minimum.

Always vent the condensate line when dirt or air can collect in the line or a long horizontal drain line is required. Also vent when large units are working against higher external static pressure than other units connected to the same condensate main since this may cause poor drainage for all units on the line. **WHEN A VENT IS INSTALLED IN THE DRAIN LINE, IT MUST BE LOCATED AFTER THE TRAP IN THE DIRECTION OF THE CONDENSATE FLOW.**

Each unit must be installed with its own individual vent (where necessary) and a means to flush or blow out the condensate drain line. Do not install units with a common trap and/or vent.

Condensate drain connection is a rubber coupling that couples to 3/4" schedule 40/80 PVC. Use hose clamps to secure the pipe inside the coupling. If the connection is not secure, the connection may leak.

Instructions for coupling the condensate drain to the trap are included in the bag that includes the coupling and hose clamps.

Piping Installation

Installation of Supply and Return Piping

Follow these piping guidelines.

1. Install a drain valve at the base of each supply and return riser to facilitate system flushing.
2. Install shut-off / balancing valves and unions at each unit to permit unit removal for servicing.
3. Place strainers at the inlet of each system circulating pump.
4. Select the proper hose length to allow slack between connection points. Hoses may vary in length by +2% to -4% under pressure.
5. Refer to Table 1. Do not exceed the minimum bend radius for the hose selected. Exceeding the minimum bend radius may cause the hose to collapse, which reduces water flow rate. Install an angle adapter to avoid sharp bends in the hose when the radius falls below the required minimum.

Insulation is not required on loop water piping except where the piping runs through unheated areas, outside the building or when the loop water temperature is below the minimum expected dew point of the pipe ambient conditions. Insulation is required if loop water temperature drops below the dew point (insulation is required for ground loop applications in most climates).

Pipe joint compound is not necessary when Teflon® thread tape is pre-applied to hose assemblies or when flared-end connections are used. If pipe joint compound is preferred, use compound only in small amounts on the external pipe threads of the fitting adapters. Prevent sealant from reaching the flared surfaces of the joint.

Note: When antifreeze is used in the loop, ensure that it is compatible with the Teflon® tape or pipe joint compound that is applied.

Maximum allowable torque for brass fittings is 30 ft-lbs [41 N-m]. If a torque wrench is not available, tighten finger-tight plus one quarter turn. Tighten steel fittings as necessary.

Optional pressure-rated hose assemblies designed specifically for use with Comfort-Aire/Century units are available. Similar hoses can be obtained from alternate suppliers. Supply and return hoses are fitted with swivel-joint fittings at one end to prevent kinking during installation.

Refer to Figure 11 for an illustration of a typical supply/return hose kit. Adapters secure hose assemblies to the unit and risers. Install hose assemblies properly and check regularly to avoid system failure and reduced service life.

! WARNING! !

WARNING! Polyolester Oil, commonly known as POE oil, is a synthetic oil used in many refrigeration systems including those with HFC-410A refrigerant. POE oil, if it ever comes in contact with PVC or CPVC piping, may cause failure of the PVC/CPVC. PVC/CPVC piping should never be used as supply or return water piping with water source heat pump products containing HFC-410A as system failures and property damage may result.

! CAUTION! !

CAUTION! Corrosive system water requires corrosion resistant fittings and hoses, and may require water treatment.

! CAUTION! !

CAUTION! Do not bend or kink supply lines or hoses.

! CAUTION! !

CAUTION! Piping must comply with all applicable codes.

Table 1: Metal Hose Minimum Bend Radii

Hose Diameter	Minimum Bend Radii
1/2" [12.7mm]	2-1/2" [6.4cm]
3/4" [19.1mm]	4" [10.2cm]
1" [25.4mm]	5-1/2" [14cm]
1-1/4" [31.8mm]	6-3/4" [17.1cm]

NOTICE! Do not allow hoses to rest against structural building components. Compressor vibration may be transmitted through the hoses to the structure, causing unnecessary noise complaints.

Figure 11: Supply/Return Hose Kit

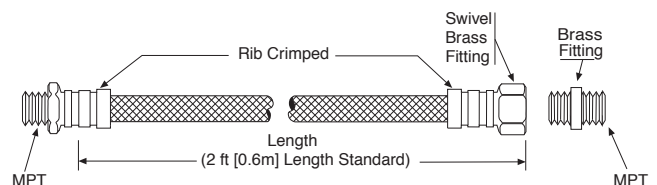

Variable Flow Heat Pump Applications Overview

Variable flow is a revolutionary new, intelligent, and efficient way to circulate water (or water plus antifreeze) using internal, variable speed water flow control. The factory installed high efficiency variable speed pumps uses almost half the wattage of traditional fixed speed pump. Variable flow technology improves the life expectancy of the unit by reducing the amount of energy required to optimize the flow of water throughout the system and also reduces the space, cost, and labor required to install external water flow control mechanisms (flow controllers, solenoid and flow control valves).

includes an internal check valve for multiple unit installations. This pump is a factory installed option for the HE unit and when selected replaces the modulating valve.



Variable speed pump or motorized modulating valve delivers variable water-flow, controlled by DXM2 control, based on loop water ΔT .

Variable Flow Configurations:

1. Low System Pressure Drop Modulating Motorized Valve – Typical for External Central Pumping.

Primarily for use on multi-unit applications with central pumping. With this option the unit includes a low pressure drop, high Cv modulating motorized water valve that is controlled by the DXM2 control based on the difference in the entering and leaving water temperature delta T.

This valve is a standard factory installed feature for the HE unit.

2. High System Pressure Drop Modulating Motorized Valve – Typical for High Pressure Water System such as Water Well Pumps.

With this option the unit includes a high pressure drop modulating water valve that is controlled by the DXM2 control based on the difference in the entering and leaving water temperature delta T. A low Cv valve is used to provide more precise control against high system pressure differential type of loops. This valve is a factory installed option for the HE unit and when selected replaces the modulating valve.

3. Standard Head Variable Pump – Typical for Multiple Unit Central Pumping.

With this option the unit includes an internal variable speed pump that is best suited to low pressure drop systems such as primary/secondary pumping. The pump speed is controlled by the DXM2 control based on the difference in the entering and leaving water temperature delta T. This pump includes an internal check valve for multiple unit installations.

This pump is a factory installed option for the HE unit and when selected replaces the modulating valve.

4. High Head Variable Pump – Typical for Individual Unit Pumping.

With this option the unit includes an internal variable speed pump that is capable of higher system pressure drops. The pump speed is controlled by the DXM2 control based on the difference in the entering and leaving water temperature delta T. This pump

Typical Closed-Loop Application (with Internal Variable Pump Shown)

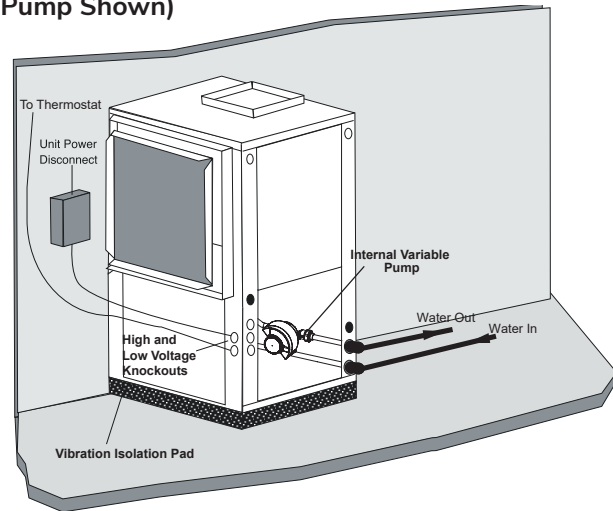

Typical Open Loop Application (with Internal Modulating Motorized Valve Shown)

For use on applications using external source for flow.

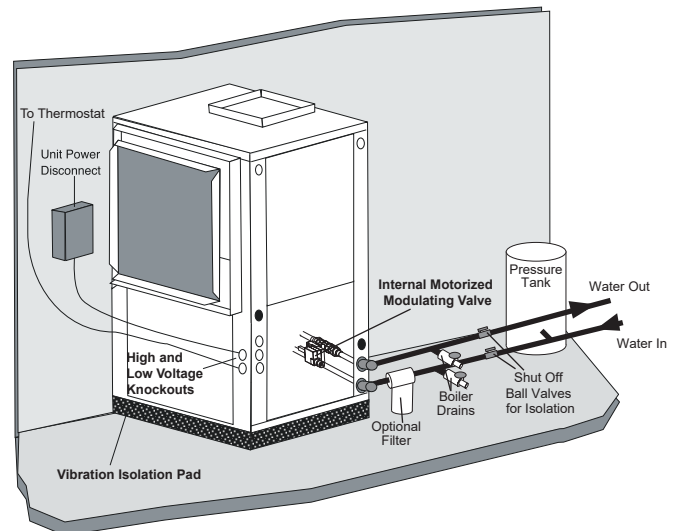

Variable Flow Heat Pump Applications Overview, Cont'd.

Water Pressure Schrader Ports

The pressure ports built in to the unit are provided as a means of measuring pressure drop through the water-to-refrigerant heat exchanger. The water pressure ports are schrader ports smaller than refrigerant schrader ports. They are the same size as tire schrader ports. A digital pressure gauge is recommended for taking pressure readings through these ports. The water flow through

the unit can be determined by measuring the water pressure at the “water pressure out” port and subtracting it from the water pressure at the “water pressure in” port. Comparing the pressure differential to the pressure drop table (wpd)/flow rate in Table 10 in this manual will determine the flow rate through the unit.

High System Pressure Drop Valve

Model	CV	MOPD	WPD Adders		
			GPM	PSI	FT
024	4.7	200	3.0	0.41	0.94
	4.7	200	4.5	0.92	2.12
	4.7	200	6.0	1.63	3.76
030	4.7	200	3.8	0.65	1.51
	4.7	200	5.6	1.42	3.28
	4.7	200	7.5	2.55	5.88
036	4.7	200	4.5	0.92	2.12
	4.7	200	6.8	2.09	4.84
	4.7	200	9.0	3.67	8.47
042	4.7	200	5.3	1.27	2.94
	4.7	200	7.9	2.83	6.53
	4.7	200	10.5	4.99	11.53
048	4.7	200	6.0	1.63	3.76
	4.7	200	9.0	3.67	8.47
	4.7	200	12.0	6.52	15.06
060	7.4	200	7.0	.89	2.06
	7.4	200	10.5	2.01	4.64
	7.4	200	14.0	3.58	8.26

Low System Pressure Drop Valve

Model	CV	MOPD	WPD Adders		
			GPM	PSI	FT
024	4.7	200	3.0	0.41	0.94
	4.7	200	4.5	0.92	2.12
	4.7	200	6.0	1.63	3.76
030	7.4	200	3.8	0.26	0.61
	7.4	200	5.6	0.57	1.32
	7.4	200	7.5	1.03	2.37
036	7.4	200	4.5	0.37	0.85
	7.4	200	6.8	0.84	1.95
	7.4	200	9.0	1.48	3.42
042	10.0	200	5.3	0.28	0.65
	10.0	200	7.9	0.62	1.44
	10.0	200	10.5	1.10	2.55
048	10.0	200	6.0	0.36	0.83
	10.0	200	9.0	0.81	1.87
	10.0	200	12.0	1.44	3.33
060	19.0	200	7.0	0.14	0.31
	19.0	200	10.5	0.31	0.70
	19.0	200	14.0	0.54	1.25

Standard Head Variable Pump Performance

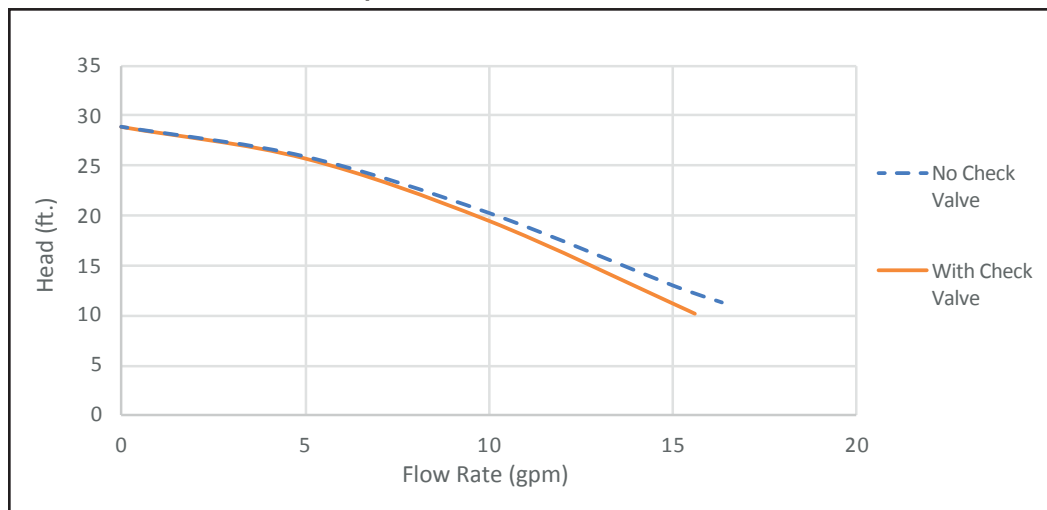

High Head Variable Pump Performance

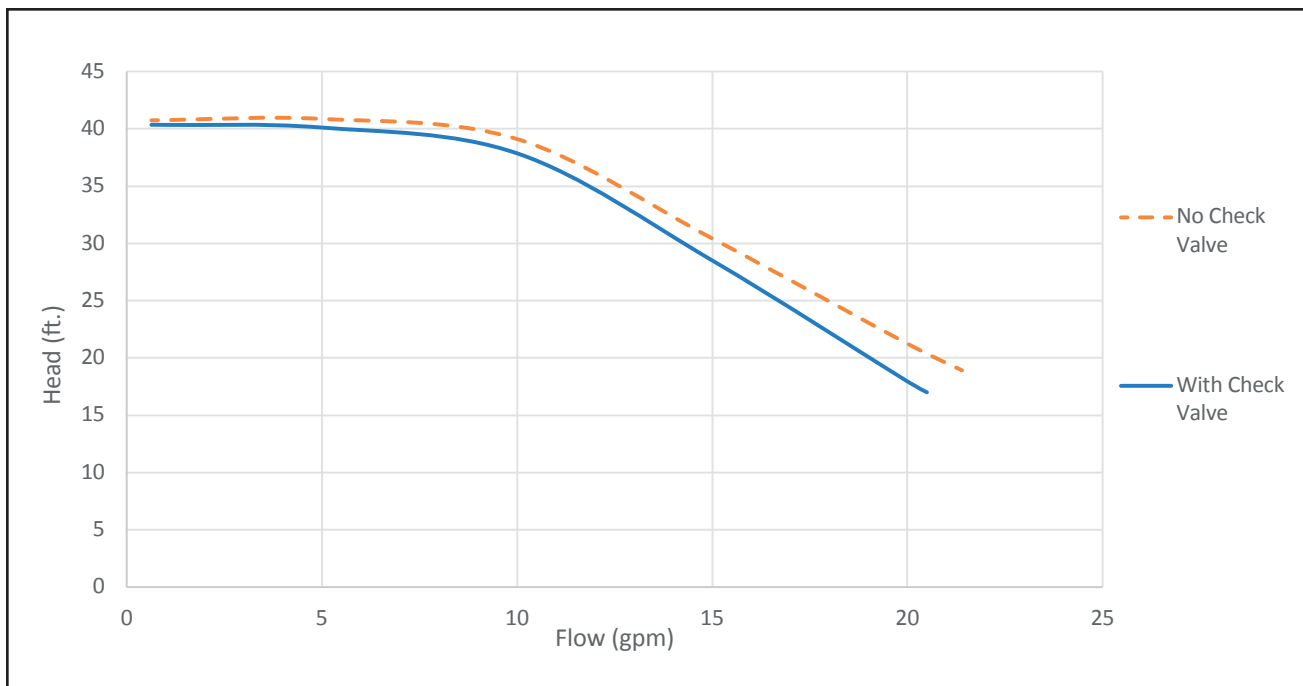

Water-Loop Heat Pump Applications

Commercial Water Loop Applications

Commercial systems typically include a number of units connected to a common piping system. Any unit plumbing maintenance work can introduce air into the piping system; therefore air elimination equipment is a major portion of the mechanical room plumbing. Consideration should be given to insulating the piping surfaces to avoid condensation. Comfort-Aire/Century recommends unit insulation any time the water temperature is expected to be below 60°F (15.6°C). Metal to plastic threaded joints should never be used due to their tendency to leak over time.

Teflon® tape thread sealant is recommended to minimize internal fouling of the heat exchanger. Do not over tighten connections and route piping so as not to interfere with service or maintenance access. Hose kits are available from Comfort-Aire/Century in different configurations for connection between the unit and the piping system. Depending upon selection, hose kits may include shut off valves, P/T plugs for performance measurement, high pressure stainless steel braided hose, "Y" type strainer with blow down valve, and/or with blow down valve, auto-flow valve and swivel connections.

The piping system should be flushed to remove dirt, piping chips, and other foreign material prior to operation (see "Piping System Cleaning and Flushing Procedures" in this manual). The flow rate is usually set between 2.25 and 3.5 gpm per ton [2.9 and 4.5 l/m per kW] of cooling capacity. Comfort-Aire/Century recommends 3 gpm per ton [3.9 l/m per kW] for most applications of water loop heat pumps. To ensure proper maintenance and servicing, P/T ports are imperative for temperature and flow verification, as well as performance checks.

Water loop heat pump (cooling tower/boiler) systems typically utilize a common loop, maintained between 60 - 90°F [16 - 32°C]. The use of a closed circuit evaporative cooling tower with a secondary heat exchanger between the tower and the water loop is recommended. If an open type cooling tower is used continuously, chemical treatment and filtering will be necessary.

Typical Water-Loop Application

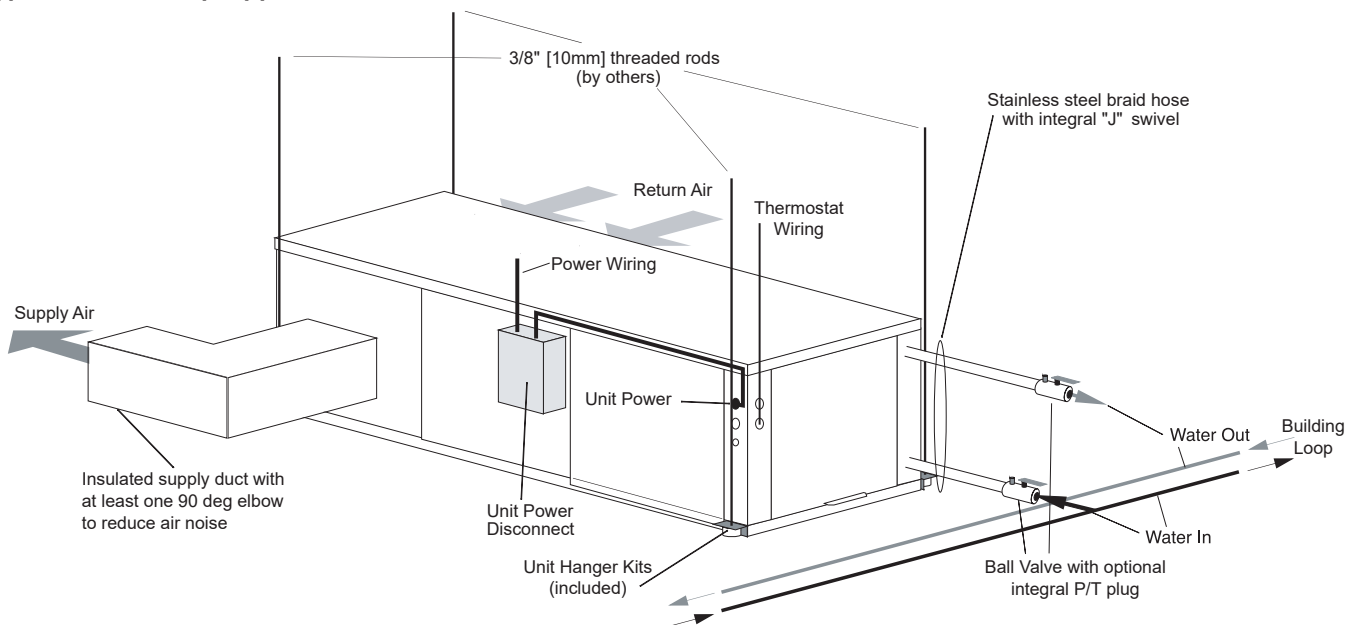

Low Water Temperature Cutout Setting - DXM2 Control

When antifreeze is selected, the LT1 jumper (JW3) should be clipped to select the low temperature (antifreeze 10.0°F [-12.2°C]) setpoint and avoid nuisance faults (see "Low Water Temperature Cutout Selection" in this manual). **Note:** Low water temperature operation requires extended range equipment.

Ground-Loop Heat Pump Applications

⚠ CAUTION! ⚠

CAUTION! The following instructions represent industry accepted installation practices for closed loop earth coupled heat pump systems. Instructions are provided to assist the contractor in installing trouble free ground loops. These instructions are recommendations only. State/provincial and local codes **MUST** be followed and installation **MUST** conform to **ALL** applicable codes. It is the responsibility of the installing contractor to determine and comply with **ALL** applicable codes and regulations.

⚠ CAUTION! ⚠

CAUTION! Ground loop applications require extended range equipment and optional refrigerant/water circuit insulation.

Pre-Installation

Prior to installation, locate and mark all existing underground utilities, piping, etc. Install loops for new construction before sidewalks, patios, driveways, and other construction has begun. During construction, accurately mark all ground loop piping on the plot plan as an aid in avoiding potential future damage to the installation.

Piping Installation

All earth loop piping materials should be limited to polyethylene fusion only for in-ground sections of the loop. Galvanized or steel fittings should not be used at any time due to their tendency to corrode. All plastic to metal threaded fittings should be avoided due to their potential to leak. A flanged fitting should be substituted. P/T plugs should be used with units that do not include variable flow so that flow can be measured using the pressure drop of the unit heat exchanger. Units equipped with any of the four variable flow configurations have built in Schrader ports. Water temperature may be viewed on the intelligent communicating thermostat.

Earth loop temperatures can range between 25 and 110°F [-4 to 43°C]. Flow rates between 2.25 and 3 gpm [2.41 to 3.23 l/m per kW] of cooling capacity is recommended in these applications.

Test individual horizontal loop circuits before backfilling. Test vertical U-bends and pond loop assemblies prior to installation. Pressures of at least 100 psi [689 kPa] should be used when testing. Do not exceed the pipe pressure rating. Test entire system when all loops are assembled.

Flushing the Earth Loop

Upon completion of system installation and testing, flush the system to remove all foreign objects and purge to remove all air.

Antifreeze

In areas where minimum entering loop temperatures drop below 40°F [5°C] or where piping will be routed through areas subject to freezing, antifreeze is required. Alcohols and glycols are commonly used as antifreeze; however your local sales office should be consulted to determine the antifreeze best suited to your area. Freeze protection should be maintained to 15°F [9°C] below the lowest expected entering loop temperature. For example, if 30°F [-1°C] is the minimum expected entering loop temperature, the leaving loop temperature would be 22 to 25°F [-6 to -4°C] and freeze protection should be at 15°F [-10°C]. Calculation is as follows:

$$30^{\circ}\text{F} - 15^{\circ}\text{F} = 15^{\circ}\text{F} \quad [-1^{\circ}\text{C} - 9^{\circ}\text{C} = -10^{\circ}\text{C}]$$

All alcohols should be premixed and pumped from a reservoir outside of the building when possible or introduced under the water level to prevent fumes. Calculate the total volume of fluid in the piping system. Then use the percentage by volume shown in table 2 for the amount of antifreeze needed. Antifreeze concentration should be checked from a well mixed sample using a hydrometer to measure specific gravity.

Low Water Temperature Cutout Setting - DXM2 Control

When antifreeze is selected, the LT1 jumper (JW3) should be clipped to select the low temperature (antifreeze 10.0°F [-12.2°C]) setpoint and avoid nuisance faults (see “Low Water Temperature Cutout Selection” in this manual). **Note: Low water temperature operation requires extended range equipment.**

Table 2: Antifreeze Percentages by Volume

Type	Minimum Temperature for Low Temperature Protection			
	10°F [-12.2°C]	15°F [-9.4°C]	20°F [-6.7°C]	25°F [-3.9°C]
Methanol	25%	21%	16%	10%
100% USP food grade Propylene Glycol	38%	25%	22%	15%
Ethanol*	29%	25%	20%	14%

* Must not be denatured with any petroleum based product

Ground-Loop and Ground-Water Heat Pump Applications

Ground-Loop Heat Pump Applications Typical Closed Loop with Central Pumping (unit with internal modulating water valve)

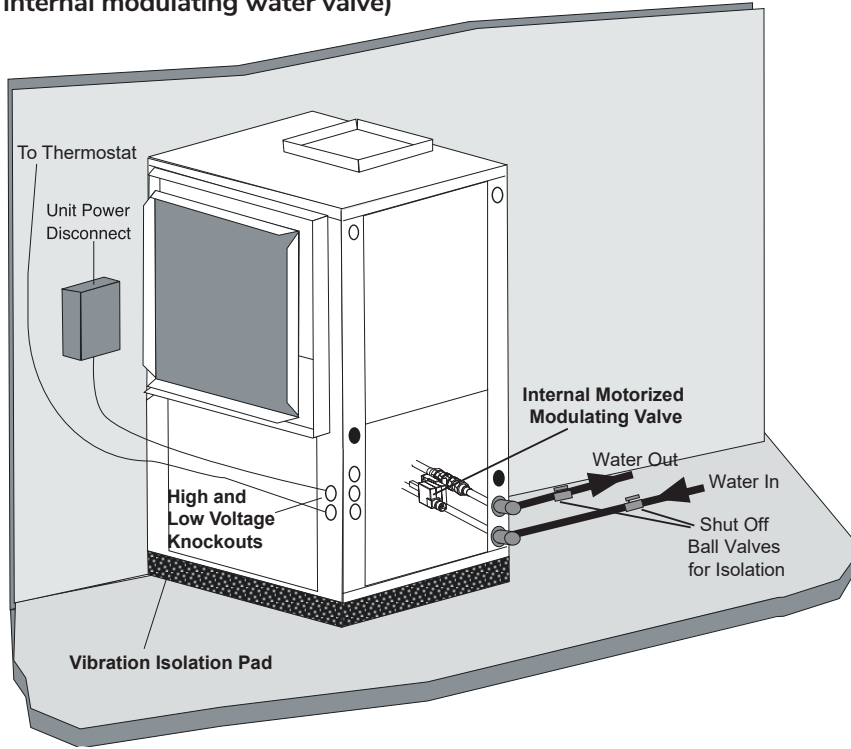

Ground Water Heat Pump Applications Typical Open Loop/Well (unit with internal modulating water valve)

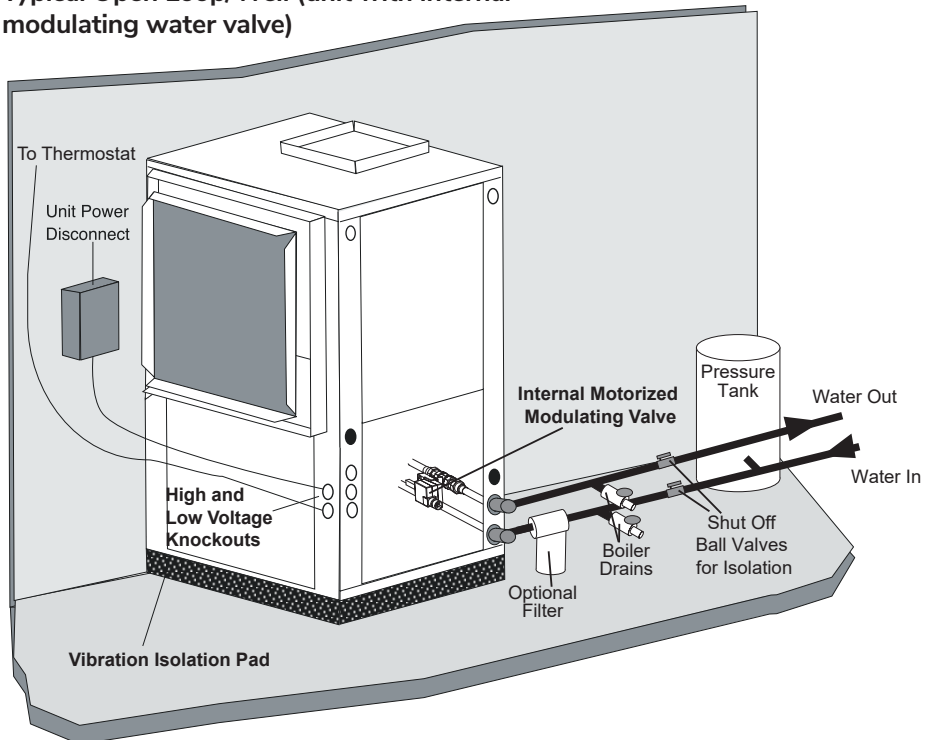

Ground-Water Heat Pump Applications

Open Loop - Ground Water Systems - Typical open loop piping is shown in accompanying illustration. Shut off valves should be included for ease of servicing. Boiler drains or other valves should be “tee’d” into the lines to allow acid flushing of the heat exchanger. Shut off valves should be positioned to allow flow through the coax via the boiler drains without allowing flow into the piping system. P/T plugs should be used with units that do not include variable flow so that flow can be measured using the pressure drop of the unit heat exchanger. Units equipped with any of the four variable flow configurations have built in Schrader ports. Water temperature may be viewed on the intelligent communicating thermostat. Supply and return water piping should be limited to copper, HPDE, or other acceptable high temperature material. Note that PVC or CPVC material is not recommended as they are not compatible with the polyolester oil used in HFC-410A products.

WARNING!

WARNING! Polyolester Oil, commonly known as POE oil, is a synthetic oil used in many refrigeration systems including those with HFC-410A refrigerant. POE oil, if it ever comes in contact with PVC or CPVC piping, may cause failure of the PVC/CPVC. PVC/CPVC piping should never be used as supply or return water piping with water source heat pump products containing HFC-410A as system failures and property damage may result.

Water quantity should be plentiful and of good quality. Consult table 3 for water quality guidelines. The unit can be ordered with either a copper or cupro-nickel water heat exchanger. Consult Table 3 for recommendations. Copper is recommended for closed loop systems and open loop ground water systems that are not high in mineral content or corrosiveness. In conditions anticipating heavy scale formation or in brackish water, a cupro-nickel heat exchanger is recommended. In ground water situations where scaling could be heavy or where biological growth such as iron bacteria will be present, an open loop system is not recommended. Heat exchanger coils may over time lose heat exchange capabilities due to build up of mineral deposits. Heat exchangers must only be serviced by a qualified technician, as acid and special pumping equipment is required. Desuperheater coils can likewise become scaled and possibly plugged. In areas with extremely hard water, the owner should be informed that the heat exchanger may require occasional acid flushing. In some cases, the desuperheater option should not be recommended due to hard water conditions and additional maintenance required.

Water Quality Standards - Table 3 should be consulted for water quality requirements. Scaling potential should be assessed using the pH/Calcium hardness method. If the pH <7.5 and the calcium hardness is less than 100 ppm, scaling potential is low. If this method yields numbers out of range of those listed, the Ryznar Stability and Langelier Saturation indices should be calculated. Use the appropriate scaling surface temperature for the application, 150°F [66°C] for direct use (well water/open loop) and DHW (desuperheater); 90°F [32°F] for indirect use. A monitoring plan should be implemented in these probable scaling situations. Other water quality issues such as iron fouling, corrosion prevention and erosion and clogging should be referenced in Table 3.

Expansion Tank and Pump - Use a closed, bladder-type expansion tank to minimize mineral formation due to air exposure. The expansion tank should be sized to provide at least one minute continuous run time of the pump using its drawdown capacity rating to prevent pump short cycling. Discharge water from the unit is not contaminated in any manner and can be disposed of in various ways, depending on local building codes (e.g. recharge well, storm sewer, drain field, adjacent stream or pond, etc.). Most local codes forbid the use of sanitary sewer for disposal. Consult your local building and zoning department to assure compliance in your area.

Water Control Valve - Units without Variable Flow - Always maintain water pressure in the heat exchanger by placing the water control valve(s) on the discharge line to prevent mineral precipitation during the off-cycle. Pilot operated slow closing valves are recommended to reduce water hammer. If water hammer persists, a mini-expansion tank can be mounted on the piping to help absorb the excess hammer shock. Ensure that the total ‘VA’ draw of the valve can be supplied by the unit transformer. For instance, a slow closing valve can draw up to 35VA. A typical pilot operated solenoid valve draws approximately 15VA. Note the special wiring diagrams for slow closing valves (shown later in this manual).

Ground-Water Heat Pump Applications, Cont'd.

Flow Regulation - Units without Variable Flow - Flow regulation can be accomplished by two methods. One method of flow regulation involves simply adjusting the ball valve or water control valve on the discharge line. Measure the pressure drop through the unit heat exchanger, and determine flow rate from Table 10. Since the pressure is constantly varying, two pressure gauges may be needed. Adjust the valve until the desired flow of 1.5 to 2 gpm per ton [2.0 to 2.6 l/m per kW] is achieved. A second method of flow control requires a flow control device mounted on the outlet of the water control valve. The device is typically a brass fitting with an orifice of rubber or plastic material that is designed to allow a specified flow rate. On occasion, flow control devices may produce velocity noise that can be reduced by applying some back pressure from the ball valve located on the discharge line. Slightly closing the valve will spread the pressure drop over both devices, lessening the velocity noise.

Note: When EWT is below 50°F [10°C], 2 gpm per ton (2.6 l/m per kW) is required.

Water Coil Low Temperature Limit Setting - For all open loop systems the 30°F [-1.1°C] LT1 setting (factory setting-water) should be used to avoid freeze damage to the unit. See "Low Water Temperature Cutout Selection" in this manual for details on the low limit setting.

Water Quality Standards

Table 3: Water Quality Standards

Water Quality Parameter	HX Material	Closed Recirculating	Open Loop and Recirculating Well		
Scaling Potential - Primary Measurement					
Above the given limits, scaling is likely to occur. Scaling indexes should be calculated using the limits below					
pH/Calcium Hardness Method	All	-	pH < 7.5 and Ca Hardness <100ppm		
Index Limits for Probable Scaling Situations - (Operation outside these limits is not recommended)					
Scaling indexes should be calculated at 66°C for direct use and HWG applications, and at 32°C for indirect HX use. A monitoring plan should be implemented.					
Ryznar Stability Index	All	-	6.0 - 7.5 If >7.5 minimize steel pipe use.		
Langelier Saturation Index	All	-	-0.5 to +0.5 If <-0.5 minimize steel pipe use. Based upon 66°C HWG and Direct well, 29°C Indirect Well HX		
Iron Fouling					
Iron Fe ²⁺ (Ferrous) (Bacterial Iron potential)	All	-	<0.2 ppm (Ferrous) If Fe ²⁺ (ferrous)>0.2 ppm with pH 6 - 8, O2<5 ppm check for iron bacteria.		
Iron Fouling	All	-	<0.5 ppm of Oxygen Above this level deposition will occur .		
Corrosion Prevention					
pH	All	6 - 8.5 Monitor/treat as needed	6 - 8.5 Minimize steel pipe below 7 and no open tanks with pH <8		
Hydrogen Sulfide (H ₂ S)	All	-	<0.5 ppm At H ₂ S>0.2 ppm, avoid use of copper and copper nickel piping or HX's. Rotten egg smell appears at 0.5 ppm level. Copper alloy (bronze or brass) cast components are OK to <0.5 ppm.		
Ammonia ion as hydroxide, chloride, nitrate and sulfate compounds	All	-	<0.5 ppm		
Maximum Chloride Levels	Maximum Allowable at maximum water temperature.				
			10°C	24°C	38°C
	Copper	-	<20ppm	NR	NR
	Cupronickel	-	<150 ppm	NR	NR
	304 SS	-	<400 ppm	<250 ppm	<150 ppm
316 SS	-	<1000 ppm	<550 ppm	< 375 ppm	
Titanium	-	>1000 ppm	>550 ppm	>375 ppm	
Erosion and Clogging					
Particulate Size and Erosion	All	<10 ppm of particles and a maximum velocity of 1.8 m/s Filtered for maximum 841 micron [0.84 mm, 20 mesh] size.	<10 ppm (<1 ppm "sandfree" for reinjection) of particles and a maximum velocity of 1.8 m/s. Filtered for maximum 841 micron 0.84 mm, 20 mesh] size. Any particulate that is not removed can potentially clog components.		

The Water Quality Table provides water quality requirements for Comfort-Aire/Century coaxial heat exchangers and fluid coolers. The water should be evaluated by an independent testing facility comparing to this Table and when properties are outside of these requirements, an external secondary heat exchanger must be used to isolate the equipment from the unsuitable water. Failure to do so will void the warranty for the coaxial heat exchanger and any other components damaged by a leak.

Notes:

- Closed Recirculating system is identified by a closed pressurized piping system.
- Recirculating open wells should observe the open recirculating design considerations.
- NR - Application not recommended.
- "-" No design Maximum.

Electrical – Line Voltage

Electrical - Line Voltage - All field installed wiring, including electrical ground, must comply with the National Electrical Code as well as all applicable local codes. Refer to the unit electrical data for fuse sizes. Consult wiring diagram for field connections that must be made by the installing (or electrical) contractor. All final electrical connections must be made with a length of flexible conduit to minimize vibration and sound transmission to the building.

General Line Voltage Wiring - Be sure the available power is the same voltage and phase shown on the unit serial plate. Line and low voltage wiring must be done in accordance with local codes or the National Electric Code, whichever is applicable.

Transformer - All 208/230 voltage units are factory wired for 208 volt. If supply voltage is 230 volt, installer must rewire transformer. See wire diagram for connections.

WARNING!

WARNING! To avoid possible injury or death due to electrical shock, open the power supply disconnect switch and secure it in an open position during installation.

CAUTION!

CAUTION! Use only copper conductors for field installed electrical wiring. Unit terminals are not designed to accept other types of conductors.

Electrical – Line Voltage, Cont'd.

Units with Modulating Motorized Valve

Model	Voltage Code	Voltage	Min/Max Voltage	Compressor			Fan Motor FLA	Total Unit FLA	Min Circ Amp	Max Fuse/HACR
				RLA	LRA	Qty				
024	1	208/230/60/1	197/252	11.7	58.3	1	3.9	15.6	18.5	30
030	1	208/230/60/1	197/252	13.1	73.0	1	3.9	17.0	20.3	30
036	1	208/230/60/1	197/252	15.3	83.0	1	3.9	19.2	23.0	35
042	1	208/230/60/1	197/252	17.9	96.0	1	5.2	23.1	27.6	45
048	1	208/230/60/1	197/252	21.2	104.0	1	5.2	26.4	31.7	50
060	1	208/230/60/1	197/252	27.1	152.9	1	6.9	34.0	40.8	60

Wire length based on one way measurement with 2% voltage drop

Wire size based on 60°C copper conductor

All fuses Class RK-5

Units with Internal Secondary Pump

Model	Voltage Code	Voltage	Min/Max Voltage	Compressor			Pump Motor FLA	Fan Motor FLA	Total Unit FLA	Min Circ Amp	Max Fuse/HACR
				RLA	LRA	Qty					
024	1	208/230/60/1	197/252	11.7	58.3	1	0.8	3.9	16.4	19.3	30
030	1	208/230/60/1	197/252	13.1	73.0	1	0.8	3.9	17.8	21.1	30
036	1	208/230/60/1	197/252	15.3	83.0	1	0.8	3.9	20.0	23.8	35
042	1	208/230/60/1	197/252	17.9	96.0	1	0.8	5.2	23.9	28.4	45
048	1	208/230/60/1	197/252	21.2	104.0	1	1.1	5.2	27.5	32.8	50
060	1	208/230/60/1	197/252	27.1	152.9	1	1.1	6.9	35.1	41.9	60

Wire length based on one way measurement with 2% voltage drop

Wire size based on 60°C copper conductor

All fuses Class RK-5

Electrical Data

Units with High Head Variable Pump

Model	Voltage Code	Voltage	Min/Max Voltage	Compressor			Pump Motor FLA	Fan Motor FLA	Total Unit FLA	Min Circ Amp	Max Fuse/HACR
				RLA	LRA	Qty					
024	1	208/230/60/1	197/252	11.7	58.3	1	1.44	3.9	17.0	20.0	30
030	1	208/230/60/1	197/252	14.7	73	1	1.44	3.9	18.4	21.7	35
036	1	208/230/60/1	197/252	18	83	1	1.44	3.9	20.6	24.5	40
042	1	208/230/60/1	197/252	21.8	96	1	1.44	5.2	24.5	29.0	45
048	1	208/230/60/1	197/252	21.2	104	1	1.44	5.2	27.8	33.1	50
060	1	208/230/60/1	197/252	28.9	152.9	1	1.44	6.9	35.4	42.2	60

Wire length based on one way measurement with 2% voltage drop

Wire size based on 60°C copper conductor

All fuses Class RK-5

Units with Standard Head Variable Pump

Model	Voltage Code	Voltage	Voltage Min/Max	Compressor			Pump Motor FLA	Fan Motor FLA	Total Unit FLA	Min Circ Amp	Max Fuse/HACR
				RLA	LRA	Qty					
024	1	208/230/60/1	197/252	11.7	58.3	1	0.7	3.9	16.3	19.2	30
030	1	208/230/60/1	197/252	14.7	73.0	1	0.7	3.9	17.7	21.0	30
036	1	208/230/60/1	197/252	18.0	83.0	1	0.7	3.9	19.9	23.7	35
042	1	208/230/60/1	197/252	21.8	96.0	1	0.7	5.2	23.8	28.3	45
048	1	208/230/60/1	197/252	25.0	104	1	0.7	5.2	27.1	32.4	50
060	1	208/230/60/1	197/252	28.9	152.9	1	0.7	6.9	34.7	41.5	60

Wire length based on one way measurement with 2% voltage drop

Wire size based on 60°C copper conductor

All fuses Class RK-5

Electrical – Power & Low Voltage Wiring

⚠ WARNING! ⚠

WARNING! Disconnect electrical power source to prevent injury or death from electrical shock.

⚠ CAUTION! ⚠

CAUTION! Use only copper conductors for field installed electrical wiring. Unit terminals are not designed to accept other types of conductors.

Power Connection - Line voltage connection is made by connecting the incoming line voltage wires to the “L” side of the contractor as shown in the unit wiring diagram. Consult electrical data tables for correct fuse size.

Transformer - All 208/230 voltage units are factory wired for 208 volt. If supply voltage is 230 volt, installer must rewire transformer. See wire diagram for connections.

Electrical - Line Voltage - All field installed wiring, including electrical ground, must comply with the National Electrical Code as well as all applicable local codes. Refer to the unit electrical data for fuse sizes. Consult wiring diagram for field connections that must be made by the installing (or electrical) contractor. All final electrical connections must be made with a length of flexible conduit to minimize vibration and sound transmission to the building.

General Line Voltage Wiring - Be sure the available power is the same voltage and phase shown on the unit serial plate. Line and low voltage wiring must be done in accordance with local codes or the National Electric Code, whichever is applicable.

ELECTRICAL - LOW VOLTAGE WIRING

Thermostat Connections - The thermostat will be wired to the CXM/DXM2 board located within the unit control box. Refer to the unit wiring diagram for specific details.

Low Water Temperature Cutout Selection - The CXM/DXM2 control allows the field selection of low water (or water-antifreeze solution) temperature limit by clipping jumper JW3, which changes the sensing temperature associated with thermistor LT1. Note that the LT1 thermistor is located on the refrigerant line between the coaxial heat exchanger and expansion device (TXV). Therefore, LT1 is sensing refrigerant temperature, not water temperature, which is a better indication of how water flow rate/temperature is affecting the refrigeration circuit.

The factory setting for LT1 is for systems using water (30°F [-1.1°C] refrigerant temperature). In low water temperature (extended range) applications with antifreeze (most ground loops), jumper JW3 should be clipped as shown in Figure 12 to change the setting to 10°F [-12.2°C] refrigerant temperature, a more suitable temperature when using an antifreeze solution. All Comfort-Aire/Century units operating with entering water temperatures below 60°F [15.6°C] must include the optional water/refrigerant circuit insulation package to prevent internal condensation.

Electrical – Low Voltage Wiring

Figure 12: LT1 Limit Setting

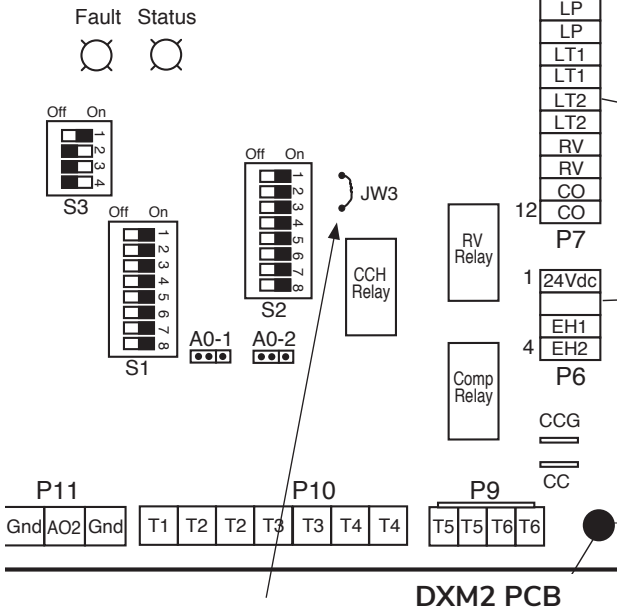

JW3-LT1 jumper should be clipped for low temperature (antifreeze) operation

Accessory Connections - A terminal paralleling the compressor contactor coil has been provided on the DXM2 control. Terminal “A” is designed to control accessory devices. Note: This terminal should be used only with 24 Volt signals and not line voltage. Terminal “A” is energized with the compressor contactor.

The DXM2 controller includes two accessory relays ACC1 and ACC2. Each relay includes a normally open (NO) and a normally closed (NC) contact. Accessory relays may be configured to operate as shown in the tables below.

Accessory Relay 1 Configuration

DIP 2.1	DIP 2.2	DIP 2.3	ACC1 Relay Option
ON	ON	ON	Cycle with fan
OFF	ON	ON	N/A for Residential Applications
ON	OFF	ON	Water valve – Slow opening
ON	ON	OFF	Outside air damper
OFF	ON	OFF	N/A for Residential Applications
OFF	OFF	OFF	N/A for Residential Applications
OFF	OFF	ON	N/A for Residential Applications
ON	OFF	OFF	N/A for Residential Applications

All other DIP combinations are invalid

Accessory Relay 2 Configuration

DIP 2.4	DIP 2.5	DIP 2.6	ACC2 Relay Option
ON	ON	ON	Cycle with compressor
OFF	ON	ON	N/A for Residential Applications
ON	OFF	ON	Water valve – Slow opening
OFF	OFF	ON	Humidifier
ON	ON	OFF	Outside air damper

All other DIP combinations are invalid

Figure 13: Accessory Wiring

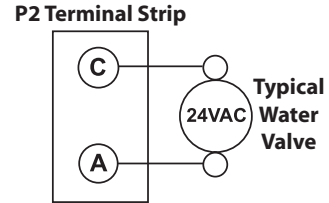

A slow closing valve may be required to help reduce water hammer. Figure 13 shows typical wiring for a 24VAC external solenoid valve. Figures 14 and 15 illustrate typical slow closing water control valve wiring for Taco 500 series and Taco SBV series valves. Slow closing valves take approximately 60 seconds to open (very little water will flow before 45 seconds). Once fully open, an end switch allows the compressor to be energized. Only relay or triac based electronic thermostats should be used with slow closing valves. When wired as shown, the slow closing valve will operate properly with the following notations:

1. The valve will remain open during a unit lockout.
2. The valve will draw approximately 25-35 VA through the “Y” signal of the thermostat.

Note: This valve can overheat the anticipator of an electromechanical thermostat. Therefore, only relay or triac based thermostats should be used.

Electrical – Low Voltage Wiring for non-Variable Flow Units Using External Motorized Water Valve

Figure 14: AVM Valve Wiring

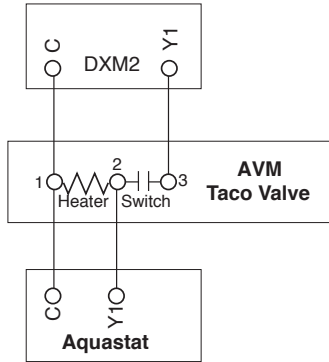

Figure 15: Taco SBV Valve Wiring

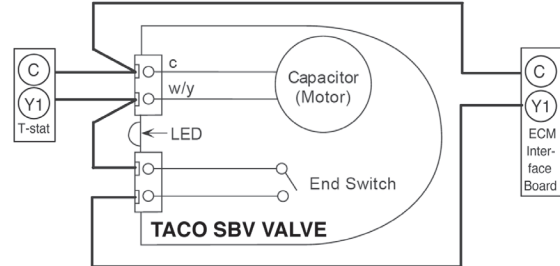
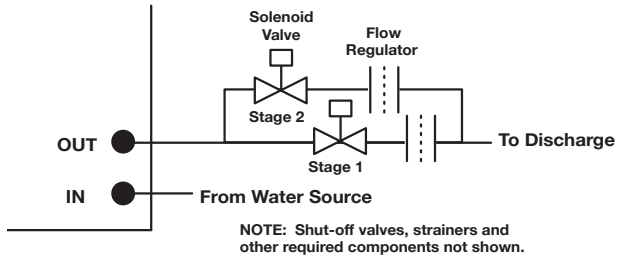

Figure 16: Two-Stage Piping



Electrical – Thermostat Wiring

Thermostat Installation - The thermostat should be located on an interior wall in a larger room, away from supply duct drafts. DO NOT locate the thermostat in areas subject to sunlight, drafts or on external walls. The wire access hole behind the thermostat may in certain cases need to be sealed to prevent erroneous temperature measurement. Position the thermostat back plate against the wall so that it appears level and so the thermostat wires protrude through the middle of the back plate. Mark

the position of the back plate mounting holes and drill holes with a 3/16" (5mm) bit. Install supplied anchors and secure plate to the wall. Thermostat wire must be 18 AWG wire. Representative thermostat wiring is shown in Figures 17a-b however, actual wiring connections should be determined from the thermostat IOM and or unit wiring diagram. Practically any heat pump thermostat will work with Comfort-Aire/Century units, provided it has the correct number of heating and cooling stages.

Figure 17a: Conventional 3 Heat / 2 Cool Thermostat Connection to DXM2 Control

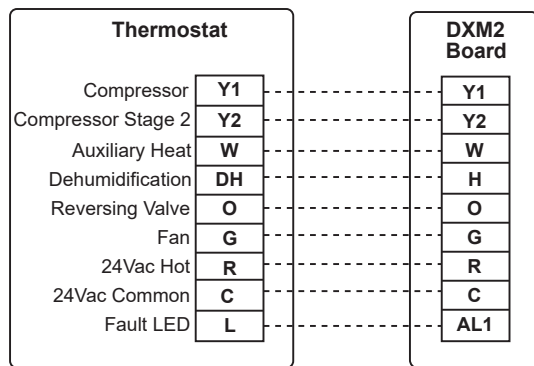
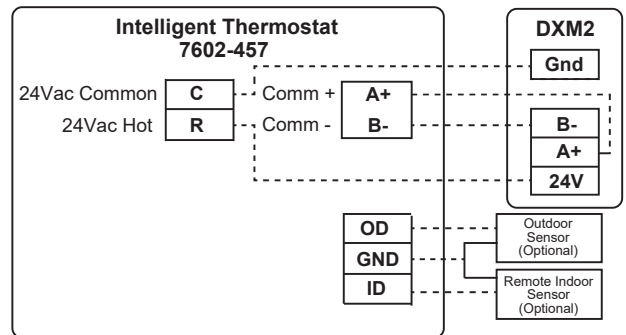
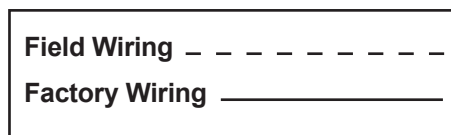

Figure 17b: Communicating Thermostat Connection to DXM2 Control



Notes:

- 1) ECM automatic dehumidification mode operates with dehumidification airflows in the cooling mode when the dehumidification output from thermostat is active. Normal heating and cooling airflows are not affected.
- 2) DXM2 board DIP switch S2-7 must be in the auto dehumidification mode for automatic dehumidification.
- 3) DH connection not possible with units with internal variable speed pump. Use 7602-457.
- 4) Only use Communicating Thermostat when using Humidifier (H Input) in units with internal variable speed pump.



Blower Performance Data

HE Standard Unit - No Reheat

Model	Max ESP (in wg)	Fan Motor (hp)	Range	Cooling Mode		Dehumid Mode		Heating Mode		Fan Only Mode	Aux Emerg Mode
				Stg 2	Stg 1	Stg 2	Stg 1	Stg 2	Stg 1		
024	0.75	1/2	Default	750	575	650	500	750	575	350	750
			Maximum	850	650	800	600	850	850	850	850
			Minimum	600	450	600	450	600	450	300	650
030	0.5	1/2	Default	950	650	800	575	950	650	450	950
			Maximum	1100	750	1000	700	1100	1100	1100	1100
			Minimum	750	525	750	525	750	525	375	750
036	0.6	1/2	Default	1125	750	975	650	1125	750	525	1125
			Maximum	1250	950	1200	800	1250	1250	1250	1250
			Minimum	900	600	900	600	900	600	450	900
042	0.6	3/4	Default	1300	925	1125	825	1300	925	600	1300
			Maximum	1475	1100	1400	1000	1475	1475	1475	1475
			Minimum	1050	750	1050	750	1050	750	525	1050
048	0.75	3/4	Default	1500	1125	1300	975	1500	1125	700	1500
			Maximum	1700	1300	1600	1200	1700	1700	1700	1700
			Minimum	1200	900	1200	900	1200	900	600	1350
060	0.75	1	Default	1875	1500	1625	1300	1875	1500	875	1875
			Maximum	2100	1700	2000	1600	2100	2100	2100	2100
			Minimum	1500	1200	1500	1200	1500	1200	750	1500

Airflow is controlled within 5% up to the Max ESP shown with wet coil.
Performance shown is with wet coil and factory air filters.

ECM Blower Control

The ECM fan is controlled directly by the DXM2 control board that converts thermostat inputs and CFM settings to signals used by the ECM motor controller. To take full advantage of the ECM motor features, a communicating multi-stage thermostat should be used (7602-457).

The DXM2 control maintains a selectable operating airflow [CFM] for each heat pump operating mode. For each operating mode there are maximum and minimum airflow limits. See the ECM Blower Performance tables for the maximum, minimum, and default operating airflows.

Airflow levels are selected using the configuration menus of a communicating thermostat (7602-457) or diagnostic tool (7602-444). The configuration menus allow the installer to independently select and adjust the operating airflow for each of the operating modes. Air flow can be selected in 25 CFM increments within the minimum and maximum limits shown in the ECM Blower Performance Table. The blower operating modes include:

- First Stage Cooling (Y1 & O)
- Second Stage Cooling (Y1, Y2, & O)
- First Stage Cooling in Dehumidification Mode (Y1, O, & Dehumid)
- Second Stage Cooling in Dehumidification Mode (Y1, Y2, O, & Dehumid)
- First Stage Heating (Y1)
- Second Stage Heating (Y1 & Y2)
- Third Stage (Auxiliary) Heating (Y1, Y2, & W)
- Emergency Heating (W with no Y1 or Y2)
- Fan (G with no Y1, Y2, or W)

It is highly recommended that 7602-457 or 7602-444 be used to set dehumidification mode electronically. Dehumidification can NOT be selected when using a non-communicating thermostat with a variable flow unit with Internal Flow Controller (pump). For dehumidification settings on other units using the non-communicating stat, refer to DXM2 AOM (part #97B0003N15).

The ECM motor includes “soft start” and “ramp down” features. The soft start feature is a gentle increase of motor rpm at blower start up. This creates a much quieter blower start cycle.

The ramp down feature allows the blower to slowly decrease rpm to a full stop at the end of each blower cycle. This creates a much quieter end to each blower cycle and adds overall unit efficiency.

The ramp down feature is eliminated during an ESD (Emergency Shut Down) situation. When the DXM2 ESD input is activated, the blower and all other control outputs are immediately de-activated.

The ramp down feature (also known as the heating or cooling “Off Delay”) is field selectable by the installer. The allowable range is 0 to 255 seconds.

Special Note for AHRI Testing:

To achieve rated airflow for AHRI testing purposes, it is necessary to change the CFM settings to rated airflow.

HE Series Wiring Diagram Matrix

All current diagrams can be located online at climatemaster.com/commercial/literature/wiring-diagrams.

Unit Controller	Fan Motor	208v/1 - 265v/1
		HE024 - 060
DXM2	CV ECM	96B0231N11
Auxiliary WD for LON		96B0147N17
Auxiliary WD for MPC		96B0147N14
Control Box Layouts		96B0500N00

DXM2 Controls

DXM2 Control - For detailed control information, see DXM2 Application, Operation and Maintenance (AOM) manual (part # 97B0003N15).

Field Selectable Inputs - Test mode: Test mode allows the service technician to check the operation of the control in a timely manner. By momentarily pressing the TEST pushbutton, the DXM2 control enters a 20 minute test mode period in which all time delays are sped up 15 times. Upon entering test mode, the status LED display will change, either flashing rapidly to indicate the control is in the test mode, or displaying a numeric flash code representing the current airflow if an ECM blower is connected and operating. For diagnostic ease at conventional thermostats, the alarm relay will also cycle during test mode. The alarm relay will cycle on and off similar to the fault LED to indicate a code representing the last fault, at the thermostat. Test mode can be exited by pressing the TEST pushbutton for 3 seconds.

Retry Mode – If the control is attempting a retry of a fault, the fault LED will slow flash (slow flash = one flash every 2 seconds) to indicate the control is in the process of retrying.

Field Configuration Options – Note: In the following field configuration options, jumper wires should be clipped ONLY when power is removed from the DXM2 control.

Water coil low temperature limit setting: Jumper 3 (JW3-LT1 Low Temp) provides field selection of temperature limit setting for LT1 of 30°F or 10°F [-1°F or -12°C] (refrigerant temperature).

Not Clipped = 30°F [-1°C]. Clipped = 10°F [-12°C].

Alarm relay setting: Jumper 1 (JW1-AL2 Dry) provides field selection of the alarm relay terminal AL2 to be jumpered to 24VAC or to be a dry contact (no connection).

Not Clipped = AL2 connected to R. Clipped = AL2 dry contact (no connection).

JUMPERS (Set at Factory)

A0-2: Configure Modulating Valve or Variable-Speed Pump

Set A0-2 jumper to "IOV" if using Internal Modulating Motorized Valve or "PMW" if using Internal Variable-Speed Pump.

DIP Switches – Note: In the following field configuration options, DIP switches should only be changed when power is removed from the DXM2 control.

DIP Package #1 (S1) – DIP Package #1 has 8 switches and provides the following setup selections:

1.1 - Unit Performance Sentinel (UPS) disable: DIP Switch 1.1 provides field selection to disable the UPS feature.

On = Enabled. Off = Disabled.

1.2 - Compressor relay staging operation: DIP 1.2 provides selection of compressor relay staging operation. The compressor relay can be selected to turn on with a stage 1 or stage 2 call from the thermostat. This is used with dual stage units (2 compressors where 2 DXM2 controls are being used) or with master/slave applications. In master/slave applications, each compressor and fan will stage according to its appropriate DIP 1.2 setting. If set to stage 2, the compressor will have a 3 second on-delay before energizing during a Stage 2 demand. Also, if set for stage 2, the alarm relay will NOT cycle during test mode.

On = Stage 1. Off = Stage 2.

1.3 - Thermostat type (heat pump or heat/cool): DIP 1.3 provides selection of thermostat type. Heat pump or heat/cool thermostats can be selected. When in heat/cool mode, Y1 is the input call for cooling stage 1; Y2 is the input call for cooling stage 2; W1 is the input call for heating stage 1; and O/W2 is the input call for heating stage 2. In heat pump mode, Y1 is the input call for compressor stage 1; Y2 is the input call for compressor stage 2; W1 is the input call for heating stage 3 or emergency heat; and O/W2 is the input call for reversing valve (heating or cooling, depending upon DIP 1.4).

On = Heat Pump. Off = Heat/Cool.

1.4 - Thermostat type (O/B): DIP 1.4 provides selection of thermostat type for reversing valve activation. Heat pump thermostats with "O" output (reversing valve energized for cooling) or "B" output (reversing valve energized for heating) can be selected with DIP 1.4.

On = HP stat with "O" output for cooling. Off = HP stat with "B" output for heating.

1.5 - Dehumidification mode: DIP 1.5 provides selection of normal or dehumidification fan mode. In dehumidification mode, the fan speed relay will remain off during cooling stage 2. In normal mode, the fan speed relay will turn on during cooling stage 2.

On = Normal fan mode. Off = Dehumidification mode.

DXM2 Controls, Cont'd.

1.6 – DDC output at EH2: DIP 1.6 provides selection for DDC operation. If set to “DDC Output at EH2,” the EH2 terminal will continuously output the last fault code of the controller. If set to “EH2 normal,” EH2 will operate as standard electric heat output.

On = EH2 Normal. Off = DDC Output at EH2.

1.7– Boilerless operation: DIP 1.7 provides selection of boilerless operation. In boilerless mode, the compressor is only used for heating when LT1 is above the temperature specified by the setting of DIP 1.8. Below DIP 1.8 setting, the compressor is not used and the control goes into emergency heat mode, staging on EH1 and EH2 to provide heating.

On = normal. Off = Boilerless operation.

1.8 – Boilerless changeover temperature: DIP 1.8 provides selection of boilerless changeover temperature setpoint. Note that the LT1 thermistor is sensing refrigerant temperature between the coaxial heat exchanger and the expansion device (TXV). Therefore, the 50°F [10°C] setting is not 50°F [10°C] water, but approximately 60°F [16°C] EWT.

On = 50°F [10°C]. Off = 40°F [16°C].

DIP Package #2 (S2) – A combination of dip switches **2.1, 2.2, 2.3, and 2.4, 2.5, 2.6** deliver configuration of ACC1 and ACC2 relay options respectively. See Table 4 for description and functionality.

2.7 – Auto dehumidification fan mode or high fan mode: DIP 2.7 provides selection of auto dehumidification fan mode or high fan mode. In auto dehumidification mode, the fan speed relay will remain off during cooling stage 2 IF the H input is active. In high fan mode, the fan enable and fan speed relays will turn on when the H input is active.

On = Auto dehumidification mode (default). Off = High fan mode.

2.8 – Special factory selection: DIP 2.8 provides special factory selection. Normal position is “On”. Do not change selection unless instructed to do so by the factory.

Table 4: Accessory DIP Switch Settings

DIP 2.1	DIP 2.2	DIP 2.3	ACC1 Relay Option
On	On	On	Cycle with fan
Off	On	On	Digital NSB
On	Off	On	Water Valve - slow opening
On	On	Off	OAD
Off	Off	Off	Reheat Option - Humidistat
Off	On	Off	Reheat Option - Dehumidistat
DIP 2.4	DIP 2.5	DIP 2.6	ACC2 Relay Option
On	On	On	Cycle with compressor
Off	On	On	Digital NSB
On	Off	On	Water Valve - slow opening
On	On	Off	OAD

All other DIP combinations are invalid

DIP Package #3 (S3)

– DIP Package #3 has 4 switches and provides the following setup and operating selections:

3.1 – Communications configuration: DIP 3.1 provides selection of the DXM2 operation in a communicating system. The DXM2 may operate as the Master of certain network configurations. In most configurations the DXM2 will operate as a master device.

On = Communicating Master device (default).
Off = Communicating Slave device.

3.2 – HWG Test Mode: DIP 3.2 provides forced operation of the HWG pump output, activating the HWG pump output for up to five minutes.

On = HWG test mode. Off = Normal HWG mode (default).

3.3 – HWG Temperature: DIP 3.3 provides the selection of the HWG operating setpoint.

On = 150°F [66°C]. Off = 125°F [52°C] (default).

3.4 – HWG Status: DIP 3.4 provides HWG operation control.

On = HWG mode enabled. Off = HWG mode disabled (default).



CAUTION! Do not restart units without inspection and remedy of faulting condition. Equipment damage may occur.

DXM2 Controls, Cont'd.

Table 5: LED and Alarm Relay Output Table

DXM2 CONTROLLER FAULT CODES			
DMX2 Fault and Status LED Operation with Test Mode Not Active	Fault LED (Red)	Status LED (Green)	Alarm Relay
DXM2 Is Non-Functional	Off	Off	Open
Normal Operation - No Active Communications	On	On	Open
Normal Operation - With Active Communications	Very Slow Flash	ON	Open
Control Is Currently In Fault Retry Mode	Slow Flash	-	Open
Control Is Currently Locked Out	Fast Flash	-	Closed
Control Is Currently In An Over/ Under Voltage Condition	Slow Flash	-	Open (Closed After 15 min)
Hot Water Mode Active	-	Slow Flash	Open
(NSB) Night Setback Condition Recognized	-	Flashing Code 2	-
(ESD) Emergency Shutdown Condition Recognized	-	Flashing Code 3	-
Invalid Thermostat Input Combination	-	Flashing Code 4	-
High Hot Water Temperature Lockout Active	-	Flashing Code 5	-
Hot Water Mode Sensor Fault Active	-	Flashing Code 6	-
DMX2 Fault LED and Status Operation with Test Mode Active	Fault LED (Red)	Status LED (Green)	Alarm Relay
No Fault Since Power Up In Memory	Flashing Code 1	-	Cycling Code 1
High Pressure Fault In Memory	Flashing Code 2	-	Cycling Code 2
Low Pressure Fault In Memory	Flashing Code 3	-	Cycling Code 3
Low Temperature Protection 1 In Fault Memory	Flashing Code 4	-	Cycling Code 4
Low Temperature Protection 2 In Fault Memory	Flashing Code 5	-	Cycling Code 5
Condensate Overflow Fault In Memory	Flashing Code 6	-	Cycling Code 6
Over/Under Voltage Shutdown In Memory	Flashing Code 7	-	Cycling Code 7
UPS Warning In Memory	Flashing Code 8	-	Cycling Code 8
UPT Fault In Memory	Flashing Code 9	-	Cycling Code 9
ECM Air Flow Fault In Memory	Flashing Code 10	-	Cycling Code 10
Test Mode Active With No ECM Connected Or Operating	-	Fast Flash	-
Test Mode Active With ECM Operating	-	Flashing ECM Airflow	-

- Fast Flash = 2 flashes every 1 second.
- Slow Flash = 1 flash every 2 seconds.
- Very Slow Flash = 1 flash every 5 seconds.
- Numeric Codes = On pulse 1/3 second; Off pulse 1/3 second followed by a 10 second delay.
- ECM Airflow = 1 flash per 100 CFM; On pulse 1/3 second followed by a 10 second delay.
- Alarm Relay Open = alarm signal off; Alarm Relay Closed = alarm signal on.

DXM2 Layout and Connections

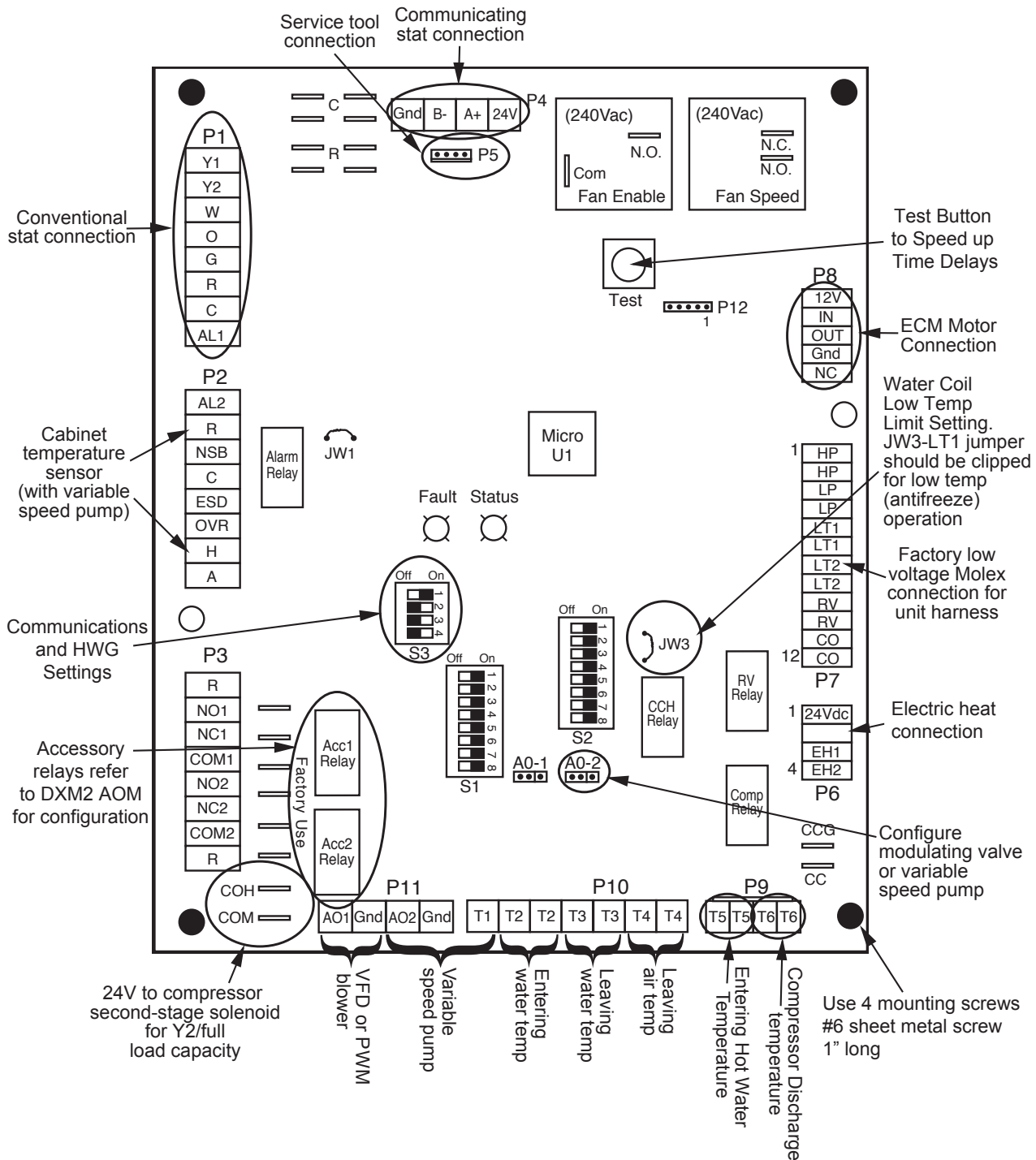

DXM2 Controls

DXM2 Control Start-up Operation – The control will not operate until all inputs and safety controls are checked for normal conditions. The compressor will have a 5 minute anti-short cycle delay at power-up. The first time after power-up that there is a call for compressor, the compressor will follow a 5 to 80 second random start delay. After the random start delay and anti-short cycle delay, the compressor relay will be energized. On all subsequent compressor calls, the random start delay is omitted.

Table 6: Unit Operation

Conventional T-stat signal (Non-Communicating)	Unit
	ECM fan
G	Fan only
G, Y1	Stage 1 heating ¹
G, Y1, Y2	Stage 2 heating ¹
G, Y1, Y2, W	Stage 3 heating ¹
G, W	Emergency heat
G, Y1, O	Stage 1 cooling ²
G, Y1, Y2, O	Stage 2 cooling ²

¹ Stage 1 = 1st stage compressor, 1st stage fan operation
 Stage 2 = 2nd stage compressor, 2nd stage fan operation
 Stage 3 = 2nd stage compressor, auxiliary electric heat, 3rd stage fan operation

² Stage 1 = 1st stage compressor, 1st stage fan operation, reversing valve
 Stage 2 = 2nd stage compressor, 2nd stage fan operation, reversing valve

Figure 18: Test Mode Button

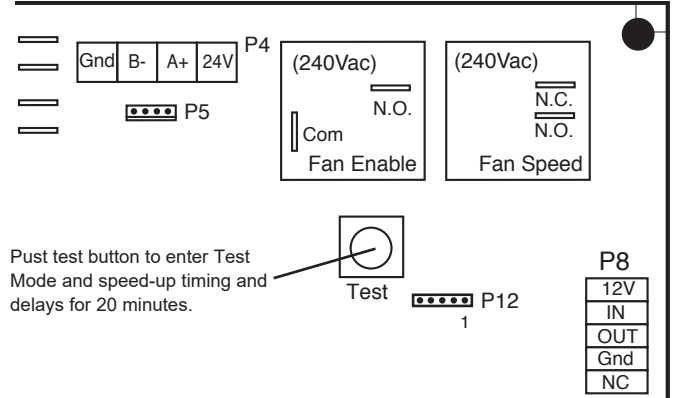

DXM2 Controls, Cont'd.

Table 7: Nominal Resistance at Various Temperatures

Temp (°C)	Temp (°F)	Resistance (kOhm)	Temp (°C)	Temp (°F)	Resistance (kOhm)
-17.8	0.0	85.34	55	131.0	2.99
-17.5	0.5	84.00	56	132.8	2.88
-16.9	1.5	81.38	57	134.6	2.77
-12	10.4	61.70	58	136.4	2.67
-11	12.2	58.40	59	138.2	2.58
-10	14.0	55.30	60	140.0	2.49
-9	15.8	52.38	61	141.8	2.40
-8	17.6	49.64	62	143.6	2.32
-7	19.4	47.05	63	145.4	2.23
-6	21.2	44.61	64	147.2	2.16
-5	23.0	42.32	65	149.0	2.08
-4	24.8	40.15	66	150.8	2.01
-3	26.6	38.11	67	152.6	1.94
-2	28.4	36.18	68	154.4	1.88
-1	30.2	34.37	69	156.2	1.81
0	32.0	32.65	70	158.0	1.75
1	33.8	31.03	71	159.8	1.69
2	35.6	29.50	72	161.6	1.64
3	37.4	28.05	73	163.4	1.58
4	39.2	26.69	74	165.2	1.53
5	41.0	25.39	75	167.0	1.48
6	42.8	24.17	76	168.8	1.43
7	44.6	23.02	77	170.6	1.39
8	46.4	21.92	78	172.4	1.34
9	48.2	20.88	79	174.2	1.30
10	50.0	19.90	80	176.0	1.26
11	51.8	18.97	81	177.8	1.22
12	53.6	18.09	82	179.6	1.18
13	55.4	17.26	83	181.4	1.14
14	57.2	16.46	84	183.2	1.10
15	59.0	15.71	85	185.0	1.07
16	60.8	15.00	86	186.8	1.04
17	62.6	14.32	87	188.6	1.01
18	64.4	13.68	88	190.4	0.97
19	66.2	13.07	89	192.2	0.94
20	68.0	12.49	90	194.0	0.92
21	69.8	11.94	91	195.8	0.89
22	71.6	11.42	92	197.6	0.86
23	73.4	10.92	93	199.4	0.84
24	75.2	10.45	94	201.2	0.81
25	77.0	10.00	95	203.0	0.79
26	78.8	9.57	96	204.8	0.76
27	80.6	9.16	97	206.6	0.74
28	82.4	8.78	98	208.4	0.72
29	84.2	8.41	99	210.2	0.70
30	86.0	8.06	100	212.0	0.68
31	87.8	7.72	101	213.8	0.66
32	89.6	7.40	102	215.6	0.64
33	91.4	7.10	103	217.4	0.62
34	93.2	6.81	104	219.2	0.60
35	95.0	6.53	105	221.0	0.59
36	96.8	6.27	106	222.8	0.57
37	98.6	6.01	107	224.6	0.55
38	100.4	5.77	108	226.4	0.54
39	102.2	5.54	109	228.2	0.52
40	104.0	5.33	110	230.0	0.51
41	105.8	5.12	111	231.8	0.50
42	107.6	4.92	112	233.6	0.48
43	109.4	4.72	113	235.4	0.47
44	111.2	4.54	114	237.2	0.46
45	113.0	4.37	115	239.0	0.44
46	114.8	4.20	116	240.8	0.43
47	116.6	4.04	117	242.6	0.42
48	118.4	3.89	118	244.4	0.41
49	120.2	3.74	119	246.2	0.40
50	122.0	3.60	120	248.0	0.39
51	123.8	3.47	121	249.8	0.38
52	125.6	3.34	122	251.6	0.37
53	127.4	3.22	123	253.4	0.36
54	129.2	3.10			

DXM2 Thermostat Details

Thermostat Compatibility – Most heat pump and heat/cool thermostats can be used with the DXM2, as well as Comfort-Aire/Century communicating thermostats (7602-457).

Anticipation Leakage Current – Maximum leakage current for “Y1” is 50 mA and for “W” is 20mA. Triacs can be used if leakage current is less than above. Thermostats with anticipators can be used if anticipation current is less than that specified above.

Thermostat Signals -

- “Y1, Y2, W1, O” and “G” have a 1 second recognition time when being activated or being removed.
- “R” and “C” are from the transformer.
- “AL1” and “AL2” originate from the Alarm Relay.
- “A+” and “B-” are for a communicating thermostat.

Unit Starting and Operating Conditions

Operating Limits

Environment – Units are designed for indoor installation only. Never install units in areas subject to freezing or where humidity levels could cause cabinet condensation (such as unconditioned spaces subject to 100% outside air).

Power Supply – A voltage variation of +/- 10% of nameplate utilization voltage is acceptable.

Determination of operating limits is dependent primarily upon three factors: 1) return air temperature. 2) water temperature, and 3) ambient temperature. When any one of these factors is at minimum or maximum levels, the other two factors should be at normal levels to ensure proper unit operation. Extreme variations in temperature and humidity and/or corrosive water or air will adversely affect unit performance, reliability, and service life. Consult Table 8 for operating limits.

Table 8: Operating Limits

Operating Limits	TZ	
	Cooling	Heating
Air Limits		
Min. ambient air, DB	45°F [7°C]	39°F [4°C]
Rated ambient air, DB	80.6°F [27°C]	68°F [20°C]
Max. ambient air, DB	130°F [54.4°C]	85°F [29°C]
Min. entering air, DB/WB	65/45°F [18/7°C]	50°F [10°C]
Rated entering air, DB/WB	80.6/66.2°F [27/19°C]	68°F [20°C]
Max. entering air, DB/WB	100/75°F [38/24°C]	80°F [27°C]
Water Limits		
Min. entering water	*20°F [-6.7°C]	20°F [-6.7°C]
Normal entering water	50-110°F [10-43.3°C]	30-80°F [-1.1 to 26.7°C]
Max. entering water	120°F [48.9°C]	*120°F [48.9°C]
Normal Water Flow	1.5 to 3.0 gpm/ton [1.6 to 3.2 l/m per kW]	

*When unit is equipped with Internal Secondary Pump option (code 7 in position eleven of the unit model number) the minimum entering water temperature is 30°F [-1.1°C] and the maximum entering heating water is 90°F [32.2°C].

Commissioning Conditions

Consult Table 9 for the particular model. Starting conditions vary depending upon model and are based upon the following notes:

Notes:

1. Conditions in Table 9 are not normal or continuous operating conditions. Minimum/maximum limits are start-up conditions to bring the building space up to occupancy temperatures. Units are not designed to operate under these conditions on a regular basis.
2. Voltage utilization range complies with AHRI Standard 110.

Table 9: Commissioning Limits

Commissioning Limits	Cooling	Heating
Air Limits		
Min. ambient air, DB	45°F [7°C]	39°F [4°C]
Rated ambient air, DB	80.6°F [27°C]	68°F [20°C]
Max. ambient air, DB	130°F [54.4°C]	85°F [29°C]
Min. entering air, DB/WB	60/45°F [16/7°C]	50°F [10°C]
Rated entering air, DB/WB	80.6/66.2°F [27/19°C]	68°F [20°C]
Max. entering air, DB/WB	100/75°F [38/24°C]	80°F [27°C]
Water Limits		
Min. entering water	*20°F [-6.7°C]	20°F [-6.7°C]
Normal entering water	50-110°F [10-43.3°C]	30-80°F [-1.1 to 26.7°C]
Max. entering water	120°F [48.9°C]	*120°F [48.9°C]
Normal Water Flow	1.5 to 3.0 gpm/ton [1.6 to 3.2 l/m per kW]	

*When unit is equipped with Internal Secondary Pump option (code 7 in position eleven of the unit model number) the minimum entering water temperature is 30°F [-1.1°C] and the maximum entering heating water is 90°F [32.2°C].

Piping System Cleaning and Flushing

Piping System Cleaning and Flushing - Cleaning and flushing the WLHP piping system is the single most important step to ensure proper start-up and continued efficient operation of the system.

Follow the instructions below to properly clean and flush the system:

1. Ensure that electrical power to the unit is disconnected.
2. Install the system with the supply hose connected directly to the return riser valve. Use a single length of flexible hose.
3. Open all air vents. Fill the system with water. DO NOT allow system to overflow. Bleed all air from the system. Pressurize and check the system for leaks and repair as appropriate. Reheat equipped units have a manual air bleed valve at the top of the reheat coil. This valve must be used to bleed the air from the reheat coil after filling the system, for reheat to operate properly.
4. Verify that all strainers are in place (Comfort-Aire/ Century recommends a strainer with a #20 stainless steel wire mesh). Start the pumps, and systematically check each vent to ensure that all air is bled from the system.
5. Verify that make-up water is available. Adjust make-up water as required to replace the air which was bled from the system. Check and adjust the water/air level in the expansion tank.
6. Set the boiler to raise the loop temperature to approximately 86°F [30°C]. Open a drain at the lowest point in the system. Adjust the make-up water replacement rate to equal the rate of bleed.
7. Refill the system and add trisodium phosphate in a proportion of approximately one pound per 150 gallons (.8 kg per 1000 l) of water (or other equivalent approved cleaning agent). Reset the boiler to raise the loop temperature to 100°F [38°C]. Circulate the solution for a minimum of 8 to 24 hours. At the end of this period, shut off the circulating pump and drain the solution. Repeat system cleaning if desired.
8. When the cleaning process is complete, remove the short-circuited hoses. Reconnect the hoses to the proper supply, and return the connections to each of the units. Refill the system and bleed off all air.
9. Test the system pH with litmus paper. The system water should be in the range of pH 6.0 - 8.5 (see table 3). Add chemicals, as appropriate to maintain neutral pH levels.

10. When the system is successfully cleaned, flushed, refilled and bled, check the main system panels, safety cutouts and alarms. Set the controls to properly maintain loop temperatures.

Note: The manufacturer strongly recommends all piping connections, both internal and external to the unit, be pressure tested by an appropriate method prior to any finishing of the interior space or before access to all connections is limited. Test pressure may not exceed the maximum allowable pressure for the unit and all components within the water system. The manufacturer will not be responsible or liable for damages from water leaks due to inadequate or lack of a pressurized leak test, or damages caused by exceeding the maximum pressure rating during installation.

Internal Modulating Motorized Valve Positions

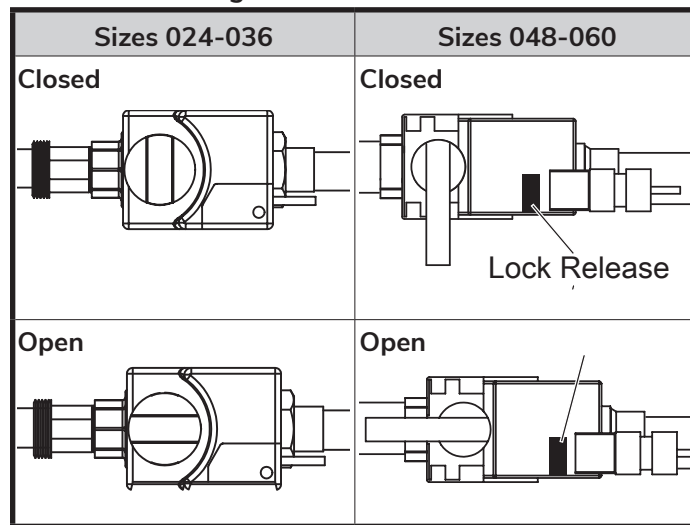

To manually open the internal modulating motorized water valve in HE026 – 049 push down on the handle to unlock it. Then rotate the handle to the open position as shown in. This fully opens the valve for flushing. Once flushing is complete, return the valve handle to its normally closed position.

To manually open the internal modulating motorized water valve in HE064 – 072, push down on the lock release button while turning the handle to the open position as shown. This fully opens the valve for flushing. Once flushing is complete, press the lock release again and return the valve handle to its normally closed position.

Unit System Checkout

WARNING!

WARNING! Polyolester Oil, commonly known as POE oil, is a synthetic oil used in many refrigeration systems including those with HFC-410A refrigerant. POE oil, if it ever comes in contact with PVC or CPVC piping, may cause failure of the PVC/CPVC. PVC/CPVC piping should never be used as supply or return water piping with water source heat pump products containing HFC-410A as system failures and property damage may result.

Unit and System Checkout

BEFORE POWERING SYSTEM, please check the following:

UNIT CHECKOUT

- Balancing/shutoff valves: Ensure that all isolation valves are open and water control valves are wired.
- Line voltage and wiring: Verify that voltage is within an acceptable range for the unit and wiring and fuses/breakers are properly sized. Verify that low voltage wiring is complete.
- Unit control transformer: Ensure that transformer has the properly selected voltage tap.
- Entering water and air: Ensure that entering water and air temperatures are within operating limits of Table 8.
- Low water temperature cutout: Verify that low water temperature cut-out on the DXM2 control is properly set.
- Unit fan: Manually rotate fan to verify free rotation and ensure that blower wheel is secured to the motor shaft. Be sure to remove any shipping supports if needed. DO NOT oil motors upon start-up. Fan motors are pre-oiled at the factory. Check unit fan speed selection and compare to design requirements.
- Condensate line: Verify that condensate line is open and properly pitched toward drain.
- Water flow balancing: Record inlet and outlet water temperatures for each heat pump upon startup. This check can eliminate nuisance trip outs and high velocity water flow that could erode heat exchangers.
- Unit air coil and filters: Ensure that filter is clean and accessible. Clean air coil of all manufacturing oils.
- Unit controls: Verify that DXM2 field selection options are properly set.

SYSTEM CHECKOUT

- System water temperature: Check water temperature for proper range and also verify heating and cooling set points for proper operation.
- System pH: Check and adjust water pH if necessary to maintain a level between 6 and 8.5. Proper pH promotes longevity of hoses and fittings (see table 3).
- System flushing: Verify that all hoses are connected end to end when flushing to ensure that debris bypasses the unit heat exchanger, water valves and other components. Water used in the system must be potable quality initially and clean of dirt, piping slag, and strong chemical cleaning agents. Verify that all air is purged from the system. Air in the system can cause poor operation or system corrosion.
- Cooling tower/boiler: Check equipment for proper setpoints and operation.
- Standby pumps: Verify that the standby pump is properly installed and in operating condition.
- System controls: Verify that system controls function and operate in the proper sequence.
- Low water temperature cutout: Verify that low water temperature cut-out controls are provided for the outdoor portion of the loop. Otherwise, operating problems may occur.
- System control center: Verify that the control center and alarm panel have appropriate setpoints and are operating as designed.
- Miscellaneous: Note any questionable aspects of the installation.

CAUTION!

CAUTION! Verify that ALL water control valves are open and allow water flow prior to engaging the compressor. Freezing of the coax or water lines can permanently damage the heat pump.

CAUTION!

CAUTION! To avoid equipment damage, DO NOT leave system filled in a building without heat during the winter unless antifreeze is added to the water loop. Heat exchangers never fully drain by themselves and will freeze unless winterized with antifreeze.

Unit Start-Up Procedure

Unit Start-up Procedure

1. Turn the thermostat fan position to "ON". Blower should start.
 2. Balance air flow at registers.
 3. Adjust all valves to their full open positions. Turn on the line power to all heat pumps.
 4. Room temperature should be within the minimum-maximum ranges of table 9. During start-up checks, loop water temperature entering the heat pump should be between 60°F [16°C] and 95°F [35°C].
 5. Two factors determine the operating limits of Comfort-Aire/Century heat pumps, (a) return air temperature, and (b) water temperature. When any one of these factors is at a minimum or maximum level, the other factor must be at normal level to ensure proper unit operation.
 - a. Adjust the unit thermostat to the warmest setting. Place the thermostat mode switch in the "COOL" position. Slowly reduce thermostat setting until the compressor activates.
 - b. Check for cool air delivery at the unit grille within a few minutes after the unit has begun to operate.

Note: Units have a five minute time delay in the control circuit that can be eliminated by pushing the test button on the DXM2 control board.
 - c. Verify that the compressor is on and that the water flow rate is correct by measuring pressure drop through the heat exchanger using the P/T plugs and comparing to table 10.
 - d. Check the elevation and cleanliness of the condensate lines. Dripping may be a sign of a blocked line. Check that the condensate trap is filled to provide a water seal.
 - e. Refer to table 12. Check the temperature of both entering and leaving water. If temperature is within range, proceed with the test. Verify correct water flow by comparing unit pressure drop across the heat exchanger versus the data in table 10. Heat of rejection (HR) can be calculated and compared to submittal data capacity pages. The formula for HR for systems with water is as follows:

$$HR \text{ (Btuh)} = TD \times GPM \times 500$$
 where TD is the temperature difference between the entering and leaving water, and GPM is the flow rate in U.S. GPM, determined by comparing the pressure drop across the heat exchanger to table 10. In S-I units, the formula is as follows: $HR \text{ (kW)} = TD \times l/s \times 4.18$.
 - f. Check air temperature drop across the air coil when compressor is operating. Air temperature drop should be between 15°F and 25°F [8°C and 14°C].
 - g. Turn thermostat to "OFF" position. A hissing noise indicates proper functioning of the reversing valve.
6. Allow five (5) minutes between tests for pressure to equalize before beginning heating test.
 - a. Adjust the thermostat to the lowest setting. Place the thermostat mode switch in the "HEAT" position.
 - b. Slowly raise the thermostat to a higher temperature until the compressor activates.
 - c. Check for warm air delivery within a few minutes after the unit has begun to operate.
 - d. Refer to table 12. Check the temperature of both entering and leaving water. If temperature is within range, proceed with the test. If temperature is outside of the operating range, check refrigerant pressures and compare to table 11. Verify correct water flow by comparing unit pressure drop across the heat exchanger versus the data in table 10. Heat of extraction (HE) can be calculated and compared to submittal data capacity pages. The formula for HE for systems with water is as follows:

$$HE \text{ (kW)} = TD \times GPM \times 500$$
 where TD is the temperature difference between the entering and leaving water, and l/s is the flow rate in U.S. GPM, determined by comparing the pressure drop across the heat exchanger to table 10. In S-I units, the formula is as follows: $HE \text{ (kW)} = TD \times l/s \times 4.18$.
 - e. Check air temperature rise across the air coil when compressor is operating. Air temperature rise should be between 20°F and 30°F [11°C and 17°C].
 - f. Check for vibration, noise, and water leaks.
7. If unit fails to operate, perform troubleshooting analysis (see troubleshooting section). If the check described fails to reveal the problem and the unit still does not operate, contact a trained service technician to ensure proper diagnosis and repair of the equipment.
8. When testing is complete, set system to maintain desired comfort level.
- Note: If performance during any mode appears abnormal, refer to the DXM2 section or troubleshooting section of this manual. To obtain maximum performance, the air coil should be cleaned before start-up. A 10% solution of dishwasher detergent and water is recommended.**

Unit Operating Conditions

Table 10: HE Coax Water Pressure Drop

Model	GPM	Pressure Drop (psi)			
		30°F*	50°F	70°F	90°F
024 Rev B	2.5	0.8	0.3	0.2	0.2
	3.0	1.2	0.6	0.5	0.5
	3.8	1.8	1.1	0.9	0.8
	4.5	2.7	1.6	1.2	1.2
	6.0	3.9	2.8	2.2	2.0
030	3.0	1.7	0.9	0.8	0.8
	3.8	2.3	1.2	1.1	1.1
	4.5	2.7	1.6	1.4	1.4
	6.0	3.8	2.4	2.2	2.1
	7.5	5.1	3.5	3.1	2.9
036 Rev B	4.0	0.6	0.1	0.1	0.1
	6.0	1.8	1.0	0.7	0.7
	6.8	2.3	1.5	1.1	1.1
	8.0	3.2	2.2	1.8	1.7
	9.0	4.0	2.9	2.4	2.3
042	3.8	1.7	1.0	0.9	0.9
	5.3	2.7	1.8	1.6	1.5
	7.5	4.5	3.1	2.8	2.6
	7.9	4.8	3.4	3.1	2.9
	10.5	7.4	5.4	4.9	4.7
048	4.5	1.4	1.1	0.9	0.8
	6.0	2.0	1.7	1.4	1.3
	6.8	2.5	2.1	1.8	1.7
	9.0	4.0	3.4	3.0	2.7
	12.0	6.5	5.5	4.9	4.5
060 Rev B	6.0	1.2	0.9	0.8	0.8
	7.5	2.1	1.7	1.5	1.4
	9.0	3.1	2.5	2.3	2.2
	12.0	5.4	4.6	4.2	3.9
	15.0	8.1	7.0	6.4	6.1

* Based on 15% methanol antifreeze solution

WARNING!

WARNING! When the disconnect switch is closed, high voltage is present in some areas of the electrical panel. Exercise caution when working with energized equipment.

CAUTION!

CAUTION! Verify that ALL water control valves are open and allow water flow prior to engaging the compressor. Freezing of the coax or water lines can permanently damage the heat pump.

CAUTION!

CAUTION! Many units are installed with a factory or field supplied manual or electric shut-off valve. **DAMAGE WILL OCCUR** if shut-off valve is closed during unit operation. A high pressure switch must be installed on the heat pump side of any field provided shut-off valves and connected to the heat pump controls in series with the built-in refrigerant circuit high pressure switch to disable compressor operation if water pressure exceeds pressure switch setting. The field installed high pressure switch shall have a cut-out pressure of 300 psig and a cut-in pressure of 250 psig.

Operating Pressure/Temperature tables include the following notes:

- Airflow is at nominal (rated) conditions;
- Entering air is based upon 70°F [21°C] DB in heating and 80/67°F [27/19°C] in cooling;
- Subcooling is based upon head pressure at compressor service port;
- Cooling air and water values can vary greatly with changes in humidity level.

Unit Operating Conditions

Table 11: HE Series Typical Unit Operating Pressures and Temperatures (60Hz – I-P Units)

024		Full Load Cooling - without HWG active						Full Load Heating - without HWG active					
Entering Water Temp °F	Water Flow GPM/ton	Suction Pressure PSIG	Discharge Pressure PSIG	Superheat	Subcooling	Water Temp Drop °F	Air Temp Drop °F DB	Suction Pressure PSIG	Discharge Pressure PSIG	Superheat	Subcooling	Water Temp Drop °F	Air Temp Rise °F DB
30*	1.5							67-77	305-325	6-11	6-11	8.0-10.0	19-25
	2.25							72-82	310-330	6-11	7-12	5.9-7.9	19-25
	3							77-87	314-334	6-11	7-12	3.8-5.8	19-25
50	1.5	127-137	244-264	9-14	13-18	20.6-22.6	19-25	98-108	346-366	9-14	8-13	11.1-13.1	26-32
	2.25	125-135	240-160	10-15	11-16	15.6-17.6	19-25	104-114	350-370	9-14	7-12	8.1-10.1	26-32
	3	124-134	237-257	11-16	8-13	11.4-13.4	19-25	111-121	355-375	9-14	6-11	5.2-7.2	27-33
70	1.5	132-142	322-342	8-13	14-19	20-22	18-24	129-139	384-404	11-16	10-15	14.4-16.4	32-38
	2.25	131-141	325-345	9-14	12-17	14.8-16.8	18-24	137-147	390-410	11-16	7-12	10.5-12.5	33-39
	3	130-140	329-349	9-14	10-15	9.6-11.6	18-24	145-155	397-417	11-16	6-11	6.5-8.5	34-40
90	1.5	140-150	410-430	6-11	15-20	19.9-21.9	17-23	162-172	421-441	14-19	8-13	17.5-19.5	39-45
	2.25	139-149	427-447	6-11	13-18	14.6-16.6	17-23	170-180	430-450	14-19	8-13	12.7-14.7	39-45
	3	138-148	444-464	7-12	11-16	9.4-11.4	17-23	178-188	440-460	14-19	8-13	9-11	41-47
110	1.5	144-154	490-510	5-10	16-21	19.8-21.8	16-22						
	2.25	143-153	500-520	5-10	14-19	14.45-16.45	16-22						
	3	143-153	513-533	5-10	13-18	9-11	16-22						

*Based on 15% Methanol antifreeze solution

030		Full Load Cooling - without HWG active						Full Load Heating - without HWG active					
Entering Water Temp °F	Water Flow GPM/ton	Suction Pressure PSIG	Discharge Pressure PSIG	Superheat	Subcooling	Water Temp Rise °F	Air Temp Drop °F DB	Suction Pressure PSIG	Discharge Pressure PSIG	Superheat	Subcooling	Water Temp Drop °F	Air Temp Rise °F DB
30*	1.5							65-75	311-331	9-14	9-14	8.0-10.0	19-24
	2.25							67-77	315-335	9-14	9-14	6.2-8.2	20-25
	3							72-82	319-339	9-14	9-14	4.3-6.3	21-26
50	1.5	122-132	240-260	10-15	11-16	19.5-21.5	18-23	95-105	353-373	11-16	10-15	10.5-12.5	26-31
	2.25	121-131	213-233	11-16	9-14	15.0-17.0	19-24	100-110	358-378	11-16	10-15	8.2-10.2	26-31
	3	121-131	186-206	11-16	7-12	10.3-12.3	19-24	105-115	362-382	12-17	10-15	5.8-7.8	27-32
70	1.5	122-132	316-336	9-14	12-17	18.8-20.8	17-22	124-134	390-410	13-18	10-15	13.5-15.5	33-38
	2.25	121-131	298-318	9-14	11-16	14.3-16.3	17-22	130-140	398-418	14-19	9-14	10.5-12.5	33-38
	3	121-131	280-300	9-14	9-14	9.8-11.8	17-22	137-147	405-425	15-20	9-14	7.5-9.5	34-39
90	1.5	133-143	438-458	8-13	14-19	17.8-19.8	15-20	156-166	430-450	16-21	8-13	16.5-18.5	37-42
	2.25	133-143	420-440	8-13	13-18	13.5-15.5	15-20	163-173	459-479	17-22	8-13	12.8-14.8	39-44
	3	132-142	401-421	8-13	11-16	9.2-11.2	15-20	170-180	448-468	18-23	8-13	9.0-11.0	40-45
110	1.5	137-147	507-527	6-11	16-21	17.2-19.2	15-20						
	2.25	136-146	490-510	7-12	14-19	13.0-15.0	15-20						
	3	135-145	473-493	7-12	13-18	8.8-10.8	15-20						

*Based on 15% Methanol antifreeze solution

036		Full Load Cooling - without HWG active						Full Load Heating - without HWG active					
Entering Water Temp °F	Water Flow GPM/ton	Suction Pressure PSIG	Discharge Pressure PSIG	Superheat	Subcooling	Water Temp Drop °F	Air Temp Drop °F DB	Suction Pressure PSIG	Discharge Pressure PSIG	Superheat	Subcooling	Water Temp Drop °F	Air Temp Rise °F DB
30*	1.5							60-70	315-335	6-11	11-16	10.0-12.0	18-23
	2.25							65-75	319-339	6-11	11-16	6.7-8.7	19-24
	3							70-80	325-345	6-11	11-16	3.4-5.4	20-25
50	1.5	123-133	232-252	11-16	12-17	19.9-21.9	19-24	88-98	353-373	9-14	14-19	13.2-15.2	24-29
	2.25	122-132	232-252	12-17	10-15	14.3-16.3	19-24	96-106	361-381	10-15	14-19	9.0-11.0	25-30
	3	121-131	232-252	13-18	7-12	9.6-11.6	19-24	105-115	370-390	10-15	14-19	4.8-6.8	26-31
70	1.5	128-138	310-330	10-15	11-16	19-21	18-23	116-126	390-410	11-16	15-20	17.0-19.0	29-34
	2.25	124-134	290-310	10-15	10-15	14.1-16.1	18-23	128-138	406-426	12-17	15-20	11.6-13.6	31-36
	3	119-129	270-290	11-16	8-13	9.2-11.2	18-23	139-149	419-439	14-19	15-20	6.1-8.1	32-37
90	1.5	135-145	420-440	7-12	11-16	18.1-20.1	17-22	148-158	436-456	14-19	15-20	20.9-22.9	35-40
	2.25	134-144	410-430	8-13	9-14	13.4-15.4	17-22	160-170	451-471	16-21	15-20	14.2-16.2	37-42
	3	132-142	390-410	8-13	8-13	8.7-10.7	17-22	173-183	466-486	17-22	15-20	7.4-9.4	39-44
110	1.5	139-149	490-510	6-11	10-15	17.8-19.8	16-21						
	2.25	138-148	480-500	6-11	9-14	13.2-15.2	16-21						
	3	137-147	470-490	6-11	8-13	8.6-10.6	16-21						

*Based on 15% Methanol antifreeze solution

Unit Operating Condition, Cont'd.

042		Full Load Cooling - without HWG active						Full Load Heating - without HWG active					
Entering Water Temp °F	Water Flow GPM/ton	Suction Pressure PSIG	Discharge Pressure PSIG	Superheat	Subcooling	Water Temp Rise °F	Air Temp Drop °F DB	Suction Pressure PSIG	Discharge Pressure PSIG	Superheat	Subcooling	Water Temp Drop °F	Air Temp Rise °F DB
30*	1.5							64-74	314-334	6-11	9-14	8.0-10.0	20-25
	2.25							67-77	317-337	6-11	9-14	6.0-8.0	20-25
	3							71-81	321-341	7-12	9-14	4.0-6.0	21-26
50	1.5	121-131	230-250	10-15	10-15	20.5-22.5	22-27	95-105	351-371	8-13	9-14	10.7-12.7	26-31
	2.25	120-130	200-240	11-16	8-13	15.2-17.2	22-27	100-110	356-376	9-14	9-14	8.1-10.1	27-32
	3	120-130	164-184	11-16	6-11	9.8-11.8	22-27	104-114	361-381	10-15	9-14	5.4-7.4	27-32
70	1.5	127-137	305-325	8-13	10-15	19.8-21.8	20-25	124-134	386-406	11-16	8-13	13.8-15.8	32-37
	2.25	125-135	290-310	9-13	9-14	14.7-16.7	21-26	131-141	390-410	12-17	8-13	10.4-12.4	33-37
	3	125-135	263-283	10-15	7-12	9.5-11.5	21-26	138-148	400-420	13-18	7-12	7.0-9.0	34-39
90	1.5	133-143	426-446	7-12	11-16	19-21	19-24	157-167	423-443	13-18	5-10	16.8-18.8	38-43
	2.25	132-142	406-426	7-12	9-14	14-16	19-24	164-174	432-452	15-20	5-10	12.7-14.7	40-45
	3	132-142	390-410	7-12	8-13	9-11	19-24	172-182	441-461	16-21	5-10	8.5-10.5	41-46
110	1.5	137-147	494-514	5-10	11-16	18-20	18-23						
	2.25	136-146	477-497	6-11	10-15	14-16	18-23						
	3	136-146	460-480	6-11	8-13	9-11	18-23						

*Based on 15% Methanol antifreeze solution

048		Full Load Cooling - without HWG active						Full Load Heating - without HWG active					
Entering Water Temp °F	Water Flow GPM/ton	Suction Pressure PSIG	Discharge Pressure PSIG	Superheat	Subcooling	Water Temp Drop °F	Air Temp Drop °F DB	Suction Pressure PSIG	Discharge Pressure PSIG	Superheat	Subcooling	Water Temp Drop °F	Air Temp Rise °F DB
30*	1.5							61-71	290-310	9-14	5-10	7.7-9.7	18-23
	2.25							64-74	293-313	9-14	5-10	5.7-7.7	18-23
	3							68-78	296-316	10-15	5-10	3.7-5.7	18-23
50	1.5	124-134	250-270	11-16	13-18	20.1-22.1	19-24	88-98	319-339	11-16	6-11	10.3-12.3	24-29
	2.25	123-133	212-232	12-17	10-15	14.8-16.8	19-24	94-104	324-344	11-16	6-11	7.8-9.8	25-30
	3	121-131	173-193	13-18	7-12	9.5-11.5	19-24	100-110	330-350	12-17	6-11	5.3-7.3	25-30
70	1.5	129-139	334-354	9-14	16-21	19.6-21.6	18-23	117-127	349-369	13-18	5-10	13.4-15.4	29-34
	2.25	128-138	309-329	10-15	13-18	14.4-16.4	18-23	125-135	357-377	14-19	5-10	10.2-12.2	30-35
	3	127-137	284-304	10-15	10-15	9.3-11.3	18-23	133-143	365-385	15-20	4-11	6.9-8.9	31-36
90	1.5	135-145	470-490	7-12	20-25	18.9-20.9	16-21	150-160	384-404	15-20	3-8	16.6-18.6	35-40
	2.25	134-144	446-466	7-12	17-22	13.8-15.8	16-21	158-168	391-411	16-21	2-7	12.6-14.6	36-41
	3	132-142	422-442	8-13	15-20	8.8-10.8	16-21	166-176	399-419	17-22	2-7	8.5-10.5	37-42
110	1.5	138-148	548-568	6-11	22-27	18.6-20.6	15-20						
	2.25	138-148	526-546	6-11	19-24	13.6-15.6	15-20						
	3	137-147	505-525	6-11	17-22	8.6-10.6	15-20						

*Based on 15% Methanol antifreeze solution

060		Full Load Cooling - without HWG active						Full Load Heating - without HWG active					
Entering Water Temp °F	Water Flow GPM/ton	Suction Pressure PSIG	Discharge Pressure PSIG	Superheat	Subcooling	Water Temp Drop °F	Air Temp Drop °F DB	Suction Pressure PSIG	Discharge Pressure PSIG	Superheat	Subcooling	Water Temp Drop °F	Air Temp Rise °F DB
30*	1.5							64-74	309-329	7-12	10-15	8.4-10.4	19-24
	2.25							68-78	313-333	7-12	10-15	6.0-8.0	20-25
	3							71-81	317-337	8-13	10-15	3.6-5.6	20-25
50	1.5	120-130	225-245	9-14	13-18	21.8-23.8	20-25	94-104	343-363	9-14	12-18	11.3-13.3	25-30
	2.25	120-130	222-242	9-14	10-15	14.7-16.7	20-25	100-110	350-270	10-15	11-16	8.2-10.2	26-31
	3	118-128	220-240	9-14	9-14	8.7-10.7	20-25	105-115	356-376	10-15	10-15	5.0-8.0	26-31
70	1.5	124-134	300-320	8-13	14-19	19.9-21.9	19-24	122-132	377-397	11-16	9-14	14.2-16.2	31-36
	2.25	124-134	278-298	8-13	11-16	14.1-16.1	19-24	130-140	386-406	12-17	8-13	10.3-12.3	31-36
	3	123-133	256-276	8-13	9-14	8.3-10.3	19-24	137-147	394-414	13-18	7-12	6.5-8.5	33-38
90	1.5	130-140	420-440	7-12	16-21	19.0-21.0	17-22	155-165	412-432	14-19	6-11	17.2-19.2	36-41
	2.25	129-139	400-420	7-12	12-17	13.4-15.4	17-22	165-175	423-443	15-20	5-10	12.6-14.6	37-42
	3	129-139	390-410	7-12	9-14	7.9-9.9	17-22	175-185	423-443	16-21	4-9	7.9-9.9	39-44
110	1.5	133-143	495-515	6-11	16-21	18.5-20.5	16-21						
	2.25	132-142	475-495	6-11	13-18	13.1-15.1	16-21						
	3	132-142	454-474	6-11	9-14	7.6-9.6	16-21						

*Based on 15% Methanol antifreeze solution

Table 12: Water Temperature Change Through Heat Exchanger

Water Flow, gpm [l/m]	Rise, Cooling	Drop, Heating
	°F, [°C]	°F, [°C]
For Closed Loop: Ground Source or Closed Loop Systems at 3 gpm per ton [3.2 l/m per kW]	9 - 12 [5 - 6.7]	4 - 8 [2.2 - 4.4]
For Open Loop: Ground Water Systems at 1.5 gpm per ton [1.6 l/m per kW]	20 - 26 [11.1 - 14.4]	10 - 17 [5.6 - 9.4]

Preventive Maintenance

Water Coil Maintenance - (Direct ground water applications only) If the system is installed in an area with a known high mineral content (125 P.P.M. or greater) in the water, it is best to establish a periodic maintenance schedule with the owner so the coil can be checked regularly. Consult the well water applications section of this manual for a more detailed water coil material selection. Should periodic coil cleaning be necessary, use standard coil cleaning procedures, which are compatible with the heat exchanger material and copper water lines. Generally, the more water flowing through the unit, the less chance for scaling. Therefore, 1.5 gpm per ton [1.6 l/m per kW] is recommended as a minimum flow. Minimum flow rate for entering water temperatures below 50°F [10°C] is 2.0 gpm per ton [2.2 l/m per kW].

Water Coil Maintenance - (All other water loop applications) Generally water coil maintenance is not needed for closed loop systems. However, if the piping is known to have high dirt or debris content, it is best to establish a periodic maintenance schedule with the owner so the water coil can be checked regularly. Dirty installations are typically the result of deterioration of iron or galvanized piping or components in the system. Open cooling towers requiring heavy chemical treatment and mineral buildup through water use can also contribute to higher maintenance. Should periodic coil cleaning be necessary, use standard coil cleaning procedures, which are compatible with both the heat exchanger material and copper water lines. Generally, the more water flowing through the unit, the less chance for scaling. However, flow rates over 3 gpm per ton (3.9 l/m per kW) can produce water (or debris) velocities that can erode the heat exchanger wall and ultimately produce leaks.

Hot Water Generator Coils - See water coil maintenance for ground water units. If the potable water is hard or not chemically softened, the high temperatures of the desuperheater will tend to scale even quicker than the water coil and may need more frequent inspections. In areas with extremely hard water, a HWG is not recommended.

Filters - Filters must be clean to obtain maximum performance. Filters should be inspected every month under normal operating conditions and be replaced when necessary. Units should never be operated without a filter.

Washable, high efficiency, electrostatic filters, when dirty, can exhibit a very high pressure drop for the fan motor and reduce air flow, resulting in poor performance. It is especially important to provide consistent washing of

these filters (in the opposite direction of the normal air flow) once per month using a high pressure wash similar to those found at self-serve car washes.

Condensate Drain - In areas where airborne bacteria may produce a "slimy" substance in the drain pan, it may be necessary to treat the drain pan chemically with an algaecide approximately every three months to minimize the problem. The condensate pan may also need to be cleaned periodically to ensure indoor air quality. The condensate drain can pick up lint and dirt, especially with dirty filters. Inspect the drain twice a year to avoid the possibility of plugging and eventual overflow.

Compressor - Conduct annual amperage checks to ensure that amp draw is no more than 10% greater than indicated on the serial plate data.

Fan Motors - All units have lubricated fan motors. Fan motors should never be lubricated unless obvious, dry operation is suspected. Periodic maintenance oiling is not recommended, as it will result in dirt accumulating in the excess oil and cause eventual motor failure. Conduct annual dry operation check and amperage check to ensure amp draw is no more than 10% greater than indicated on serial plate data.

Air Coil - The air coil must be clean to obtain maximum performance. Check once a year under normal operating conditions and, if dirty, brush or vacuum clean. Care must be taken not to damage the aluminum fins while cleaning. When the heat pump has experienced less than 100 operational hours and the coil has not had sufficient time to be "seasoned", it is necessary to clean the coil with a mild surfactant such as Calgon to remove the oils left by manufacturing processes and enable the condensate to properly "sheet" off of the coil.

CAUTION: Fin edges are sharp.

Cabinet - Do not allow water to stay in contact with the cabinet for long periods of time to prevent corrosion of the cabinet sheet metal. Generally, vertical cabinets are set up from the floor a few inches [7 - 8 cm] to prevent water from entering the cabinet. The cabinet can be cleaned using a mild detergent.

Refrigerant System - To maintain sealed circuit integrity, do not install service gauges unless unit operation appears abnormal. Reference the operating charts for pressures and temperatures. Verify that air and water flow rates are at proper levels before servicing the refrigerant circuit.

Troubleshooting

General

If operational difficulties are encountered, perform the preliminary checks below before referring to the troubleshooting charts.

- Verify that the unit is receiving electrical supply power.
- Make sure the fuses in the fused disconnect switches are intact.

After completing the preliminary checks described above, inspect for other obvious problems such as leaking connections, broken or disconnected wires, etc. If everything appears to be in order, but the unit still fails to operate properly, refer to the “DXM2 Troubleshooting Process Flowchart” or “Functional Troubleshooting Chart.”

DXM2 Board

DXM2 board troubleshooting in general is best summarized as verifying inputs and outputs. After inputs and outputs have been verified, board operation is confirmed and the problem must be elsewhere. Below are some general guidelines for troubleshooting the DXM2 control.

Field Inputs

Conventional thermostat inputs are 24VAC from the thermostat and can be verified using a voltmeter between C and Y1, Y2, W, O, G. 24VAC will be present at the terminal (for example, between “Y1” and “C”) if the thermostat is sending an input to the DXM2 board.

Proper communications with a thermostat can be verified using the Fault LED on the DXM2. If the control is NOT in the Test mode and is NOT currently locked out or in a retry delay, the Fault LED on the DXM2 will flash very slowly (1 second on, 5 seconds off), if the DXM2 is properly communicating with the thermostat.

Sensor Inputs

All sensor inputs are ‘paired wires’ connecting each component to the board. Therefore, continuity on pressure switches, for example can be checked at the board connector. The thermistor resistance should be measured with the connector removed so that only the impedance of the thermistor is measured. If desired, this reading can be compared to the thermistor resistance chart shown in Table 7. An ice bath can be used to check the calibration of the thermistor.

Outputs

The compressor and reversing valve relays are 24VAC and can be verified using a voltmeter. For units with ECM blower motors, the DXM2 controls the motor using serial communications, and troubleshooting should be done with a communicating thermostat or diagnostic tool. The alarm relay can either be 24VAC as shipped or dry contacts for use with DDC controls by clipping the JW1 jumper. Electric heat outputs are 24VDC “ground sinking” and require a voltmeter set for DC to verify operation. The terminal marked “24VDC” is the 24VDC supply to the electric heat board; terminal “EH1” is stage 1 electric heat; terminal “EH2” is stage 2 electric heat. When electric heat is energized (thermostat is sending a “W” input to the DXM2 controller), there will be 24VDC between terminal “24VDC” and “EH1” (stage 1 electric heat) and/or “EH2” (stage 2 electric heat). A reading of 0VDC between “24VDC” and “EH1” or “EH2” will indicate that the DXM2 board is NOT sending an output signal to the electric heat board.

Test Mode

Test mode can be entered for 20 minutes by pressing the Test pushbutton. The DXM2 board will automatically exit test mode after 20 minutes.

WARNING!

WARNING! HAZARDOUS VOLTAGE! DISCONNECT ALL ELECTRIC POWER INCLUDING REMOTE DISCONNECTS BEFORE SERVICING.

Failure to disconnect power before servicing can cause severe personal injury or death.

Troubleshooting, Cont'd.

Advanced Diagnostics

If a communicating thermostat or diagnostic tool (7602-444) is connected to the DXM2, additional diagnostic information and troubleshooting capabilities are available. The current status of all DXM2 inputs can be verified, including the current temperature readings of all temperature inputs. With a communicating thermostat the current status of the inputs can be accessed from the Service Information menu. In the manual operating mode, most DXM2 outputs can be directly controlled for system troubleshooting. With a communicating thermostat the manual operating mode can be accessed from the Installer menu. For more detailed information on the advanced diagnostics of the DXM2, see the DXM2 Application, Operation and Maintenance (AOM) manual (part #97B0003N15).

DXM2 Troubleshooting Process Flowchart/Functional Troubleshooting Chart

The “DXM2 Functional Troubleshooting Process Flowchart” is a quick overview of how to start diagnosing a suspected problem, using the fault recognition features of the DXM2 board. The “Functional Troubleshooting Chart” on the following page is a more comprehensive method for identifying a number of malfunctions that may occur, and is not limited to just the DXM2 controls. Within the chart are five columns:

- The “Fault” column describes the symptoms.
- Columns 2 and 3 identify in which mode the fault is likely to occur, heating or cooling.
- The “Possible Cause column” identifies the most likely sources of the problem.
- The “Solution” column describes what should be done to correct the problem.

DXM2 Process Flow Chart

⚠ WARNING! ⚠

WARNING! HAZARDOUS VOLTAGE! DISCONNECT ALL ELECTRIC POWER INCLUDING REMOTE DISCONNECTS BEFORE SERVICING.
Failure to disconnect power before servicing can cause severe personal injury or death.

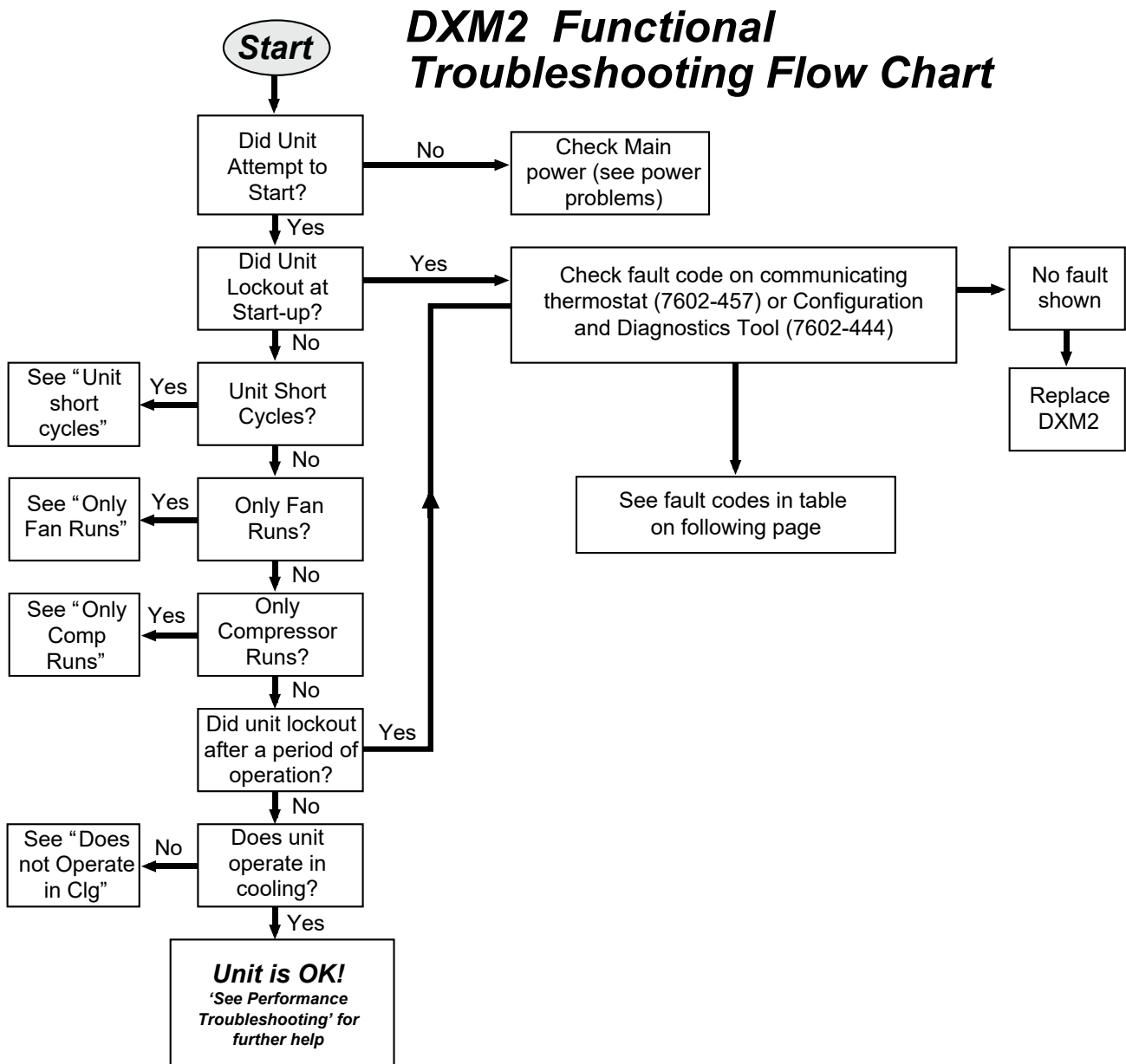

Functional Troubleshooting

Fault	Htg	Clg	Possible Cause	Solution
Main power problems	X	X	Green Status LED Off	Check line voltage circuit breaker and disconnect.
				Check for line voltage between L1 and L2 on the contactor.
				Check for 24VAC between R and C on CXM/DXM'
HP Fault Code 2 High Pressure		X	Reduced or no water flow in cooling	Check pump operation or valve operation/setting. Check water flow adjust to proper flow rate.
		X	Water Temperature out of range in cooling	Bring water temp within design parameters.
	X		Reduced or no air flow in heating	Check for dirty air filter and clean or replace.
				Check fan motor operation and airflow restrictions.
				Dirty Air Coil- construction dust etc. Too high of external static. Check static vs blower table.
	X		Air temperature out of range in heating	Bring return air temp within design parameters.
	X	X	Overcharged with refrigerant	Check superheat/subcooling vs typical operating condition table.
X	X	Bad HP Switch	Check switch continuity and operation. Replace.	
LP/LOC Fault Code 3 Low Pressure / Loss of Charge	X	X	Insufficient charge	Check for refrigerant leaks
	X		Compressor pump down at start-up	Check charge and start-up water flow.
LT1 Fault Code 4 Water coil low temperature limit	X		Reduced or no water flow in heating	Check pump operation or water valve operation/setting. Plugged strainer or filter. Clean or replace.. Check water flow adjust to proper flow rate.
			Inadequate antifreeze level	Check antifreeze density with hydrometer.
	X		Improper temperature limit setting (30°F vs 10°F [-1°C vs -2°C])	Clip JW3 jumper for antifreeze (10°F [-12°C]) use.
	X		Water Temperature out of range	Bring water temp within design parameters.
	X	X	Bad thermistor	Check temp and impedance correlation per chart
LT2 Fault Code 5 Air coil low temperature limit		X	Reduced or no air flow in cooling	Check for dirty air filter and clean or replace. Check fan motor operation and airflow restrictions. Too high of external static. Check static vs blower table.
		X	Air Temperature out of range	Too much cold vent air? Bring entering air temp within design parameters.
		X	Improper temperature limit setting (30°F vs 10°F [-1°C vs -12°C])	Normal airside applications will require 30°F [-1°C] only.
	X	X	Bad thermistor	Check temp and impedance correlation per chart.
Condensate Fault Code 6	X	X	Blocked drain	Check for blockage and clean drain.
	X	X	Improper trap	Check trap dimensions and location ahead of vent. Check for piping slope away from unit.
		X	Poor drainage	Check slope of unit toward outlet. Poor venting. Check vent location.
		X	Moisture on sensor	Check for moisture shorting to air coil.
	X	X	Plugged air filter	Replace air filter.
	x	X	Restricted Return Air Flow	Find and eliminate restriction. Increase return duct and/or grille size.
	Over/Under Voltage Code 7 (Auto resetting)	X	X	Under Voltage
Check power supply wire size.				
Check compressor starting. Need hard start kit?				
X		X	Over Voltage	Check 24VAC and unit transformer tap for correct power supply voltage. Check power supply voltage and 24VAC before and during operation. Check 24VAC and unit transformer tap for correct power supply voltage.
Unit Performance Sentinel Code 8	X		Heating mode LT2>125°F [52°C]	Check for poor air flow or overcharged unit.
		X	Cooling Mode LT1>125°F [52°C] OR LT2< 40°F [4°C])	Check for poor water flow, or air flow.
Swapped Thermistor Code 9	X	X	LT1 and LT2 swapped	Reverse position of thermistors
ECM Fault - Code 10	X	X	Blower does not operate	Check blower line voltage
				Check blower low voltage wiring
			Blower operating with incorrect airflow	Wrong unit size selection
				Wrong unit family selection
				Wrong motor size
			Incorrect blower selection	

Functional Troubleshooting, Cont'd.

Fault	Htg	Clg	Possible Cause	Solution
Low Air Coil Pressure Fault (ClimaDry) Code 11		X	Reduced or no air flow in cooling or ClimaDry	Check for dirty air filter and clean or replace Check fan motor operation and airflow restrictions Too high of external static - check static vs blower table
			Air temperature out of range	Too much cold vent air - bring entering air temp within design parameters
			Bad pressure switch	Check switch continuity and operation - replace
Low Air Coil Temperature Fault - (ClimaDry) Code 12		X	Reduced airflow in cooling, ClimaDry, or constant fan	Check for dirty air filter and clean or replace Check fan motor operation and airflow restrictions Too high of external static - check static vs blower table
			Air temperature out of range	Too much cold vent air - bring entering air temp within design parameters
			Bad thermistor	Check temp and impedance correlation per chart
ESD - ERV Fault (DXM Only) Green Status LED Code 3	X	X	ERV unit has fault (Rooftop units only)	Troubleshoot ERV unit fault
No Fault Code Shown	X	X	No compressor operation	See 'Only Fan Operates'
			Compressor overload	Check and replace if necessary
			Control board	Reset power and check operation
Unit Short Cycles	X	X	Dirty air filter	Check and clean air filter
			Unit in 'Test Mode'	Reset power or wait 20 minutes for auto exit
			Unit selection	Unit may be oversized for space - check sizing for actual load of space
			Compressor overload	Check and replace if necessary
Only Fan Runs	X	X	Thermostat position	Ensure thermostat set for heating or cooling operation
			Unit locked out	Check for lockout codes - reset power
			Compressor overload	Check compressor overload - replace if necessary
			Thermostat wiring	Check thermostat wiring at DXM2 - put in Test Mode and jumper Y1 and R to give call for compressor

Performance Troubleshooting

Symptom	Htg	Clg	Possible Cause	Solution
Insufficient Capacity/ Not Cooling or Heating Properly	X	X	Dirty filter	Replace or clean
	X		Reduced or no air flow in heating	Check for dirty air filter and clean or replace
				Check fan motor operation and airflow restrictions
				Too high of external static - check static vs blower table
		X	Reduced or no air flow in cooling	Check for dirty air filter and clean or replace
				Check fan motor operation and airflow restrictions
				Too high of external static - check static vs blower table
	X	X	Leaky duct work	Check supply and return air temperatures at the unit and at distant duct registers if significantly different, duct leaks are present
	X	X	Low refrigerant charge	Check superheat and subcooling per chart
	X	X	Restricted metering device	Check superheat and subcooling per chart - replace
	X	Defective reversing valve	Perform RV touch test	
X	X	Thermostat improperly located	Check location and for air drafts behind stat	
X	X	Unit undersized	Recheck loads & sizing check sensible cooling load and heat pump capacity	
X	X	Scaling in water heat exchanger	Perform Scaling check and clean if necessary	
X	X	Inlet water too hot or cold	Check load, loop sizing, loop backfill, ground moisture	
High Head Pressure	X		Reduced or no air flow in heating	Check for dirty air filter and clean or replace
				Check fan motor operation and airflow restrictions
				Too high of external static - check static vs blower table
		X	Reduced or no water flow in cooling	Check pump operation or valve operation/setting
		X	Inlet water too hot	Check water flow adjust to proper flow rate
	X		Air temperature out of range in heating	Check load, loop sizing, loop backfill, ground moisture
		X	Scaling in water heat exchanger	Bring return air temp within design parameters
X	X	Unit over charged	Perform Scaling check and clean if necessary	
X	X	Non-condensables in system	Check superheat and subcooling - reweigh in charge	
X	X	Restricted metering device	Vacuum system and reweigh in charge	
Low Suction Pressure	X		Reduced water flow in heating	Check superheat and subcooling per chart - replace
				Check pump operation or water valve operation/setting
				Plugged strainer or filter - clean or replace
		X	Water temperature out of range	Check water flow adjust to proper flow rate
		X	Reduced air flow in cooling	Bring water temp within design parameters
	X	Air temperature out of range	Check for dirty air filter and clean or replace	
Low Discharge Air Temperature in Heating	X		Too high of air flow	Check fan motor operation and airflow restrictions
				Too much cold vent air - bring entering air temp within design parameters
	X	Insufficient charge	Check for refrigerant leaks	
Low Discharge Air Temperature in Heating	X		Too high of air flow	Check fan motor speed selection and airflow chart
				Poor performance

Performance Troubleshooting, Cont'd.

Symptom	Htg	Clg	Possible Cause	Solution
High Humidity		X	Too high of air flow	Check fan motor speed selection and airflow chart
		X	Unit oversized	Recheck loads & sizing check sensible cooling load and heat pump capacity
Only Compressor Runs	X	X	Thermostat wiring	Check G wiring at heat pump. Jumper G and R for fan operation.
	X	X	Fan motor relay	Jumper G and R for fan operation. Check for Line voltage across blower relay contacts. Check fan power enable relay operation (if present)
	X	X	Fan motor	Check for line voltage at motor. Check capacitor
	X	X	Thermostat wiring	Check thermostat wiring at or DXM2. Put in Test Mode and then jumper Y1 and W1 to R to give call for fan, compressor and electric heat.
Unit Doesn't Operate in Cooling		X	Reversing Valve	Set for cooling demand and check 24VAC on RV coil. If RV is stuck, run high pressure up by reducing water flow and while operating engage and disengage RV coil voltage to push valve.
		X	Thermostat setup	For DXM2 check for "O" RV setup not "B".
		X	Thermostat wiring	Check O wiring at heat pump. DXM2 requires call for compressor to get RV coil "Click."
Modulating Valve Troubleshooting	X	X	Improper output setting	Verify the AO-2 jumper is in the 0-10V position
			No valve output signal	Check DC voltage between AO2 and GND. Should be 0 when valve is off and between 3.3v and 10v when valve is on.
			No valve operation	Check voltage to the valve Replace valve if voltage and control signals are present at the valve and it does not operate

Start-Up Log Sheet

Installer: Complete unit and system checkout and follow unit start-up procedures in the IOM. Use this form to record unit information, temperatures and pressures during start-up. Keep this form for future reference.

Job Name: _____ **Street Address:** _____

Model Number: _____ **Serial Number:** _____

Unit Location in Building: _____

Date: _____ **Sales Order No:** _____

In order to minimize troubleshooting and costly system failures, complete the following checks and data entries before the system is put into full operation.

Fan Motor: CFM Settings (ECM) _____

Temperatures: F or C

Antifreeze: _____ %

Pressures: PSIG or kPa

Type _____

Cooling Mode

Heating Mode

Entering Fluid Temperature			
Leaving Fluid Temperature			
Temperature Differential			
Return-Air Temperature	DB	WB	DB
Supply-Air Temperature	DB	WB	DB
Temperature Differential			
Water Coil Heat Exchanger (Water Pressure IN)			
Water Coil Heat Exchanger (Water Pressure OUT)			
Pressure Differential			
Water Flow GPM			
Compressor			
Amps			
Volts			
Discharge Line Temperature			
Motor			
Amps			
Volts			

Allow unit to run 15 minutes in each mode before taking data.

Note: Never connect refrigerant gauges during startup procedures. Conduct water-side analysis using P/T ports to determine water flow and temperature difference. If water-side analysis shows poor performance, refrigerant troubleshooting may be required. Connect refrigerant gauges as a last resort.

Functional Troubleshooting

HEATING CYCLE ANALYSIS -

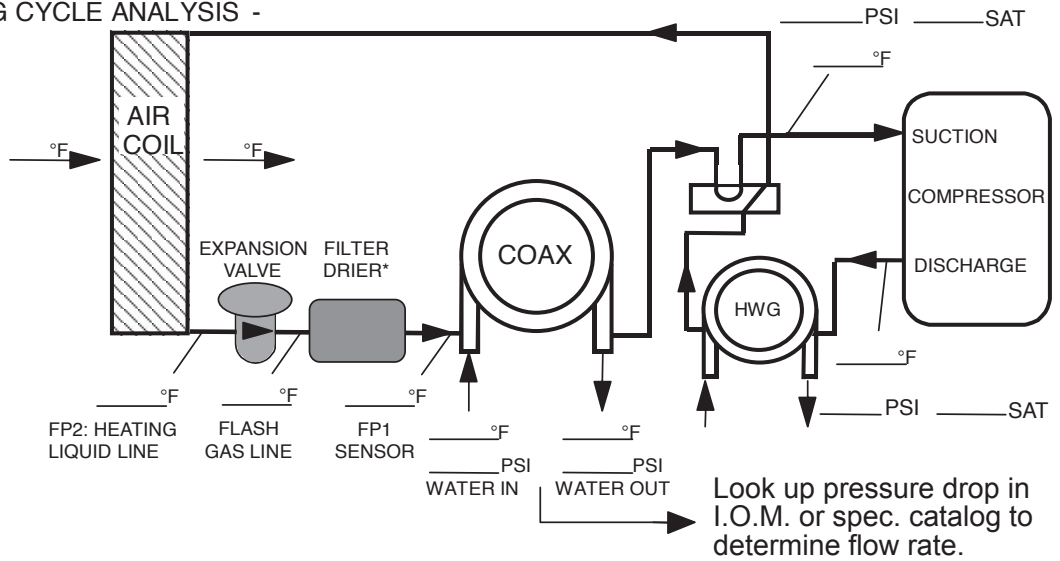

COOLING CYCLE ANALYSIS -

Refrigerant Type:

HFC-410A

Voltage: _____

Comp Amps: _____

Total Amps: _____

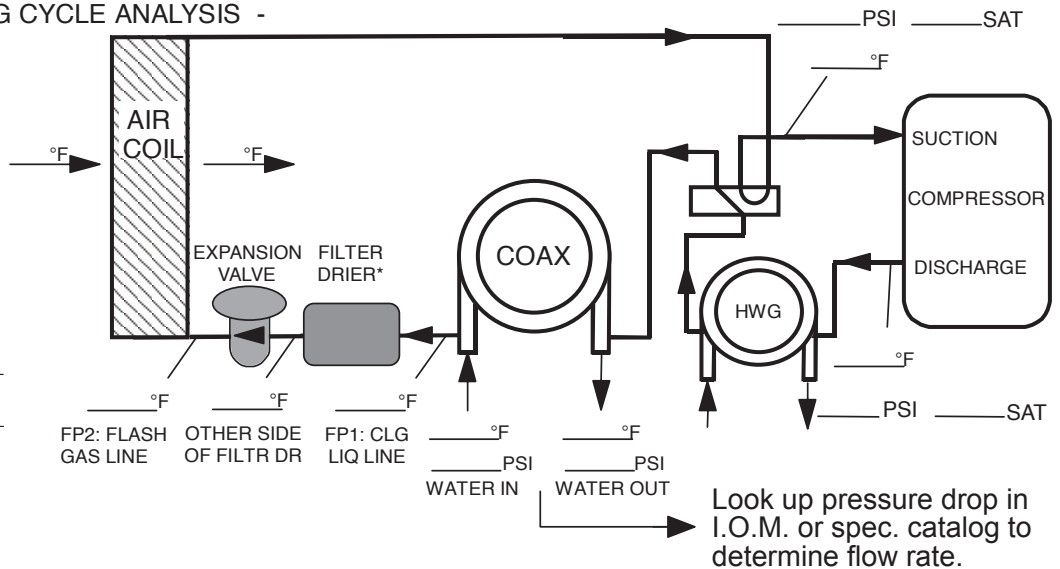

Heat of Extraction (Absorption) or Heat of Rejection =

$$\text{_____ flow rate (gpm)} \times \text{_____ temp.diff. (deg. F)} \times \text{_____ fluid factor}^\dagger = \text{_____ (Btu/hr)}$$

Superheat = Suction temperature - suction saturation temp. = _____ (deg F)

Subcooling = Discharge saturation temp. - liquid line temp. = _____ (deg F)

† Use 500 for water, 485 for antifreeze.

Rev. 12/08

Note: Never connect refrigerant gauges during startup procedures. Conduct water-side analysis using P/T ports to determine water flow and temperature difference. If water-side analysis shows poor performance, refrigerant troubleshooting may be required. Connect refrigerant gauges as a last resort.

Notes:

Notes:

Notes:



LIMITED EXPRESS WARRANTY

Congratulations on purchasing your new HVAC equipment. It's been designed for long life and reliable service, and is backed by one of the strongest warranties in the industry. Your unit automatically qualifies for the warranty coverage listed below, providing you keep your proof of purchase (receipt) for the equipment and meet the warranty conditions.

LIMITED TEN (10) YEAR EXPRESS WARRANTY

MARS warrants all parts of the HEH/HEV residential geothermal heat pump including the compressor to be free from defects in workmanship and materials for normal use and maintenance for ten (10) years from the date of purchase by the original consumer for the original installation. This Express Limited Warranty applies only when the geothermal heat pump is installed as a complete matched system, and only when the system is installed per MARS installation instructions and in accordance with all local, state and national codes for normal use.

LIMITED FIVE (5) YEAR LABOR ALLOWANCE

Labor is allowed for warranty service for a period of five (5) years from the date of purchase when the unit is properly registered and commissioned according to the start-up procedure specified in the Installation/Operation Manual, and when the Geothermal Start-Up Certification Form is completed and submitted to MARS.

EXCEPTIONS

The Limited Express Warranty does not cover normal maintenance—MARS recommends that regular inspection/maintenance be performed at least once a season and proof of maintenance be kept. Additionally, labor charges, transportation charges for replacement parts, replacement of refrigerant or filters, any other service calls/repairs are not covered by this Limited Warranty. It also does not cover any portion or component of the system that is not supplied by MARS, regardless of the cause of failure of such portion or component.

CONDITIONS FOR WARRANTY COVERAGE

- Unit must be operated according to MARS operating instructions included with the unit and cannot have been subjected to accident, alteration, improper repair, neglect or misuse, or an act of God (such as a flood)
- Installation was done by a trained, licensed or otherwise qualified HVAC dealer/contractor
- Performance cannot be impaired by use of any product not authorized by MARS, or by any adjustments or adaptations to components
- Serial numbers and/or rating plate have not been altered or removed
- Damage has not been a result of inadequate wiring or voltage conditions, use during brown-out conditions, or circuit interruptions
- Air flow around any section of the unit has not been restricted
- Unit remains in the original installation
- Unit was not purchased over the internet

DURATION OF WARRANTY & REGISTRATION

The warranty begins on the date of purchase by the original consumer. The consumer must retain a receipted bill of sale as proof of warranty period. Without this proof, the express warranty begins on the date of shipment from the factory.

REMEDY PROVIDED BY THE LIMITED EXPRESS WARRANTY

The sole remedy under the Limited Warranty is replacement of the defective part. If replacement parts are required within the period of this warranty, MARS replacement parts shall be used; any warranty on the replacement part(s) shall not affect the applicable original unit warranty. Ready access to the unit for service is the owner's responsibility. Labor to diagnose and replace the defective part is not covered by this Limited Express Warranty. If for any reason the replacement part/product is no longer available during the warranty period, MARS shall have the right to allow a credit in the amount of the current suggested retail price of the part/product instead of providing repair or replacement.

LIMITATION OF LIABILITY

1. There are no other express or implied warranties. MARS makes no warranty of merchantability. We do not warrant that the unit is suitable for any particular purpose or can be used in buildings or rooms of any particular size or condition except as specifically provided in this document. There are no other warranties, express or implied, which extend beyond the description in this document.
2. All warranties implied by law are limited in duration to the seven-year term of the parts warranty. Your exclusive remedy is limited to the replacement of defective parts. **We will not be liable for any consequential or incidental damages caused by any defect in this unit.**
3. This warranty gives you specific legal rights and you may also have other rights which vary from state to state. Some states do not allow limitation on how long an implied warranty lasts or do not allow the exclusion or limitation of incidental or consequential damages, so the above limitations or exclusions may not apply to you.
4. No warranties are made for units sold outside the continental United States and Canada. Your distributor or final seller may provide a warranty on units sold outside these areas.
5. MARS will not be liable for damages if our performance regarding warranty resolution is delayed by events beyond our control including accident, alteration, abuse, war, government restrictions, strikes, fire, flood, or other acts of God.

HOW TO OBTAIN WARRANTY SERVICE OR PARTS

If you have a warranty claim, notify your installer promptly. If the installer does not remedy your claim, write to MARS, 1900 Wellworth Ave., Jackson MI 49203. Enclose a report of inspection by your installer or service person. Include model number, serial number, and date of purchase.

Owner responsibilities are set forth in the instruction manual—read it carefully.

Please visit www.marsdelivers.com to register your new product



KEEP THIS INFORMATION AS A RECORD OF YOUR PURCHASE

GEOHERMAL HEAT PUMP

INSTALLATION

Model Number _____

Installer Name _____

Serial Number _____

Phone Number/Contact Information _____

Date of Purchase _____

Date Installation Completed _____

- Component of new HVAC system Replacement heat pump only

Remember to retain your bill of sale as proof of warranty period.

Revision History

Date:	Item:	Action:
7/8/21	All	Added Polymer drain pan
1/23/19	Pages 15,16, 25	High Head Variable Pump update
11/7/18	Decoder	Updated warter circuit options
10/26/18	Decoder	Added disconnect to control
07/25/17	Page 7	Update hanger and mounting instructions
10/7/16	Page 7	Text Update
06/22/16	Cover	Updated Unit Photo
04/15/16	Text	Updated
06/09/15	Decoder - Page 3; Text - Page 24 & 25	Updated
05/12/15	Decoder - Page 3	Changed to Rev C
12/17/14	Table - Page 6	Updated
06/10/14	Pages 8, 11, 12, 15, 20, 22, 25, 32, 33, 34	Misc. edits
03/24/14	Table 10	Updated PD 024, 036, 060
10/08/13	Figure 7b	Updated
10/07/13	Figure 10a: Vertical Condensate Drain	Updated
01/21/13	vFlow Tables	Updated GPM, WPD
11/09/12	POE Oil Warning	Added
10/29/12	Unit Operating Conditions Water Quality Table Condensate Drain Connection Nominal Resistance at Various Temp Table	Updated
06/05/12	First Published	

Due to ongoing product improvements, specifications and dimensions are subject to change and correction without notice or incurring obligations. Determining the application and suitability for use of any product is the responsibility of the installer. Additionally, the installer is responsible for verifying dimensional data on the actual product prior to beginning any installation preparations.

Incentive and rebate programs have precise requirements as to product performance and certification. All products meet applicable regulations in effect on date of manufacture; however, certifications are not necessarily granted for the life of a product. Therefore, it is the responsibility of the applicant to determine whether a specific model qualifies for these incentive/rebate programs.



1900 Wellworth Ave., Jackson, MI 49203 • Ph. 517-787-2100 • www.heatcontroller.com



97B0130N01