Comfort-Cire®

Century®

Design Guide

HNW Series

Table of Contents

Series Features.....	3	Electrical Data.....	14
Unit Model Key.....	5	HNW 036 & 060 Electrical Wiring Diagram.....	16
AHRI/ISO/ASHRAE/ANSI 13256-2 Performance.....	6	HNW 120 Electrical Wiring Diagram	17
Performance Data Selection Notes.....	7	Warranty Information	18
Performance Data	8	Accessories & Options	20
Physical Data	14	Revision History	20
HNW 036, 060 & 120 Dimensions.....	15		



Water-To-Water (HNW) Series Features

The Water-To-Water (HNW) Series

The HNW water to water series offers a wide range of units for most any installation with an extended range refrigerant circuit, capable of ground water (geothermal) applications. As Comfort-Aire/Century's most adaptable EarthPure® HFC-410A refrigerant units, the HNW Series can be used for radiant floor heating, snow/ice melt, chilled water for fan coils, hot water generation (with hot water generator option), hot/chilled water for make-up air, and many other types of HVAC applications.

Available in sizes 036 [8.7 kW], 060 [13.5 kW] and 120 [26.9 kW] the HNW Series offers a wide range of units for open loop (ground water) applications. Standard features are many. Coaxial heat exchangers, refrigerant suction lines and all water lines are fully insulated to eliminate condensation problems in low temperature applications. Microprocessor controls, galvanized steel cabinet, powder coat paint, insulated cupro-nickel source coaxial heat exchanger, insulated copper load coaxial heat exchanger, stainless steel front access panels and TXV refrigerant metering device are just some of the features of the flexible HNW Series.

Comfort-Aire/Century's exclusive dual level compressor isolation mounting system makes the HNW Series the quietest water-to-water unit on the market. Compressors are mounted on vibration isolation grommets to a heavy gauge mounting plate, which is then isolated from the cabinet base with rubber grommets for maximized vibration/sound attenuation.

The HNW Series water-to-water heat pumps are designed to meet the challenges of today's HVAC demands with a high efficiency, high value solution.

Application Flexibility

- Three Capacities 036 [8.7 kW], 060 [13.5 kW], & 120 [26.9 kW].
- Copeland scroll compressors.
- Dual refrigeration circuits on size 120.
- Galvanized steel construction with epoxy powder coat paint.
- Insulated compressor compartment.
- TXV metering device.
- Microprocessor controls standard.
- 1" swivel-type water connections for models 036 & 060.
- Flush securely-mounted corner post water connections (no backup wrench required) for model 120.
- Compressor "run" and "fault" lights on the front of the cabinet.
- Seven Safeties Standard.
- Intended for open loop (geothermal) applications only.

Service & Installation Advantages

- Three Removable access panels.
- Low profile control box grants easy access to all internal components.

- Factory installed liquid line filter/drier.
- EarthPure® HFC-410A zero ozone depletion refrigerant.
- Brass swivel-type water connections for quick connection and elimination of wrenches or sealants during installation. (036,060 models)
- Bi-directional thermal expansion valve.
- CXM control features status lights with memory for easy diagnostics.
- Circuit breaker protected 75VA control transformer.
- High and low pressure service ports on refrigerant circuit.
- Accurate refrigerant sensing low-temperature protection.
- Solid state CXM control features: Anti-short cycle, high & low pressure, loss of charge protection, LED fault, and status indication with memory for easy diagnostics.

Factory Quality & Certifications

- All units are built and factory run tested on our Integrated Process Control Assembly System (IPCS). The IPCS is a unique state-of-the-art manufacturing system that is designed to assure quality of the highest standards of any manufacturer in the water-source industry. Our IPCS system:
 - Verifies that the correct components are being assembled.
 - Automatically performs special leak tests on all joints.
 - Conducts pressure tests.
 - Performs detailed run test.
 - Automatically disables packaging for a "failed" unit.
 - Creates computer database for future service analysis and diagnostics from run test results.
- All refrigerant brazing is done in a nitrogen atmosphere.
- All units are deep evacuated to less than 240 microns prior to refrigerant charging.
- All joints are both helium and halogen leak tested to insure annual leak rate of less than 1/4 ounce.
- AHRI/ASHRAE/ANSI/ISO 13256-2 certified.
- ETL listed.
- US EPA "Energy Star" certified for GWHP applications.

Options & Accessories

- Cupro-nickel load heat exchanger.
- Hot water generator with internal pump.
- Geothermal pumping modules

Water-To-Water (HNW) Series Features

- 1 Copeland™ High Efficiency Scroll Compressor
- 2 Optional Hot Water Generator With Internal Pump
- 3 Fully Insulated Water and Refrigerant Lines
- 4 Fully Insulated Compressor Section
- 5 Powder Coated Steel Cabinet with Stainless Steel Access Panels For Long Life
- 6 System Operating LED Lights
- 7 Unit Performance Sentinel: Automatic Alert System Lets You Know If The System Is Not Running At Peak Performance
- 8 Dual Level Compressor Isolation Mounting for Ultra Quiet Operation
- 9 Multiple Removable Access Panels for Service
- 10 Coaxial heat exchangers

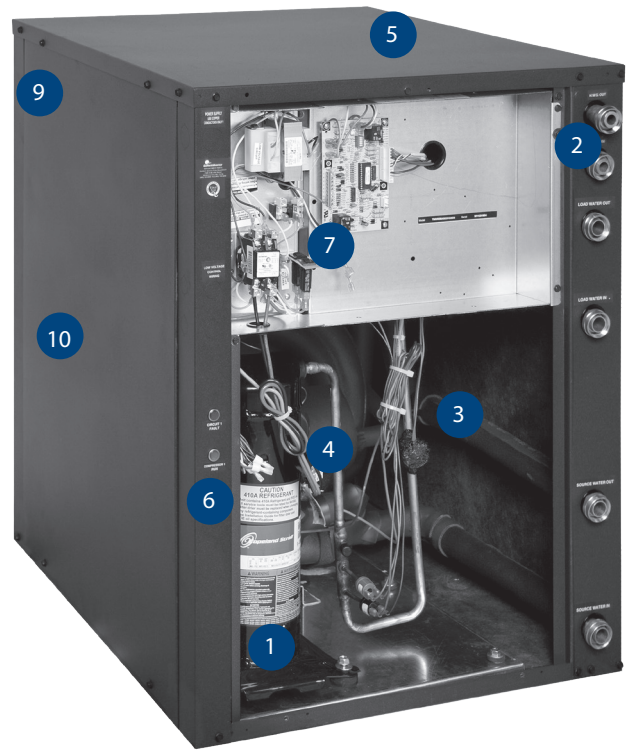

Unit Model Key

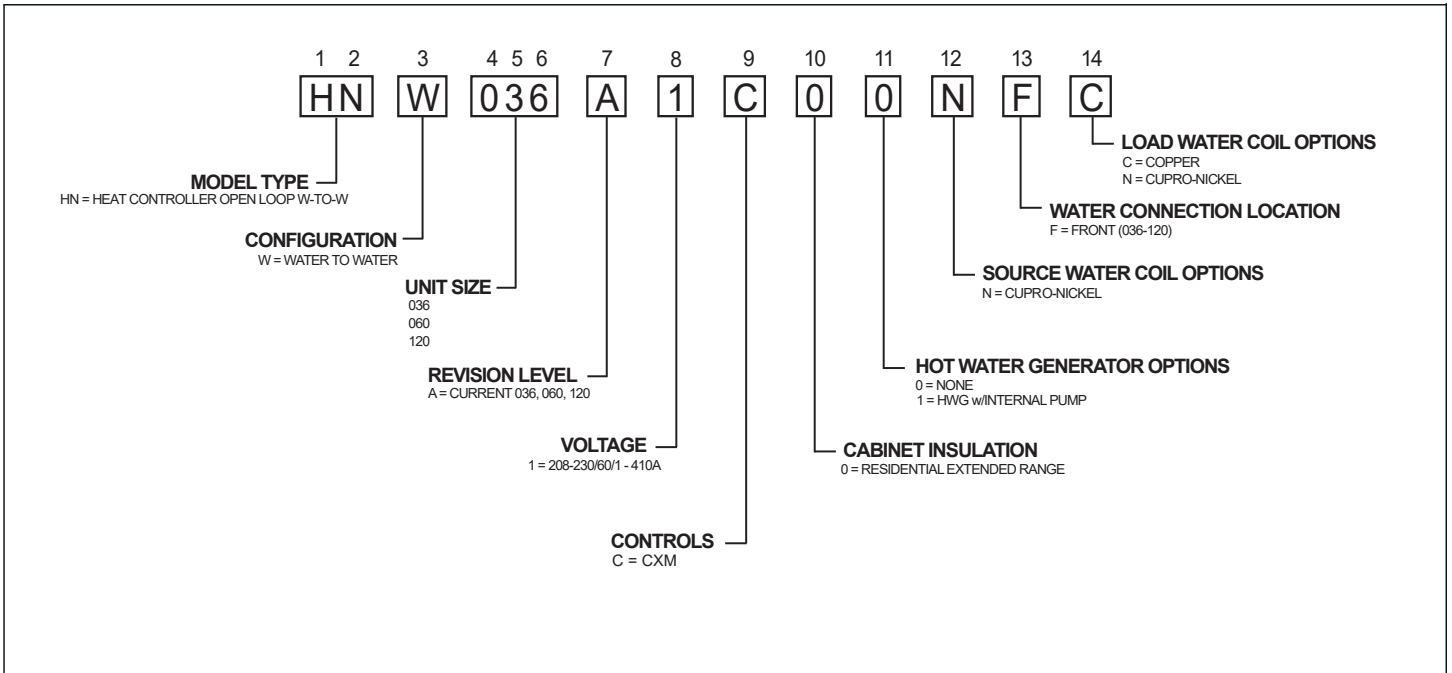

WARNING!

WARNING! TCW IS FOR GROUND WATER INSTALLATIONS ONLY. Installing TCW on closed loop system will void warranty and unit will not be eligible for federal tax credit.

AHRI/ISO/ASHRAE/ANSI 13256-2 Performance

ASHRAE/AHRI/ISO 13256-2. English (I-P) Units

Model	Ground Water Heat Pump			
	Cooling		Heating	
	Indoor 53.6°F Outdoor 77°F		Indoor 104°F Outdoor 32°F	
	Capacity Btuh	EER Btuh/W	Capacity Btuh	COP
HNW036	35,600	20.8	34,700	3.6
HNW060	60,900	20.8	58,600	3.5
HNW120	121,800	20.8	117,200	3.5

All ratings based upon 208V operation

ASHRAE/AHRI/ISO 13256-2. Metric (S-I) Units

Model	Ground Water Heat Pump			
	Cooling		Heating	
	Indoor 12°C Outdoor 25°C		Indoor 40°C Outdoor 0°C	
	Capacity Watts	EER W/W	Capacity Watts	COP
HNW036	10.43	6.1	10.17	3.6
HNW060	17.85	6.1	17.17	3.5
HNW120	35.70	6.1	34.35	3.5

All ratings based upon 208V operation

Performance Data Selection Notes

Source Water must be between 50° F (10° C) and 80° F (26° C) entering unit and flow 1.5 GPM per ton or higher. In cooling mode.

If unit load leaving water temperature (LWT) is below 40° F (4.4° C) installer must clip JW2 on CXM and add appropriate type of antifreeze and protect to 15° F (-9.5° C). Never clip JW3.

Antifreeze Correction Table

Antifreeze Type	Antifreeze %	Cooling			Heating		WPD Corr. Fct. EWT 30°F
		EWT 90°F			EWT 30°F		
		Total Cap	Sens Cap	Power	Htg Cap	Power	
Water	0	1.000	1.000	1.000	1.000	1.000	1.000
Propylene Glycol	5	0.995	0.995	1.003	0.989	0.997	1.070
	15	0.986	0.986	1.009	0.968	0.990	1.210
	25	0.978	0.978	1.014	0.947	0.983	1.360
Methanol	5	0.997	0.997	1.002	0.989	0.997	1.070
	15	0.990	0.990	1.007	0.968	0.990	1.160
	25	0.982	0.982	1.012	0.949	0.984	1.220
Ethanol	5	0.998	0.998	1.002	0.981	0.994	1.140
	15	0.994	0.994	1.005	0.944	0.983	1.300
	25	0.986	0.986	1.009	0.917	0.974	1.360
Ethylene Glycol	5	0.998	0.998	1.002	0.993	0.998	1.040
	15	0.994	0.994	1.004	0.980	0.994	1.120
	25	0.988	0.988	1.008	0.966	0.990	1.200

Performance Data — HNW036 - Cooling

SOURCE				LOAD																					
EWT °F	Flow			EWT °F	Flow 4.5 GPM						Flow 6.8 GPM						Flow 9.0 GPM								
	GPM	WPD			TC Mbtuh	Power kW	HR Mbtuh	LWT °F	EER	WPD		TC Mbtuh	Power kW	HR Mbtuh	LWT °F	EER	WPD		TC Mbtuh	Power kW	HR Mbtuh	LWT °F	EER	WPD	
		PSI	FT							PSI	FT						PSI	FT						PSI	FT
50	4.5	1.3	3.1	50	32.5	1.49	37.6	35.6	21.8	0.6	1.4	34.5	1.52	39.7	39.8	22.7	1.4	3.2	35.3	1.5	40.5	42.1	23.2	2.6	5.9
				60	36.8	1.53	42.0	43.6	24.1	0.5	1.2	38.4	1.54	43.6	48.6	24.9	1.3	3.1	39.2	1.5	44.5	51.3	25.3	2.5	5.8
				70	40.4	1.55	45.7	52.0	26.0	0.5	1.1	41.6	1.56	47.0	57.7	26.6	1.3	2.9	42.4	1.6	47.8	60.6	27.0	2.4	5.6
				80	43.2	1.57	48.6	60.8	27.5	0.4	0.9	44.2	1.58	49.6	66.9	28.0	1.2	2.8	44.8	1.6	50.3	70.0	28.1	2.3	5.4
				90	45.1	1.58	50.5	69.9	28.6	0.3	0.8	46.2	1.60	51.7	76.3	28.9	1.1	2.6	46.6	1.6	52.1	79.7	28.9	2.2	5.1
	6.8	3.4	7.8	50	32.9	1.41	37.7	35.4	23.3	0.6	1.4	34.9	1.44	39.8	39.7	24.2	1.4	3.2	35.8	1.4	40.7	42.0	24.8	2.6	5.9
				60	37.3	1.45	42.2	43.4	25.7	0.5	1.2	38.9	1.46	43.9	48.5	26.6	1.3	3.1	39.7	1.5	44.7	51.2	27.1	2.5	5.8
				70	40.9	1.47	46.0	51.8	27.8	0.5	1.1	42.2	1.48	47.2	57.5	28.4	1.3	2.9	42.9	1.5	48.0	60.5	28.8	2.4	5.6
				80	43.8	1.49	48.9	60.5	29.4	0.4	0.9	44.8	1.50	49.9	67.7	29.9	1.2	2.8	45.4	1.5	50.6	69.9	30.0	2.3	5.4
				90	45.7	1.50	50.8	69.7	30.5	0.3	0.8	Operation not recommended													
	9.0	6.0	13.9	50	33.3	1.33	37.8	35.2	25.1	0.6	1.4	35.4	1.35	40.0	39.5	26.1	1.4	3.2	36.2	1.4	40.9	41.9	26.8	2.6	5.9
				60	37.8	1.36	42.4	43.2	27.8	0.5	1.2	39.4	1.37	44.0	48.3	28.7	1.3	3.1	40.2	1.4	44.9	51.1	29.2	2.5	5.8
				70	41.5	1.38	46.2	51.6	30.0	0.5	1.1	42.7	1.39	47.5	57.3	30.7	1.3	2.9	43.5	1.4	48.3	60.3	31.1	2.4	5.6
				80	44.3	1.40	49.1	60.3	31.7	0.4	0.9	45.4	1.41	50.2	66.6	32.3	1.2	2.8	46.0	1.4	50.8	69.8	32.5	2.3	5.4
				90	46.3	1.41	51.1	69.4	33.0	0.3	0.8	Operation not recommended													
70	4.5	1.0	2.3	50	30.1	1.96	36.8	36.6	15.3	0.6	1.4	32.1	1.95	38.8	40.5	16.4	1.4	3.2	33.0	2.0	39.7	42.7	16.7	2.6	5.9
				60	34.1	1.98	40.9	44.8	17.2	0.5	1.2	37.6	1.96	44.3	48.9	19.2	1.3	3.1	36.6	2.0	43.3	51.9	18.7	2.5	5.8
				70	39.0	2.01	45.9	52.7	19.4	0.5	1.1	41.7	1.98	48.5	57.6	21.0	1.3	2.9	39.9	2.0	46.7	61.1	19.9	2.4	5.6
				80	42.7	2.03	49.7	61.0	21.1	0.4	1.0	45.4	2.01	52.3	66.5	22.5	1.2	2.8	42.9	2.0	49.8	70.5	21.1	2.3	5.4
				90	46.2	2.05	53.2	69.5	22.5	0.3	0.8	Operation not recommended													
	6.8	2.8	6.5	50	30.5	1.86	36.8	36.5	16.4	0.6	1.4	32.5	1.85	38.8	40.4	17.5	1.4	3.2	33.4	1.9	39.8	42.6	17.8	2.6	5.9
				60	34.6	1.88	41.0	44.6	18.4	0.5	1.2	38.1	1.86	44.4	48.7	20.4	1.3	3.1	37.1	1.9	43.4	51.8	19.9	2.5	5.8
				70	39.5	1.90	46.0	52.4	20.8	0.5	1.1	42.3	1.88	48.7	57.5	22.4	1.3	2.9	40.4	1.9	46.9	61.0	21.3	2.4	5.6
				80	43.3	1.93	49.9	60.8	22.5	0.4	0.9	46.0	1.91	52.5	66.4	24.1	1.2	2.8	43.4	1.9	50.0	70.3	22.5	2.3	5.4
				90	46.8	1.95	53.4	69.2	24.0	0.3	0.8	Operation not recommended													
	9.0	5.1	11.9	50	30.8	1.74	36.8	36.3	17.7	0.6	1.4	32.9	1.74	38.8	40.2	19.0	1.4	3.2	33.8	1.8	39.8	42.5	19.3	2.6	5.9
				60	35.0	1.76	41.0	44.4	19.9	0.5	1.2	38.6	1.75	44.5	48.6	22.1	1.3	3.1	37.5	1.7	43.5	51.7	21.5	2.5	5.8
				70	40.0	1.78	46.1	52.2	22.4	0.5	1.1	42.8	1.77	48.8	57.3	24.2	1.3	2.9	40.9	1.8	47.0	60.9	23.0	2.4	5.6
				80	43.8	1.81	50.0	60.5	24.3	0.4	0.9	46.6	1.79	52.7	66.2	26.0	1.2	2.8	44.0	1.8	50.2	70.2	24.3	2.3	5.4
				90	47.4	1.83	53.6	68.9	26.0	0.3	0.8	Operation not recommended													
80	4.5	0.9	2.1	50	28.5	2.26	36.2	37.3	13.0	0.6	1.4	30.5	2.27	38.3	36.4	13.8	1.4	3.2	31.3	2.27	39.1	36.1	14.1	2.6	5.9
				60	32.6	2.28	40.4	45.5	14.7	0.5	1.2	35.8	2.28	43.6	44.1	16.1	1.3	3.1	35.1	2.26	42.8	44.4	15.9	2.5	5.8
				70	37.6	2.30	45.5	53.3	16.7	0.5	1.1	40.3	2.30	48.2	52.1	17.9	1.3	2.9	38.6	2.30	46.5	52.8	17.2	2.4	5.6
				80	41.6	2.32	49.5	61.5	18.3	0.4	1.0	44.2	2.33	52.1	60.4	19.4	1.2	2.8	42.0	2.33	49.9	61.3	18.3	2.3	5.4
				90	45.2	2.35	53.2	69.9	19.6	0.3	0.8	Operation not recommended													
	6.75	2.6	6.0	50	28.9	2.14	36.2	41.4	13.8	0.6	1.4	30.9	2.16	38.2	40.8	14.7	1.4	3.2	31.7	2.16	39.1	40.6	15.1	2.6	5.9
				60	33.0	2.16	40.4	50.2	15.6	0.5	1.2	36.2	2.16	43.6	49.3	17.2	1.3	3.1	35.5	2.14	42.8	49.5	17.0	2.5	5.8
				70	38.1	2.18	45.6	58.7	17.8	0.5	1.1	40.8	2.18	48.3	57.9	19.2	1.3	2.9	39.1	2.18	46.6	58.4	18.3	2.4	5.6
				80	42.1	2.21	49.7	67.5	19.5	0.4	0.9	44.7	2.21	52.3	66.7	20.7	1.2	2.8	42.5	2.21	50.1	67.4	19.6	2.3	5.4
				90	45.8	2.23	53.3	76.4	20.9	0.3	0.8	Operation not recommended													
	9.0	4.8	11.1	50	29.3	2.01	36.1	43.5	14.9	0.6	1.4	31.3	2.02	38.2	43.0	15.9	1.4	3.2	32.1	2.02	39.0	42.9	16.3	2.6	5.9
				60	33.5	2.03	40.4	52.6	16.9	0.5	1.2	36.7	2.03	43.6	51.8	18.6	1.3	3.1	36.0	2.01	42.8	52.0	18.3	2.5	5.8
				70	38.6	2.05	45.6	61.4	19.3	0.5	1.1	41.3	2.05	48.3	60.8	20.7	1.3	2.9	39.6	2.04	46.6	61.2	19.8	2.4	5.6
				80	42.7	2.07	49.7	70.5	21.0	0.4	0.9	45.3	2.07	52.4	69.9	22.3	1.2	2.8	43.1	2.08	50.1	70.4	21.1	2.3	5.4
				90	46.3	2.09	53.4	79.7	22.6	0.3	0.8	Operation not recommended													

Interpolation is permissible, extrapolation is not
 All performance data is based upon the lower voltage of dual voltage rated units
 See performance data notes for operation in the shaded areas.
 Performance stated is at the rated power supply, performance may vary as the power supply varies from the rated

Performance Data — HNW036 - Heating

SOURCE					LOAD																				
EWT °F	Flow				EWT °F	Flow 4.5 GPM					Flow 6.8 GPM					Flow 9.0 GPM									
	GPM	WPD				HC Mbtuh	Power KW	HE Mbtuh	LWT °F	COP	WPD		HC Mbtuh	Power KW	HE Mbtuh	LWT °F	COP	WPD		HC Mbtuh	Power KW	HE Mbtuh	LWT °F	COP	WPD
PSI		FT	PSI	FT	PSI						FT	PSI						FT	PSI						FT
50	4.5	1.3	3.1	60	Operation Not Recommended																				
				80																					
				100																					
				120																					
				130																					
	6.75	3.4	7.8	60	37.7	1.56	32.4	76.8	7.1	0.5	1.2	38.4	1.48	33.3	71.4	7.6	1.3	3.1	38.5	1.44	33.6	68.6	7.9	2.5	5.8
				80	36.6	2.00	29.8	96.3	5.4	0.4	0.9	37.1	1.89	30.7	91.0	5.7	1.2	2.8	37.3	1.84	31.0	88.3	5.9	2.3	5.4
				100	35.2	2.60	26.3	115.6	4.0	0.3	0.7	35.5	2.46	27.1	110.5	4.2	1.1	2.5	35.5	2.40	27.3	107.9	4.3	2.1	4.9
				120	33.4	3.37	21.9	134.8	2.9	0.2	0.5	33.4	3.19	22.5	129.9	3.1	0.9	2.1	33.3	3.10	22.7	127.4	3.1	1.8	4.3
				130	Operation Not Recommended																				
	9.0	6.0	13.9	60	38.6	1.56	33.3	77.2	7.2	0.5	1.2	39.3	1.48	34.3	71.7	7.8	1.3	3.1	39.5	1.44	34.6	68.8	8.0	2.5	5.8
				80	37.5	2.01	30.7	96.7	5.5	0.4	0.9	38.0	1.90	31.6	91.3	5.9	1.2	2.8	38.2	1.85	31.9	88.5	6.1	2.3	5.4
				100	36.0	2.61	27.1	116.0	4.0	0.3	0.7	36.3	2.47	27.9	110.8	4.3	1.1	2.5	36.3	2.40	28.1	108.1	4.4	2.1	4.9
				120	34.0	3.37	22.5	135.1	3.0	0.2	0.5	34.1	3.19	23.2	130.1	3.1	0.9	2.1	34.0	3.11	23.4	127.6	3.2	1.8	4.3
				130	Operation Not Recommended																				
60	4.5	1.2	2.7	60	39.0	1.57	33.6	77.3	7.3	0.5	1.2	39.7	1.48	34.6	71.8	7.8	1.3	3.1	39.9	1.44	34.9	68.9	8.1	2.5	5.8
				80	38.6	2.01	31.8	97.2	5.6	0.4	0.9	39.2	1.90	32.7	91.6	6.0	1.2	2.8	39.3	1.85	33.0	88.7	6.2	2.3	5.4
				100	37.6	2.61	28.7	116.7	4.2	0.3	0.7	38.0	2.47	29.6	111.3	4.5	1.1	2.5	38.0	2.40	29.8	108.5	4.6	2.1	4.9
				120	36.0	3.37	24.5	136.0	3.1	0.2	0.5	36.1	3.19	25.2	130.7	3.3	0.9	2.1	36.0	3.11	25.4	128.0	3.4	1.8	4.3
				130	Operation not recommended																				
	6.75	3.1	7.1	60	40.6	1.57	35.3	78.1	7.6	0.5	1.2	41.4	1.49	36.3	72.3	8.2	1.3	3.1	41.6	1.45	36.6	69.2	8.4	2.5	5.8
				80	40.2	2.01	33.4	97.9	5.9	0.4	0.9	40.8	1.90	34.3	92.1	6.3	1.2	2.8	41.0	1.85	34.6	89.1	6.5	2.3	5.4
				100	39.1	2.61	30.2	117.4	4.4	0.3	0.7	39.5	2.47	31.0	111.7	4.7	1.1	2.5	39.5	2.41	31.3	108.8	4.8	2.1	4.9
				120	37.2	3.38	25.7	136.5	3.2	0.2	0.5	37.3	3.20	26.4	131.1	3.4	0.9	2.1	37.3	3.11	26.6	128.3	3.5	1.8	4.3
				130	Operation Not Recommended																				
	9.0	5.6	12.8	60	41.5	1.57	36.1	78.4	7.7	0.5	1.2	42.2	1.49	37.2	72.5	8.3	1.3	3.1	42.4	1.45	37.5	69.4	8.6	2.5	5.8
				80	41.0	2.01	34.1	98.2	6.0	0.4	0.9	41.6	1.91	35.1	92.3	6.4	1.2	2.8	41.8	1.86	35.5	89.3	6.6	2.3	5.4
				100	39.8	2.62	30.9	117.7	4.5	0.3	0.7	40.2	2.48	31.8	111.9	4.8	1.1	2.5	40.3	2.41	32.0	109.0	4.9	2.1	4.9
				120	37.8	3.38	26.3	136.8	3.3	0.2	0.5	38.0	3.20	27.0	131.2	3.5	0.9	2.1	37.9	3.12	27.3	128.4	3.6	1.8	4.3
				130	Operation Not Recommended																				
70	4.5	1.0	2.3	60	42.1	1.58	36.7	78.7	7.8	0.5	1.2	42.9	1.49	37.8	72.7	8.4	1.3	3.1	43.1	1.46	38.1	69.6	8.7	2.5	5.8
				80	42.4	2.02	35.5	98.8	6.2	0.4	0.9	43.0	1.91	36.5	92.7	6.6	1.2	2.8	43.2	1.86	36.8	89.6	6.8	2.3	5.4
				100	41.6	2.62	32.7	118.5	4.7	0.3	0.7	42.1	2.48	33.6	112.5	5.0	1.1	2.5	42.2	2.41	33.9	109.4	5.1	2.1	4.9
				120	39.8	3.38	28.3	137.7	3.5	0.2	0.5	40.0	3.20	29.1	131.9	3.7	0.9	2.1	40.0	3.12	29.4	128.9	3.8	1.8	4.3
				130	Operation Not Recommended																				
	6.75	2.8	6.5	60	43.6	1.58	38.2	79.4	8.1	0.5	1.2	44.4	1.50	39.3	73.2	8.7	1.3	3.1	44.7	1.46	39.7	69.9	9.0	2.5	5.8
				80	43.8	2.02	36.9	99.5	6.4	0.4	0.9	44.5	1.91	38.0	93.2	6.8	1.2	2.8	44.7	1.86	38.4	89.9	7.0	2.3	5.4
				100	43.0	2.62	34.0	119.1	4.8	0.3	0.7	43.5	2.49	35.0	112.9	5.1	1.1	2.5	43.6	2.42	35.3	109.7	5.3	2.1	4.9
				120	41.0	3.39	29.5	138.2	3.5	0.2	0.5	41.3	3.21	30.3	132.2	3.8	0.9	2.1	41.3	3.13	30.6	129.2	3.9	1.8	4.3
				130	Operation Not Recommended																				
	9.0	5.1	11.9	60	44.3	1.59	38.9	79.7	8.2	0.5	1.2	45.1	1.50	40.0	73.4	8.8	1.3	3.1	45.4	1.46	40.4	70.1	9.1	2.5	5.8
				80	44.5	2.02	37.6	99.8	6.4	0.4	0.9	45.2	1.92	38.7	93.4	6.9	1.2	2.8	45.4	1.87	39.1	90.1	7.1	2.3	5.4
				100	43.6	2.63	34.6	119.4	4.9	0.3	0.7	44.1	2.49	35.6	113.1	5.2	1.1	2.5	44.2	2.42	36.0	109.8	5.4	2.1	4.9
				120	41.6	3.40	30.0	138.5	3.6	0.2	0.5	41.8	3.22	30.9	132.4	3.8	0.9	2.1	41.8	3.13	31.1	129.3	3.9	1.8	4.3
				130	Operation Not Recommended																				
80	4.5	0.9	2.0	60	44.4	1.52	39.2	79.7	8.6	0.5	1.2	45.2	1.44	40.3	80.1	9.2	1.3	3.1	45.5	1.40	40.7	80.2	9.5	2.5	5.8
				90	45.6	1.94	38.9	100.2	6.9	0.4	0.9	46.3	1.84	40.1	100.6	7.4	1.2	2.8	46.5	1.79	40.4	100.7	7.6	2.3	5.4
				80	45.6	2.22	38.1	110.3	6.0	0.3	0.8	46.3	2.10	39.2	110.6	6.5	1.1	2.6	46.5	2.05	39.5	110.7	6.7	2.2	5.1
				100	45.4	2.54	36.7	120.2	5.2	0.3	0.7	46.0	2.41	37.8	120.4	5.6	1.1	2.5	46.1	2.34	38.1	120.5	5.8	2.1	4.9
				120	43.8	3.34	32.5	139.5	3.9	0.2	0.5	44.2	3.16	33.4	139.6	4.1	0.9	2.1	44.2	3.08	33.7	139.6	4.2	1.8	4.3
	130	Operation Not Recommended																							
	6.75	2.6	5.9	60	45.8	1.56	40.4	73.6	8.6	0.5	1.2	46.6	1.47	41.6	73.8	9.3	1.3	3.1	46.9	1.44	42.0	73.9	9.6	2.5	5.8
				90	46.8	1.99	40.0	93.9	6.9	0.4	0.9	47.6	1.88	41.2	94.1	7.4	1.2	2.8	47.8	1.83	41.5	94.2	7.6	2.3	5.4
				80	46.8	2.27	39.0	103.9	6.0	0.3	0.8	47.5	2.15	40.2	104.1	6.5	1.1	2.6	47.7	2.09	40.5	104.1	6.7	2.2	5.1
				100	46.4	2.59	37.6	113.7	5.2	0.3	0.7	47.0	2.45	38.6	113.9	5.6	1.1	2.5	47.1	2.39	39.0	114.0	5.8	2.1	4.9
				120	44.6	3.37	33.1	133.2	3.9	0.2	0.5	44.9	3.19	34.1	133.3	4.1	0.9	2.1	45.0	3.11	34.4	133.3	4.2	1.8	4.3
	130	Operation Not Recommended																							
	9.0	4.8	11.0	60	47.1	1.60	41.7	70.5	8.7	0.5	1.2	48.1	1.51	42.9	70.7	9.3	1.3	3.1	48.3	1.47	43.3	70.7	9.6	2.5	5.8
				90	48.0	2.03	41.1	90.7	6.9	0.4	0.9	48.8	1.93	42.3	90.9	7.4	1.2	2.8	49.0	1.88	42.7	90.9	7.7	2.3	5.4
				80	47.9	2.32	40.0	100.6	6.1	0.3	0.8	48.6	2.19	41.2	100.8	6.5	1.1	2.6	48.8	2.13	41.5	100.8	6.7	2.2	5.1
100				47.4	2.64	38.4	110.5	5.3	0.3	0.7	48.1	2.50	39.5	110.7	5.6	1.1	2.5	48.2	2.43	39.9	110.7	5.8	2.1	4.9	
120				45.4	3.41	33.7	130.1	3.9	0.2	0.5	45.7	3.23	34.7	130.2	4.2	0.9	2.1	45.8	3.14	35.0	130.2	4.3	1.8	4.3	

Interpolation is permissible, extrapolation is not.
 All performance data is based upon the lower voltage of dual voltage rated units.
 Performance data is not the rated power supply, performance may vary as the power supply varies from the rated.

Performance Data — HNW060 - Cooling

SOURCE				LOAD																					
EWT °F	Flow			EWT °F	Flow 7.5 GPM						Flow 11.25 GPM						Flow 15.0 GPM								
	GPM	WPD			TC Mbtuh	Power kW	HR Mbtuh	LWT °F	EER	WPD	TC Mbtuh	Power kW	HR Mbtuh	LWT °F	EER	WPD	TC Mbtuh	Power kW	HR Mbtuh	LWT °F	EER	WPD			
		PSI	FT						PSI	FT					PSI	FT					PSI	FT			
50	7.5	1.3	2.9	50	52.6	2.20	60.1	38.2	23.9	1.4	3.3	53.5	2.23	61.1	41.0	24.0	3.5	8.0	55.3	2.25	63.0	42.5	24.6	4.8	11.0
				60	53.2	2.22	60.8	47.1	23.9	1.4	3.2	54.1	2.25	61.7	50.5	24.1	3.3	7.7	55.9	2.27	63.7	52.4	24.7	4.6	10.6
				70	53.8	2.24	61.4	56.0	24.0	1.3	3.0	54.7	2.26	62.4	60.0	24.1	3.2	7.4	56.6	2.29	64.4	62.2	24.7	4.4	10.1
				80	55.5	2.24	63.2	64.7	24.7	1.2	2.9	56.4	2.27	64.1	69.4	24.9	3.1	7.1	58.4	2.29	66.2	72.0	25.5	4.3	9.8
	11.25	3.4	7.9	50	53.4	2.23	61.0	38.0	24.0	1.4	3.3	54.1	2.25	61.8	40.8	24.1	3.5	8.0	56.0	2.27	63.8	42.3	24.7	4.8	11.0
				60	55.5	2.25	63.1	46.7	24.7	1.4	3.2	56.2	2.27	64.0	50.1	24.8	3.3	7.7	58.2	2.29	66.0	52.0	25.4	4.6	10.6
				70	57.5	2.26	65.3	55.4	25.4	1.3	3.0	58.3	2.29	66.1	59.4	25.5	3.2	7.4	60.4	2.31	68.3	61.6	26.1	4.4	10.2
				80	58.1	2.27	65.8	64.3	25.6	1.2	2.9	58.9	2.29	66.7	69.0	25.7	3.1	7.1	60.9	2.31	68.8	71.5	26.4	4.3	9.8
	15.0	6.2	14.2	50	55.6	2.25	63.2	35.8	24.7	1.4	3.3	56.5	2.27	64.2	40.3	24.9	3.5	8.0	57.9	2.29	65.8	42.1	25.2	4.8	11.1
				60	57.5	2.27	65.2	45.0	25.3	1.4	3.2	58.7	2.29	66.6	49.8	25.6	3.3	7.7	61.5	2.31	69.4	51.5	26.6	4.6	10.6
				70	59.4	2.29	67.2	54.1	26.0	1.3	3.0	61.0	2.31	68.9	59.3	26.4	3.2	7.4	65.1	2.33	73.1	60.9	27.9	4.4	10.1
				80	60.3	2.29	68.1	63.5	26.4	1.2	2.9	61.8	2.31	69.7	68.7	26.7	3.1	7.1	65.8	2.34	73.8	70.8	28.2	4.2	9.8
70	7.5	1.1	2.5	50	49.1	2.82	58.7	38.1	17.4	1.4	3.3	50.3	2.85	60.0	41.1	17.7	3.5	8.0	52.0	2.88	61.8	42.9	18.1	4.7	11.0
				60	53.2	2.84	62.9	46.4	18.7	1.4	3.2	54.5	2.87	64.3	50.0	19.0	3.3	7.7	56.3	2.90	66.2	52.3	19.4	4.6	10.5
				70	57.2	2.86	67.0	54.8	20.0	1.3	3.0	58.7	2.89	68.5	59.1	20.3	3.2	7.4	60.6	2.92	70.6	61.7	20.8	4.4	10.1
				80	59.3	2.92	69.3	63.4	20.3	1.2	2.9	60.8	2.95	70.9	68.3	20.6	3.1	7.1	62.9	2.98	73.0	71.4	21.1	4.3	9.8
	11.25	3.0	6.9	50	50.2	2.85	59.9	38.0	17.6	1.4	3.3	51.4	2.88	61.2	41.0	17.8	3.5	8.0	53.1	2.91	63.0	42.8	18.3	4.8	11.0
				60	54.5	2.87	64.3	46.2	19.0	1.4	3.2	55.9	2.90	65.8	49.8	19.3	3.3	7.7	57.7	2.93	67.7	52.1	19.7	4.6	10.6
				70	58.9	2.89	68.8	54.5	20.4	1.3	3.0	60.4	2.92	70.3	58.8	20.7	3.2	7.4	62.4	2.94	72.4	61.4	21.2	4.4	10.2
				80	60.8	2.95	70.8	63.1	20.6	1.2	2.9	62.3	2.98	72.4	68.1	20.9	3.1	7.1	64.4	3.01	74.6	71.1	21.4	4.3	9.9
	15.0	5.5	12.8	50	51.2	2.88	61.0	36.9	17.8	1.4	3.3	53.3	2.91	63.2	40.8	18.3	3.5	8.0	54.3	2.94	64.3	42.6	18.5	4.8	11.0
				60	55.6	2.90	65.5	45.4	19.2	1.4	3.2	57.6	2.93	67.6	49.6	19.7	3.3	7.7	59.4	2.96	69.5	51.8	20.1	4.6	10.6
				70	60.1	2.92	70.1	53.9	20.6	1.3	3.0	61.9	2.94	72.0	58.5	21.0	3.2	7.4	64.5	2.97	74.6	61.1	21.7	4.4	10.1
				80	62.3	2.98	72.5	62.7	20.9	1.2	2.9	64.1	3.01	74.4	67.8	21.3	3.1	7.1	67.1	3.04	77.5	70.6	22.1	4.2	9.8
80	7.5	1.0	2.3	50	47.3	3.13	58.0	38.0	15.1	1.4	3.3	48.7	3.16	59.5	41.1	15.4	3.5	8.0	50.3	3.19	61.2	43.1	15.8	4.7	10.9
				60	53.1	3.15	63.9	46.1	16.9	1.4	3.2	54.7	3.18	65.6	49.8	17.2	3.3	7.7	56.5	3.21	67.5	52.3	17.6	4.6	10.5
				70	58.9	3.17	69.7	54.2	18.6	1.3	3.0	60.7	3.20	71.6	58.6	19.0	3.2	7.4	62.7	3.23	73.7	61.5	19.4	4.4	10.1
				80	61.3	3.25	72.4	62.7	18.8	1.2	2.9	63.1	3.29	74.3	67.8	19.2	3.1	7.1	65.1	3.32	76.5	71.1	19.6	4.3	9.8
	11.25	2.8	6.5	50	48.5	3.16	59.3	38.0	15.3	1.4	3.3	50.0	3.19	60.9	41.1	15.6	3.5	8.0	51.6	3.23	62.6	43.0	16.0	4.8	11.1
				60	54.1	3.18	64.9	46.0	17.0	1.4	3.2	55.7	3.21	66.6	49.7	17.3	3.3	7.7	57.5	3.24	68.6	52.2	17.7	4.6	10.6
				70	59.6	3.20	70.5	54.0	18.7	1.3	3.0	61.4	3.23	72.4	58.4	19.0	3.2	7.4	63.4	3.26	74.5	61.3	19.4	4.4	10.2
				80	62.1	3.29	73.4	62.5	18.9	1.2	2.9	64.0	3.32	75.3	67.6	19.3	3.1	7.1	66.1	3.35	77.5	70.9	19.7	4.3	9.9
	15.0	5.3	12.1	50	49.0	3.19	59.9	37.4	15.3	1.4	3.3	51.7	3.23	62.7	41.0	16.0	3.5	8.0	52.4	3.26	63.5	42.9	16.1	4.8	11.0
				60	54.7	3.21	65.7	45.6	17.0	1.4	3.2	57.1	3.24	68.1	49.5	17.6	3.3	7.7	58.3	3.28	69.5	52.0	17.8	4.6	10.6
				70	60.5	3.23	71.5	53.8	18.7	1.3	3.0	62.4	3.26	73.5	58.1	19.1	3.2	7.4	64.2	3.30	75.4	61.1	19.5	4.4	10.1
				80	63.3	3.32	74.7	62.3	19.1	1.2	2.9	65.3	3.35	76.7	67.4	19.5	3.1	7.1	67.8	3.39	79.3	70.5	20.0	4.3	9.8
90	66.2	3.41	77.9	70.8	19.4	1.2	2.7	68.2	3.45	79.9	76.7	19.8	3.0	6.9	71.4	3.48	83.2	80.0	20.5	4.1	9.6				

Interpolation is permissible, extrapolation is not
 All performance data is based upon the lower voltage of dual voltage rated units
 See performance data notes for operation in the shaded areas.
 Performance stated is at the rated power supply, performance may vary as the power supply varies from the rated

Performance Data — HNW060 - Heating

SOURCE				LOAD																								
EWT °F	Flow			EWT °F	Flow 7.5 GPM						Flow 11.25 GPM						Flow 15.0 GPM											
	GPM	WPD			HC Mbtuh	Power kW	HE Mbtuh	LWT °F	COP	WPD		HC Mbtuh	Power kW	HE Mbtuh	LWT °F	COP	WPD		HC Mbtuh	Power kW	HE Mbtuh	LWT °F	COP	WPD				
		PSI	FT							PSI	FT						PSI	FT						PSI	FT	PSI	FT	PSI
50	7.5	1.3	2.9	60	OPERATION NOT RECOMMENDED																							
				80	OPERATION NOT RECOMMENDED																							
				100	OPERATION NOT RECOMMENDED																							
				120	OPERATION NOT RECOMMENDED																							
				130	OPERATION NOT RECOMMENDED																							
	11.25	3.4	7.9	60	64.7	2.73	55.4	77.4	6.9	1.4	3.2	65.1	2.68	56.0	71.3	7.1	3.3	7.7	65.5	2.62	56.5	68.5	7.3	6.0	13.8			
				80	62.8	3.52	50.8	96.9	5.2	1.2	2.9	63.1	3.45	51.4	91.3	5.4	3.1	7.1	63.4	3.38	51.9	88.3	5.5	5.6	13.0			
				100	60.8	4.48	45.5	116.2	4.0	1.1	2.6	61.0	4.39	46.0	110.9	4.1	2.9	6.7	61.1	4.30	46.5	108.0	4.2	5.3	12.3			
				120	58.6	5.61	39.4	135.4	3.1	1.1	2.4	58.6	5.50	39.8	130.2	3.1	2.8	6.4	58.6	5.39	40.2	127.7	3.2	5.1	11.7			
				130	OPERATION NOT RECOMMENDED																							
	15.0	6.2	14.2	60	66.5	2.76	57.1	78.0	7.1	1.4	3.2	66.9	2.70	57.7	71.9	7.3	3.3	7.7	67.3	2.65	58.3	69.0	7.4	6.0	13.8			
				80	64.7	3.55	52.6	97.2	5.3	1.2	2.9	65.0	3.48	53.1	91.6	5.5	3.1	7.1	65.3	3.41	53.6	88.6	5.6	5.6	13.0			
				100	62.5	4.52	47.1	116.4	4.1	1.1	2.6	62.7	4.43	47.6	111.1	4.1	2.9	6.7	62.9	4.34	48.0	108.2	4.2	5.3	12.3			
				120	60.0	5.67	40.6	135.6	3.1	1.1	2.4	60.0	5.55	41.0	130.5	3.2	2.8	6.4	60.0	5.44	41.4	127.9	3.2	5.1	11.7			
				130	OPERATION NOT RECOMMENDED																							
60	7.5	1.2	2.7	60	64.9	2.76	55.5	78.5	6.9	1.4	3.2	65.2	2.70	56.0	71.7	7.1	3.3	7.7	65.6	2.65	56.6	68.6	7.3	6.0	13.8			
				80	64.8	3.54	52.7	98.1	5.4	1.2	2.9	65.1	3.47	53.3	91.8	5.5	3.1	7.1	65.4	3.40	53.8	88.6	5.6	5.6	13.0			
				100	63.7	4.49	48.3	117.6	4.2	1.1	2.6	63.9	4.40	48.8	111.5	4.3	2.9	6.7	64.1	4.31	49.4	108.4	4.4	5.3	12.3			
				120	61.4	5.60	42.3	136.7	3.2	1.1	2.4	61.5	5.48	42.8	130.9	3.3	2.8	6.4	61.6	5.37	43.2	128.0	3.4	5.1	11.7			
				130	Operation not recommended																							
	11.25	3.2	7.3	60	67.7	2.78	58.2	79.0	7.1	1.4	3.2	68.1	2.73	58.8	72.2	7.3	3.3	7.7	68.5	2.67	59.4	69.1	7.5	6.0	13.8			
				80	67.7	3.58	55.5	98.7	5.5	1.2	2.9	68.0	3.51	56.0	92.3	5.7	3.1	7.1	68.3	3.44	56.6	89.1	5.8	5.6	13.0			
				100	66.4	4.54	50.9	118.1	4.3	1.1	2.6	66.6	4.45	51.5	112.0	4.4	2.9	6.7	66.9	4.36	52.0	108.9	4.5	5.3	12.3			
				120	64.0	5.67	44.6	137.2	3.3	1.1	2.4	64.1	5.56	45.1	131.3	3.4	2.8	6.4	64.2	5.45	45.6	128.5	3.5	5.1	11.7			
				130	OPERATION NOT RECOMMENDED																							
	15.0	5.8	13.5	60	70.0	2.81	60.4	79.4	7.3	1.4	3.2	70.4	2.76	61.0	72.6	7.5	3.3	7.7	70.8	2.70	61.6	69.5	7.7	6.0	13.8			
				80	70.0	3.62	57.7	99.0	5.7	1.2	2.9	70.4	3.54	58.3	92.6	5.8	3.1	7.1	70.7	3.47	58.9	89.4	6.0	5.6	13.0			
				100	68.8	4.60	53.1	118.3	4.4	1.1	2.6	69.0	4.50	53.6	112.2	4.5	2.9	6.7	69.2	4.41	54.2	109.1	4.6	5.3	12.3			
				120	66.2	5.75	46.6	137.4	3.4	1.1	2.4	66.3	5.63	47.1	131.6	3.4	2.8	6.4	66.4	5.52	47.5	128.7	3.5	5.1	11.7			
				130	OPERATION NOT RECOMMENDED																							
70	7.5	1.1	2.5	60	68.6	2.81	59.0	80.1	7.2	1.4	3.2	69.0	2.76	59.6	72.6	7.3	3.3	7.7	69.5	2.70	60.2	69.2	7.5	6.0	13.8			
				80	69.8	3.61	57.5	100.0	5.7	1.2	2.9	70.2	3.53	58.1	92.8	5.8	3.1	7.1	70.5	3.46	58.7	89.4	6.0	5.6	13.0			
				100	69.2	4.55	53.6	119.5	4.5	1.1	2.6	69.4	4.46	54.2	112.6	4.6	2.9	6.7	69.7	4.37	54.8	109.3	4.7	5.3	12.3			
				120	66.7	5.64	47.4	138.5	3.5	1.1	2.4	66.8	5.52	47.9	132.0	3.5	2.8	6.4	66.9	5.41	48.5	128.9	3.6	5.1	11.7			
				130	OPERATION NOT RECOMMENDED																							
	11.25	3.0	6.9	60	70.7	2.84	61.0	80.7	7.3	1.4	3.2	71.2	2.78	61.7	73.2	7.5	3.3	7.7	71.6	2.73	62.3	69.7	7.7	6.0	13.8			
				80	72.5	3.64	60.1	100.5	5.8	1.2	2.9	72.9	3.57	60.7	93.3	6.0	3.1	7.1	73.2	3.50	61.3	89.9	6.1	5.6	13.0			
				100	72.1	4.61	56.3	119.9	4.6	1.1	2.6	72.3	4.52	56.9	113.1	4.7	2.9	6.7	72.6	4.43	57.5	109.7	4.8	5.3	12.3			
				120	69.4	5.73	49.9	139.0	3.5	1.1	2.4	69.6	5.62	50.4	132.4	3.6	2.8	6.4	69.7	5.51	50.9	129.3	3.7	5.1	11.7			
				130	OPERATION NOT RECOMMENDED																							
	15.0	5.5	12.8	60	73.5	2.87	63.7	80.9	7.5	1.4	3.2	73.9	2.81	64.3	73.4	7.7	3.3	7.7	74.4	2.75	65.0	70.0	7.9	6.0	13.8			
				80	75.4	3.68	62.8	100.7	6.0	1.2	2.9	75.8	3.61	63.5	93.5	6.2	3.1	7.1	76.2	3.53	64.1	90.1	6.3	5.6	13.0			
				100	75.1	4.67	59.1	120.2	4.7	1.1	2.6	75.3	4.57	59.7	113.3	4.8	2.9	6.7	75.6	4.48	60.3	109.9	4.9	5.3	12.3			
				120	72.5	5.83	52.6	139.2	3.6	1.1	2.4	72.6	5.71	53.1	132.7	3.7	2.8	6.4	72.7	5.60	53.6	129.5	3.8	5.1	11.7			
				130	OPERATION NOT RECOMMENDED																							
80	7.5	1.0	2.3	60	72.4	2.87	62.6	81.7	7.4	1.4	3.2	72.8	2.81	63.2	73.5	7.6	3.3	7.7	73.3	2.75	63.9	69.8	7.8	6.0	13.8			
				80	74.8	3.67	62.3	101.8	6.0	1.2	2.9	75.2	3.60	62.9	93.9	6.1	3.1	7.1	75.6	3.52	63.6	90.2	6.3	5.6	13.0			
				100	74.7	4.61	58.9	121.4	4.8	1.1	2.6	75.0	4.51	59.6	113.8	4.9	2.9	6.7	75.3	4.42	60.2	110.2	5.0	5.3	12.3			
				120	71.9	5.68	52.5	140.4	3.7	1.1	2.4	72.1	5.56	53.1	133.2	3.8	2.8	6.4	72.3	5.45	53.7	129.8	3.9	5.1	11.7			
				130	OPERATION NOT RECOMMENDED																							
	11.25	2.8	6.5	60	73.7	2.89	63.9	82.3	7.5	1.4	3.2	74.2	2.84	64.5	74.1	7.7	3.3	7.7	74.7	2.78	65.2	70.3	7.9	6.0	13.8			
				80	77.3	3.71	64.7	102.3	6.1	1.2	2.9	77.7	3.63	65.3	94.3	6.3	3.1	7.1	78.2	3.56	66.0	90.6	6.4	5.6	13.0			
				100	77.7	4.67	61.8	121.8	4.9	1.1	2.6	78.0	4.58	62.4	114.2	5.0	2.9	6.7	78.4	4.49	63.0	110.6	5.1	5.3	12.3			
				120	74.8	5.79	55.1	140.7	3.8	1.1	2.4	75.0	5.68	55.7	133.5	3.9	2.8	6.4	75.2	5.56	56.2	130.1	4.0	5.1	11.7			
				130	OPERATION NOT RECOMMENDED																							
	15.0	5.3	12.1	60	76.9	2.92	67.0	82.4	7.7	1.4	3.2	77.4	2.87	67.6	74.2	7.9	3.3	7.7	77.9	2.81	68.3	70.4	8.1	6.0	13.8			
				80	80.7	3.74	68.0	102.5	6.3	1.2	2.9	81.2	3.67	68.7	94.5	6.5	3.1	7.1	81.6	3.60	69.3	90.8	6.7	5.6	13.0			
				100	81.3	4.74	65.2	122.0	5.0	1.1	2.6	81.7	4.64	65.8	114.4	5.2	2.9	6.7	82.0	4.55	66.5	110.8	5.3	5.3	12.3			
				120	78.7	5.91	58.5	141.0	3.9	1.1	2.4	78.9	5.79	59.1	133.8	4.0	2.8	6.4	79.1	5.68	59.7	130.4	4.1	5.1	11.7			
				130	OPERATION NOT RECOMMENDED																							
				130	OPERATION NOT RECOMMENDED																							

Interpolation is permissible, extrapolation is not.
 All performance data is based upon the lower voltage of dual voltage rated units
 Performance stated is at the rated power supply, performance may vary as the power supply varies from the rated

Performance Data — HNW120 - Cooling

SOURCE					LOAD																					
EWT °F	Flow				EWT °F	Flow 15.0 GPM						Flow 22.5 GPM						Flow 30.0 GPM								
	GPM	WPD				TC Mbtuh	Power kW	HR Mbtuh	LWT °F	EER	PSI	FT	TC Mbtuh	Power kW	HR Mbtuh	LWT °F	EER	PSI	FT	TC Mbtuh	Power kW	HR Mbtuh	LWT °F	EER	PSI	FT
		PSI	FT	FT																						
50	15.0	1.4	3.2	50	105.2	4.41	120.3	38.2	23.9	1.6	3.7	106.9	4.45	122.1	41.0	24.0	3.8	8.8	110.7	4.50	126.0	42.5	24.6	6.8	15.7	
				60	106.4	4.45	121.6	47.1	23.9	1.5	3.5	108.1	4.49	123.4	50.5	24.1	3.7	8.4	111.9	4.54	127.4	45.2	24.7	6.6	15.2	
				70	107.6	4.48	122.9	56.0	24.0	1.4	3.3	109.3	4.53	124.8	60.0	24.1	3.5	8.1	113.1	4.57	128.7	62.2	24.7	6.4	14.7	
				80	111.0	4.49	126.3	64.7	24.7	1.4	3.2	112.8	4.53	128.3	69.4	24.9	3.4	7.9	116.7	4.58	132.4	72.0	25.5	6.2	14.3	
	22.5	3.8	8.7	50	106.8	4.45	122.0	38.0	24.0	1.6	3.7	108.3	4.50	123.6	40.8	24.1	3.8	8.8	112.1	4.54	127.6	42.3	24.7	6.8	15.7	
				60	110.9	4.49	126.2	46.7	24.7	1.5	3.5	112.5	4.54	128.0	50.1	24.8	3.7	8.4	116.4	4.58	132.0	52.0	25.4	6.6	15.2	
				70	115.1	4.53	130.5	55.4	25.4	1.4	3.3	116.7	4.57	132.3	59.4	25.5	3.5	8.1	120.8	4.62	136.5	61.6	26.1	6.4	14.7	
				80	116.1	4.53	131.6	64.3	25.6	1.4	3.2	117.7	4.58	133.4	69.0	25.7	3.4	7.9	121.9	4.62	137.6	71.5	26.4	6.2	14.3	
	30.0	6.8	15.6	50	117.2	4.54	132.6	73.2	25.8	1.3	3.0	118.8	4.58	134.5	78.5	25.9	3.3	7.6	123.0	4.63	138.8	81.4	26.6	6.0	13.9	
				60	111.1	4.50	126.5	35.8	24.7	1.6	3.7	113.0	4.54	128.5	40.3	24.9	3.8	8.8	115.9	4.59	131.5	42.1	25.2	6.8	15.7	
				70	114.9	4.54	130.4	45.0	25.3	1.5	3.5	117.5	4.58	133.1	49.8	25.6	3.7	8.4	120.0	4.63	135.8	51.5	26.6	6.6	15.2	
				80	118.8	4.57	134.4	54.1	26.0	1.4	3.3	122.0	4.62	137.8	59.3	26.4	3.5	8.1	130.2	4.67	146.1	60.9	27.9	6.4	14.7	
70	15.0	1.2	2.7	50	98.2	5.64	117.5	38.1	17.4	1.6	3.7	100.6	5.70	120.1	41.1	17.7	3.8	8.8	104.0	5.76	123.7	42.9	18.1	6.8	15.7	
				60	106.3	5.88	125.7	46.4	18.7	1.5	3.5	109.0	5.74	128.6	50.0	19.0	3.7	8.4	112.6	5.79	132.4	52.3	19.4	6.6	15.2	
				70	114.4	5.71	133.9	54.8	20.0	1.4	3.3	117.3	5.77	137.0	59.1	20.3	3.5	8.1	121.3	5.83	141.2	61.7	20.8	6.4	14.7	
				80	118.7	5.83	138.6	63.4	20.3	1.4	3.2	121.7	5.89	141.8	68.3	20.6	3.4	7.9	125.7	5.95	146.1	71.4	21.1	6.2	14.3	
	22.5	3.3	7.6	50	100.3	5.70	119.8	38.0	17.6	1.6	3.7	102.7	5.76	122.4	41.0	17.8	3.8	8.8	106.2	5.82	126.0	42.8	18.3	6.8	15.7	
				60	109.1	5.74	128.7	46.2	19.0	1.5	3.5	111.7	5.79	131.5	49.8	19.3	3.7	8.4	115.5	5.85	135.4	52.1	19.7	6.6	15.2	
				70	117.9	5.77	137.6	54.5	20.4	1.4	3.3	120.7	5.83	140.6	58.8	20.7	3.5	8.1	124.8	5.89	144.9	61.4	21.2	6.4	14.7	
				80	121.6	5.89	141.7	63.1	20.6	1.4	3.2	124.5	5.95	144.9	68.1	20.9	3.4	7.9	128.7	6.01	149.2	71.1	21.4	6.2	14.3	
	30.0	6.1	14.1	50	125.2	6.02	145.8	71.7	20.8	1.3	3.0	128.3	6.08	149.1	77.3	21.1	3.3	7.6	132.6	6.14	153.6	80.8	21.6	6.0	13.9	
				60	102.4	5.76	122.0	36.9	17.8	1.6	3.7	106.6	5.82	126.4	40.8	18.3	3.8	8.8	108.5	5.88	128.6	42.6	18.5	6.8	15.7	
				70	111.3	5.79	131.1	45.4	19.2	1.5	3.5	115.2	5.85	135.2	49.6	19.7	3.7	8.4	118.8	5.91	138.9	51.8	20.1	6.6	15.2	
				80	120.2	5.83	140.1	53.9	20.6	1.4	3.3	123.9	5.89	144.0	58.5	21.0	3.5	8.1	129.0	5.95	149.3	61.1	21.7	6.4	14.7	
80	15.0	1.1	2.5	50	94.7	6.26	116.1	38.0	15.1	1.6	3.7	97.5	6.33	119.1	41.1	15.4	3.8	8.8	100.7	6.39	122.5	43.1	15.8	6.8	15.7	
				60	106.3	6.30	127.8	46.1	16.9	1.5	3.5	109.4	6.36	131.1	49.8	17.2	3.7	8.4	113.0	6.42	134.9	52.3	17.6	6.6	15.2	
				70	117.9	6.33	139.5	54.2	18.6	1.4	3.3	121.4	6.39	143.2	58.6	19.0	3.5	8.1	125.3	6.46	147.4	61.5	19.4	6.4	14.7	
				80	122.5	6.51	144.7	62.7	18.8	1.4	3.2	126.1	6.57	148.6	67.8	19.2	3.4	7.9	130.3	6.64	152.9	71.1	19.6	6.2	14.3	
	22.5	3.1	7.1	50	97.1	6.33	118.7	38.0	15.3	1.6	3.7	99.9	6.39	121.7	41.1	15.6	3.8	8.8	103.2	6.45	125.2	43.0	16.0	6.8	15.7	
				60	108.2	6.36	129.9	46.0	17.0	1.5	3.5	111.4	6.42	133.3	49.7	17.3	3.7	8.4	115.0	6.49	137.1	52.2	17.7	6.6	15.2	
				70	119.3	6.39	141.1	54.0	18.7	1.4	3.3	122.8	6.46	144.8	58.4	19.0	3.5	8.1	126.8	6.52	149.1	61.3	19.4	6.4	14.7	
				80	124.3	6.57	146.7	62.5	18.9	1.4	3.2	127.9	6.64	150.6	67.6	19.3	3.4	7.9	132.1	6.71	155.0	70.9	19.7	6.2	14.3	
	30.0	5.8	13.4	50	129.3	6.75	152.3	71.0	19.1	1.3	3.0	133.1	6.82	156.4	76.8	19.5	3.3	7.6	137.5	6.89	161.0	80.6	19.9	6.0	13.9	
				60	98.0	6.39	119.8	37.4	15.3	1.6	3.7	103.4	6.45	125.4	41.0	16.0	3.8	8.8	104.8	6.52	127.1	42.9	16.1	6.8	15.7	
				70	109.5	6.42	131.4	45.6	17.0	1.5	3.5	114.1	6.49	136.3	49.5	17.6	3.7	8.4	116.6	6.55	139.0	52.0	17.8	6.6	15.2	
				80	120.9	6.46	143.0	53.8	18.7	1.4	3.3	124.8	6.52	147.1	58.1	19.1	3.5	8.1	128.4	6.59	150.9	61.1	19.5	6.4	14.7	
30.0	5.8	13.4	50	126.7	6.64	149.3	62.3	19.1	1.4	3.2	130.6	6.71	153.5	76.4	19.5	3.4	7.9	135.6	6.78	158.7	70.5	20.0	6.2	14.3		
			60	132.4	6.82	155.7	70.8	19.4	1.3	3.0	136.3	6.89	159.8	81.7	19.8	3.3	7.6	142.7	6.96	166.5	80.0	20.5	6.0	13.9		

Interpolation is permissible, extrapolation is not.
 All performance data is based upon the lower voltage of dual voltage rated units.
 See performance data notes for operation in the shaded areas.
 Performance stated is at the rated power supply, performance may vary as the power supply varies from the rated.

Performance Data — HNW120 - Heating

SOURCE				LOAD																								
EWT °F	Flow			EWT °F	Flow 15.0 GPM								Flow 22.5 GPM								Flow 30.0 GPM							
	GPM	WPD PSI	FT		HC Mbtuh	Power kW	HE Mbtuh	LWT °F	COP	WPD PSI	FT	HC Mbtuh	Power kW	HE Mbtuh	LWT °F	COP	WPD PSI	FT	HC Mbtuh	Power kW	HE Mbtuh	LWT °F	COP	WPD PSI	FT			
50	15.0	1.4	3.2	60	OPERATION NOT RECOMMENDED																							
				80	OPERATION NOT RECOMMENDED																							
				100	OPERATION NOT RECOMMENDED																							
				120	OPERATION NOT RECOMMENDED																							
	22.5	3.8	8.7	60	129.4	5.46	110.8	77.4	6.9	1.5	3.5	130.2	5.35	111.9	71.3	7.1	3.3	7.7	131.0	5.24	113.1	68.5	7.3	6.0	13.8			
				80	125.7	7.04	101.7	96.9	5.2	1.4	3.2	126.3	6.90	102.7	91.3	5.4	3.1	7.1	126.8	6.76	103.8	88.3	5.5	5.6	13.0			
				100	121.6	8.96	91.0	116.2	4.0	1.3	2.9	121.9	8.78	92.0	110.9	4.1	2.9	6.7	122.3	8.60	92.9	108.0	4.2	5.3	12.3			
				120	117.2	11.22	78.9	135.4	3.1	1.2	2.7	117.2	11.00	79.7	130.2	3.1	2.8	6.4	117.3	10.78	80.5	127.7	3.2	5.1	11.7			
	30.0	6.8	15.6	60	133.0	5.51	114.2	78.0	7.1	1.5	3.5	133.8	5.40	115.3	71.9	7.3	3.3	7.7	134.6	5.30	116.5	69.0	7.4	6.0	13.8			
				80	129.4	7.11	105.1	97.2	5.3	1.4	3.2	130.0	6.97	106.2	91.6	5.5	3.1	7.1	130.6	6.83	107.3	88.6	5.6	5.6	13.0			
				100	125.0	9.05	94.2	116.4	4.1	1.3	2.9	125.4	8.87	95.1	111.1	4.1	2.9	6.7	125.7	8.69	96.1	108.2	4.2	5.3	12.3			
				120	119.9	11.34	81.2	135.6	3.1	1.2	2.7	120.0	11.11	82.1	130.5	3.2	2.8	6.4	120.0	10.89	82.9	127.9	3.2	5.1	11.7			
60	15.0	1.3	3.0	60	129.7	5.51	110.9	78.5	6.9	1.5	3.5	130.5	5.40	112.1	71.7	7.1	3.3	7.7	131.3	5.30	113.2	68.6	7.3	6.0	13.8			
				80	129.6	7.09	105.4	98.1	5.4	1.4	3.2	130.2	6.95	106.5	91.8	5.5	3.1	7.1	130.9	6.81	107.6	88.6	5.6	5.6	13.0			
				100	127.3	8.98	96.7	117.6	4.2	1.3	2.9	127.7	8.80	97.7	111.5	4.3	2.9	6.7	128.2	8.63	98.7	108.4	4.4	5.3	12.3			
				120	122.8	11.19	84.7	136.7	3.2	1.2	2.7	123.0	10.97	85.6	130.9	3.3	2.8	6.4	123.2	10.75	86.5	128.0	3.4	5.1	11.7			
	22.5	3.5	8.1	60	135.5	5.57	116.4	79.0	7.1	1.5	3.5	136.3	5.46	117.6	72.2	7.3	3.3	7.7	137.1	5.35	118.8	69.1	7.5	6.0	13.8			
				80	135.3	7.16	110.9	98.7	5.5	1.4	3.2	136.0	7.02	112.1	92.3	5.7	3.1	7.1	136.7	6.88	113.2	89.1	5.8	5.6	13.0			
				100	132.9	9.09	101.9	118.1	4.3	1.3	2.9	133.3	8.90	102.9	112.0	4.4	2.9	6.7	133.7	8.73	104.0	108.9	4.5	5.3	12.3			
				120	128.0	11.34	89.3	137.2	3.3	1.2	2.7	128.2	11.12	90.2	131.3	3.4	2.8	6.4	128.3	10.89	91.2	128.5	3.5	5.1	11.7			
	30.0	6.4	14.8	60	140.0	5.63	120.8	79.4	7.3	1.5	3.5	140.8	5.51	122.0	72.6	7.5	3.3	7.7	141.7	5.40	123.2	69.5	7.7	6.0	13.8			
				80	140.1	7.23	115.4	99.0	5.7	1.4	3.2	140.8	7.09	116.6	92.6	5.8	3.1	7.1	141.5	6.95	117.7	89.4	6.0	5.6	13.0			
				100	137.6	9.19	106.2	118.3	4.4	1.3	2.9	138.0	9.01	107.3	112.2	4.5	2.9	6.7	138.5	8.83	108.4	109.1	4.6	5.3	12.3			
				120	132.4	11.50	93.2	137.4	3.4	1.2	2.7	132.6	11.27	94.1	131.6	3.4	2.8	6.4	132.7	11.04	95.1	128.7	3.5	5.1	11.7			
70	15.0	1.2	2.7	60	137.2	5.62	118.0	80.1	7.2	1.5	3.5	138.1	5.51	119.3	72.6	7.3	3.3	7.7	138.9	5.40	120.5	69.2	7.5	6.0	13.8			
				80	139.6	7.21	115.0	100.0	5.7	1.4	3.2	140.3	7.07	116.2	92.8	5.8	3.1	7.1	141.1	6.93	117.4	89.4	6.0	5.6	13.0			
				100	138.3	9.01	107.3	119.5	4.5	1.3	2.9	138.8	8.92	108.4	112.6	4.6	2.9	6.7	139.4	8.74	109.6	109.3	4.7	5.3	12.3			
				120	133.3	11.27	94.9	138.5	3.5	1.2	2.7	133.6	11.05	95.9	132.0	3.5	2.8	6.4	133.9	10.83	96.9	128.9	3.6	5.1	11.7			
	22.5	3.3	7.6	60	141.5	5.68	122.1	80.7	7.3	1.5	3.5	142.3	5.57	123.3	73.2	7.5	3.3	7.7	143.2	5.46	124.6	69.7	7.7	6.0	13.8			
				80	145.0	7.29	120.1	100.5	5.8	1.4	3.2	145.7	7.14	121.4	93.3	6.0	3.1	7.1	146.5	7.00	122.6	89.9	6.1	5.6	13.0			
				100	144.1	9.22	112.7	119.9	4.6	1.3	2.9	144.7	9.03	113.9	113.1	4.7	2.9	6.7	145.2	8.85	115.0	109.7	4.8	5.3	12.3			
				120	138.9	11.46	99.7	139.0	3.5	1.2	2.7	139.1	11.24	100.8	132.4	3.6	2.8	6.4	139.4	11.01	101.8	129.3	3.7	5.1	11.7			
	30.0	6.1	14.1	60	146.9	5.74	127.3	80.9	7.5	1.5	3.5	147.8	5.62	128.6	73.4	7.7	3.3	7.7	148.7	5.50	129.9	70.0	7.9	6.0	13.8			
				80	150.8	7.36	125.7	100.7	6.0	1.4	3.2	151.6	7.21	126.9	93.5	6.2	3.1	7.1	152.3	7.07	128.2	90.1	6.3	5.6	13.0			
				100	150.1	9.33	118.3	120.2	4.7	1.3	2.9	150.7	9.15	119.5	113.3	4.8	2.9	6.7	151.3	8.97	120.7	109.9	4.9	5.3	12.3			
				120	144.9	11.66	105.1	139.2	3.6	1.2	2.7	145.2	11.43	106.2	132.7	3.7	2.8	6.4	145.5	11.20	107.3	129.5	3.8	5.1	11.7			
80	15.0	1.1	2.5	60	144.7	5.73	125.2	81.7	7.4	1.5	3.5	145.6	5.62	128.5	73.5	7.6	3.3	7.7	146.5	5.51	127.8	69.8	7.8	6.0	13.8			
				80	149.6	7.34	124.6	101.8	6.0	1.4	3.2	150.4	7.19	125.9	93.9	6.1	3.1	7.1	151.2	7.05	127.2	90.2	6.3	5.6	13.0			
				100	149.3	9.21	117.9	121.4	4.8	1.3	2.9	149.9	9.03	119.1	113.8	4.9	2.9	6.7	150.6	8.85	120.4	110.2	5.0	5.3	12.3			
				120	143.8	11.35	105.1	140.4	3.7	1.2	2.7	144.2	11.13	106.2	133.2	3.8	2.8	6.4	144.5	10.91	107.3	129.8	3.9	5.1	11.7			
	22.5	3.1	7.1	60	147.5	5.79	127.7	82.3	7.5	1.5	3.5	148.4	5.67	129.0	74.1	7.7	3.3	7.7	149.3	5.56	130.3	70.3	7.9	6.0	13.8			
				80	154.7	7.41	129.4	102.3	6.1	1.4	3.2	155.5	7.26	130.7	94.3	6.3	3.1	7.1	156.3	7.12	132.0	90.6	6.4	5.6	13.0			
				100	155.4	9.34	123.5	121.8	4.9	1.3	2.9	156.0	9.16	124.8	114.2	5.0	2.9	6.7	156.7	8.97	126.1	110.6	5.1	5.3	12.3			
				120	149.7	11.59	110.2	140.7	3.8	1.2	2.7	150.1	11.35	111.3	133.5	3.9	2.8	6.4	150.4	11.13	112.5	130.1	4.0	5.1	11.7			
	30.0	5.8	13.4	60	153.9	8.85	133.9	82.4	7.7	1.5	3.5	154.8	5.73	135.3	74.2	7.9	3.3	7.7	155.8	5.62	136.6	70.4	8.1	6.0	13.8			
				80	161.5	7.49	135.9	102.5	6.3	1.4	3.2	162.3	7.34	137.3	94.5	6.5	3.1	7.1	163.2	7.19	138.7	90.8	6.7	5.6	13.0			
				100	162.7	9.48	130.3	122.0	5.0	1.3	2.9	163.3	9.29	131.6	114.4	5.2	2.9	6.7	164.0	9.10	133.0	110.8	5.3	5.3	12.3			
				120	157.4	11.82	117.1	141.0	3.9	1.2	2.7	157.8	11.59	118.3	133.8	4.0	2.8	6.4	158.2	11.36	119.4	130.4	4.1	5.1	11.7			
130																	152.5	12.25	110.7	139.9	3.6	5.0	11.5					

Interpolation is permissible, extrapolation is not.
 All performance data is based upon the lower voltage of dual voltage rated units.
 Performance stated is at the rated power supply, performance may vary as the power supply varies from the rated.

Physical Data

Model	036	060	120
Compressor (qty)	Scroll (1)		Scroll (2)
Factory Charge HFC-410A (oz) [kg] Per Circuit	72 [2.04]	96 [2.49]	96 [2.49]
Water Connection Size			
Source/Load	1" Swivel		1-1/2 FPT
HWG (in)	1" Swivel		1/2" FPT
Weight - Operating (lbs) [kg]	348 [158]	360 [163]	726 [329]
Weight - Packaged (lbs) [kg]	373 [169]	385 [175]	770 [349]
Water Volume (Source)			
Gallons (Liters)	0.96 (3.64)	1.33 (5.04)	2.65 (10.02)

Dual isolated compressor mounting
 Balanced port expansion valve (TXV)
 Insulated Source and Load Water Coils standard
 Insulated Refrigerant Circuit standard
 Compressor on (green) and fault (red) light

Electrical Data

Model	Voltage Code	Rated Voltage	Min/Max Voltage	Compressor			HWG Pump FLA	EXT Loop Pump FLA	Total Unit FLA	Min Circuit Amps	Max Fuse/HACR
				RLA	LRA	QTY					
036	G	208-230/60/1	197/252	16.7	79.0	1	0.5	4.0	21.2	25.3	40
060	G	208-230/60/1	197/252	26.3	134.0	1	0.5	4.0	30.8	37.3	60
120	G	208-230/60/1	197/252	26.3	134.0	2	0.5	4.0	57.1	63.6	80

HACR circuit breaker in USA only
 Residential units come standard with 75VA transformer, HWG pump, and HWG connections

Dimensions - HNW036, HNW060 & HNW120

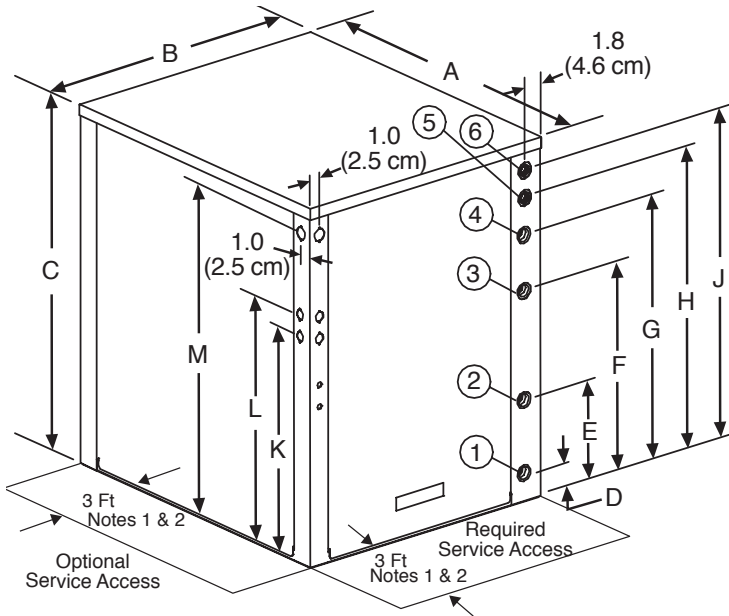

Notes:

1. Front & side access is preferred for service access. However, all components may be serviced from the front access panel if side access is not available.
2. While clear access to all removable panels is not required, installer should take care to comply with all building codes and allow adequate clearance for future field service.

HNW 036, 060

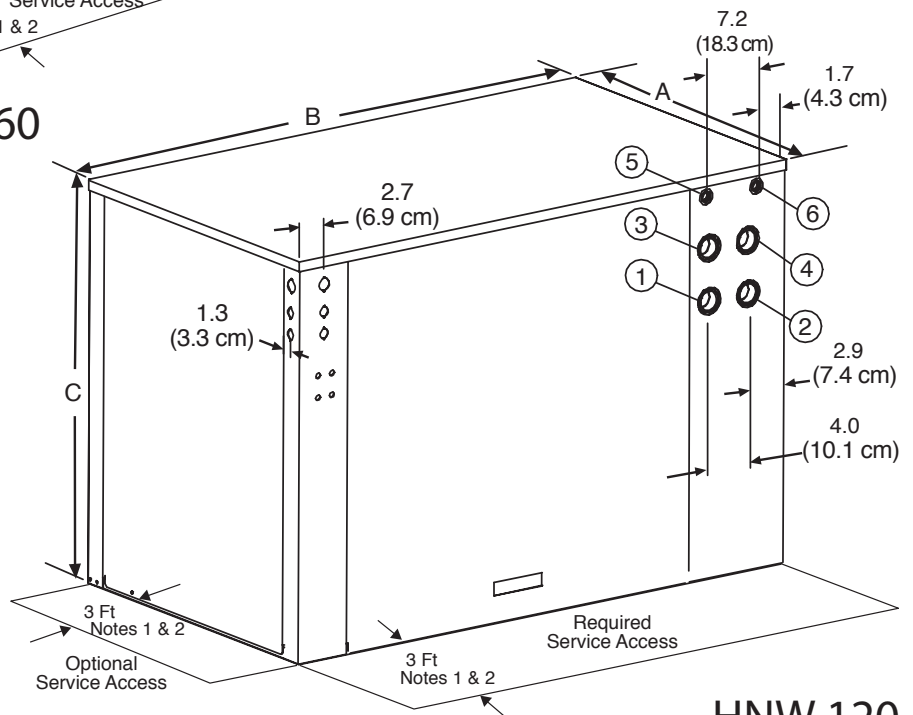

HNW 120

Water to Water	Overall Cabinet			Water Connections						Electric Access Plugs			
				1	2	3	4	5	6				
	A Depth	B Width	C Height	D Source (Outdoor) Water In	E Source (Outdoor) Water Out	F Load (Indoor) Water In	G Load (Indoor) Water Out	H HWG Water In	J HWG Water Out	K Low Voltage	L External Pump	M Power Supply	
036-060	in.	30.6	25.4	33	2.7	9.4	19.4	24.5	27.9	30.4	20.9	22.9	30.9
	cm.	77.8	64.5	83.8	6.9	23.9	49.3	62.2	70.9	77.2	53.1	58.2	78.5
120	in.	30.6	52.9	37	25.2	25.2	30.1	30.1	34.9	34.9	29.9	31.9	34.4
	cm.	77.8	134.4	94	64.0	64.0	76.5	76.5	88.6	88.6	75.9	81.0	87.4

HNW036 & HNW060 Electrical Wiring Diagram - 96B0223N11

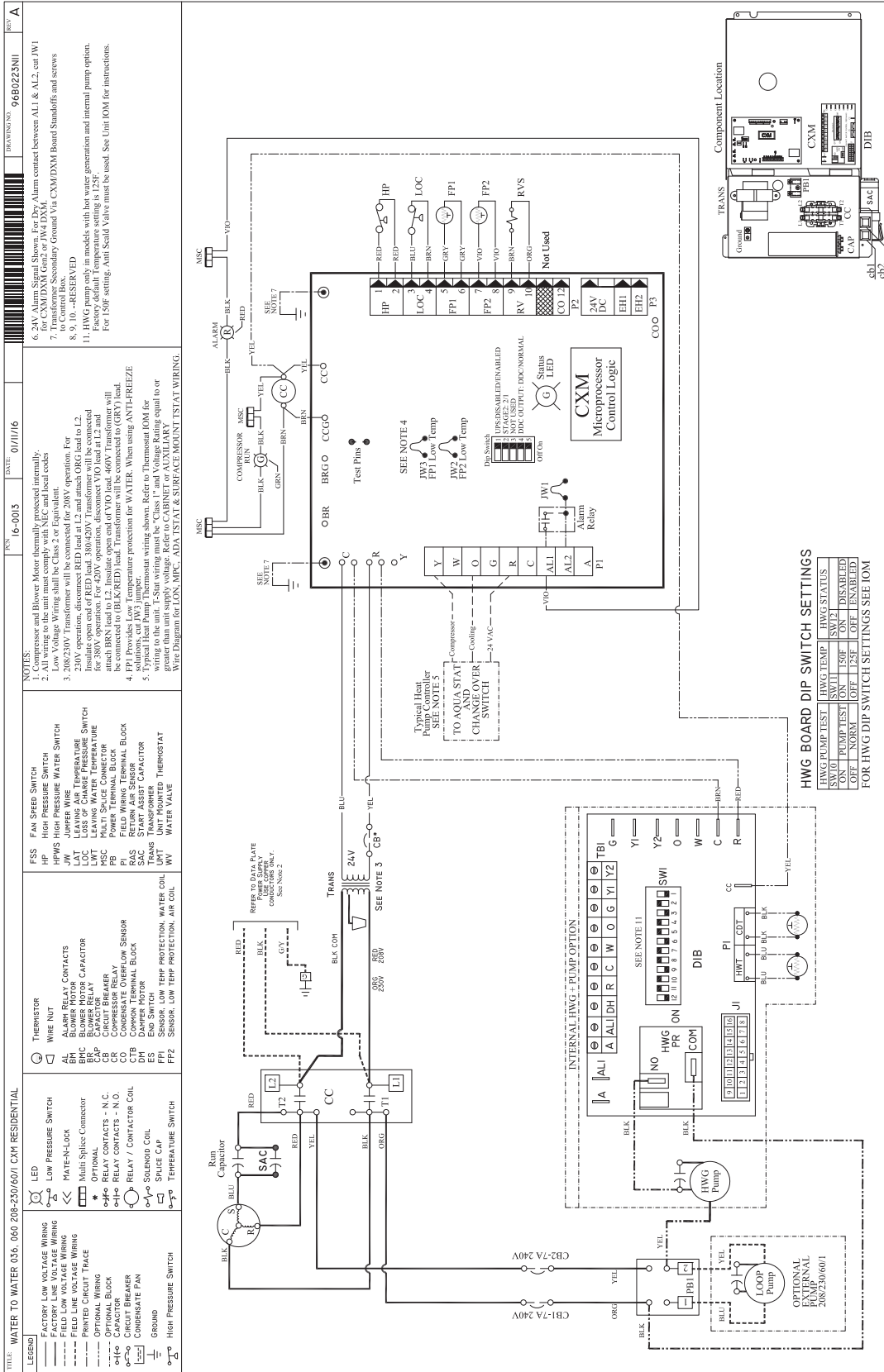

HNW120 Electrical Wiring Diagram - 96B0225N11

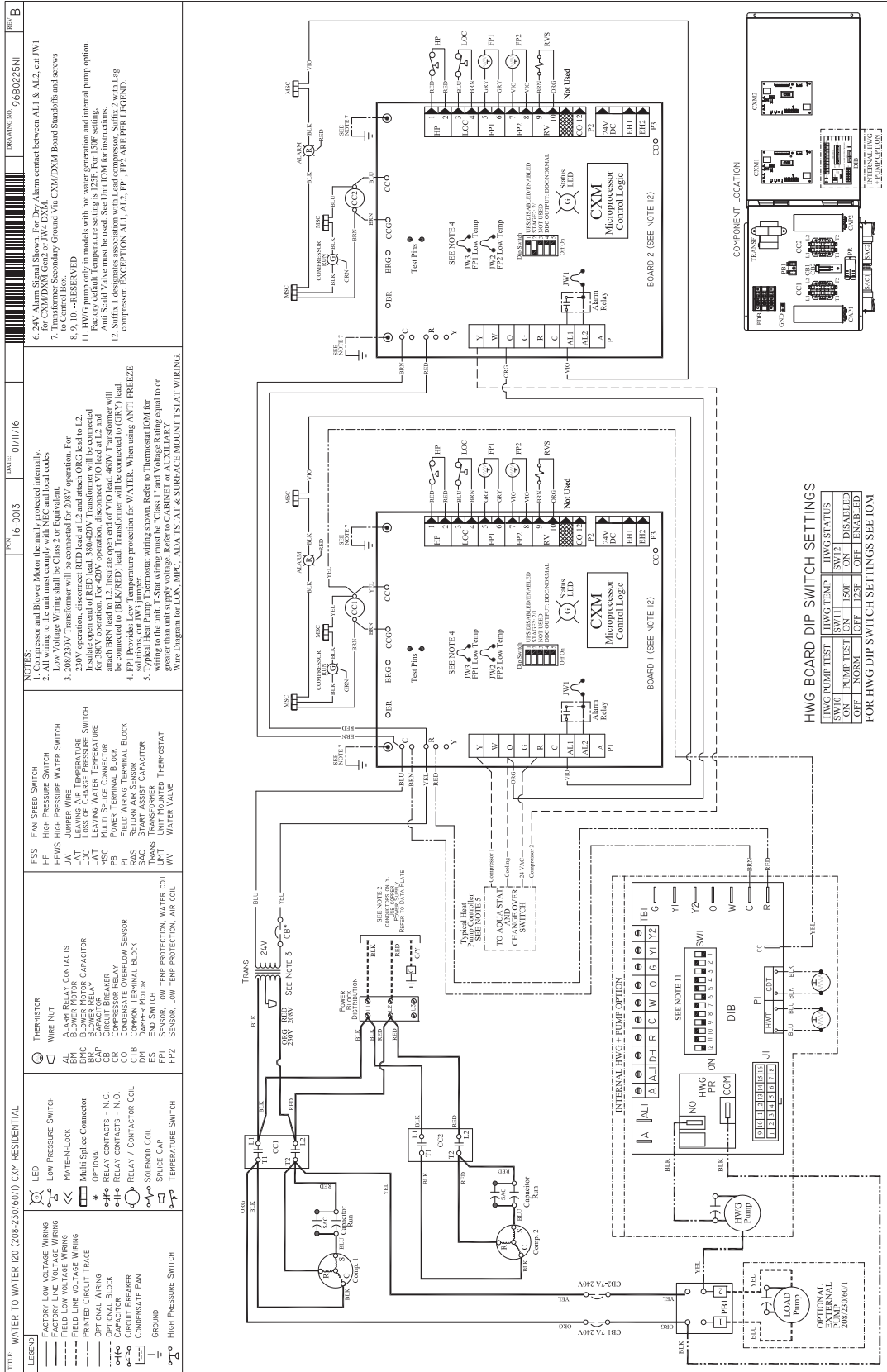



LIMITED EXPRESS WARRANTY

Congratulations on purchasing your new HVAC equipment. It's been designed for long life and reliable service, and is backed by one of the strongest warranties in the industry. Your unit automatically qualifies for the warranty coverage listed below, providing you keep your proof of purchase (receipt) for the equipment and meet the warranty conditions.

LIMITED TEN (10) YEAR EXPRESS WARRANTY

Heat Controller warrants all parts of the HEW/HNW residential geothermal heat pump including the compressor to be free from defects in workmanship and materials for normal use and maintenance for ten (10) years from the date of purchase by the original consumer for the original installation. This Express Limited Warranty applies only when the system is installed per Heat Controller installation instructions and in accordance with all local, state and national codes for normal use. Thermostats, auxiliary electric heaters, and geothermal pump flow centers purchased through Heat Controller and installed with an HEW or HNW geothermal heat pump will be covered by the same ten (10) year express warranty. All other accessories will have one (1) year.

LIMITED FIVE (5) YEAR LABOR ALLOWANCE

Labor is allowed for warranty service for a period of five (5) years from the date of purchase when the unit is properly registered and commissioned according to the start-up procedure specified in the Installation/Operation Manual, and when the Geothermal Start-Up Certification Form is completed and submitted to Heat Controller.

EXCEPTIONS

The Limited Express Warranty does not cover normal maintenance—Heat Controller recommends that regular inspection/maintenance be performed at least once a season and proof of maintenance be kept. Additionally, labor charges, transportation charges for replacement parts, replacement of refrigerant or filters, any other service calls/repairs are not covered by this Limited Warranty. It also does not cover any portion or component of the system that is not supplied by Heat Controller, regardless of the cause of failure of such portion or component.

CONDITIONS FOR WARRANTY COVERAGE

- Unit must be operated according to Heat Controller operating instructions included with the unit and cannot have been subjected to accident, alteration, improper repair, neglect or misuse, or an act of God (such as a flood)
- Installation was done by a trained, licensed or otherwise qualified HVAC dealer/contractor
- Performance cannot be impaired by use of any product not authorized by Heat Controller, or by any adjustments or adaptations to components
- Serial numbers and/or rating plate have not been altered or removed
- Damage has not been a result of inadequate wiring or voltage conditions, use during brown-out conditions, or circuit interruptions
- Air flow around any section of the unit has not been restricted
- Unit remains in the original installation

- Unit was not purchased over the internet

DURATION OF WARRANTY & REGISTRATION

The warranty begins on the date of purchase by the original consumer. The consumer must retain a receipted bill of sale as proof of warranty period. Without this proof, the express warranty begins on the date of shipment from the factory.

REMEDY PROVIDED BY THE LIMITED EXPRESS WARRANTY

The sole remedy under the Limited Warranty is replacement of the defective part. If replacement parts are required within the period of this warranty, Heat Controller replacement parts shall be used; any warranty on the replacement part(s) shall not affect the applicable original unit warranty. Ready access to the unit for service is the owner's responsibility. Labor to diagnose and replace the defective part is not covered by this Limited Express Warranty. If for any reason the replacement part/product is no longer available during the warranty period, Heat Controller shall have the right to allow a credit in the amount of the current suggested retail price of the part/product instead of providing repair or replacement.

LIMITATION OF LIABILITY

1. There are no other express or implied warranties. Heat Controller makes no warranty of merchantability. We do not warrant that the unit is suitable for any particular purpose or can be used in buildings or rooms of any particular size or condition except as specifically provided in this document. There are no other warranties, express or implied, which extend beyond the description in this document.
2. All warranties implied by law are limited in duration to the seven-year term of the parts warranty. Your exclusive remedy is limited to the replacement of defective parts. **We will not be liable for any consequential or incidental damages caused by any defect in this unit.**
3. This warranty gives you specific legal rights and you may also have other rights which vary from state to state. Some states do not allow limitation on how long an implied warranty lasts or do not allow the exclusion or limitation of incidental or consequential damages, so the above limitations or exclusions may not apply to you.
4. No warranties are made for units sold outside the continental United States and Canada. Your distributor or final seller may provide a warranty on units sold outside these areas.
5. Heat Controller will not be liable for damages if our performance regarding warranty resolution is delayed by events beyond our control including accident, alteration, abuse, war, government restrictions, strikes, fire, flood, or other acts of God.

HOW TO OBTAIN WARRANTY SERVICE OR PARTS

If you have a warranty claim, notify your installer promptly. If the installer does not remedy your claim, write to Heat Controller, 1900 Wellworth Ave., Jackson MI 49203. Enclose a report of inspection by your installer or service person. Include model number, serial number, and date of purchase.

Owner responsibilities are set forth in the instruction manual—read it carefully.



Please visit www.heatcontroller.com to register your new product.

KEEP THIS INFORMATION AS A RECORD OF YOUR PURCHASE

GEOHERMAL HEAT PUMP

INSTALLATION

Model Number

Installer Name

Serial Number

Phone Number/Contact Information

Date of Purchase

Date Installation Completed

Component of new HVAC system

Replacement heat pump only

Remember to retain your bill of sale as proof of warranty period.

Notes

Accessories & Options

Hot Water Generator

The optional Hot Water Generator includes an insulated double wall vented heat reclaiming heat exchanger suitable for potable water. The heat exchanger coil and hot water circulating pump are factory mounted internal to the unit. The microprocessor Hot Water Generator control uses sensors to monitor the entering potable water temperature and the compressor discharge line temperature and allows the Hot Water Generator to operate any time conditions permit. The Hot Water Generator includes a pump sampling mode to sense the hot water storage temperature while the Hot Water Generator is inactive.

Flow Controller (field installed)

A self-contained module shall provide all fluid pumping requirements for systems up to 20 GPM. The Flow Controller shall provide 1" pump isolation valves and 3-way service valves. Pump heads shall be removable from the volute for easy replacement. The Flow Controller shall be enclosed in a polystyrene case and fully insulated with urethane foam to prevent condensation. The Flow Controller shall have a 5-year warranty on all parts.

Hose Connection Kit (field installed)

An accessory hose kit shall provide 150psi 1" rubber hose with brass fittings equipped with service pressure/temperature ports for connection between the unit and Flow Controller.

Revision History

Date	Page #	Description
April 14, 2016	2,3,7,18	Updated series features, warranty and deleted engineering specs.
December 14, 2015	All	Published

Due to ongoing product improvements, specifications and dimensions are subject to change and correction without notice or incurring obligations. Determining the application and suitability for use of any product is the responsibility of the installer. Additionally, the installer is responsible for verifying dimensional data on the actual product prior to beginning any installation preparations.

Incentive and rebate programs have precise requirements as to product performance and certification. All products meet applicable regulations in effect on date of manufacture; however, certifications are not necessarily granted for the life of a product. Therefore, it is the responsibility of the applicant to determine whether a specific model qualifies for these incentive/rebate programs.

The logo for Comfort-Cire, featuring the brand name in a stylized, cursive script font with a registered trademark symbol.The logo for Century, featuring the brand name in a bold, sans-serif font with a stylized winged or flame-like graphic element to the left of the text.