Comfort-Cire®

Century®

**Installation, Operation &
Maintenance**

**Geothermal Open Loop Water-to-
Water HNW Series**

Water-to-Water
Water-Source Heat Pumps

Table of Contents

Model Nomenclature	3
Safety	4
General Information	4
Physical Data	6
Dimensional Data	7
Unit Installation	8
Water Connection Installation	8
Ground-Water Heat Pump Applications	9
Water Quality Requirements	11
Load Side Plumbing Installation	14
Hot Water Generator	15
Electrical – Line Voltage	18
Electrical – Low Voltage Wiring	19
Controls – DXM2.5	20
Unit Commissioning & Operating Limits	21
Unit & System Checkout	22
Unit Start-Up Procedure	23
Operating Pressures	25
Preventive Maintenance	27
Troubleshooting Form	28
Warranty	29
Revision History	32

Model Nomenclature

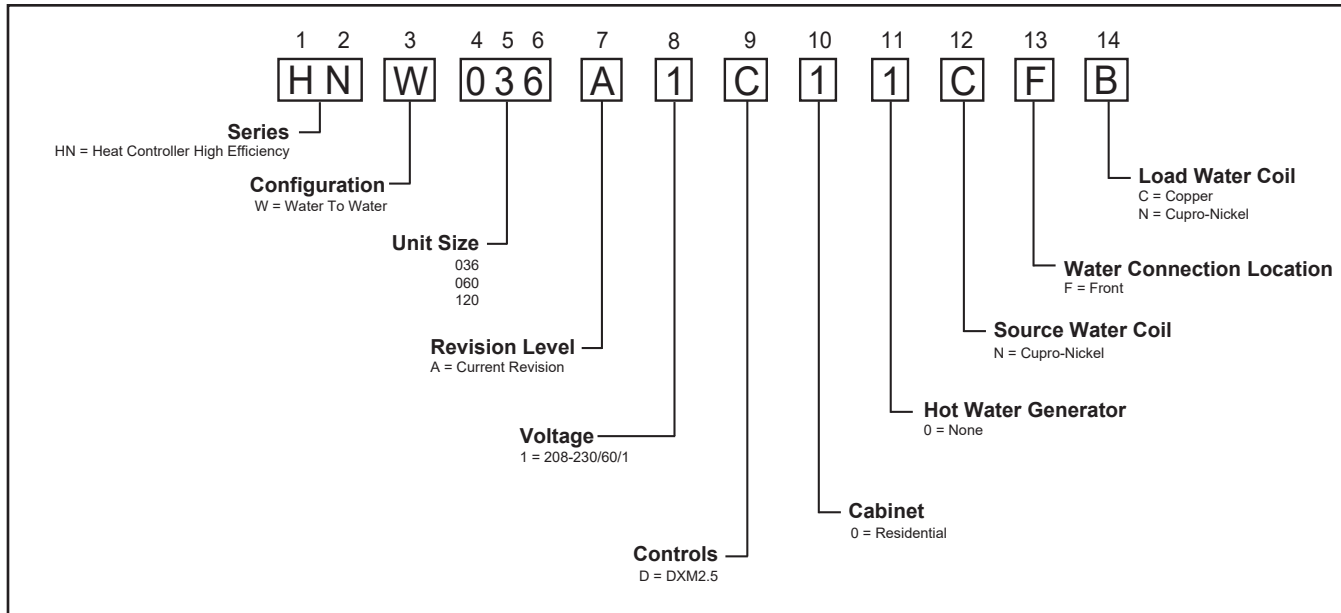

⚠ WARNING! ⚠

WARNING! HNW IS FOR GROUND WATER INSTALLATIONS ONLY. Installing HNW on closed loop system will void warranty and unit will not be eligible for federal tax credit.

General Information

SAFETY

Warnings, cautions and notices appear throughout this manual. Read these items carefully before attempting any installation, service, or troubleshooting of the equipment.

DANGER: Indicates an immediate hazardous situation, which if not avoided will result in death or serious injury. DANGER labels on unit access panels must be observed.

WARNING: Indicates a potentially hazardous situation, which if not avoided could result in death or serious injury.

CAUTION: Indicates a potentially hazardous situation or an unsafe practice, which if not avoided could result in minor or moderate injury or product or property damage.

NOTICE: Notification of installation, operation or maintenance information, which is important, but which is not hazard-related.

WARNING!

WARNING! To avoid the release of refrigerant into the atmosphere, the refrigerant circuit of this unit must be serviced only by technicians who meet local, state, and federal proficiency requirements.

The following warning complies with State of California law, Proposition 65.

WARNING!

WARNING! This product can expose you to chemicals including Carbon Black, which is known to the State of California to cause cancer and Methanol, which is known to the State of California to cause birth defects or other reproductive harm. For more information go to www.P65Warnings.ca.gov

WARNING!

WARNING! All refrigerant discharged from this unit must be recovered **WITHOUT EXCEPTION**. Technicians must follow industry accepted guidelines and all local, state, and federal statutes for the recovery and disposal of refrigerants. If a compressor is removed from this unit, refrigerant circuit oil will remain in the compressor. To avoid leakage of compressor oil, refrigerant lines of the compressor must be sealed after it is removed.

CAUTION!

CAUTION! To avoid equipment damage, **DO NOT** use these units as a source of heating or cooling during the construction process. The mechanical components and filters can quickly become clogged with construction dirt and debris, which may cause system damage and void product warranty.

General Information, Cont'd.

INSPECTION

Upon receipt of the equipment, carefully check the shipment against the bill of lading. Make sure all units have been received. Inspect the carton or crating of each unit, and inspect each unit for damage. Assure the carrier makes proper notation of any shortages or damage on all copies of the freight bill and completes a common carrier inspection report. Concealed damage not discovered during unloading must be reported to the carrier within 15 days of receipt of shipment. **If not filed within 15 days, the freight company can deny the claim without recourse. Note: It is the responsibility of the purchaser to file all necessary claims with the carrier.** Notify the Heat Controller Traffic Department of all damage within fifteen (15) days of shipment.

STORAGE

Equipment should be stored in its original packaging in a clean, dry area. Store units in an upright position at all times. The stack limit for HNW036, 060 and 120 is three.

UNIT PROTECTION

Cover units on the job site with either shipping packaging, vinyl film, or an equivalent protective covering. Cap the open ends of pipes stored on the job site. In areas where painting, plastering, and/or spraying has not been completed, all due precautions must be taken to avoid physical damage to the units and contamination by foreign material. Physical damage and contamination may prevent proper start-up and may result in costly equipment clean-up.

Examine all pipes, fittings, and valves before installing any of the system components. Remove any dirt or trash found in or on these components.

PRE-INSTALLATION

Installation, Operation, and Maintenance instructions are provided with each unit. The installation site chosen should include adequate service clearance around the unit. Before unit start-up, read all manuals and become familiar with the unit and its operation. Thoroughly check the system before operation.

PREPARE UNITS FOR INSTALLATION AS FOLLOWS:

1. Compare the electrical data on the unit nameplate with ordering and shipping information to verify that the correct unit has been shipped.
2. Keep the cabinet covered with the shipping packaging until installation is complete and all plastering, painting, etc. is finished.
3. Verify refrigerant tubing is free of kinks or dents and that it does not touch other unit components.
4. Inspect all electrical connections. Connections must be clean and tight at the terminals.

CAUTION!

CAUTION! DO NOT store or install units in corrosive environments or in locations subject to temperature or humidity extremes (e.g., attics, garages, rooftops, etc.). Corrosive conditions and high temperature or humidity can significantly reduce performance, reliability, and service life. Always move and store units in an upright position. Tilting units on their sides will cause equipment damage.

CAUTION!

CAUTION! CUT HAZARD - Failure to follow this caution may result in personal injury. Sheet metal parts may have sharp edges or burrs. Use care and wear appropriate protective clothing, safety glasses and gloves when handling parts and servicing heat pumps.

Physical Data

Model	036	060	120
Compressor (qty)	Scroll (1)		Scroll (2)
Factory Charge HFC-410A (oz) [kg] Per Circuit	72 [2.04]	96 [2.49]	96 [2.49]
Water Connection Size			
Source/Load	1" Swivel		1-1/2 FPT
HWG (in)	1" Swivel		1/2" FPT
Weight - Operating (lbs) [kg]	348 [158]	360 [163]	726 [329]
Weight - Packaged (lbs) [kg]	373 [169]	385 [175]	770 [349]
Water Volume (Source)			
Gallons (Liters)	0.96 (3.64)	1.33 (5.04)	2.65 (10.02)

Dual isolated compressor mounting
 Balanced port expansion valve (TXV)
 Insulated Source and Load Water Coils standard
 Insulated Refrigerant Circuit standard
 Compressor on (green) and fault (red) light

Dimensional Data

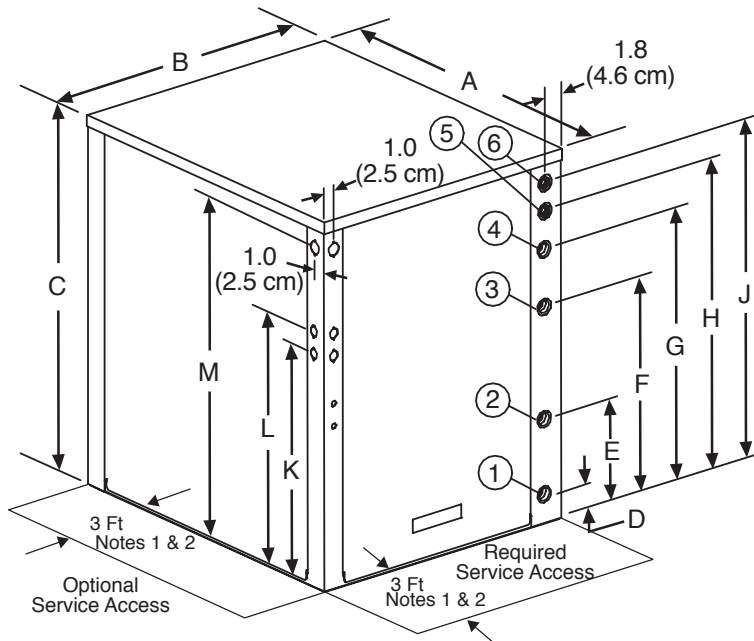

HNW 036, 060

Notes:

1. 3 feet front access is required, both sides access is optional preferred for service access. However, all components may be serviced from the front access panel if side access is not available.
2. While clear access to all removable panels is not required, installer should take care to comply with all building codes and allow adequate clearance for future field services.

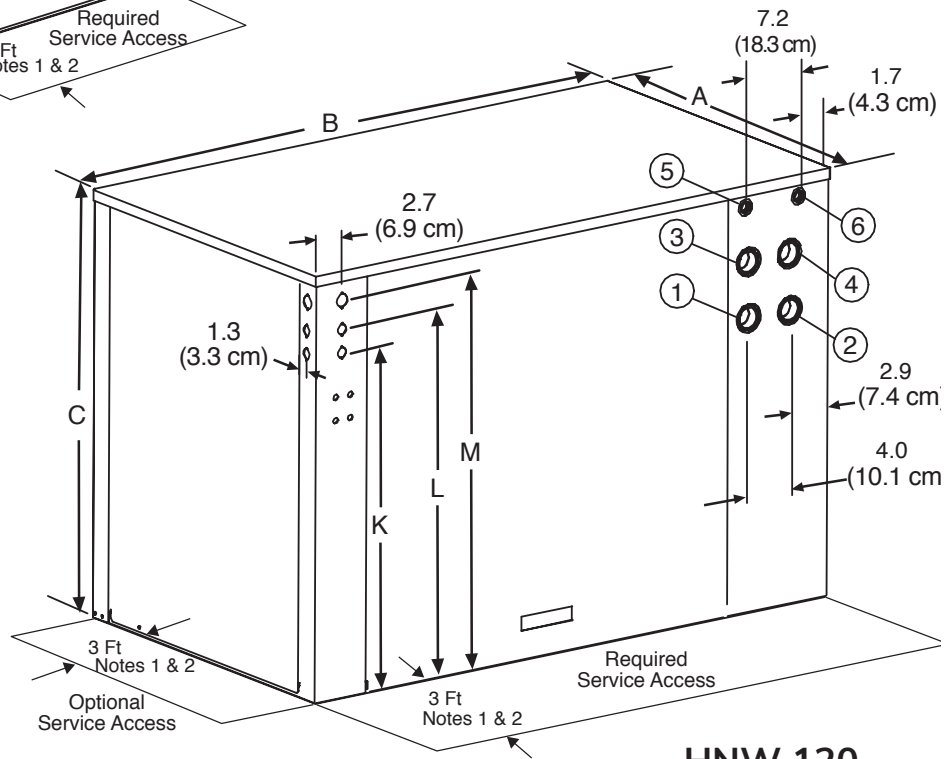

HNW 120

Water to Water	Overall Cabinet			Water Connections						Electric Access Plugs			
	A Depth	B Width	C Height	1	2	3	4	5	6	K Low Voltage	L External Pump	M Power Supply	
				D Source (Outdoor) Water In	E Source (Outdoor) Water Out	F Load (Indoor) Water In	G Load (Indoor) Water Out	H HWG Water In	J HWG Water Out				
036-060	in.	30.6	25.4	33	2.7	9.4	19.4	24.5	27.9	30.4	20.9	22.9	30.9
	cm.	77.8	64.5	83.8	6.9	23.9	49.3	62.2	70.9	77.2	53.1	58.2	78.5
120	in.	30.6	52.9	37	25.2	25.2	30.1	30.1	34.9	34.9	29.9	31.9	34.4
	cm.	77.8	134.4	94	64.0	64.0	76.5	76.5	88.6	88.6	75.9	81.0	87.4

Unit Installation

UNIT LOCATION

These units are not designed for outdoor installation. Locate the unit in an INDOOR area that allows enough space for service personnel to perform typical maintenance or repairs.

The installation of water source heat pump units and all associated components, parts and accessories which make up the installation shall be in accordance with the regulations of ALL authorities having jurisdiction and MUST conform to all applicable codes. It is the responsibility of the Installing Contractor to determine and comply with ALL applicable codes and regulations.

Locate the unit in an indoor area that allows easy removal of access panels, and has enough space for service personnel to perform maintenance or repair. Provide sufficient room to make water and electrical connections. Any access panel screws that would be difficult to remove after the unit is installed should be removed prior to setting the unit. These units are not approved for outdoor installation and, therefore, must be installed inside the structure being conditioned. Do not locate in areas subject to freezing or where humidity levels can cause cabinet condensation.

WATER CONNECTION INSTALLATION

Residential models using swivel piping fittings for water connections are rated for 450 psi (3101 kPa) operating pressure. The connections have a rubber gasket seal similar to a garden hose gasket, which when mated to the flush end of most 1" threaded male pipe fittings provides a leak-free seal without the need for thread sealing tape or joint compound. Insure that the rubber seal is in the swivel connector prior to attempting any connection (rubber seals are shipped attached to the swivel connector). **DO NOT OVERTIGHTEN** or leaks may occur.

FPT CONNECTIONS (SIZE 120)

Pipe joint compound is not necessary when Teflon threaded tape is pre-applied to hose assemblies or when flared-end connections are used. If pipe joint compound is preferred, use compound only in small amounts on the pipe threads of the fitting adapters. Prevent sealant from reaching the flared surfaces of the joint.

NOTE: When antifreeze is used in the loop, assure that it is compatible with Teflon tape or pipe joint compound employed.

Maximum allowable torque for brass fittings is 30 ft-lbs [41 N-m]. If a torque wrench is not available, tighten finger-tight plus one quarter turn. Tighten steel fittings as necessary.

The female locking ring is threaded onto the pipe threads which holds the male pipe end against the rubber gasket, and seals the joint. **HAND TIGHTEN ONLY! DO NOT OVERTIGHTEN!**

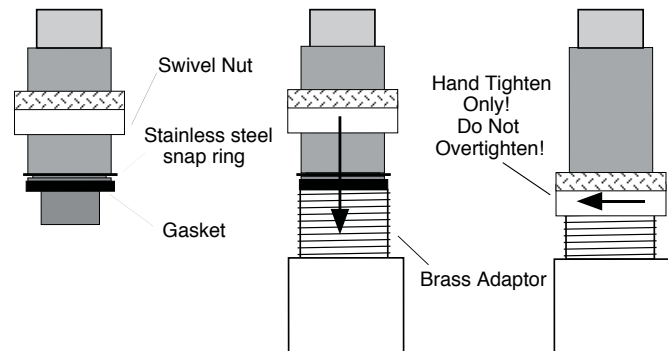

⚠ WARNING! ⚠

WARNING! Polyolester Oil, commonly known as POE oil, is a synthetic oil used in many refrigeration systems including those with HFC-410A refrigerant. POE oil, if it ever comes in contact with PVC or CPVC piping, may cause failure of the PVC/CPVC. PVC/CPVC piping should never be used as supply or return water piping with water source heat pump products containing HFC-410A as system failures and property damage may result.

Ground-Water Heat Pump Applications

OPEN LOOP: GROUND-WATER SYSTEMS

Typical open loop piping is shown in Figure 2. Shut off valves should be included for ease of servicing. Boiler drains or other valves should be “tee’d” into the lines to allow acid flushing of the heat exchanger. Shut off valves should be positioned to allow flow through the coaxial heat exchanger via the boiler drains without allowing flow into the piping system. P/T plugs should be used so that pressure drop and temperature can be measured. Supply and return water piping should be limited to copper, HPDE, or other acceptable high temperature material. Note that PVC or CPVC material is not recommended as they are not compatible with the polyolester oil used in HFC-410A products.

Water quantity should be plentiful and of good quality. Consult water quality table for guidelines. The unit comes standard with either a copper or cupro-nickel source water heat exchanger. Consult Table 1 for recommendations. In conditions anticipating heavy scale formation or in brackish water, a cupro-nickel heat exchanger is recommended. In ground water situations where scaling could be heavy or where biological growth such as iron bacteria will be present, an open loop system is not recommended. Heat exchanger coils may over time lose heat exchange capabilities due to build up of mineral deposits. Heat exchangers must only be serviced by a qualified technician, as acid and special pumping equipment is required. Desuperheater coils can likewise become scaled and possibly plugged. In areas with extremely hard water, the owner should be informed that the heat exchanger may require occasional acid flushing. In some cases, the desuperheater option should not be recommended due to hard water conditions and additional maintenance required.

WATER QUALITY REQUIREMENTS

Scaling potential should be assessed using the pH/ Calcium hardness method. If the pH < 7.5 and the Calcium hardness is less than 100 ppm, scaling potential is low. If this method yields numbers out of range of those listed, the Ryznar Stability and Langelier Saturation indexes should be calculated. Use the appropriate scaling surface temperature for the application, 150°F [66°C] for direct use (well water/ open loop) and HWG (desuperheater); 85°F [29°C] for indirect use. A monitoring plan should be implemented in these probable scaling situations. Other water quality issues such as iron fouling, corrosion prevention and erosion and logging should also be considered.

EXPANSION TANK AND PUMP

Use a closed, bladder-type expansion tank to minimize mineral formation due to air exposure. The expansion tank should be sized to provide at least one minute continuous run time of the pump using its drawdown capacity rating to prevent pump short cycling. Discharge water from the unit is not contaminated in any manner and can be disposed of in various ways, depending on local building codes (e.g.

recharge well, storm sewer, drain field, adjacent stream or pond, etc.). Most local codes forbid the use of sanitary sewer for disposal. Consult your local building and zoning department to assure compliance in your area.

The pump should be sized to handle the home’s domestic water load (typically 5-9 gpm [23-41 l/m]) plus the flow rate required for the heat pump. Pump sizing and expansion tank must be chosen as complimentary items. For example, an expansion tank that is too small can causing premature pump failure due to short cycling. Variable speed pumping applications should be considered for the inherent energy savings and smaller expansion tank requirements.

WATER CONTROL VALVE

Always maintain water pressure in the heat exchanger by placing the water control valve(s) on the discharge line to prevent mineral precipitation during the off-cycle. Pilot operated slow closing valves are recommended to reduce water hammer. If water hammer persists, a mini-expansion tank can be mounted on the piping to help absorb the excess hammer shock. Insure that the total ‘VA’ draw of the valve can be supplied by the unit transformer. For instance, a slow closing valve can draw up to 35VA. This can overload smaller 40 or 50 VA transformers depending on the other controls in the circuit. A typical pilot operated solenoid valve draws approximately 15VA. Note the special wiring diagrams later in this manual for slow closing valves.

FLOW REGULATION

Flow regulation can be accomplished by two methods. One method of flow regulation involves simply adjusting the ball valve or water control valve on the discharge line. Measure the pressure drop through the unit heat exchanger, and determine flow rate from tables located later in this manual. Since the pressure is constantly varying, two pressure gauges may be needed. Adjust the valve until the desired flow of 1.5 to 2 gpm per ton [2.0 to 2.6 l/m per kW] is achieved. A second method of flow control requires a flow control device mounted on the outlet of the water control valve. The device is typically a brass fitting with an orifice of rubber or plastic material that is designed to allow a specified flow rate. On occasion, flow control devices may produce velocity noise that can be reduced by applying some back pressure from the ball valve located on the discharge line. Slightly closing the valve will spread the pressure drop over both devices, lessening the velocity noise. **NOTE: When EWT is below 50°F [10°C], a minimum of 2 gpm per ton (2.6 l/m per kW) is required.**

LOAD WATER COIL LOW TEMPERATURE LIMIT SETTING

For all open loop systems, if the leaving water is below 40°F (4.4°C), must use antifreeze and clip JW2 (factory setting-water) to avoid freeze damage to the unit. See “Low Water Temperature Cutout Selection” in this manual for details on the low limit setting.

Ground-Water Heat Pump Applications, Cont'd.

⚠ CAUTION! ⚠

CAUTION! Many units are installed with a factory or field supplied manual or electric shut-off valve. **DAMAGE WILL OCCUR** if shut-off valve is closed during unit operation. A high pressure switch must be installed on the heat pump side of any field provided shut-off valves and connected to the heat pump controls in series with the built-in refrigerant circuit high pressure switch to disable compressor operation if water pressure exceeds pressure switch setting. The field installed high pressure switch shall have a cut-out pressure of 300 psig and a cut-in pressure of 250 psig. This pressure switch can be ordered from Heat Controller with a 1/4" internal flare connection as part number 39B0005N02.

⚠ CAUTION! ⚠

CAUTION! Refrigerant pressure activated water regulating valves should never be used with Heat Controller equipment.

Figure 2: Typical Open Loop/ Well Application

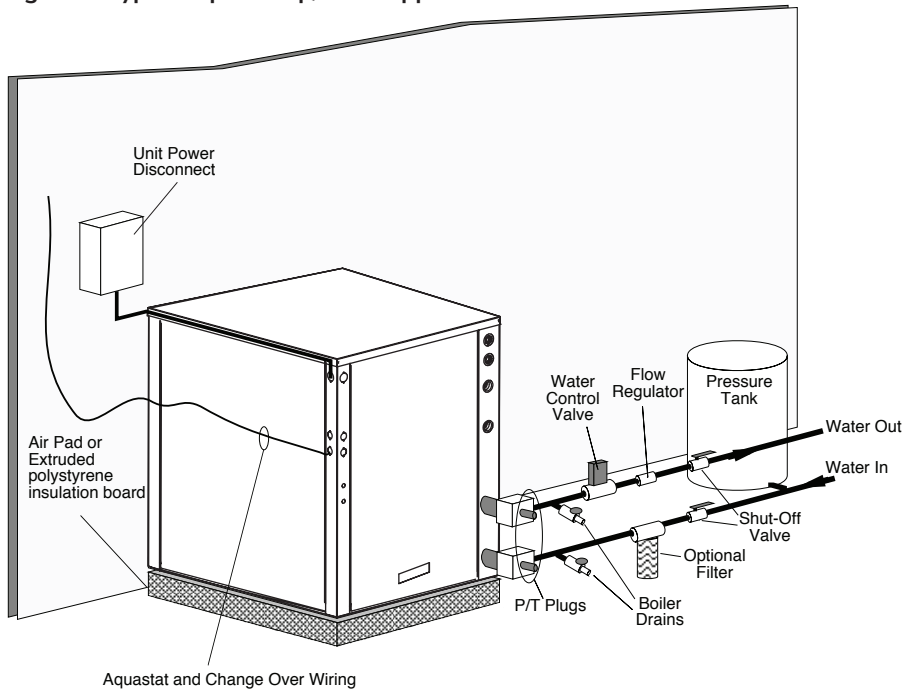

Water Quality Requirements

Table 1: Water Quality Requirements

Clean water is essential to the performance and life span of water source heat pumps. Contaminants, chemicals, and minerals all have the potential to cause damage to the water heat exchanger if not treated properly. All closed water loop systems should undergo water quality testing and be maintained to the water quality requirements listed in this table.

WATER QUALITY REQUIREMENTS							
For Closed-Loop and Open-Loop Systems							
	Description	Symbol	Units	Heat Exchanger Type			
				Closed Loop Recirculating		Open Loop, Tower, Ground Source Well	
				All Heat Exchanger Types	COAXIAL HX Copper Tube in Tube	COAXIAL HX Cupronickel	Brazed Plate HX 316 SS
Scaling Potential	pH - Chilled Water <85°F			7.0 to 9.0	7.0 to 9.0	7.0 to 9.0	7.0 to 9.0
	pH - Heated Water >85°F			8.0 to 10.0	8.0 to 10.0	8.0 to 10.0	8.0 to 10.0
	Alkalinity	(HCO ₃ ⁻)	ppm - CaCO ₃ equiv.	50 to 500	50 to 500	50 to 500	50 to 500
	Calcium	(Ca)	ppm	<100	<100	<100	<100
	Magnesium	(Mg)	ppm	<100	<100	<100	<100
	Total Hardness	(CaCO ₃)	ppm - CaCO ₃ equiv.	30 to 150	150 to 450	150 to 450	150 to 450
	Langelier Saturation Index	LSI		-0.5 to +0.5	-0.5 to +0.5	-0.5 to +0.5	-0.5 to +0.5
Ryznar Stability Index	RSI		6.5 to 8.0	6.5 to 8.0	6.5 to 8.0	6.5 to 8.0	
Corrosion Prevention	Total Dissolved Solids	(TDS)	ppm - CaCO ₃ equiv.	<1000	<1000	<1000	<1500
	Sulfate	(SO ₄ ²⁻)	ppm	<200	<200	<200	<200
	Nitrate	(NO ₃ ⁻)	ppm	<100	<100	<100	<100
	Chlorine (free)	(Cl)	ppm	<0.5	<0.5	<0.5	<0.5
	Chloride (water < 80°F)	(Cl ⁻)	ppm	<20	<20	<150	<150
	Chloride (water > 120°F)	(Cl ⁻)	ppm	<20	<20	<125	<125
	Hydrogen Sulfide ^a	(H ₂ S)	ppb	<0.5	<0.5	<0.5	<0.5
	Carbon Dioxide	(CO ₂)	ppm	0	<50	10 to 50	10 to 50
	Iron Oxide	(Fe)	ppm	<1.0	<1.0	<1.0	<0.2
	Manganese	(Mn)	ppm	< 0.4	<0.4	<0.4	<0.4
	Ammonia	(NH ₃)	ppm	<0.05	<0.1	<0.1	<0.1
	Chloramine	(NH ₂ CL)	ppm	0	0	0	0
	Fouling & Biological	Iron Bacteria		cells/mL	0	0	0
Slime Forming Bacteria			cells/mL	0	0	0	0
Sulfate reducing bacteria			cells/mL	0	0	0	0
Suspended Solids ^b		(TSS)	ppm	<10	<10	<10	<10
Electrolysis All HX types	Earth Ground Resistance ^x		Ohms	0	Consult NEC & local electrical codes for grounding requirements		
	Electrolysis Voltage ⁵		mV	<300	Measure voltage internal water loop to HP ground		
	Leakage Current ⁵		mA	<15	Measure current in water loop pipe		
	Building Primary Electrical Ground to unit, must meet local diameter and penetration length requirements Do not connect heat pump to steel pipe unless dissimilar materials are separated by using Di-electric unions. Galvanic corrosion of heat pump water pipe will occur.						

Water Quality Requirements, Cont'd.

1. The Heat Controller Water Quality Table provides water quality requirements for coaxial & brazed plate heat exchangers.
 2. The water must be evaluated by an independent testing facility comparing site samples against this Table. When water properties are outside of these parameters, the water must either be treated by a professional water treatment specialist to bring the water quality within the boundaries of this specification, or an external secondary heat exchanger must be used to isolate the heat pump water system from the unsuitable water. Failure to do so will void the warranty of the heat pump system and will limit liability for damage caused by leaks or system failure.
 3. Regular sampling, testing and treatment of the water is necessary to assure that the water quality remains within acceptable levels thereby allowing the heat pump to operate at optimum levels.
 4. If closed-loop systems are turned off for extended periods, water samples must be tested prior to operating the system.
 5. For optimal performance, it is recommended that the closed-loop piping systems are initially filled with de-ionized water.
 6. Well water with chemistry outside of these boundaries, and salt water or brackish water requires an external secondary heat exchanger. Surface/Pond water should not be used.
 7. If water temperature is expected to fall below 40°F, antifreeze is required. Refer to the heat pump IOM for the correct solution ratios to prevent freezing.
- α Hydrogen Sulfide has an odor of rotten eggs. If one detects this smell, a test for H₂S must be performed. If H₂S is detected above the limit indicated, remediation is necessary (Consult with your Water Testing/Treatment Professional) or a secondary heat exchanger is required using appropriate materials as recommended by the heat exchanger supplier.
 - β Suspended solids and particulates must be filtered to prevent fouling and failure of heat exchangers. Strainers or particulate filters must be installed to provide a maximum particle size of 600 micron (0.60 mm, 0.023 in.) using a 20 to 30 mesh screen size. When a loop is installed in areas with fine material such as sand or clay, further filtration is required to a maximum of 100 micron. Refer to the Strainer / Filter Sizing Chart to capture the particle sizes encountered on the site.
 - χ An electrical grounding system using a dedicated ground rod meeting NEC and Local Electrical codes must be installed. Building Ground must not be connected to the WSHP piping system or other plumbing pipes.
 - δ Refer to IOM for instructions on measuring resistance and leakage currents within water loops.

Do not use PVC pipe for water loop (compressor POE oil and glycols damage PVC) use of HDPE pipe is recommended.

Strainer / Filter Sizing			
Mesh Size	Particle Size		
	Microns	MM	Inch
20	840	0.840	0.0340
30	533	0.533	0.0210
60	250	0.250	0.0100
100	149	0.149	0.0060
150	100	0.100	0.0040
200	74	0.074	0.0029

ppm = parts per million
ppb = parts per billion

Water Quality Requirements, Cont'd.

Measuring Earth Ground Resistance

Measure the earth ground bond using an Ohm meter between the building's ground rod and the steel well casing.

The resistance measured should be zero Ohms. The NEC allows a resistance to ground up to 20 Ohms. Any resistance above zero, indicates a poor earth ground which may be the result of a hot neutral line or that conductive water is present. Both of these may lead to electrolysis and corrosion of the heat pump piping. A check for both should be performed and resolved.

Note if the well casing is plastic, a conductive path can be achieved by inserting a #6 AWG bare copper wire into the well water. Remove the temporary conductor when finished.

Measuring Electrolysis Voltage and Current

Measure the electrolysis voltage using a volt meter between the heat pump ground and a #14 AWG solid copper wire electrode inserted into the water using a Pete's style access port.

The HP must be operating and the water stream flowing.

The voltage measured should be less than 300mV (0.300 V). If higher than 500mV electrolysis will occur and corrosion will result.

If voltage is measured, the cause is a high resistance earth ground or current on the neutral conductor. Remedial measures should be performed.

Measure the current flowing through the piping system by using an amp clamp probe on the water-in line. The HP must be operating and the water stream flowing.

There should be zero amps measured. If current is present, there is leakage current to the plumbing system and it must be rectified to prevent pipe corrosion.

Load Side Plumbing Installation

HNW UNIT LOAD PLUMBING

The applications are too varied to describe in this document. However, some basic guidelines will be presented. All plumbing should conform to local codes with the following considerations:

Wide temperature variation applications such as heating/cooling coils:

- Employ piping materials that are rated for the maximum temperature and pressure combination. This excludes PVC for most heating applications.
- Insure that load water flow in high temperature heating applications is at least 3 gpm per ton [3.9 l/m per kW] to improve performance and reduce nuisance high pressure faults.
- DO NOT employ plastic to metal threaded joints
- Utilize a pressure tank and air separator vent system to equalize pressure and remove air.

Swimming Pool Hot Tub Applications:

- Load side should be isolated with secondary heat exchanger constructed of anti-corrosion material in all chlorine/bromine fluid applications.

Potable Water Applications:

- Load side should always be isolated with secondary heat exchanger for use in potable water systems.
- Insure load water flow in high temperature heating applications is at least 3 gpm per ton to improve performance and reduce nuisance to high pressure faults.

NOTE: The manufacturer strongly recommends all piping connections, both internal and external to the unit, be pressure tested by an appropriate method prior to any finishing of the interior space or before access to all connections is limited. Test pressure may not exceed the maximum allowable pressure for the unit and all components within the water system. The manufacturer will not be responsible or liable for damages from water leaks due to inadequate or lack of a pressurized leak test, or damages caused by exceeding the maximum pressure rating during installation.

Hot Water Generator

The HWG (Hot Water Generator) or desuperheater option provides considerable operating cost savings by utilizing heat energy from the compressor discharge line to help satisfy domestic hot water requirements. The HWG is active throughout the year, providing virtually free hot water when the heat pump operates in the cooling mode or hot water at the COP of the heat pump during operation in the heating mode. Actual HWG water heating capacities are provided in the appropriate heat pump performance data.

Heat pumps equipped with the HWG option include a built-in water to refrigerant heat exchanger that eliminates the need to tie into the heat pump refrigerant circuit in the field. The control circuit and pump are also built in for residential equipment. Figure 3 shows a typical example of HWG water piping connections on a unit with built-in circulating pump. This piping layout prevents sludge/debris from the bottom of the tank being pulled into the HWG pump.

The temperature setpoint of the HWG is field selectable to 125°F or 150°F. The 150°F setpoint allows more heat storage from the HWG. For example, consider the amount of heat that can be stored by the HWG when using the 125°F setpoint, versus the amount of heat that can be generated by the HWG when using the 150°F setpoint.

In a typical 50 gallon two-element electric water heater the lower element should be turned down to 100°F, or the lowest setting, to get the most from the HWG. The tank will eventually stratify so that the lower 80% of the tank, or 40 gallons, becomes 100°F (controlled by the lower element). The upper 20% of the tank, or 10 gallons, will be maintained at 125°F (controlled by the upper element).

Figure 3: Typical HWG Installation

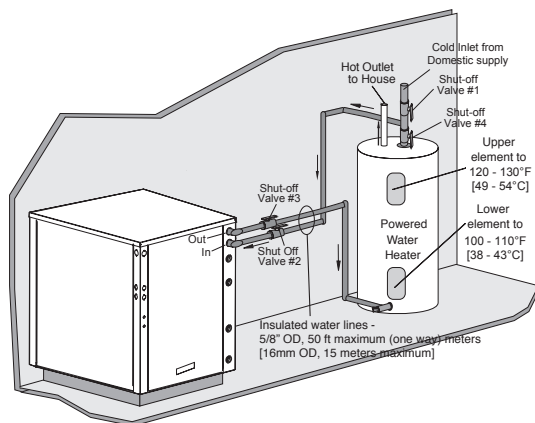

Using a 125°F setpoint, the HWG can heat the lower 40 gallons of water from 100°F to 125°F, providing up to 8,330 btu's of heat. Using the 150°F setpoint, the HWG can heat the same 40 gallons of water from 100°F to 150°F and the remaining 10 gallons of water from 125°F to 150°F, providing a total of up to 18,743 btu's of heat, or more than twice as much heat as when using the 125°F setpoint.

Electric water heaters are recommended. If a gas, propane, or oil water heater is used, a second preheat tank must be installed (Figure 4). If the electric water heater has only a single center element, the dual tank system is recommended to insure a usable entering water temperature for the HWG.

Typically a single tank of at least 50 gallons (189 liters) is used to limit installation costs and space. However, a dual tank, as shown in Figure 4, is the preferred system, as it provides the maximum storage and temperate source water to the HWG.

It is always advisable to use water softening equipment on domestic water systems to reduce the scaling potential and lengthen equipment life. In extreme water conditions, it may be necessary to avoid the use of the HWG option since the potential cost of frequent maintenance may offset or exceed any savings. Consult Table 1 for scaling potential tests.

⚠ WARNING! ⚠

WARNING! A 150°F setpoint may lead to scalding or burns. The 150°F setpoint must only be used on systems that employ an approved anti-scald valve.

Figure 4: HWG Double Tank Installation

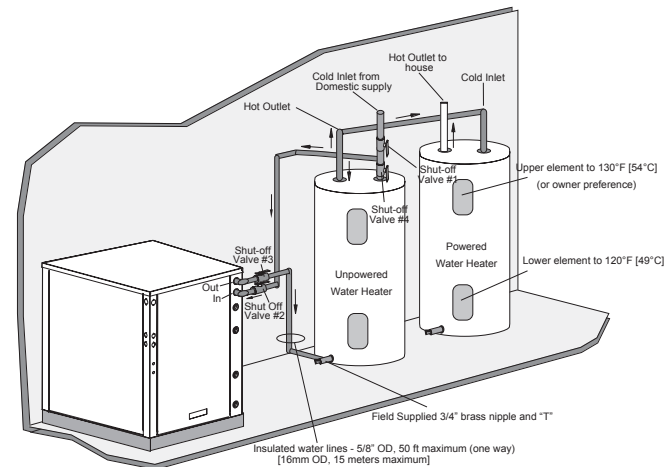

Hot Water Generator, Cont'd.

INSTALLATION

The HWG is controlled by two sensors and the DXM2.5 microprocessor control. One sensor is located on the compressor discharge line to sense the discharge refrigerant temperature. The other sensor is located on the HWG heat exchanger's "Water In" line to sense the potable water temperature.

⚠ WARNING! ⚠

WARNING! Under no circumstances should the sensors be disconnected or removed. Full load conditions can drive hot water tank temperatures far above safe temperature levels if sensors are disconnected or removed.

The DXM2.5 microprocessor control monitors the refrigerant and water temperatures to determine when to operate the HWG. The HWG will operate any time the refrigerant temperature is sufficiently above the water temperature. Once the HWG has satisfied the water heating demand during a heat pump run cycle, the controller will cycle the pump at regular intervals to determine if an additional HWG cycle can be utilized.

When the control is powered and the HWG pump output is active for water temperature sampling or HWG operation, the DXM2.5 status LED will slowly flash (On 1 second, Off 1 second).

If the control has detected a HWG fault, the DXM2.5 status LED will flash a numeric fault code as follows:

High Water Temperature (> 160°F)	5 flashes
Hot Water Sensor Fault	6 flashes
Compressor Discharge Sensor Fault	6 flashes

Fault code flashes have a duration of 0.3 seconds with a 10 second pause between fault codes. For example, a "Compressor Discharge Sensor Fault" will be six flashes 0.3 seconds long, then a 10 second pause, then six flashes again, etc.

⚠ WARNING! ⚠

WARNING! Using 150°F setpoint on the HWG will result in water temperatures sufficient to cause severe physical injury in the form of scalding or burns, even when the hot water tank temperature setting is visibly set below 150°F. The 150°F HWG setpoint must only be used on systems that employ an approved anti-scald valve (part number AVAS4) at the hot water storage tank with such valve properly set to control water temperatures distributed to all hot water outlets at a temperature level that prevents scalding or burns.

Figure 5: Anti-Scald Valve Piping Connections

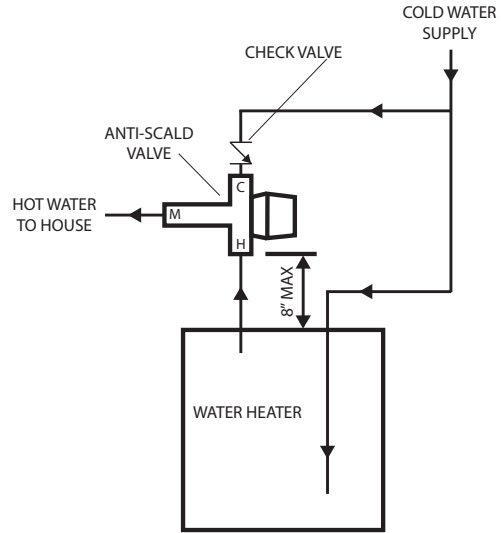

Hot Water Generator settings are determined by DIP switches 3-2, 3-3, and 3-4.

DIP 3-2 controls the HWG Test Mode. It provides for forced operation of the HWG output, activating the HWG pump for up to five minutes.

ON = HWG test mode, OFF = normal HWG operation.

The control will revert to standard operation after five minutes regardless of switch position.

DIP 3-3 determines HWG setpoint temperature. It provides for selection of the HWG operating setpoint.

ON = 150°F (66°C), OFF = 125°F (52°C).

DIP 3-4 is for the HWG status. It provides HWG operation control.

ON = HWG mode enabled, OFF = HWG mode disabled.

Units are shipped from the factory with this switch in the OFF position.

Figure 6: Hot Water Generator Settings

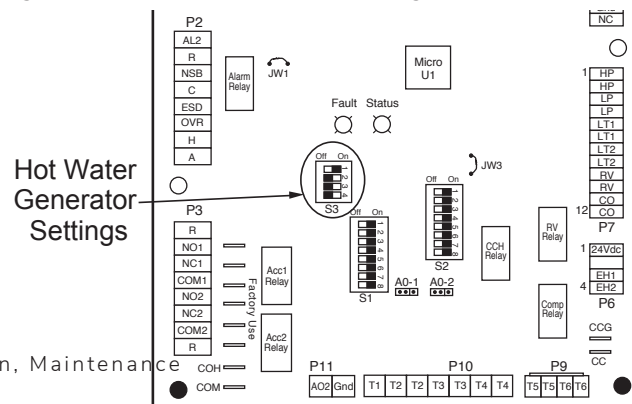

Hot Water Generator, Cont'd.

WARNING!

WARNING! The HWG pump is fully wired from the factory. Use extreme caution when working around the microprocessor control as it contains line voltage connections that presents a shock hazard that can cause severe injury or death.

The heat pump, water piping, pump, and hot water tank should be located where the ambient temperature does not fall below 50°F [10°C]. Keep water piping lengths at a minimum. DO NOT use a one way length greater than 50 ft. (one way) [15 m]. See Table 2 for recommended piping sizes and maximum lengths.

All installations must be in accordance with local codes. The installer is responsible for knowing the local requirements, and for performing the installation accordingly. DO NOT activate the HWG (turn DIP 3-4 to the ON position) until "Initial Start-Up" section, below is completed. Powering the pump before all installation steps are completed will damage the pump.

WATER TANK PREPARATION

1. Turn off power or fuel supply to the hot water tank.
2. Connect a hose to the drain valve on the water tank.
3. Shut off the cold water supply to the water tank.
4. Open the drain valve and open the pressure relief valve or a hot water faucet to drain tank.
5. When using an existing tank, it should be flushed with cold water after it is drained until the water leaving the drain hose is clear and free of sediment.
6. Close all valves and remove the drain hose.
7. Install HWG water piping.

HWG WATER PIPING

1. Using at least 1/2" [12.7 mm] I.D. copper, route and install the water piping and valves as shown in Figures 21 or 22. Install an approved anti-scald valve if the 150°F HWG setpoint is or will be selected. An appropriate method must be employed to purge air from the HWG piping. This may be accomplished by flushing water through the HWG (as in Figures 21 and 22) or by installing an air vent at the high point of the HWG piping system.
2. Insulate all HWG water piping with no less than 3/8 inches [10 mm] wall closed cell insulation.
3. Open both shut off valves and make sure the tank drain valve is closed.

WATER TANK REFILL

1. Close valve #4. Ensure that the HWG valves (valves #2 and #3) are open. Open the cold water supply (valve #1) to fill the tank through the HWG piping. This will force water flow through the HWG and purge air from the HWG piping.
2. Open a hot water faucet to vent air from the system until water flows from faucet; turn off faucet. Open valve #4.
3. Depress the hot water tank pressure relief valve handle

- to ensure that there is no air remaining in the tank.
4. Inspect all work for leaks.
5. Before restoring power or fuel supply to the water heater, adjust the temperature setting on the tank thermostat(s) to insure maximum utilization of the heat available from the refrigeration system and conserve the most energy. On tanks with both upper and lower elements and thermostats, the lower element should be turned down to 100°F [38°C] or the lowest setting; the upper element should be adjusted to 120-130°F [49-54°C]. Depending upon the specific needs of the customer, you may want to adjust the upper element differently. On tanks with a single thermostat, a preheat tank should be used (Figure 4).
6. Replace access cover(s) and restore power or fuel supply.

INITIAL START-UP

1. Make sure all valves in the HWG water circuit are fully open.
2. Turn on the heat pump and allow it to run for 10-15 minutes.
3. Set S3-4 to the "ON" position (enabled) to engage the HWG. See Figure 6.
4. The HWG pump should not run if the compressor is not running.
5. The temperature difference between the water entering and leaving the HWG coil should be approximately 5-10°F [3-6°C].
6. Allow the unit to operate for 20 to 30 minutes to insure that it is functioning properly.

Table 2: HWG Water Piping Sizes and Length

Unit Nominal Tonnage	Nominal HWG Flow (gpm)	1/2" Copper (max length*)	3/4" Copper (max length*)
2.0	0.8	50	-
2.5	1.0	50	-
3.0	1.2	50	-
3.5	1.4	50	-
4.0	1.6	45	50
5.0	2.0	25	50
6.0	2.4	10	50

*Maximum length is equivalent length (in feet) one way of type L copper.

CAUTION!

CAUTION! Use only copper piping for HWG piping due to the potential of high water temperatures for water that has been in the HWG heat exchanger during periods of no-flow conditions (HWG pump not energized). Piping other than copper may rupture due to high water temperature and potable water pressure. CPVC, PEX, or other plastic pipe should not be used HWG piping

Electrical – Line Voltage

⚠ CAUTION! ⚠
CAUTION! Use only copper conductors for field installed electrical wiring. Unit terminals are not designed to accept other types of conductors.

GENERAL LINE VOLTAGE WIRING

Be sure the available power is the same voltage and phase as that shown on the unit serial plate. Line and low voltage wiring must be done in accordance with local codes or the National Electric Code, whichever is applicable.

POWER CONNECTION

Line voltage connection is made by connecting the incoming line voltage wires to the power distribution block, or compressor contactor, refer to unit wiring diagram. Consult the electrical data table (Table 3) for correct fuse size.

TRANSFORMER

The units are factory wired for 230 Volt. If supply voltage is 208V, transformer must be rewired by installer as illustrated on the wiring diagram by switching the Red (208V) and the Orange (230V) at the contactor terminal L1.

LOAD AND SOURCE PUMPS

Wire pumps to unit per unit wire diagram.

⚠ WARNING! ⚠
WARNING! Disconnect electrical power source to prevent injury or death from electrical shock.

⚠ WARNING! ⚠
WARNING! To avoid possible injury or death due to electrical shock, open the power supply disconnect switch and secure it in an open position during installation.

All field installed wiring, including electrical ground, must comply with the National Electrical Code as well as all applicable local codes.

Refer to the unit wiring diagrams and electrical data table (Table 3) for fuse sizes and a schematic of the field connections which must be made by the installing (or electrical) contractor.

Consult the unit wiring diagram located on the inside of the compressor access panel to ensure proper electrical hookup. All final electrical connections must be made with a length of flexible conduit to minimize vibration and sound transmission to the building.

Table 3: HNW Electrical Data

Model	Voltage Code	Voltage	Min/Max Voltage	Compressor			HWG Pump FLA	EXT Loop Pump FLA	Total Unit FLA	Min Circuit Amps	Max Fuse/HACR
				RLA	LRA	QTY					
036	3	208/230/60/1	197/252	16.7	79.0	1	0.5	4.0	21.2	25.3	40
060	3	208/230/60/1	197/252	26.3	134.0	1	0.5	4.0	30.8	37.3	60
120	3	208/230/60/1	197/252	26.3	134.0	2	0.5	4.0	57.1	63.6	80

HACR circuit breaker in USA only
 Residential units come standard with 75VA transformer, and optional HWG pump.

Electrical – Low Voltage Wiring

Unit is typically controlled by field installed and wired aquastat and mode changeover switch (R to O is cooling mode). Wire to DXM2.5 P1 terminals, use minimum 18GA Class II wire.

NOTE: Do not close up unit until checkout is completed.

WATER SOLENOID VALVES

An external solenoid valve(s) (with end switch so valve is fully open before compressor starts) should be used. Valve should also be normally closed type so water flows through only when unit is operating. A slow closing valve may be required to help reduce water hammer. Typical wiring for a 24VAC external solenoid valve. Figures 5 or 6 illustrate typical slow closing water control valve wiring for Taco zone sentry series (Heat Controller P/N AMV...) and Taco SBV series valves. Slow closing valves take approximately 60 seconds to open (very little water will flow before 45 seconds). Once fully open, an end switch closure allows the compressor to be energized. When wired as shown, the slow closing valve will operate properly with the following notations:

1. The valve will remain open during a unit lockout.
2. The valve will draw approximately 25-35 VA through the “Y” signal of the aquastat

Figure 7: Accessory Motorized Water Valve - Typical Wiring Example #1

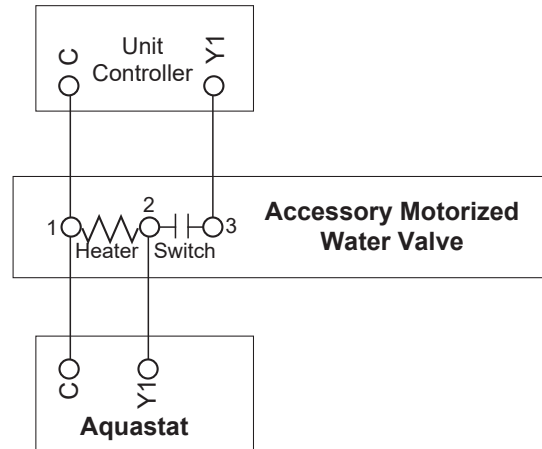
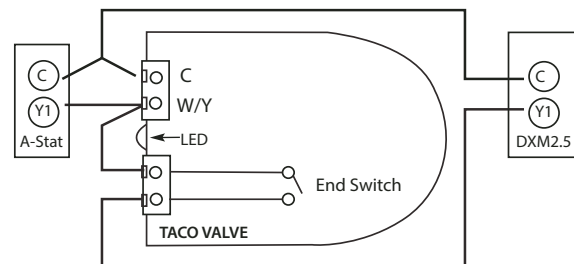

Figure 8: Accessory Motorized Water Valve - Typical Wiring Example #2



Controls – DXM2.5



DXM2.5 CONTROLS

For detailed controller information, see the DXM2.5 Application, Operation, and Maintenance (AOM) manual (part # 97B0142N01).

Unit Commissioning & Operating Limits

ENVIRONMENT

This unit is designed for indoor installation only. Do not install in an area subject to freezing or where humidity levels can cause cabinet condensation.

POWER SUPPLY

A voltage variation of +/- 10% of nameplate utilization voltage is acceptable.

Operation and performance is primarily dependent upon water temperatures, water flow rates and ambient air temperature. This water-to-water heat pump is capable of operating over a wide temperature range and with flow rates of between 1.5 GPM (.1 l/s) and 3 GPM (.19 l/s) per ton, however usually no more than one of these factors may be at a minimum or maximum level at a time.

THE COMMISSIONING TABLE indicates water temperatures which are suitable for initial unit commissioning in an environment where the flow rate and water temperature is not yet stable and to avoid nuisance shut down of the units freeze and refrigerant pressure safeties.

THE OPERATING TABLE indicates the maximum and minimum ranges of the unit.

For more specific unit performance, reference the product catalog, the submittal data sheets or contact your supplier for assistance.

Table 4

BUILDING COMMISSIONING				
	Cooling		Heating	
Unit Size	036	060/120	036	060/120
Source	50/80°F	50/80°F	50/80°F	50/80°F
Min/Max	10/27°C	10/27°C	10/27°C	10/27°C
Load	60/80°F	60/90°F	60/120°F	60/120°F
Min/Max	16/27°C	16/32°C	16/49°C	16/49°C
Ambient	45/110°F		39/85°F	
Min/Max	7/43°C		4/29°C	

BUILDING OPERATING				
	COOLING		HEATING	
Unit Size	036	060/120	036	060/120
Source	50/80°F	50/80°F	50/80°F	50/80°F
Min/Max	10/27°C	10/27°C	10/27°C	10/27°C
Load	60/80°F	60/90°F	60/120°F	60/120°F
Min/Max	16/27°C	16/32°C	16/49°C	16/49°C
Ambient	45/110°F		39/85°F	
Min/Max	7/43°C		4/29°C	

Unit & System Checkout

WARNING!

WARNING! Verify ALL water controls are open and allow water flow prior to engaging the compressor. Freezing of the heat exchanger or water lines can permanently damage the heat pump.

NOTE: The manufacturer strongly recommends all piping connections, both internal and external to the unit, be pressure tested by an appropriate method prior to any finishing of the interior space or before access to all connections is limited. Test pressure may not exceed the maximum allowable pressure for the unit and all components within the water system. The manufacturer will not be responsible or liable for damages from water leaks due to inadequate or lack of a pressurized leak test, or damages caused by exceeding the maximum pressure rating during installation.

BEFORE POWERING SYSTEM, please check the following:

UNIT CHECKOUT

- Balancing/Shutoff Valves:** Ensure all isolation valves are open, water control valves wired and open, and flow switch (load and source) are operational or brazed plates may burst.
- Line Voltage and Wiring:** Ensure Voltage is within an acceptable range for the unit and wiring and fuses/breakers are properly sized. Low voltage wiring is complete.
- Unit Control Transformer:** Ensure transformer has properly selected control voltage tap. 208-230V units are factory wired for 230 operation unless specified otherwise.
- Entering Water:** Ensure entering water temperatures are within operating limits of Table 4.
- Low Water Temperature Cutout:** Verify low water temperature cut-out on DXM2.5 is properly set.
- Water Flow Balancing:** Verify inlet and outlet water temperatures on both load and source are recorded for each heat pump upon startup. This check can eliminate nuisance trip outs and high velocity water flows that can erode heat exchangers.
- Unit Controls:** Verify DXM2.5 settings are proper and complete.

SYSTEM CHECKOUT

- System Water Temperature:** Check load and source water temperature for proper range and also verify heating and cooling setpoints for proper operation.
- System pH:** Load water pH is 6 - 8.5. Proper pH promotes longevity of hoses and fittings.
- System Flushing:** Verify all hoses are connected end to end when flushing to ensure debris bypasses unit heat exchanger and water valves etc. Water used in the system must be potable quality initially and clean of dirt, piping slag, and strong chemical cleaning agents. Verify all air is purged from the system. Air in the system can cause poor operation or system corrosion.
- Cooling Tower/Boiler:** Check equipment for proper setpoints and operation.
- Standby Pumps:** Verify the standby pump is properly installed and in operating condition.
- System Controls:** Verify system controls function and operate in the proper sequence.
- Low Water Temperature Cutout:** Verify low water temperature cut-out controls are provided for the outdoor portion of the loop or operating problems will occur.
- System Control Center:** Verify control center and alarm panel for proper setpoints and operation.
- Units with HWG:** Confirm hot water tank(s) and piping have been filled and air has been purged. HWG is de-energized (DIP Switch 12 is "On") unit start up.
- Miscellaneous:** Note any questionable aspects of the installation.

WARNING!

WARNING! To avoid equipment damage, DO NOT leave system filled in a building without heat during the winter unless antifreeze is added to system water. Condenser coils never fully drain by themselves and will freeze unless winterized with antifreeze.

Unit Start Up Procedure

⚠ WARNING! ⚠

WARNING! When the disconnect switch is closed, high voltage is present in some areas of the electrical panel. Exercise caution when working with energized equipment.

1. Adjust all valves to their full open position. Turn on the line power to all heat pump units.
2. Source and Load water temperatures should be within the minimum-maximum ranges of Table 4.
3. It is recommended that water-to-water units be first started in the heating mode, when possible. This will allow liquid refrigerant to flow through the filter-drier before entering the TXV, allowing the filter-drier to catch any debris that might be in the system before it reaches the TXV.
4. Four factors determine the operating limits of water source heat pumps, (a) source entering water temperature, (b) source entering water flow rate, (c) load entering water temperature, and (d) load entering water flow rate. When any one of these factors is at a minimum or maximum level, the other factors must be at normal levels to ensure proper unit operation.
 - a. Place the mode switch (if applicable) in the "HEAT" position. Adjust the unit aquastat to the lowest setting.
 - b. Slowly raise the aquastat setting to a higher temperature until the compressor activates.
 - c. Check for warm load water delivery within a few minutes after the unit has begun to operate.
 - d. Verify correct water flow by comparing unit pressure drop across the heat exchanger versus the data in Table 6. Refer to Table 5. Check the temperature of both entering and leaving source water. If the temperature drop is within range, proceed with the test. If the temperature drop is outside of the operating range, check refrigerant pressures and compare to Tables 7 and 8. Heat of extraction (HE) can be calculated for the source and compared to submittal data capacity pages. The formula for HE for systems with water is as follows:

$$HE = TD \times GPM \times 500,$$
 where TD is the temperature difference between the entering and leaving source water, and GPM is the flow rate in U.S. GPM, determined by comparing the pressure drop across the heat exchanger to Table 6.

Table 5: Water Temperature Change Through Source Heat Exchanger

Water Flow, gpm [l/m]	Rise, Cooling °F, [°C]	Drop, Heating °F, [°C]
For Open Loop: Ground Water Systems at 1.5 gpm per ton [2.0 l/m per kW]	20 - 26 [11.1 - 14.4]	10 - 17 [5.6 - 9.4]

Table 6: Water Pressure Drop HNW036-120

Model	GPM	Temperature		
		50°F	70°F	90°F
SOURCE/OUTDOOR COAX HX				
036	4.5	1.3	1.0	0.8
	6.8	3.4	2.8	2.4
	9.0	6.0	5.1	4.5
060	7.5	1.3	1.1	0.9
	11.3	3.4	3.0	2.7
	15.0	6.2	5.5	5.0
120	15.0	1.4	1.2	0.9
	22.5	3.8	3.3	2.7
	30.0	6.8	6.1	5.0
LOAD/INDOOR COAX HX				
036	4.5	0.6	0.5	0.3
	6.8	1.4	1.3	1.1
	9.0	2.6	2.4	2.2
060	7.5	1.4	1.3	1.2
	11.3	3.5	3.2	3.0
	15.0	6.2	5.8	5.5
120	15.0	1.6	1.4	1.3
	22.5	3.8	3.5	3.3
	30.0	6.8	6.4	6.0

Must use antifreeze if operation falls in grey area
Multiply PSI x 2.31 to determine ft of hd

NOTE: Units have a five minute time delay in the control circuit that can be eliminated on the DXM2.5 PCB as shown in Figure 9. See controls description for detailed features of the control.

Figure 9: Test Mode Button

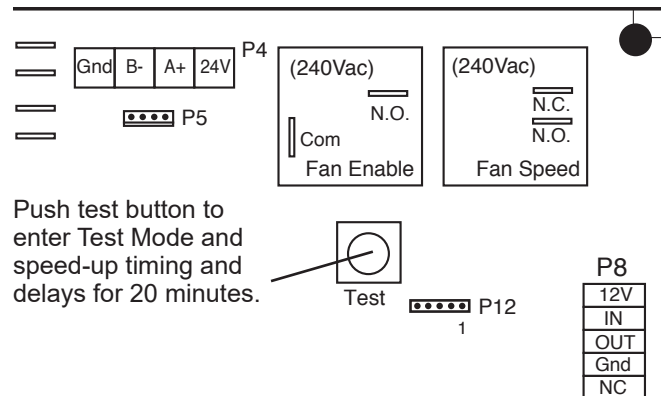

- e. Heating capacity, also known as heat of rejection (HR), can be calculated and compared to submittal data capacity pages. The formula for HR for systems with water is as follows:

$$HR = TD \times GPM \times 500,$$
 where TD is the temperature difference between the entering and leaving load water, and GPM is the flow rate in U.S. GPM, determined by comparing the pressure drop across the heat exchanger to Table 6.
- f. Check for vibration, noise, and water leaks.

Unit Start Up Procedure, Cont'd.

WARNING!

WARNING! Verify ALL water controls are open and allow water flow prior to engaging the compressor. Freezing of the heat exchanger or water lines can permanently damage the heat pump.

5. Allow five (5) minutes between tests for pressure to equalize before beginning cooling test.
 - a. Place the mode switch (if applicable) in the "COOL" position. Adjust the unit aquastat to the highest setting.
 - b. Slowly lower the aquastat setting to a lower temperature until the compressor activates.
 - c. Check for cool load water delivery within a few minutes after the unit has begun to operate.
 - d. Verify correct water flow by comparing unit pressure drop across the heat exchanger versus the data in Table 6. Refer to Table 5. Check the temperature of both entering and leaving source water. If the temperature rise is within range, proceed with the test. If the temperature rise is outside of the operating range, check refrigerant pressures and compare Tables 7 and 8. Heat of rejection (HR) can be calculated for the source and compared to submittal data capacity pages. The formula for HR for systems with water is as follows:

$$HR = TD \times GPM \times 500,$$
 where TD is the temperature difference between the entering and leaving source water, and GPM is the flow rate in U.S. GPM, determined by comparing the pressure drop across the heat exchanger to Table 6.
 - e. Cooling capacity, also known as heat of extraction (HE), can be calculated and compared to submittal data capacity pages. The formula for HE for systems with water is as follows:

$$HE = TD \times GPM \times 500,$$
 where TD is the temperature difference between the entering and leaving load water, and GPM is the flow rate in U.S. GPM, determined by comparing the pressure drop across the heat exchanger to Table 6.
 - f. Check for vibration, noise, and water leaks.
6. If unit fails to operate, perform troubleshooting analysis (see troubleshooting section). If the check described fails to reveal the problem and the unit still does not operate, contact a trained service technician to ensure proper diagnosis and repair of the equipment.
7. When testing is complete, set system to maintain desired comfort level.
8. BE CERTAIN TO FILL OUT AND RETURN ALL WARRANTY REGISTRATION PAPERWORK.

Operating Pressures

Table 7

036-120 (120 Per Circuit) (60 Hz I-P Units)									
Source Entering Water Temp °F	Source Water Flow GPM/ton	Cooling						Water Temp Rise °F Source	Water Temp Drop °F Load
		Load EWT °F @ 1.5-3.0 GPM/ton	Suction Pressure PSIG	Discharge Pressure PSIG	Superheat °F	Subcooling °F			
50	1.5	50	99-106	230-234	11-18	18-25	20-28	7-15	
		60	111-122	241-243	11-18	18-25		8-17	
		70	122-137	251-253	17-25	18-25		8-19	
		80	126-145	254-258	26-35	18-25		9-20	
	2.3	50	98-105	212-214	18-23	14-20	13-18	7-15	
		60	106-117	218-220	18-23	14-20		8-17	
		70	114-129	225-227	24-32	14-20		9-19	
		80	117-135	228-230	32-41	14-20		9-20	
	3.0	50	87-101	199-203	12-18	12-18	9-12	8-16	
		60	91-113	203-207	12-18	12-18		8-17	
		70	95-124	204-216	16-34	12-18		9-19	
		80	107-128	212-217	33-35	12-18		9-20	
80	1.5	50	104-111	343-348	9-14	18-25	19-28	7-14	
		60	121-132	355-360	9-14	18-25		7-16	
		70	138-152	367-373	9-14	18-25		8-18	
		80	148-161	377-381	12-23	18-25		9-20	
	2.3	50	103-111	320-325	8-14	14-21	13-18	7-14	
		60	118-129	328-334	8-14	14-21		8-16	
		70	132-147	336-344	12-20	14-21		8-18	
		80	140-172	343-353	19-29	14-21		9-20	
	3.0	50	94-110	305-314	9-13	12-18	8-12	7-15	
		60	112-121	313-319	9-13	12-18		8-16	
		70	121-146	317-329	12-20	12-18		9-18	
		80	131-151	324-333	18-27	12-18		9-20	

Operating Pressures, Cont'd.

Table 8

036-120 (120 Per Circuit) (60 Hz I-P Units)								
Source Entering Water Temp °F	Source Water Flow GPM/ton	Heating						
		Load EWT °F @ 1.5-3.0 GPM/ton	Suction Pressure PSIG	Discharge Pressure PSIG	Superheat °F	Subcooling °F	Water Temp Drop °F Source	Water Temp Rise °F Load
50	1.5	60	85-95	212-224	6-11	7-11	9-16	6-17
		80	91-99	290-310	6-11	7-11		6-17
		90	92-101	326-338	6-11	7-11		6-17
		100	96-103	381-399	6-11	7-11		5-17
		120	100-108	474-488	6-11	7-11		4-16
	2.3	60	95-102	215-228	6-13	7-11	6-12	7-18
		80	98-106	299-313	6-13	7-11		6-18
		90	99-108	329-341	6-13	7-11		6-18
		100	102-110	384-401	6-13	7-11		6-17
		120	106-114	475-491	6-13	7-11		5-17
	3.0	60	95-107	215-256	6-14	7-15	5-9	7-19
		80	101-110	310-326	6-14	7-15		7-19
		90	103-112	329-376	6-14	7-15		6-19
		100	105-114	399-414	6-14	7-15		6-18
		120	108-118	476-524	6-14	7-15		5-17
80	1.5	60	109-129	225-237	14-26	5-14	15-21	8-18
		80	123-138	314-327	14-26	5-14		8-19
		90	130-142	343-357	10-15	5-14		7-19
		100	137-147	402-415	10-15	5-14		7-19
		120	150-157	493-504	10-15	5-14		6-20
	2.3	60	111-132	227-239	14-38	6-15	10-15	8-20
		80	135-147	315-330	14-38	6-15		8-20
		90	143-152	344-360	10-16	6-15		8-20
		100	145-154	405-418	10-16	6-15		7-20
		120	156-163	494-507	10-16	6-15		6-20
	3.0	60	110-149	227-279	19-44	6-18	7-12	9-21
		80	135-150	286-332	19-44	6-18		8-21
		90	145-166	345-408	13-23	6-18		8-21
		100	148-158	405-420	13-23	6-18		8-21

Preventative Maintenance

LOAD WATER COIL MAINTENANCE

Generally water coil maintenance is not needed for closed loop systems. However, if the piping is known to have high dirt or debris content, it is best to establish a periodic maintenance schedule with the owner so the water coil can be checked regularly. Dirty installations are typically the result of deterioration of iron or galvanized piping or components in the system. Open cooling towers requiring heavy chemical treatment and mineral buildup through water use can also contribute to higher maintenance. Should periodic coil cleaning be necessary, use standard coil cleaning procedures, which are compatible with both the heat exchanger material and copper water lines. Generally, the more water flowing through the unit, the less chance for scaling. However, flow rates over 3 gpm per ton (3.9 l/m per kW) can produce water (or debris) velocities that can erode the heat exchanger wall and ultimately produce leaks.

SOURCE WATER COIL MAINTENANCE

Open loop systems require periodic cleaning to remove scaling. Use standard cleaning procedures which are compatible with cupro-nickel and copper.

HOT WATER GENERATOR COILS

See water coil maintenance for load water coil. If the potable water is hard or not chemically softened, the high temperatures of the desuperheater will tend to scale even quicker than the water coil and may need more frequent inspections. In areas with extremely hard water, a HWG is not recommended.

COMPRESSORS

Conduct annual amperage checks to ensure amp draw is no more than 10% greater than that indicated by serial plate data.

CABINET

Do not allow water to stay in contact with the cabinet for long periods of time to prevent corrosion of the cabinet sheet metal. Generally cabinets are set up from the floor a few inches for prevention. The cabinet can be cleaned using a mild detergent.

REFRIGERANT SYSTEM

To maintain sealed circuit integrity, do not install service gauges unless unit operation appears abnormal. Reference the operating chart for pressure and temperatures. Verify that air and water flow rates are at proper levels before servicing the refrigerant circuit.

If the refrigerant circuit is opened for any reason, a new liquid line filter-drier must be installed.

Troubleshooting Form

Water-to-Water (Heating and Cooling) Troubleshooting Form

Customer: _____ Loop Type: _____ Startup Date: _____

Model #: _____ Serial #: _____ Antifreeze Type & %: _____

Complaint: _____

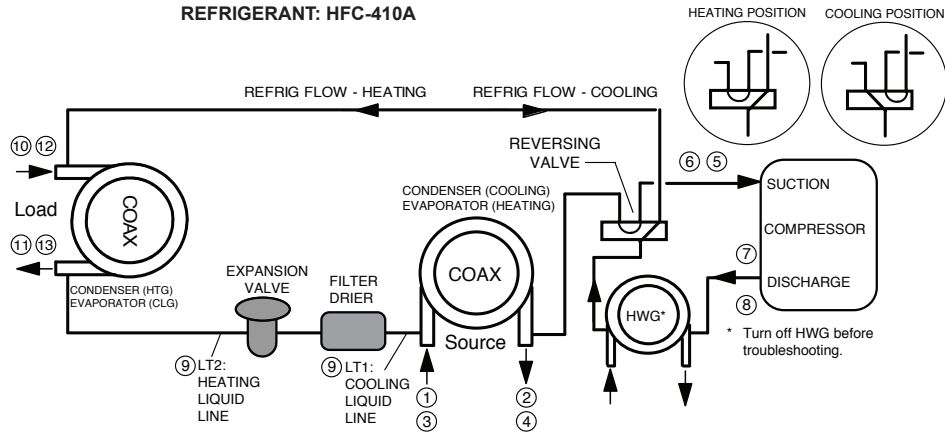

Description		Heating	Cooling	Notes	
Water Side Analysis					
1	Source Water In Temp.				
2	Source Water Out Temp.			H Temp. Diff. =	C Temp. Diff. =
3	Source Water In Pressure				
4	Source Water Out Pressure				
4a	Pressure Drop				
4b	GPM				
Heat of Extraction (Absorption) or Heat of Rejection:				Fluid Factor: 500 (Water); 485 (Antifreeze)	
HE or HR (Btuh) = _____		Enter HE or HR: _____			
_____ Flow Rate (GPM) x _____		Temp. Diff (deg F) x _____		Fluid Factor	
Refrigerant Analysis					
5	Suction Temp.				
6	Suction Pressure				
6a	Saturation Temp.				
6b	Superheat				
7	Discharge Temp.				
8	Discharge Pressure				
8a	Saturation Temp.				
8b	Subcooling				
9	Liquid Line Temp				
10	Load Water In Temp.				
11	Load Water Out Temp.			H Temp. Diff. =	C Temp. Diff. =
12	Load Water In Pressure				
13	Load Water Out Pressure				
13a	Pressure Drop				
13b	GPM				
	Voltage	Installation, Operation, Maintenance			
	Compress Amps				



LIMITED EXPRESS WARRANTY

Congratulations on purchasing your new HVAC equipment. It's been designed for long life and reliable service, and is backed by one of the strongest warranties in the industry. Your unit automatically qualifies for the warranty coverage listed below, providing you keep your proof of purchase (receipt) for the equipment and meet the warranty conditions.

LIMITED TEN (10) YEAR EXPRESS WARRANTY

MARS warrants all parts of the HEW/HNW residential geothermal heat pump including the compressor to be free from defects in workmanship and materials for normal use and maintenance for ten (10) years from the date of purchase by the original consumer for the original installation. This Express Limited Warranty applies only when the system is installed per MARS installation instructions and in accordance with all local, state and national codes for normal use.

LIMITED FIVE (5) YEAR LABOR ALLOWANCE

Labor is allowed for warranty service for a period of five (5) years from the date of purchase when the unit is properly registered and commissioned according to the start-up procedure specified in the Installation/Operation Manual, and when the Geothermal Start-Up Certification Form is completed and submitted to MARS.

EXCEPTIONS

The Limited Express Warranty does not cover normal maintenance—MARS recommends that regular inspection/maintenance be performed at least once a season and proof of maintenance be kept. Additionally, labor charges, transportation charges for replacement parts, replacement of refrigerant or filters, any other service calls/repairs are not covered by this Limited Warranty. It also does not cover any portion or component of the system that is not supplied by MARS, regardless of the cause of failure of such portion or component.

CONDITIONS FOR WARRANTY COVERAGE

- Unit must be operated according to MARS operating instructions included with the unit and cannot have been subjected to accident, alteration, improper repair, neglect or misuse, or an act of God (such as a flood)
- Installation was done by a trained, licensed or otherwise qualified HVAC dealer/contractor
- Performance cannot be impaired by use of any product not authorized by MARS, or by any adjustments or adaptations to components
- Serial numbers and/or rating plate have not been altered or removed
- Damage has not been a result of inadequate wiring or voltage conditions, use during brown-out conditions, or circuit interruptions
- Air flow around any section of the unit has not been restricted
- Unit remains in the original installation
- Unit was not purchased over the internet

DURATION OF WARRANTY & REGISTRATION

The warranty begins on the date of purchase by the original consumer. The consumer must retain a receipted bill of sale as proof of warranty period. Without this proof, the express warranty begins on the date of shipment from the factory.

REMEDY PROVIDED BY THE LIMITED EXPRESS WARRANTY

The sole remedy under the Limited Warranty is replacement of the defective part. If replacement parts are required within the period of this warranty, MARS replacement parts shall be used; any warranty on the replacement part(s) shall not affect the applicable original unit warranty. Ready access to the unit for service is the owner's responsibility. Labor to diagnose and replace the defective part is not covered by this Limited Express Warranty. If for any reason the replacement part/product is no longer available during the warranty period, MARS shall have the right to allow a credit in the amount of the current suggested retail price of the part/product instead of providing repair or replacement.

LIMITATION OF LIABILITY

1. There are no other express or implied warranties. MARS makes no warranty of merchantability. We do not warrant that the unit is suitable for any particular purpose or can be used in buildings or rooms of any particular size or condition except as specifically provided in this document. There are no other warranties, express or implied, which extend beyond the description in this document.
2. All warranties implied by law are limited in duration to the seven-year term of the parts warranty. Your exclusive remedy is limited to the replacement of defective parts. **We will not be liable for any consequential or incidental damages caused by any defect in this unit.**
3. This warranty gives you specific legal rights and you may also have other rights which vary from state to state. Some states do not allow limitation on how long an implied warranty lasts or do not allow the exclusion or limitation of incidental or consequential damages, so the above limitations or exclusions may not apply to you.
4. No warranties are made for units sold outside the continental United States and Canada. Your distributor or final seller may provide a warranty on units sold outside these areas.
5. MARS will not be liable for damages if our performance regarding warranty resolution is delayed by events beyond our control including accident, alteration, abuse, war, government restrictions, strikes, fire, flood, or other acts of God.

HOW TO OBTAIN WARRANTY SERVICE OR PARTS

If you have a warranty claim, notify your installer promptly. If the installer does not remedy your claim, write to MARS, 1900 Wellworth Ave., Jackson MI 49203. Enclose a report of inspection by your installer or service person. Include model number, serial number, and date of purchase.

Owner responsibilities are set forth in the instruction manual—read it carefully.

Please visit www.marsdelivers.com to register your new product



HEW-HNW_WARRANTY_11/2020

KEEP THIS INFORMATION AS A RECORD OF YOUR PURCHASE	
GEOTHERMAL HEAT PUMP	INSTALLATION
Model Number _____	Installer Name _____
Serial Number _____	Phone Number/Contact Information _____
Date of Purchase _____	Date Installation Completed _____
<input type="checkbox"/> Component of new HVAC system	<input type="checkbox"/> Replacement heat pump only
Remember to retain your bill of sale as proof of warranty period.	

Notes

Notes

Revision History

Date:	Item:	Action:
December 15, 2022	All	Transitioned from DXM to DXM2.5 unit controls
October 5, 2021	Pages 11-14	Updated Water Quality Requirements
August 21, 2018	Page 4	Added Warning
January 26, 2017	Page 14	Add caution
December 14, 2015	First Published	

Due to ongoing product improvements, specifications and dimensions are subject to change and correction without notice or incurring obligations. Determining the application and suitability for use of any product is the responsibility of the installer. Additionally, the installer is responsible for verifying dimensional data on the actual product prior to beginning any installation preparations.

Incentive and rebate programs have precise requirements as to product performance and certification. All products meet applicable regulations in effect on date of manufacture; however, certifications are not necessarily granted for the life of a product. Therefore, it is the responsibility of the applicant to determine whether a specific model qualifies for these incentive/rebate programs.



* 97B0123N02 *

97B0123N02

Installation, Operation, Maintenance