

# INSTALLATION INSTRUCTIONS

## HRG18 Units (R410A Refrigerant)

This manual must be left with the homeowner for future reference.



This is a safety alert symbol and should never be ignored. When you see this symbol on labels or in manuals, be alert to the potential for personal injury or death.

### **WARNING**

Installation and servicing of air conditioning equipment can be hazardous due to internal refrigerant pressure and live electrical components. Only trained and qualified service personnel should install or service this equipment. Installation and service performed by unqualified persons can result in property damage, personal injury, or death.

### **WARNING**

#### **ELECTRICAL SHOCK HAZARD!**



Risk of electrical shock. Disconnect all remote power supplies before installing or servicing any portion of the system. Failure to disconnect power supplies can result in property damage, personal injury, or death.

### **WARNING**

Sharp metal edges can cause injury. When installing the unit, use care to avoid sharp edges.

Manufactured By  
**Comfort-Aire / Century**  
1900 Wellworth Ave.  
Jackson, MI 49203

## Table of Contents

Application .....	1
General .....	2
Installation .....	2
Refrigerant Piping .....	4
Electrical - Circuit Sizing and Wire Routing .....	13
Thermostat Control and Low Voltage Control Wiring .....	13
Outdoor Unitary Control .....	17
Start-Up .....	18
Maintenance .....	20
Homeowner Information .....	21

### **IMPORTANT**

The Clean Air Act of 1990 bans the intentional venting of refrigerant (CFCs, HCFCs and HFCs) as of July 1, 1992. Approved methods of recovery, recycling or reclaiming must be followed. Fines and/or incarceration may be levied for noncompliance.

## Application

These units are designed for use in residential and light commercial type buildings. Units should be installed with approved indoor matches listed in the Air-Conditioning, Heating and Refrigeration Institute (AHRI) Directory of Certified Products. Refer to <http://www.ahridirectory.org>.



(P) 508133M01

## General

Read this entire instruction manual, as well as the instructions supplied in separate equipment, before starting the installation. Observe and follow all warnings, cautions, instructional labels, and tags. Failure to comply with these instructions could result in an unsafe condition and/or premature component failure.

These instructions are intended as a general guide only for use by qualified personnel and do not supersede any national or local codes in any way. The installation must comply with all provincial, state, and local codes as well as the National Electrical Code (U.S.) or Canadian Electrical Code (Canada). Compliance should be determined prior to installation.

This unit uses R-410A, which is an ozone-friendly HFC refrigerant. The unit must be installed with a matching indoor coil and line set. A filter drier approved for use with R-410A is installed in the unit.

**IMPORTANT:** *This product has been designed and manufactured to meet ENERGY STAR criteria for energy efficiency when matched with appropriate coil components. However, proper refrigerant charge and proper air flow are critical to achieve rated capacity and efficiency. Installation of this product should follow the manufacturer's refrigerant charging and air flow instructions. **Failure to confirm proper charge and airflow may reduce energy efficiency and shorten equipment life.***

## Inspection of Shipment

Upon receipt of equipment, carefully inspect it for possible shipping damage. If damage is found, it should be noted on the carrier's freight bill. Take special care to examine the unit inside the carton if the carton is damaged. Any concealed damage discovered should be reported to the last carrier immediately, preferably in writing, and should include a request for inspection by the carrier's agent.

If any damages are discovered and reported to the carrier **DO NOT INSTALL THE UNIT**, as claim may be denied.

Check the unit rating plate to confirm specifications are as ordered.

## Safety Precautions

Follow all safety codes. Wear safety glasses and work gloves. Use quenching cloth for brazing operations. Have fire extinguisher available. Read these instructions thoroughly and follow all warning or cautions attached to the unit.

1. Always wear proper personal protection equipment.
2. Always disconnect electrical power before removing panel or servicing equipment.
3. Keep hands and clothing away from moving parts.

4. Handle refrigerant with caution; refer to proper MSDS from refrigerant supplier.
5. Use care when lifting, avoid contact with sharp edges.

## Installation

**NOTE:** *In some cases, noise in the living area has been traced to gas pulsations from improper installation of equipment.*

- Locate unit away from windows, patios, decks, etc. where unit operation sounds may disturb customer.
  - Leave some slack between structure and unit to absorb vibration.
  - Place a sound-absorbing material, such as Isomode, under the unit if it will be installed in a location or position that will transmit sound or vibration to the living area or adjacent buildings.
  - Install the unit high enough above the ground or roof to allow adequate drainage of defrost water and prevent ice buildup.
  - In heavy snow areas, do not locate the unit where drifting snow will occur. The unit base should be elevated above the depth of average snows.
- NOTE:** *Elevation of the unit may be accomplished by constructing a frame using suitable materials. If a support frame is constructed, it must not block drain holes in unit base.*
- When installed in areas where low ambient temperatures exist, locate unit so winter prevailing winds do not blow directly into outdoor coil.
  - Locate unit away from overhanging roof lines which would allow water or ice to drop on, or in front of, coil or into unit.

## WARNING

To prevent personal injury, as well as damage to panels, unit or structure, observe the following:

While installing or servicing this unit, carefully stow all removed panels so that the panels will not cause injury to personnel, objects or nearby structures. Also, take care to store panels where they will not be subject to damage (e.g., being bent or scratched).

While handling or stowing the panels, consider any weather conditions (especially wind) that may cause panels to be blown around and damaged.

**⚠ IMPORTANT**

Exhaust vents from dryers, water heaters and furnaces should be directed away from the outdoor unit. Prolonged exposure to exhaust gases and the chemicals contained within them may cause condensation to form on the steel cabinet and other metal components of the outdoor unit. This will diminish unit performance and longevity.

When outdoor unit is connected to factory-approved indoor unit, outdoor unit contains system refrigerant charge for operation with matching indoor unit when connected by 15 ft. of field-supplied tubing. For proper unit operation, check refrigerant charge using charging information located on control box cover.

**Indoor Coil TXV Selection**

The outdoor section must be matched to a factory approved indoor section. It is mandatory that the installer ensure that the correct TXV is installed in the indoor section. Reference Refrigerant Piping - Typical Existing Fixed Orifice Removal Procedure. If necessary, remove the existing piston and replace it with the correct TXV. See Refrigerant Piping - Typical Existing Expansion Valve Removal Procedure for details of changing the piston or TXV. The HRG18 models are only rated with TXV on the indoor coil.

**Outdoor Section**

Zoning ordinances may govern the minimum distance the condensing unit can be installed from the property line.

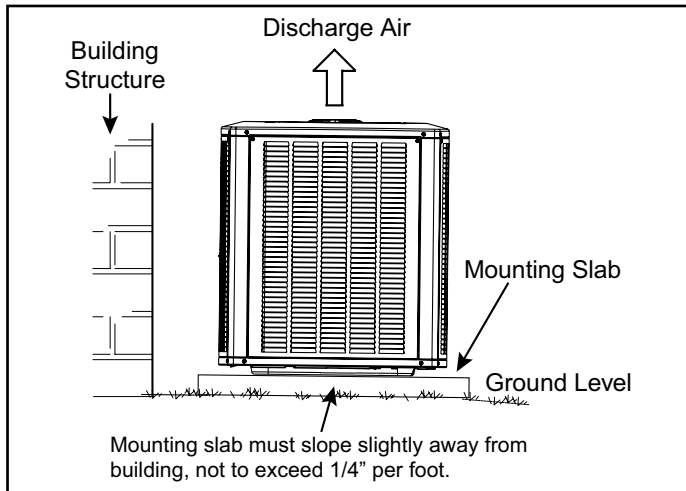

**Figure 1. Slab Mounting**

**Install on a Solid, Level Mounting Pad**

The outdoor section is to be installed on a solid foundation. This foundation should extend a minimum of 2" (inches) beyond the sides of the outdoor section. To reduce the possibility of noise transmission, the foundation slab should NOT be in contact with or be an integral part of the building foundation. See Figure 1.

If conditions or local codes require the unit be attached to pad or mounting frame, tie down bolts should be used and secured to unit base pan.

**Elevate Unit**

**⚠ CAUTION**

Accumulation of water and ice in base pan may cause equipment damage.

Elevate unit per local climate and code requirements to provide clearance above estimated snowfall level and ensure adequate drainage of unit. Use snow stand in areas where prolonged freezing temperatures are encountered.

If conditions or local codes require the unit be attached to pad or mounting frame, tie down bolts should be used and fastened through knockouts provided in unit base pan.

**Clearance Requirements**

When installing, allow sufficient space for airflow clearance, wiring, refrigerant piping, and service. For proper airflow, quiet operation and maximum efficiency. Position so water, snow, or ice from roof or eaves cannot fall directly on unit. Refer to Table 1 for installation clearances.

Location	Minimum Clearance
Service box	30"
Top of unit*	48"
Between units	24"
Against wall	6"

\* Maximum soffit overhang is 36".

**NOTE:** At least one side should be unobstructed by a wall or other barrier.

**Table 1. Clearances**

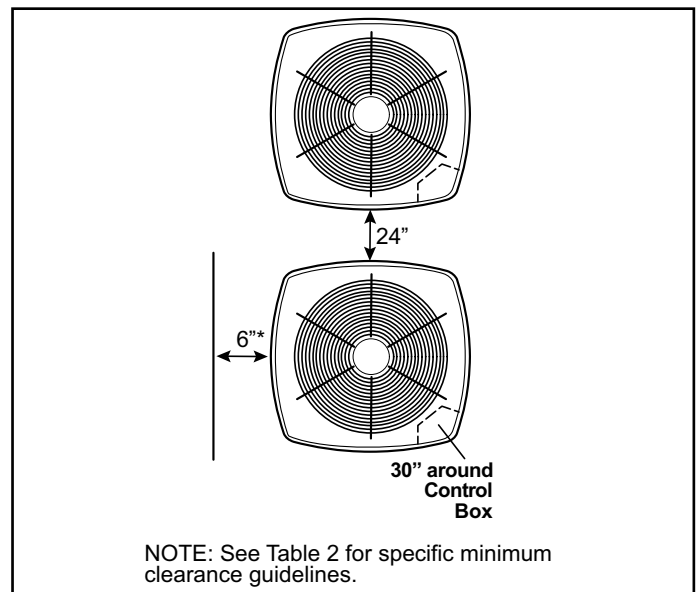

**NOTE:** See Table 2 for specific minimum clearance guidelines.

**Figure 2.**

**DO LOCATE THE UNIT:**

- With proper clearances on sides and top of unit
- On a solid, level foundation or pad (unit must be level to within ± 1/4 in./ft. per compressor manufacturer specifications)
- To minimize refrigerant line lengths

**DO NOT LOCATE THE UNIT:**

- On brick, concrete blocks or unstable surfaces
- Near clothes dryer exhaust vents
- Near sleeping area or near windows
- Under eaves where water, snow or ice can fall directly on the unit
- With clearance less than 2 ft. from a second unit
- With clearance less than 4 ft. on top of unit

**Operating Ambient**

The minimum outdoor operating ambient in cooling mode is 55°F, and the maximum outdoor operating ambient in cooling mode is 125°F. The maximum outdoor operating ambient in heating mode is 66°F.

**Rooftop Installations**

Install unit at a minimum of 6” above surface of the roof to avoid ice buildup around the unit. Locate the unit above a load bearing wall or area of the roof that can adequately support the unit. Consult local codes for rooftop applications.

If unit cannot be mounted away from prevailing winds, a wind barrier should be constructed. Due to variation in installation applications, size and locate barrier according to the best judgment of the installer.

**Refrigerant Piping**

- Use only refrigerant grade copper tubes.
- Split systems may be installed with up to 50 feet of line set (no more than 20 feet vertical) without special consideration (see long line set guidelines).
- Ensure that vapor and liquid tube diameters are appropriate to capacity of unit.
- Run refrigerant tubes as directly as possible by avoiding unnecessary turns and bends.
- When passing refrigerant tubes through the wall, seal opening with RTV or other silicon-based caulk.
- Avoid direct tubing contact with water pipes, duct work, floor joists, wall studs, floors, walls, and any structure.
- Do not suspend refrigerant tubing from joists and studs with a rigid wire or strap that comes in direct contact with tubing.

- Ensure that tubing insulation is pliable and completely surrounds vapor tube.

It is important that no tubing be cut or seals broken until you are ready to actually make connections to the evaporator and to the condenser section. DO NOT remove rubber plugs or copper caps from the tube ends until ready to make connections at evaporator and condenser. Under no circumstances leave the lines open to the atmosphere for any period of time, if so unit requires additional evacuation to remove moisture.

Operating Mode	18 SEER	
	Liquid Line	Suction Line
2 Ton	3/8	3/4
3 Ton	3/8	3/4
4 Ton	3/8	7/8
5 Ton	3/8	1 1/8

**Table 2.**

Be extra careful with sharp bends. Tubing can “kink” very easily, and if this occurs, the entire tube length will have to be replaced. Extra care at this time will eliminate future service problems.

It is recommended that vertical suction risers not be up-sized. Proper oil return to the compressor should be maintained with suction gas velocity.

**Filter Drier**

The filter drier is very important for proper system operation and reliability. If the drier is shipped loose, it must be installed by the installer in the field. Unit warranty will be void, if the drier is not installed.

**Installation of Line Sets**

**DO NOT** fasten liquid or suction lines in direct contact with the floor or ceiling joist. Use an insulated or suspension type of hanger. Keep both lines separate, and always insulate the suction line. Liquid line runs (30 feet or more) in an attic will require insulation. Route refrigeration line sets to minimize length.

**DO NOT** let refrigerant lines come in direct contact with foundation. When running refrigerant lines through the foundation or wall, openings should allow for a sound and vibration absorbing material to be placed or installed between tubing and foundation. Any gap between foundation or wall and refrigerant lines should be filled with a vibration damping material.

**⚠ CAUTION**

If ANY refrigerant tubing is required to be buried by state or local codes, provide a 6 inch vertical rise at service valve.

**⚠ WARNING**

Polyvinyl ether (PVE) oils used with HFC-410A refrigerant absorb moisture very quickly. It is very important that the refrigerant system be kept closed as much as possible. DO NOT remove line set caps or service valve stub caps until you are ready to make connections.

**⚠ CAUTION**

Do **NOT** attempt to flush and re-use existing line sets or indoor coil when the system contains contaminants (i.e., compressor burn out).

**NOTE**

“Clean refrigerant” is any refrigerant in a system that has not had compressor burnout. If the system has experienced burnout, it is recommended that the existing line set and indoor coil be replaced.

**NOTE**

In lieu of R-410A, an industry-standard flushing agent may also be used.

**Suction Traps**

For systems with the outdoor unit 5 - 60 feet above the indoor unit, one trap must be installed at the bottom of the suction riser.

**NOTE:** *Special consideration must be taken for line sets over 50 feet. See Refrigerant Piping Guidelines.*

Tonnage *	Valve Size Connections		Recommended Line Sets
	Liquid Line	Suction Line	Line Set Length
-024	3/8" (10mm)	3/4" (19mm)	30' (9.1m)
-036			40' (12.2m)
-048		7/8" (22mm)	50' (15.2m)
-060		1-1/8" (29mm) **	Field-fabricated

\* Applicable to all minor revision numbers unless otherwise specified.  
 \*\* Some applications may require a field-provided 1-1/8" to 7/8" adapter.

**Table 3. Standard Refrigerant Line Set – Up to 50 Linear Feet in Length**

### Typical Existing Fixed Orifice Removal Procedure

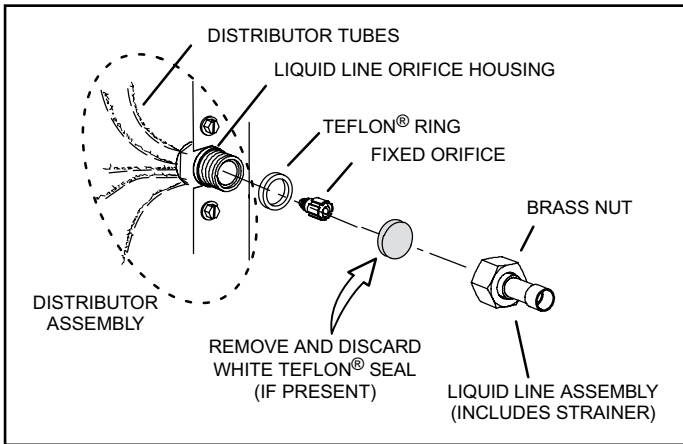

**Figure 3. Remove Fixed Orifice (Uncased Coil Shown)**

1. On fully cased coils, remove the coil access and plumbing panels.
2. Remove any shipping clamps from the liquid line and distributor assembly.
3. Using two wrenches (one to hold the orifice housing and one to remove the brass nut), disconnect liquid line from liquid line orifice housing. Take care not to twist or damage distributor tubes during this process.
4. Remove and discard fixed orifice, valve stem assembly (if present) and Teflon® washer, as shown in Figure 3.
5. Use a field-provided fitting to temporarily reconnect the liquid line to the indoor unit's liquid line orifice housing.

### Typical Existing Expansion Valve Removal Procedure

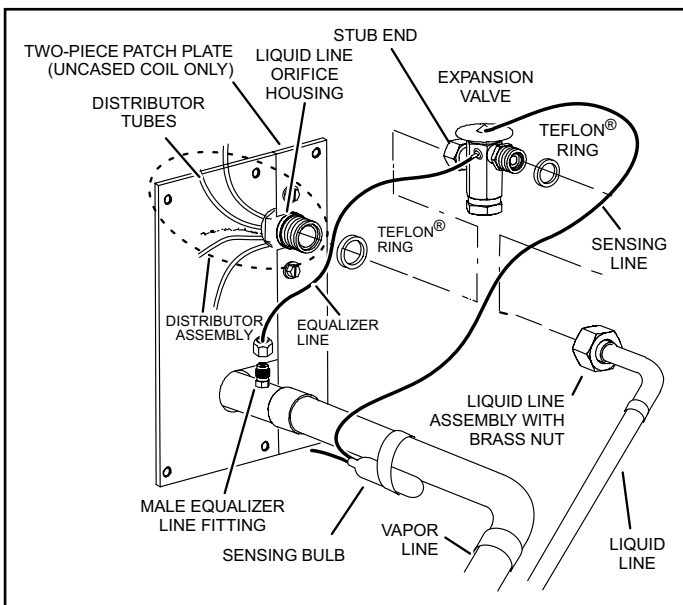

**Figure 4. Remove Expansion Valve (Uncased Coil Shown)**

1. On fully cased coils, remove the coil access and plumbing panels.
2. Remove any shipping clamps from the liquid line and distributor assembly.
3. Disconnect the equalizer line from the fitting on the vapor line.
4. Remove the vapor line sensing bulb.
5. Disconnect the liquid line from the expansion valve at the liquid line assembly.
6. Disconnect the expansion valve from the liquid line orifice housing. Take care not to twist or damage distributor tubes during this process.
7. Remove and discard expansion valve and the two Teflon® rings.
8. Use a field-provided fitting to temporarily reconnect the liquid line to the indoor unit's liquid line orifice housing.

### Connect Gauges and Equipment for Flushing Procedure

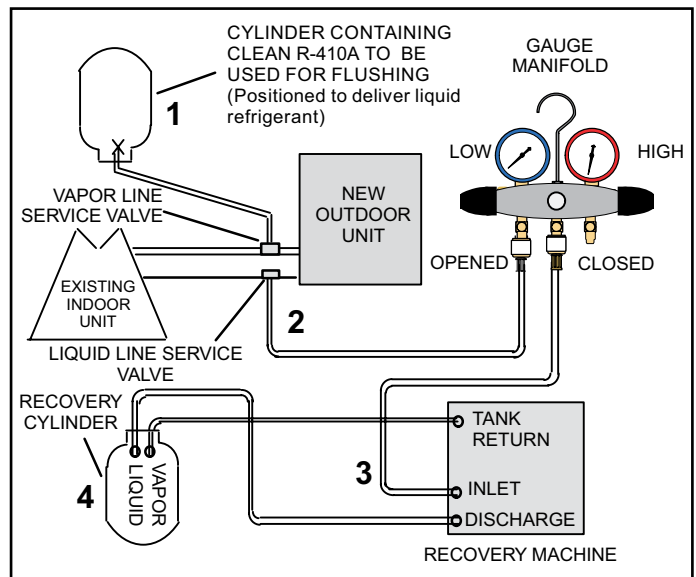

**Figure 5. Connecting Gauges**

1. Cylinder with clean R-410A (positioned to deliver liquid refrigerant) to the vapor service valve.
2. Refrigerant gauge set (low side) to the liquid line valve.
3. Refrigerant gauge set center port to inlet on the recovery machine with an empty recovery tank connected to the gauge set.
4. Connect recovery tank to recovery machine per machine instructions.

## Flushing Line Sets

If the unit will be installed in an existing system that uses an indoor unit or line sets charged with R-22 refrigerant, installer must perform the following flushing procedure.

**NOTE:** Existing system components (including line set and indoor coil) must be an AHRI match with the unit in order to fulfill unit warranty requirements.

### WARNING



Fire, Explosion and Personal Safety hazard. Failure to follow this warning could result in damage, personal injury or death.



Never use oxygen to pressurize or purge refrigeration lines. Oxygen, when exposed to a spark or open flame, can cause fire and/or an explosion, that could result in property damage, personal injury or death.

### WARNING



When using a high pressure gas such as nitrogen to pressurize a refrigeration or air conditioning system, use a regulator that can control the pressure down to 1 or 2 psig (6.9 to 13.8 kPa).

### WARNING

Refrigerant must be reclaimed in accordance with national and local codes.

1. Set the recovery machine for liquid recovery and start the recovery machine. Open the gauge set valves to allow the recovery machine to pull a vacuum on the existing system line set and indoor unit coil.
2. Position the cylinder of clean R-410A for delivery of liquid refrigerant and open its valve to allow liquid refrigerant to flow into the system through the vapor line valve. Allow the refrigerant to pass from the cylinder and through the line set and the indoor unit coil before it enters the recovery machine.
3. After all of the liquid refrigerant has been recovered, switch the recovery machine to vapor recovery so that all of the R-410A vapor is recovered. Allow the recovery machine to pull the system down to 0.
4. Close the valve on the inverted R-410A drum and the gauge set valves. Pump the remaining refrigerant out of the recovery machine and turn the machine off.

## Refrigerant Piping - Install Indoor Expansion Valve

This outdoor unit is designed for use in systems that include a heat pump expansion valve metering device at the indoor coil. See the Product Specifications for approved expansion valve kit match-ups and application information. The expansion valve unit can be installed internal or external to the indoor coil. In applications where an uncased coil is being installed in a field-provided plenum, install the expansion valve in a manner that will provide access for future field service of the expansion valve. Refer to below illustration for reference during installation of expansion valve unit.

### INDOOR EXPANSION VALVE INSTALLATION

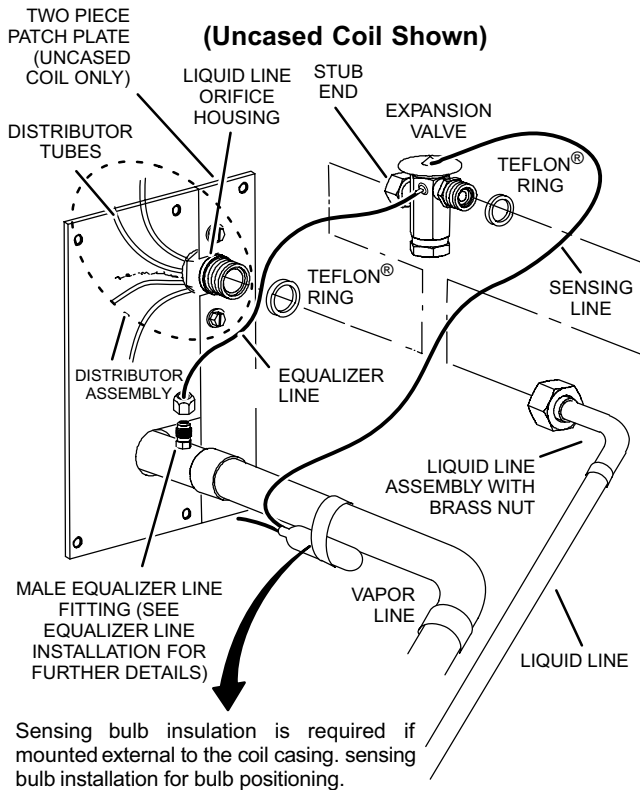

- 3 - Install one of the provided Teflon® rings around the stubbed end of the check expansion valve and lightly lubricate the connector threads and expose surface of the Teflon® ring with refrigerant oil.
- 4 - Attach the stubbed end of the check expansion valve to the liquid line orifice housing. Finger tighten and use an appropriately sized wrench to turn an additional 1/2 turn clockwise as illustrated in the figure above, or tighten to 20 ft-lb.
- 5 - Place the remaining Teflon® washer around the other end of the check expansion valve. Lightly lubricate connector threads and expose surface of the Teflon® ring with refrigerant oil.
- 6 - Attach the liquid line assembly to the check expansion valve. Finger tighten and use an appropriately sized wrench to turn an additional 1/2 turn clockwise as illustrated in the figure above or tighten to 20 ft-lb.

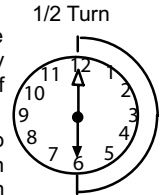

### SENSING BULB INSTALLATION

- 1 - Attach the vapor line sensing bulb in the proper orientation as illustrated to the right using the clamp and screws provided.

**NOTE** - Though it is preferred to have the sensing bulb installed on a horizontal run of the vapor line, installation on a vertical run of piping is acceptable if necessary.

**NOTE** - Confirm proper thermal contact between vapor line and check/expansion bulb before insulating the sensing bulb once installed.

- 2 - Connect the equalizer line from the check expansion valve to the equalizer vapor port on the vapor line. Finger tighten the flare nut plus 1/8 turn (7 ft-lbs) as illustrated below.

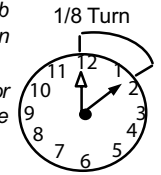

### EQUALIZER LINE INSTALLATION

- 1 - Remove and discard either the flare seal cap or flare nut with copper flare seal bonnet from the equalizer line port on the vapor line as illustrated in the figure below.
- 2 - Remove the field-provided fitting that temporarily reconnected the liquid line to the indoor unit's distributor assembly.

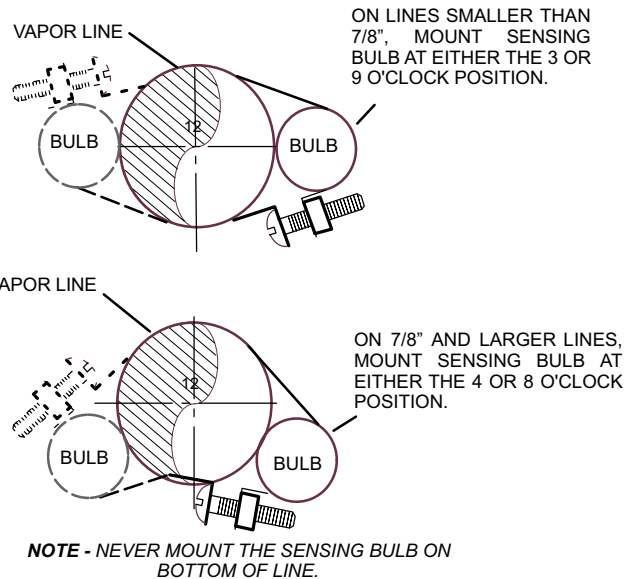
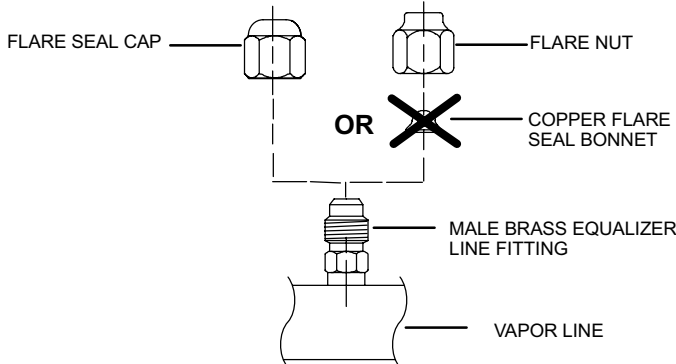

**Refrigerant Piping - Brazing Procedures**

**1 CUT AND DEBUR**

Cut ends of the refrigerant lines square (free from nicks or dents) and debur the ends. The pipe must remain round. Do not crimp end of the line.

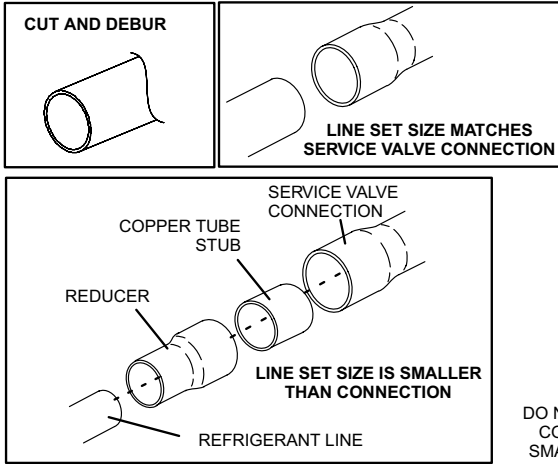

**2 CAP AND CORE REMOVAL**

Remove service cap and core from both the vapor and liquid line service ports.

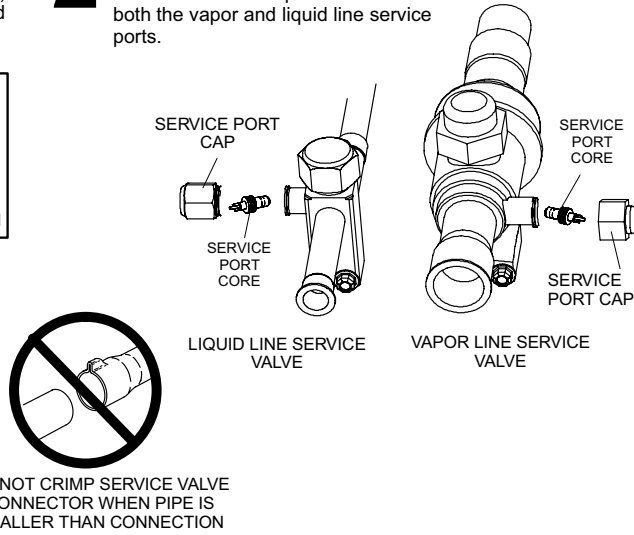

**3 ATTACH THE MANIFOLD GAUGE SET FOR BRAZING LIQUID AND VAPOR LINE SERVICE VALVES**

Flow regulated nitrogen (at 1 to 2 psig) through the low-side refrigeration gauge set into the liquid line service port valve, and out of the vapor line service port valve.

- A - Connect gauge set low pressure side to liquid line service valve (service port).
- B - Connect gauge set center port to bottle of nitrogen with regulator.
- C - Remove core from valve in vapor line service port to allow nitrogen to escape.

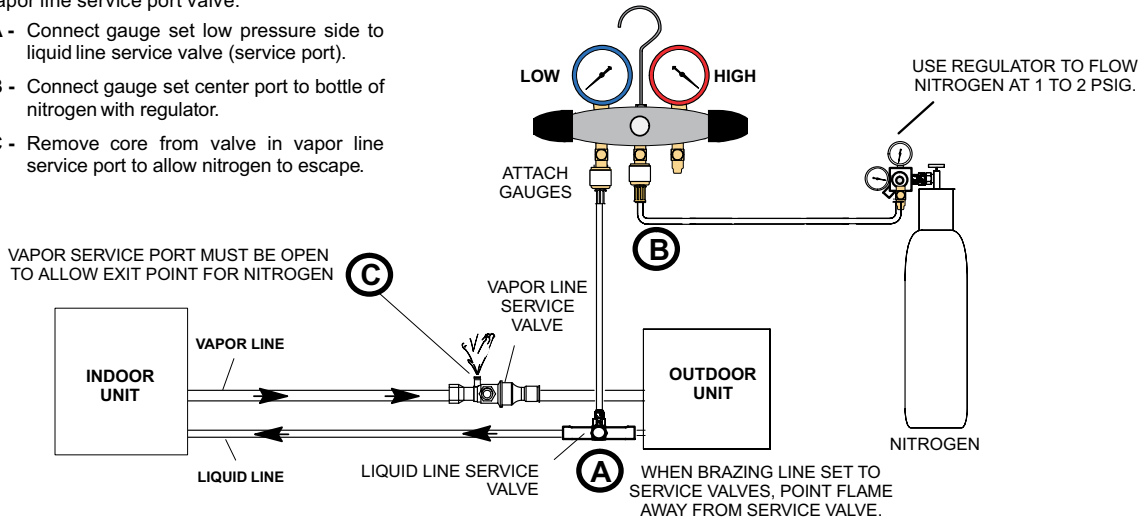

**NOTE**

Use a manifold gauge set designed for use on R-410A refrigerant systems.

**⚠ WARNING**



Before brazing, ensure the system is fully recovered of all refrigerant. Application of a brazing torch to a pressurized system may result in ignition of the refrigerant and oil mixture. Check the high and low pressures before applying heat.

**⚠ WARNING**

Brazing alloys and flux contain materials which are hazardous to your health.

Avoid breathing vapors or fumes from brazing operations. Perform operations only in well-ventilated areas.

Wear gloves and protective goggles or face shield to protect against burns.

Wash hands with soap and water after handling brazing alloys and flux.

## 4 WRAP SERVICE VALVES

To help protect service valve seals during brazing, wrap water-saturated cloths around service valve bodies and copper tube stubs. Use additional water-saturated cloths underneath the valve body to protect the base paint.

## 5 FLOW NITROGEN

Flow regulated nitrogen (at 1 to 2 psig) through the refrigeration gauge set into the valve stem port connection on the liquid service valve and out of the vapor valve stem port. See steps 3A, 3B and 3C on manifold gauge set connections.

## 6 BRAZE LINE SET

Wrap both service valves with water-saturated cloths as illustrated here and as mentioned in step 4, before brazing to line set. Cloths must remain water-saturated throughout the brazing and cool-down process.

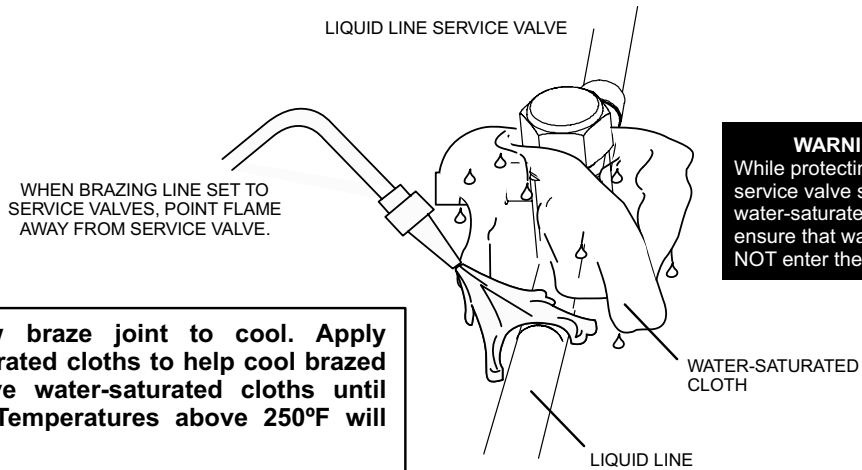

**IMPORTANT — Allow braze joint to cool. Apply additional water-saturated cloths to help cool brazed joint. Do not remove water-saturated cloths until piping has cooled. Temperatures above 250°F will damage valve seals.**

**WARNING**

**FIRE, PERSONAL INJURY, OR PROPERTY DAMAGE** may result if you do not wrap a water-saturated cloth around both liquid and suction line service valve bodies and copper tube stub while brazing the line set! The braze, when complete, must be quenched with water to absorb any residual heat.

Do not open service valves until refrigerant lines and indoor coil have been leak-tested and evacuated. Refer to Leak Test and Evacuation section of this manual.

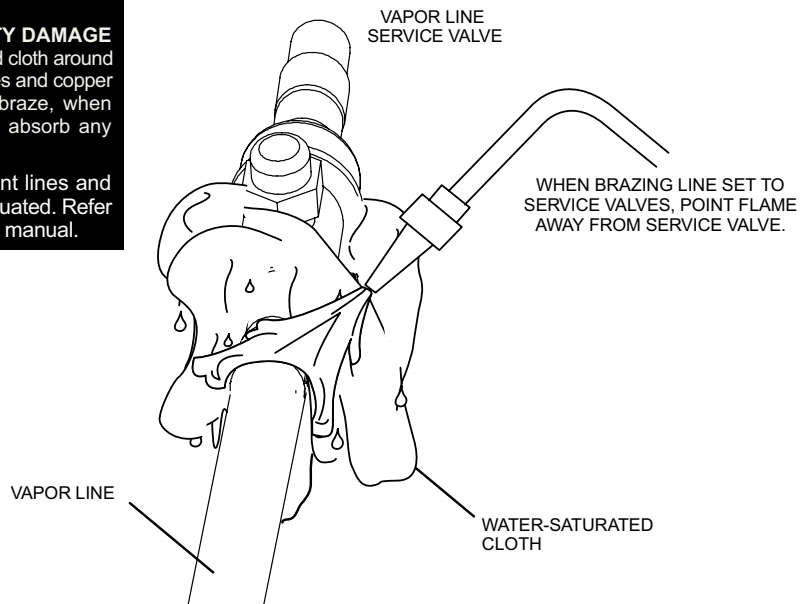

## 7 PREPARATION FOR NEXT STEP

After all connections have been brazed, disconnect manifold gauge set from service ports. Apply additional water-saturated cloths to both services valves to cool piping. Once piping is cool, remove all water-saturated cloths.

**Leak Test and Evacuation**

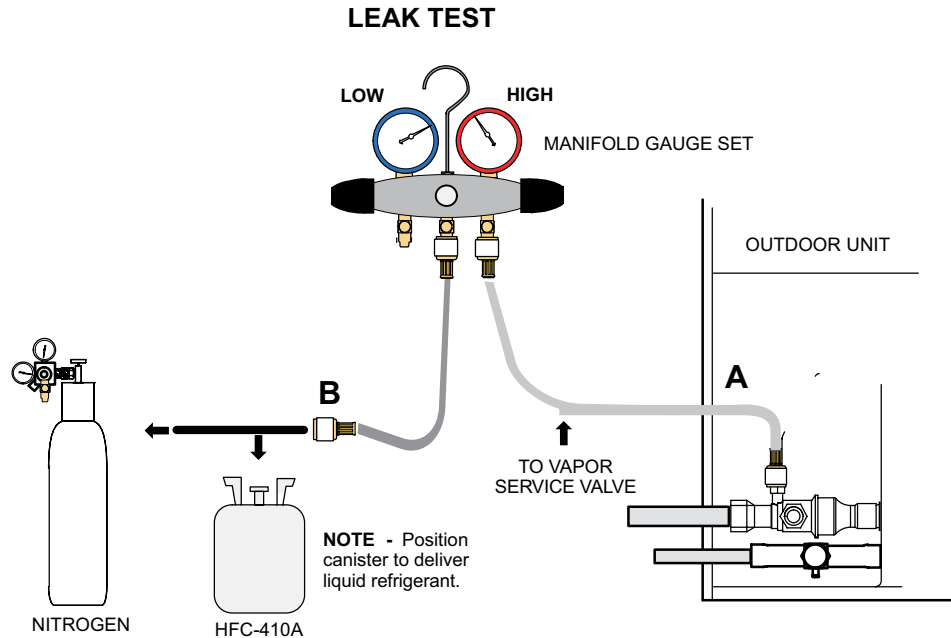

**1** CONNECT GAUGE SET

- A** - Connect the high pressure hose of an HFC-410A manifold gauge set to the vapor valve service port.  
**NOTE** - Normally, the high pressure hose is connected to the liquid line port. However, connecting it to the vapor port better protects the manifold gauge set from high pressure damage.
- B** - With both manifold valves closed, connect the cylinder of HFC-410A refrigerant to the center port of the manifold gauge set.  
**NOTE** - Later in the procedure, the HFC-410A container will be replaced by the nitrogen container.

**2** TEST FOR LEAKS

After the line set has been connected to the indoor and outdoor units, check the line set connections and indoor unit for leaks. Use the following procedure to test for leaks:

- A** - With both manifold valves closed, connect the cylinder of HFC-410A refrigerant to the center port of the manifold gauge set. Open the valve on the HFC-410A cylinder (vapor only).
- B** - Open the high pressure side of the manifold to allow HFC-410A into the line set and indoor unit. Weigh in a trace amount of HFC-410A. [A trace amount is a maximum of two ounces (57 g) refrigerant or three pounds (31 kPa) pressure.] Close the valve on the HFC-410A cylinder and the valve on the high pressure side of the manifold gauge set. Disconnect the HFC-410A cylinder.
- C** - Connect a cylinder of nitrogen with a pressure regulating valve to the center port of the manifold gauge set.
- D** - Adjust nitrogen pressure to 150 psig (1034 kPa). Open the valve on the high side of the manifold gauge set in order to pressurize the line set and the indoor unit.
- E** - After a few minutes, open one of the service valve ports and verify that the refrigerant added to the system earlier is measurable with a leak detector.
- F** - After leak testing, disconnect gauges from service ports.  
**NOTE** - Service valve cores remain removed for the following evacuation procedure.

### 3 CONNECT GAUGE SET

**NOTE** - Remove cores from service valves (if not already done).

- A - Connect low side of manifold gauge set with 1/4 SAE in-line tee to vapor line service valve
- B - Connect high side of manifold gauge set to liquid line service valve
- C - Connect available micron gauge connector on the 1/4 SAE in-line tee.
- D - Connect the vacuum pump (with vacuum gauge) to the center port of the manifold gauge set. The center port line will be used later for both the HFC-410A and nitrogen containers.

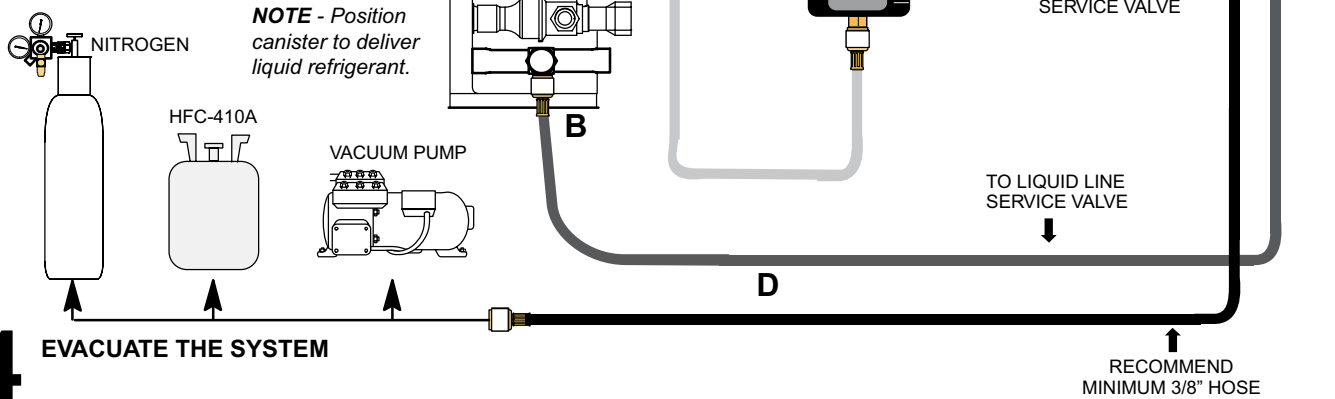

**NOTE** - Position canister to deliver liquid refrigerant.

### 4 EVACUATE THE SYSTEM

- A - Open both manifold valves and start the vacuum pump.
- B - Evacuate the line set and indoor unit until a slight vacuum is indicated on the micron gauge (approximately 23,000 microns or 29.01 inches of mercury).
  - NOTE** - During the early stages of evacuation, it is desirable to close the manifold gauge valve at least once. A rapid rise in pressure indicates a relatively large leak. If this occurs, **repeat the leak testing procedure**.
  - NOTE** - The term **absolute pressure** means the total actual pressure above absolute zero within a given volume or system. Absolute pressure in a vacuum is equal to atmospheric pressure minus vacuum pressure.
- C - When the absolute pressure reaches 23,000 microns (29.01 inches of mercury), perform the following:
  - Close manifold gauge valves.
  - Close valve on vacuum pump.
  - Turn off vacuum pump.
  - Disconnect manifold gauge center port hose from vacuum pump.
  - Attach manifold center port hose to a nitrogen cylinder with pressure regulator set to 150 psig (1034 kPa) and purge the hose.
  - Open manifold gauge valves to break the vacuum in the line set and indoor unit.
  - Close manifold gauge valves.
- D - Shut off the nitrogen cylinder and remove the manifold gauge hose from the cylinder. Open the manifold gauge valves to release the nitrogen from the line set and indoor unit.
- E - Reconnect the manifold gauge to the vacuum pump, turn the pump on, and continue to evacuate the line set and indoor unit until the absolute pressure does not rise above 500 microns (29.9 inches of mercury) within a 20-minute period after shutting off the vacuum pump and closing the manifold gauge valves.
- F - When the absolute pressure requirement above has been met, disconnect the manifold hose from the vacuum pump and connect it to a cylinder of HFC-410A positioned to deliver liquid refrigerant. Open the manifold gauge valve 1 to 2 psig in order to release the vacuum in the line set and indoor unit.
- G - Perform the following:
  - Close manifold gauge valves.
  - Shut off HFC-410A cylinder.
  - Reinstall service valve cores by removing manifold hose from service valve. Quickly install cores with core tool while maintaining a positive system pressure.
  - Replace stem caps and finger tighten them, then tighten an additional one-sixth (1/6) of a turn as illustrated.
- H - Open suction service valve first before liquid valve to release the unit charge into the system. Replace valve caps and tighten (8 ft. lb.). Caps are the primary seal.

**WARNING !**

**Possible equipment damage.**

**Avoid deep vacuum operation. Do not use compressors to evacuate a system. Extremely low vacuum can cause internal arcing and compressor failure. Damage caused by deep vacuum operation will void warranty.**

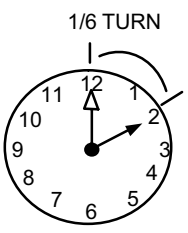

## Electrical - Circuit Sizing and Wire Routing

In the U.S.A., wiring must conform with current local codes and the current National Electric Code (NEC). In Canada, wiring must conform with current local codes and the current Canadian Electrical Code (CEC).

Refer to the furnace or air handler installation instructions for additional wiring application diagrams and refer to unit nameplate for minimum circuit ampacity and maximum overcurrent protection size.

### 24VAC Transformer

Use the transformer provided with the furnace or air handler for low-voltage control power (24VAC - 40 VA minimum).

## Thermostat Control and Low Voltage Control Wiring

### Conventional 24VAC Non-Communicating Thermostat Control

The HRG18 variable capacity unit may be installed using a conventional 24VAC non-communicating two-stage cooling or single-stage cooling thermostat.

The HRG18 unit will provide full variable capacity operation when installed with a conventional 24VAC non-communicating two stage heat pump or single-stage heat pump thermostat. The HRG18 outdoor control has advanced control algorithms, which provide true variable speed capacity operation by modulating the compressor speed to achieve the target suction pressure set point in cooling mode, and liquid pressure set point in heating mode.

When utilizing a two-stage conventional 24VAC non-communicating thermostat, six wires are required to control the outdoor unit (R, C, W1, O, Y1 and Y2). Refer to the HRG18 field wiring diagram for a conventional 24VAC non-communicating 2-stage thermostat.

When utilizing a single conventional 24VAC non-communicating thermostat, five wires are required to control the outdoor unit (R, C, W1, O, and Y1) and Y1 is jumpered to Y2 in the outdoor unit. Note that the published performance data is based upon the use of a two-stage thermostat. Refer to the HRG18 field wiring diagram for a conventional 24VAC non-communicating single-stage thermostat.

## HRG18 Low Voltage Control Wiring Connections

The HRG18 variable capacity units are provided with (2) RAST 6-Pin connections for connecting the field low voltage control wiring to the HRG18 harnesses in the low voltage control make-up box. One RAST 6-pin connector is labeled with terminals TST, DF, R, I+, I- and C. The second RAST 6-pin connector is labeled with terminals DS, O, Y1, Y2, L and W.

### WARNING

#### Electrical Shock Hazard!

Can cause injury or death. Unit must be properly grounded in accordance with national and local codes.



Line voltage is present at all components when unit is not in operation on units with single-pole contactors. Disconnect all remote electric power supplies before opening access panel. Unit may have multiple power supplies.

### WARNING

Fire Hazard. Use of aluminum wire with this product may result in a fire, causing property damage, severe injury or death. Use copper wire only with this product.

### WARNING

Failure to use properly sized wiring and circuit breaker may result in property damage. Size wiring and circuit breaker(s) per Technical Specifications and unit rating plate.

### WARNING

#### ELECTROSTATIC DISCHARGE (ESD)

##### Precautions and Procedures

Electrostatic discharge can affect electronic components. Take care during unit installation and service to protect the unit's electronic controls. Precautions will help to avoid control exposure to electrostatic discharge by putting the unit, the control and the technician at the same electrostatic potential. Touch hand and all tools on an unpainted unit surface before performing any service procedure to neutralize electrostatic charge.

Thermostat Type	Indoor Unit Type	Qty. of Wires to HRG18	HRG18 Terminal Strip Connections	Unit Operation	Field Wiring Diagram
Conventional 24VAC 2-Stage Cooling Thermostat (non-communicating)	Any Furnace or Air Handler (non-communicating)	6	R, C, W1, O, Y1, Y2	Full Variable Capacity Operation Controlled by HRG18 Unitary Control Using Suction Pressure	Figure 10
Conventional 24VAC Single-Stage Cooling Thermostat (non-communicating)	Any Furnace or Air Handler (non-communicating)	5	R, C, W1, O, Y1 (Jumper Y1 to Y2)	Full Variable Capacity Operation Controlled by HRG18 Unitary Control Using Suction Pressure	Figure 9

**Table 4. HRG18 Thermostat Control Options**

**Size Circuit and Install Service Disconnect Switch**

Refer to the unit nameplate for minimum circuit ampacity, and maximum fuse or circuit breaker (HACR per NEC). Install power wiring and properly sized disconnect switch.

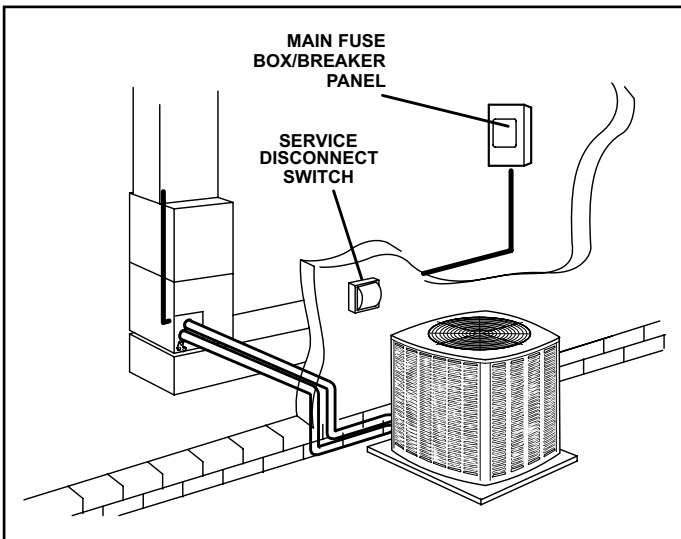
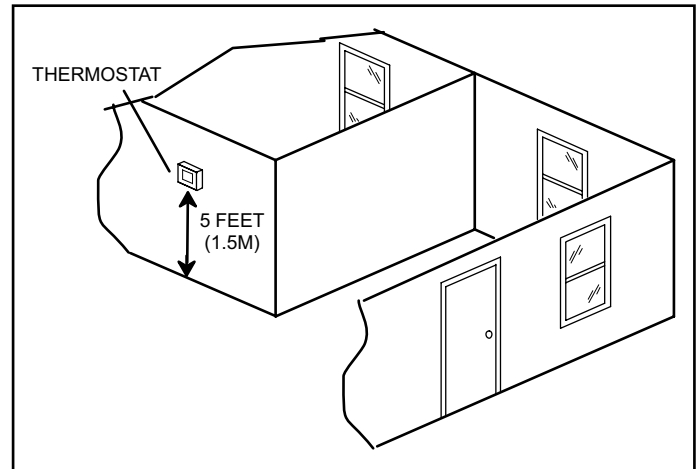

**Figure 6.**

**NOTE:** Units are approved for use only with copper conductors. Ground unit at disconnect switch or connect to an earth ground.

**Install Thermostat**

Install room thermostat (ordered separately) on an inside wall approximately in the center of the conditioned area and 5 feet (1.5m) from the floor. It should not be installed on an outside wall or where it can be affected by sunlight or drafts.



**Figure 7.**

**NOTE:** 24VAC, Class II circuit connections are made in the control panel.

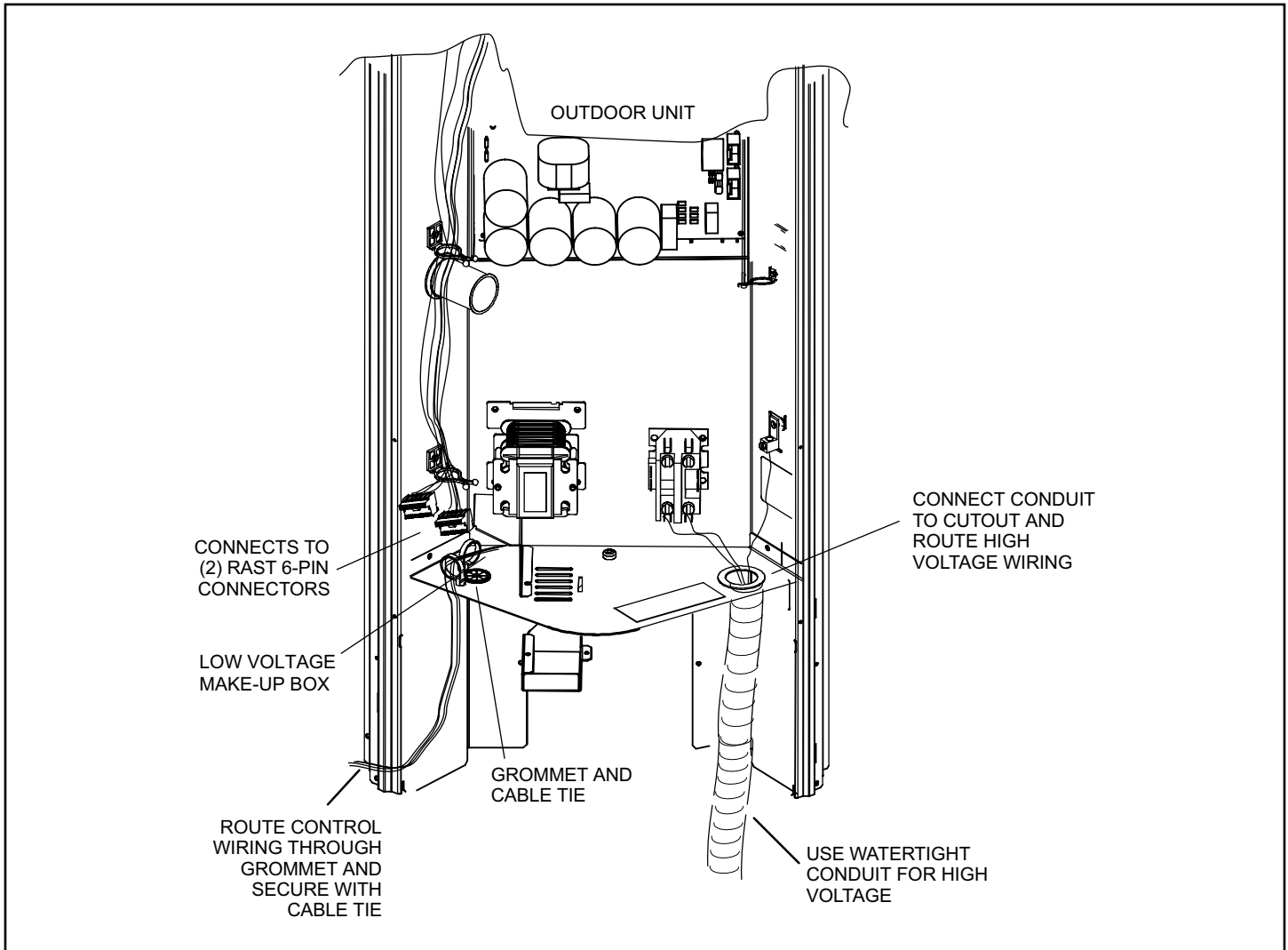

Figure 8.

**Route Control Wires**

Wire Run Length	AWG#	Insulation Type
Less than 100' (30m)	18	Temperature Rating 35°C Minimum
More than 100' (30m)	16	

**Table 5. Conventional 24VAC Non-Communicating Thermostat Wiring**

**Route High Voltage and Ground Wires**

Any excess high voltage field wiring should be trimmed and secured away from any low voltage field wiring. To facilitate a conduit, a cutout is located on the bottom of the control box. Connect conduit to the control box using a proper conduit fitting.

Connect the 208/230 high voltage power supply from the disconnect to the HRG18 contactor as shown. Connect the ground wire from the power supply to the unit ground lug connection.

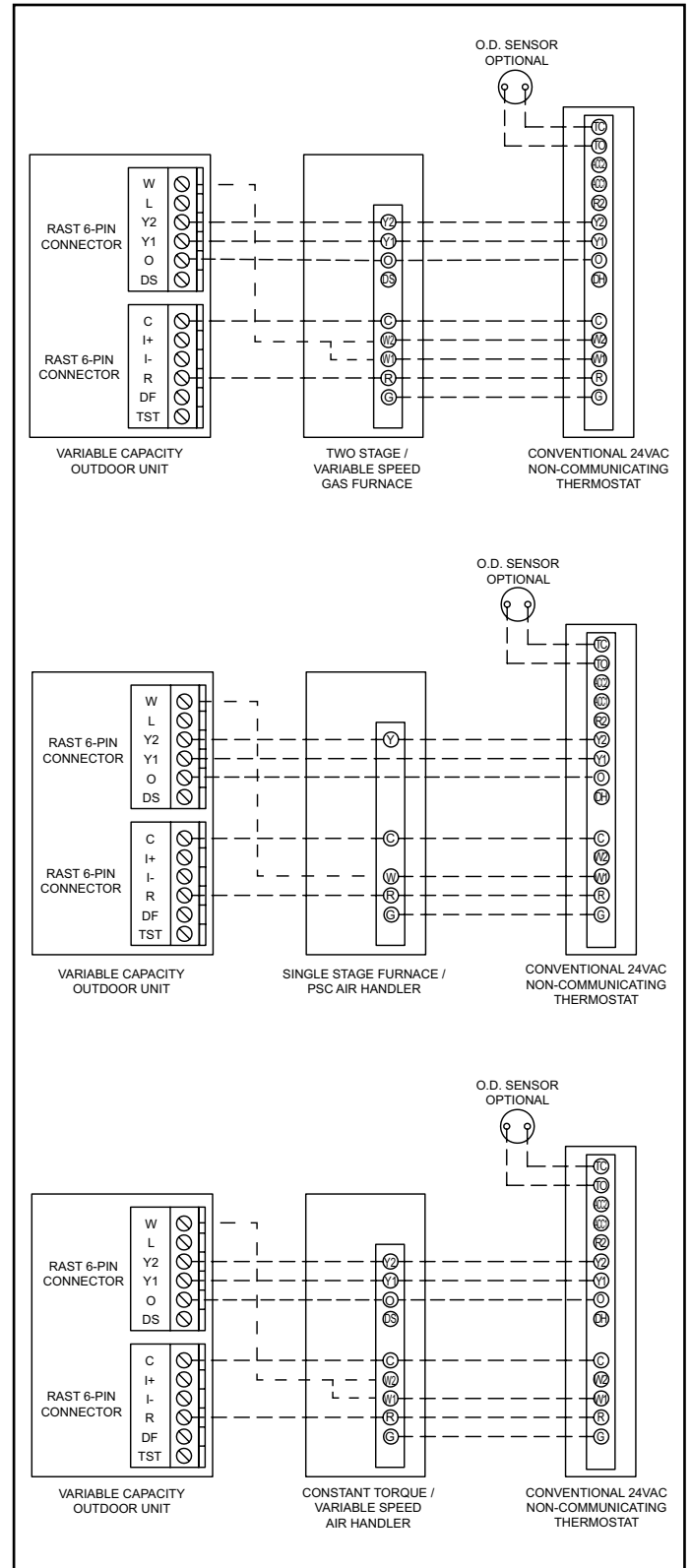
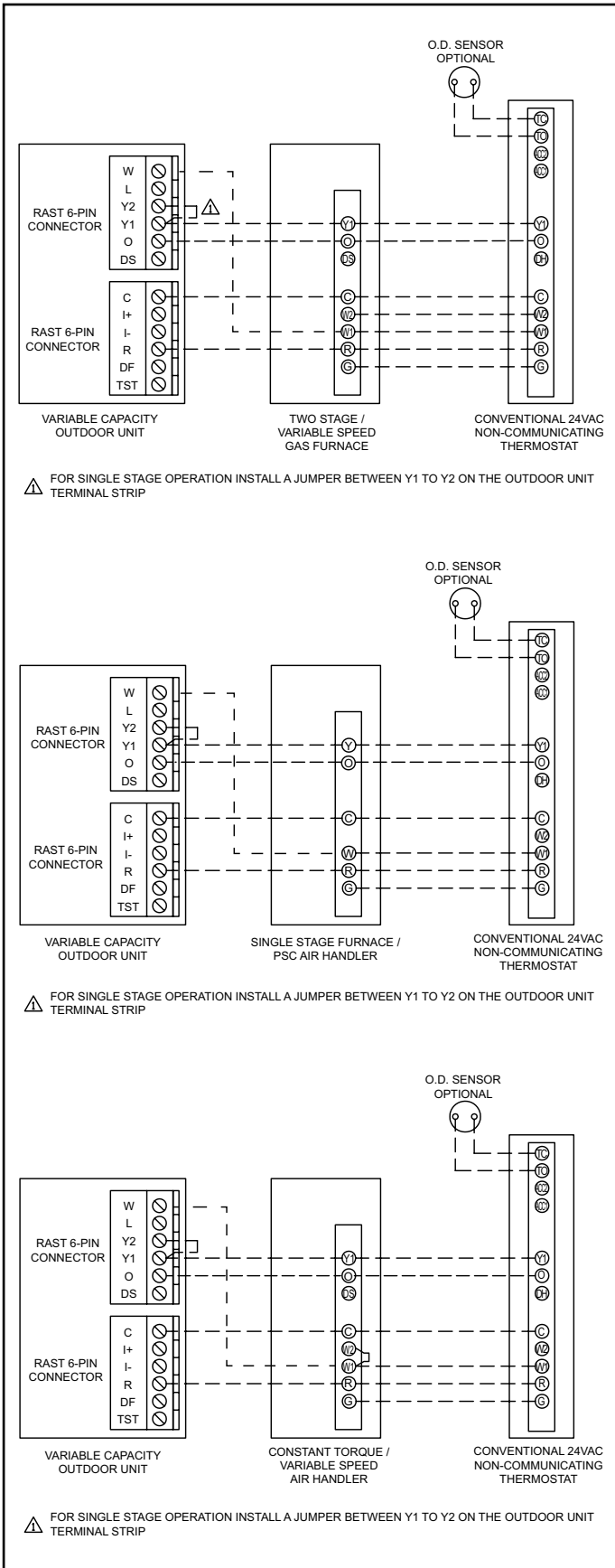

## Outdoor Unitary Control

### Jumpers and Terminals

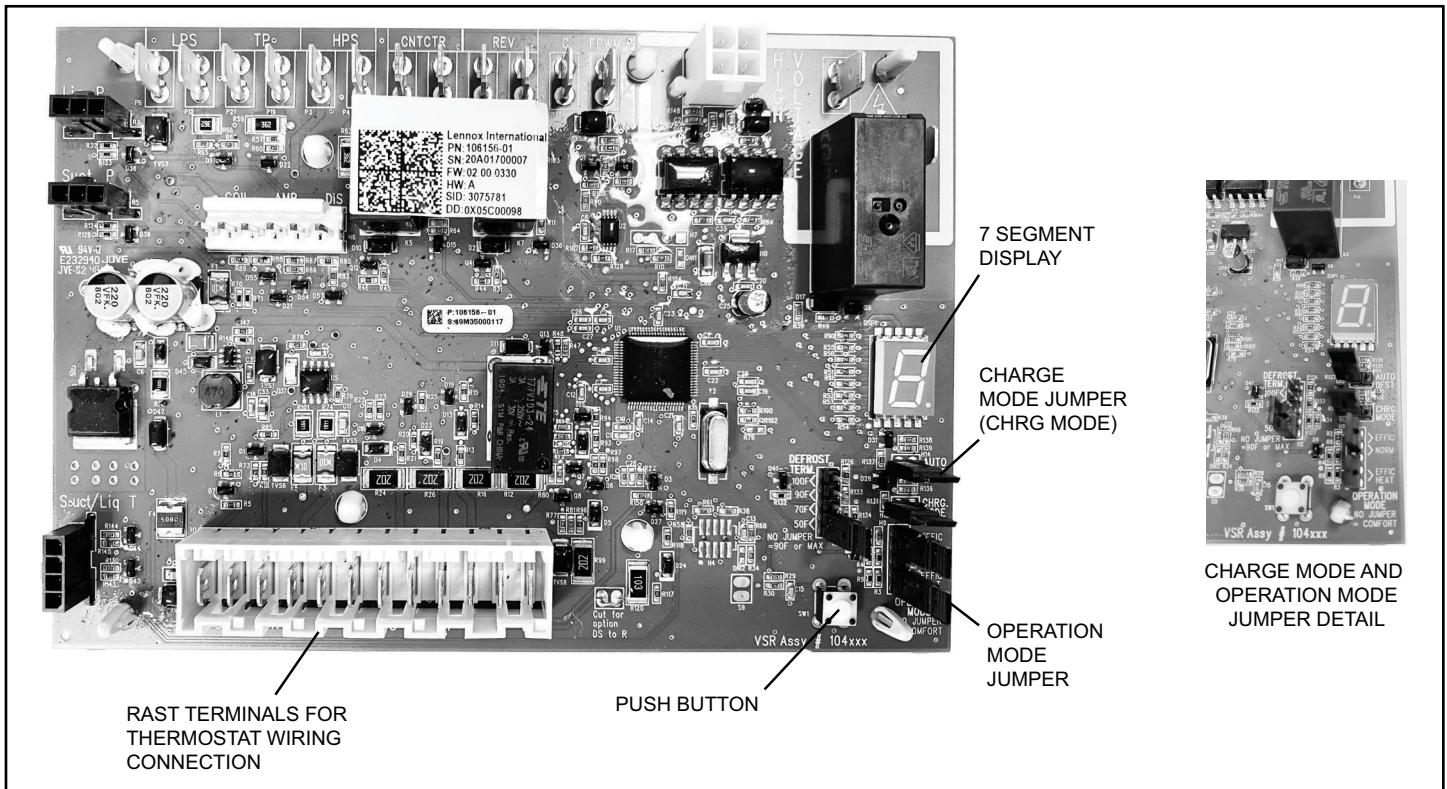

Figure 11.

### 7-Segment Display and Push Button

Information labels concerning the outdoor control 7-segment display and push button operations are available on the unit control panel cover.

### Alarms

Alarm information is provided on the unit control panel cover.

### Programming Unit Type

Programming to the appropriate tonnage allows the unit to operate in the range of compressor and fan speeds that are optimized for best unit performance and efficiency.

The HRG18 units are programmed from the factory to function in 3 Ton and 5 Ton modes of operation. If the intended capacity for the application is 3 or 5 Ton, skip this section.

The units are field convertible to 2 Ton or 4 Ton to efficiently perform for the required application. If the intended capacity is 2 or 4 Ton, proceed to the following steps to program the unit type. Outdoor unit must be powered ON and in idle mode (no heating or cooling mode of operation).

**NOTE:** The -36 unit can be programmed to operate as a 2 Ton, and the -60 unit can be programmed to operate as a 4 Ton.

Perform the following steps to program the unit type.

1. To enter mode options, push and hold the push button next to the seven-segment display until a DASH (-) symbol appears. Immediately release the button. Once the dash starts blinking, proceed to the next step.



2. Push and hold button again until PU is displayed on the seven-segment display. Immediately release the button.

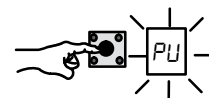

3. Push and hold button until the code for the correct unit type is displayed.

Unit Code	Unit Type
58	2 Ton
60	3 Ton
62	4 Ton
63	5 Ton

Table 6. Unit Tonnage Codes

- The unit will display the unit type for 10 seconds. Press the push button and hold it for 3 seconds for the unit to store the unit type. Once, the unit code is stored the system acknowledges by displaying a string of characters ending with the updated system unit code.

After programming of unit type is complete, the unit can be set up for charge mode operation.

### Charge Mode Jumper

To initiate the HRG18 Charge Mode function, install the jumper across the two Charge Mode Pins (CHRG MODE) on the outdoor control. The Charge Mode can be used when charging the system with refrigerant, checking the refrigerant charge, pumping down the system and performing other service procedures that requires outdoor unit operation at 100% capacity.

### ***HRG18 Charge Mode Operation with a Conventional 24VAC Non-Communicating Heat Pump Thermostat***

#### **Charge Mode Jumper Operation in the Cooling Mode**

On applications with a conventional 24VAC non-communicating heat pump thermostat, the charge mode jumper must be installed on the Charge Mode Pins after providing a cooling compressor demand to the HRG18 and an "O" cooling reversing valve demand to initiate the Charge Mode. A cooling blower demand must also be provided to initiate blower in high stage operation on the indoor unit.

The compressor and outdoor fan motor will begin to ramp up and reach 100% design capacity within 3 minutes. They will continue to operate at 100% design capacity for the duration of charge mode.

#### **Charge Mode Jumper Operation in the Heat Pump Heating Mode**

On applications with a conventional 24VAC non-communicating heat pump thermostat, the charge mode jumper must be installed on the Charge Mode Pins after providing a heating compressor demand to the HRG18 without an "O" reversing valve signal to initiate the Charge Mode. A heating blower demand must also be provided to initiate high speed blower operation on the indoor unit.

The compressor and outdoor fan motor will begin to ramp up and reach 100% design capacity within 3 minutes. They will continue to operate at 100% design capacity for the duration of charge mode.

#### **Exiting Charge Mode**

To exit the charging mode, remove the Charge Mode Jumper from the Charge Mode Pins. The system will be in Charge Mode for a maximum time of 60 minutes and will automatically exit the charge mode and resume normal operation after 60 minutes even if the charge mode jumper is left in place. To extend the charge mode beyond

60 minutes, ensure the cooling/heating demand, blower demand and appropriate reversing valve demand are available and reapply the charge mode jumper.

**NOTE:** *If compressor demand is lost during charge mode period, then the compressor and fan will cease to operate, and the unit will enter into a delay timer for 3 minutes. Repeat the charging mode procedure to get back into charge mode.*

## Start-Up

### CAUTION

If unit is equipped with a crankcase heater, it should be energized 24 hours before unit start-up to prevent compressor damage as a result of slugging.

- Rotate fan to check for frozen bearings or binding.
- Inspect all factory and field-installed wiring for loose connections.
- After evacuation is complete, open liquid line and suction line service valves to release refrigerant charge (contained in outdoor unit) into system.
- Replace the stem caps and secure finger tight, then tighten an additional 1/6 of a turn.
- Check voltage supply at the disconnect switch. The voltage must be within the range listed on the unit nameplate. If not, do not start equipment until the power company has been consulted and the voltage condition corrected.
- Set thermostat for cooling demand, turn on power to indoor blower, and close the outdoor unit disconnect switch to start the unit.
- Recheck unit voltage with unit running. Power must be within range shown on unit nameplate.

## Refrigerant Charging

### CAUTION

Excessive amounts of liquid refrigerant entering the suction line can damage the compressor. When adding refrigerant, precautions must be taken to control the flow of liquid into the system. This can be done by using a liquid vaporizing adapter or manual control using a sight glass as indicator.

Units are factory charged with the amount of R-410A refrigerant indicated on the unit rating plate. This charge is based on a matching indoor coil and outdoor coil with 15' line set. For varying lengths of line set, refer to Table 7 for refrigerant charge adjustment. A blank space is provided on the unit rating plate to list the actual field charge.

Liquid Line Set Diameter	Oz. Per 5 ft. adjust from 15 ft. line set*
3/8 in.	3 oz. per 5 ft. or 0.6 oz. per 1 ft.
* If line length is greater than 15 ft., add this amount. If line length is less than 15 ft., remove this amount.	

**Table 7. Refrigerant Charge Adjustment**

**! IMPORTANT**

Mineral oils are not compatible with R-410A. If oil must be added, it must be a polyolester oil.

**NOTE:** Both airflow and refrigerant charge must be monitored for proper system set-up. It may be necessary to alternately check and adjust the airflow and the refrigerant charge.

If the system is void of refrigerant, or if the outdoor ambient temperature is cool, use the weigh-in method to charge the unit. Do this after any leaks have been repaired.

1. Recover the refrigerant from the unit.
2. Conduct a leak check, then evacuate as previously outlined.
3. Weigh in the charge according to the total amount shown on the unit nameplate.

If weighing facilities are not available or if unit is being charged during warm weather, use one of the following procedures.

- **For systems using a TXV on the indoor evaporator and outdoor temperature above 60°F** – charge in cooling mode using the subcooling method and table provided on the unit access panel.
- **For systems below 60°F** – charge in heating mode using the subcooling method and table provided on the unit access panel. Attach low pressure gauge hose to auxiliary service port to access suction side in heating mode.

**NOTE:** All unit table values are based on 70 to 80°F indoor return air temperature for cooling mode, and 65°F to 75°F return air temperature for heat mode.

**High Pressure Switch**

This unit is equipped with a high pressure switch which is located on the liquid line. The SPST, normally closed pressure switch opens when liquid line pressure rises above the factory setting of 590 +/- 15 psig and automatically resets at 418 +/- 15 psig.

**Torque Requirements**

When servicing or repairing HVAC components, ensure the fasteners are appropriately tightened. Table 8 shows torque values for fasteners.

Fastener	Torque
Valve Stems	4 in. lbs.
Stem Caps	8 ft. lbs.
Service Port Caps	8 ft. lbs.
Sheet Metal Screws	16 in. lbs.
#8 Machine Screws	16 in. lbs.
#10 Machine Screws	28 in. lbs.
Compressor Bolts	90 in. lbs.

**Table 8. Torque Table**

**Liquid and Suction Line Service Valves**

The liquid line and suction line service valves (see Figure 12) and service ports are used for leak testing, evacuation, charging, and checking charge.

Each valve is equipped with a service port which has a factory-installed Schrader valve. A service port cap protects the Schrader valve from contamination and serves as the primary leak seal.

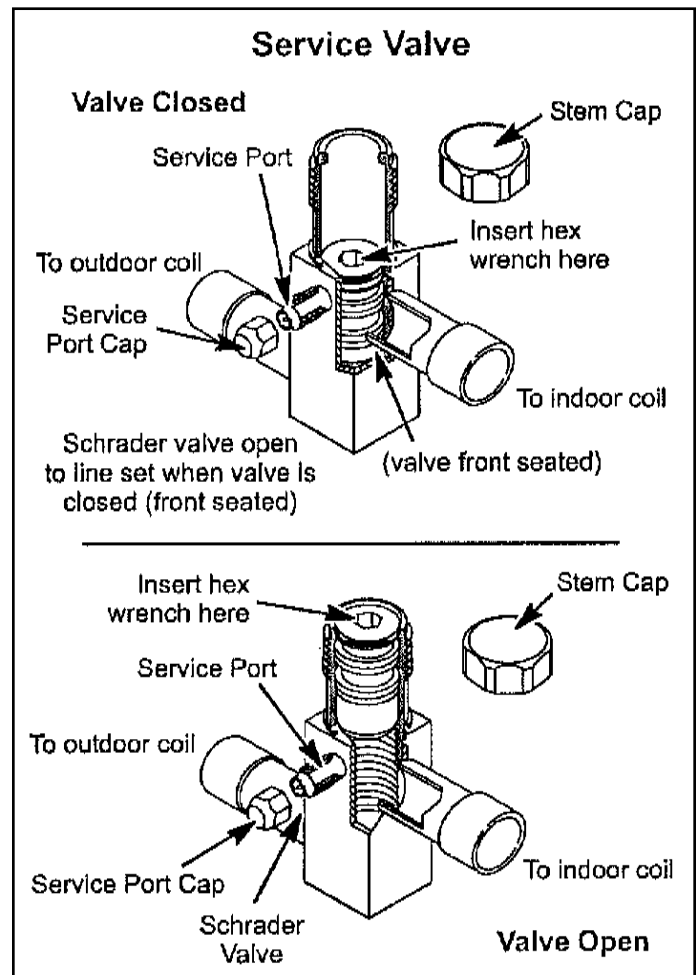

**Figure 12.**

**To Access the Schrader Port:**

1. Remove the service port cap with an adjustable wrench.

**Maintenance**

2. Connect gauge to the service port.
3. When testing is completed, replace service port cap. Tighten finger tight, then an additional 1/6 turn.

**To Open Liquid or Suction Line Service Valve:**

1. Remove stem cap with an adjustable wrench.
2. Use service wrench with a hex-head extension to back the stem out counterclockwise as far as it will go. Use a 3/16" hex head extension for liquid line service valves and a 5/16" extension for suction line service valves.
3. Replace the stem cap. Tighten finger tight, then tighten an additional 1/6 turn.

**To Close Liquid or Suction Line Service Valve:**

1. Remove the stem cap with an adjustable wrench.
2. Use a service wrench with a hex-head extension to turn the stem clockwise to seat the valve. Tighten firmly.
3. Replace the stem cap. Tighten finger tight, then tighten an additional 1/6 turn.

**Suction Line (Ball Type) Service Valve**

Suction line (ball type) service valves function the same way as the other valves; the difference is in the construction (see Figure 13).

The ball valve is equipped with a service port with a factory-installed Schrader valve. A service port cap protects the Schrader valve from contamination and serves as the primary seal.

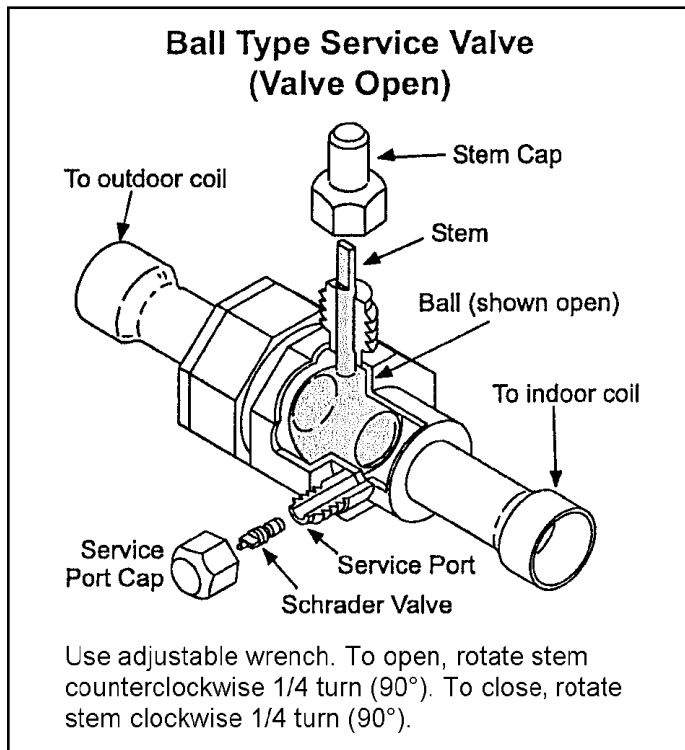

**Figure 13.**

**Regular Maintenance Requirements**

Your system should be regularly inspected by a qualified service technician. These regular visits may include (among other things) checks for:

- Motor operation
- Ductwork air leaks
- Coil & drain pan cleanliness (indoor & outdoor)
- Electrical component operation & wiring check
- Proper refrigerant level & refrigerant leaks
- Proper airflow
- Drainage of condensate
- Air filter(s) performance
- Blower wheel alignment, balance & cleaning
- Primary & secondary drain line cleanliness
- Proper defrost operation (heat pumps)

**Air Filter**

Inspect air filters at least monthly and replace or clean as required. Disposable filters should be replaced. Washable filters may be cleaned by soaking in mild detergent and rinsing with cold water. Allow filter to dry before reinstalling. Replace filters with the arrows pointing in the direction of airflow. Dirty filters are the most common cause of poor heating / cooling performance and compressor failures.

**Indoor Coil**

If the system has been operated with a clean filter in place, it should require minimal cleaning. If cleaning is needed, call your dealer for service.

**Condensate Drain**

During cooling season check at least monthly for free flow of drainage and clean if necessary.

**Outdoor Unit**

Grass cuttings, leaves, dirt, dust, lint from clothes dryers, and foliage from trees can be drawn into coils by movement of the air. Clogged condenser coils will lower the efficiency of your unit and could cause damage to the condenser and compressor.

Periodically, debris should be brushed from the condenser coils. Use a soft bristle brush with light pressure only. DO NOT damage or bend condenser coil fins. Damaged or bent fins may affect unit operation.

**⚠ WARNING**

**SHARP OBJECT HAZARD!**

Condenser coils have sharp edges. Wear adequate body protection on body extremities (e.g. gloves).

**FAILURE TO FOLLOW THIS WARNING COULD RESULT IN BODILY INJURY.**

**Painted Surfaces**

For maximum protection of the unit's finish, a good grade of automobile wax should be applied every year. In geographical areas where water has a high concentration of minerals (calcium, iron, sulfur, etc.), it is recommended that lawn sprinklers not be allowed to spray the unit. In such applications, the sprinklers should be directed away from the unit. Failure to follow this precaution may result in premature deterioration of the unit finish and metal components.

In sea coast areas, special maintenance is required due to the corrosive atmosphere provided by the high salt concentration in ocean mists and the air. Periodic washing of all exposed surfaces and coil will add life to your unit. Please consult your installing dealer for proper procedures in your geographic area.

**Homeowner Information**

**⚠ WARNING**

**ELECTRICAL SHOCK HAZARD!**

Turn OFF electric power to unit before performing any maintenance or removing panels or doors.

**FAILURE TO DO SO COULD RESULT IN BODILY INJURY OR DEATH.**

**Heat Pump Operation**

Your new heat pump has several characteristics that you should be aware of:

- Heat pumps satisfy heating demand by delivering large amounts of warm air into the living space. This is quite different from gas-or oil-fired furnaces or an electric furnace which deliver lower volumes of considerably hotter air to heat the space.
- Do not be alarmed if you notice frost on the outdoor coil in the winter months. Frost may develop on the outdoor coil during the heating cycle when temperatures are below 45°F. An electronic control activates a defrost cycle lasting 5 to 15 minutes at preset intervals to clear the outdoor coil of the frost.
- During the defrost cycle, you may notice steam rising from the outdoor unit. This is a normal occurrence. The thermostat may engage auxiliary heat during the

defrost cycle to satisfy a heating demand; however, the unit will run to normal operation at the conclusion of the defrost cycle.

***In case of extended power outage...***

If the outdoor temperature is below 50°F and power to your outdoor unit has been interrupted for one hour or longer, observe the following when restoring power to your heat pump system.

- Set the room thermostat selector to the "Emergency Heat" setting to obtain temporary heat for a minimum of 6 hours. This will allow system refrigerant pressures and temperatures enough time to return to a stabilized condition.
- In Emergency Heat mode, all heating demand is satisfied by auxiliary heat; heat pump operation is locked out. After a 6 hour "warm-up" period, the thermostat can then be switched to the "Heat" setting and normal heat pump operation may resume.

**Thermostat Operation**

The wall-mounted thermostat controls your heat pump. The thermostat is available in various configurations from different manufacturers. The information below is typical for most thermostats. Ask your dealer for specific information regarding the model of thermostat installed.

**Fan Switch**

In AUTO or INT (intermittent ) mode, the blower operates only when the thermostat calls for heating or cooling. This mode is generally preferred when humidity control is a priority.

The ON or CONT mode provides continuous indoor blower operation, regardless of whether the compressor or auxiliary heat are operating. This mode is required when constant air circulation or filtering is desired.

On models without a fan selection switch, the fan will cycle with the outdoor unit.

**System Switch**

Set the system switch for heating, cooling or auto operation. The auto mode allows the heat pump to automatically switch from heating mode to cooling mode to maintain predetermined comfort settings. Many heat pump thermostats are also equipped with an emergency heat mode which locks out heat pump operation and provides temporary heat supplied by the auxiliary heat.

**Indicating Light**

Most heat pump thermostats have an amber light which indicates when the heat pump is operating in the emergency heat mode.

**Temperature Indicator**

The temperature indicator displays the actual room temperature.

### ***Programmable Thermostats***

Your system may be controlled by a programmable thermostat. These thermostats provide the added feature of programmable time-of-day set points for both heating and cooling. Refer to the user's information manual provided with your particular thermostat for operation details.

### **Important System Information**

- Your system should never be operated without a clean air filter properly installed.
- Return air and supply air registers should be free from restrictions or obstructions to allow full flow of air.

### **IF YOUR SYSTEM DOES NOT WORK, BEFORE REQUESTING A SERVICE CALL:**

1. Ensure thermostat is set below (cooling) or above (heating) room temperature and that the system lever is in the "COOL", "HEAT" or "AUTO" position.
2. Inspect your return air filter: If it is dirty, your heat pump may not function properly.
3. Check indoor and outdoor disconnect switches. Confirm circuit breakers are ON or that fuses have not blown. Reset breakers/replace fuses as necessary.
4. Inspect the outdoor unit for clogged condenser coils, (grass cuttings, leaves, dirt, dust or lint). Ensure that branches, twigs or other debris are not obstructing the condenser fan.

### **IF YOUR SYSTEM STILL DOES NOT OPERATE, CONTACT YOUR SERVICING DEALER.**

Be sure to describe the problem, and have the model and serial numbers of the equipment available.

If warranty replacement parts are required, the warranty must be processed through a qualified distribution location.

- NOTES:
1. NOTE-FOR USE WITH COPPER CONDUCTORS ONLY. REFER TO UNIT RATING PLATE FOR MINIMUM CIRCUIT AMPACITY AND MAXIMUM OVERCURRENT PROTECTION SIZE.
  2. WARNING-ELECTRIC SHOCK HAZARD CAN CAUSE INJURY OR DEATH. UNIT MUST BE GROUNDED IN ACCORDANCE WITH NATIONAL AND LOCAL CODES.
  3. REFER TO COMPRESSOR IN UNIT FOR ACTUAL TERMINAL ARRANGEMENT.
  4. NOTE-IF ANY WIRE IN THE APPLIANCE IS REPLACED, IT MUST BE REPLACED WITH WIRE OF LIKE SIZE, RATING, INSULATION THICKNESS AND TERMINATION.

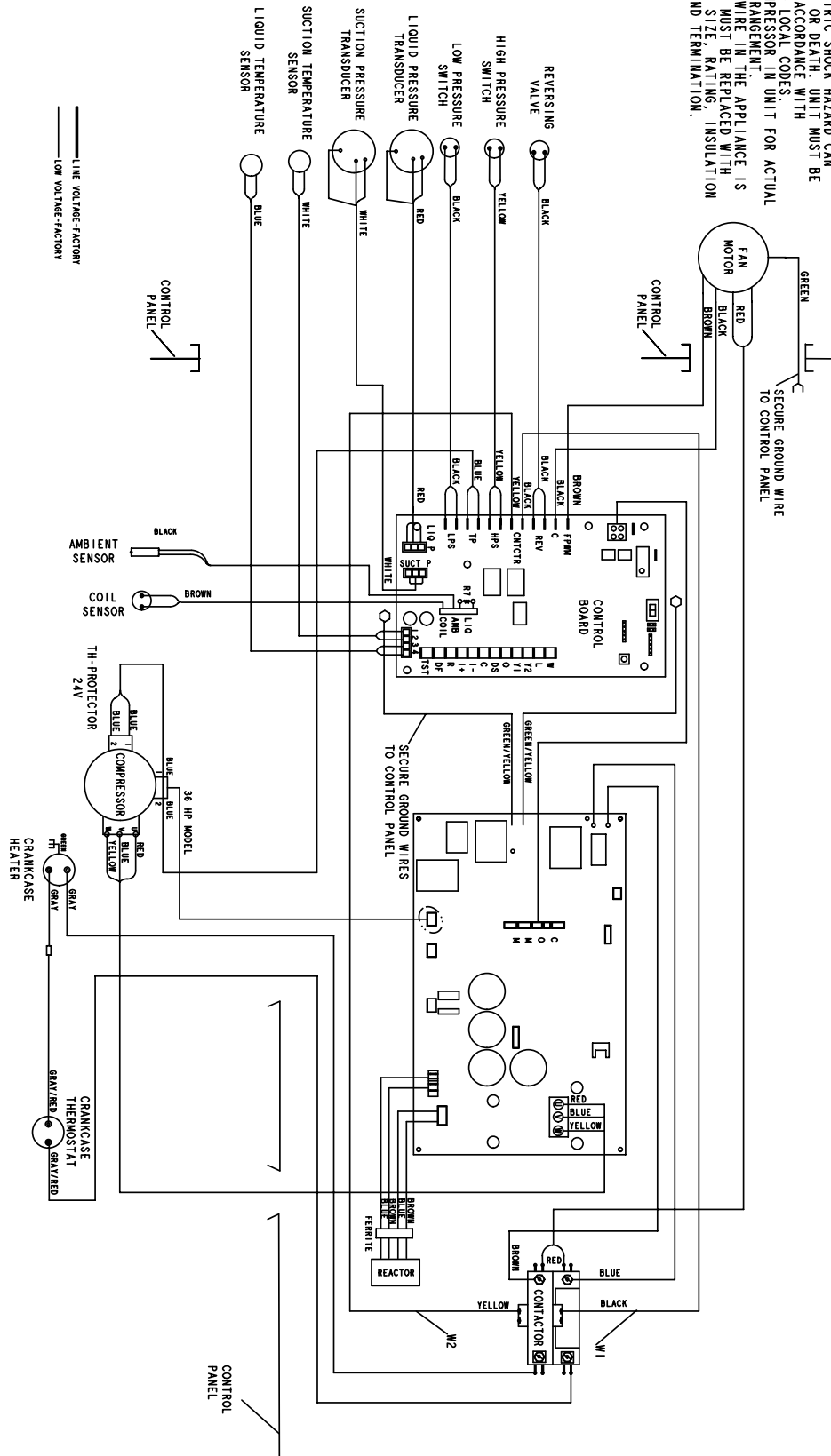

Figure 14. Wiring Diagram

# Addendum

## to HRG18

### Installation Instructions

The low-voltage field connection harness has temporarily changed on the HRG18 units due to availability of the wiring harness connectors from our supplier. The low-voltage field wiring connection harness is provided with leads with stripped ends in the low-voltage make-up box for field connections using wire nuts.

- Connect the low-voltage field wiring to the stripped low-voltage field wiring harness leads using wire nuts.
- The field wiring connections are color coded and stamped with the terminal designation every couple of inches along the wire. See the HRG18 tables on page 1 and 2.
- Install a wire nut on any unused wire to electrically insulate the unused wire.

Field Connection Wire Harness Wire Color	Marking Stamped on the Wire	Thermostat Wire Connection	Notes
Light Blue	TST	TST	Not used. Install a wire nut on this wire.
Light Blue	DF	DF	Not used. Install a wire nut on this wire.
Red	R	R	R (24VAC Power); Used with A3 Comfort Sync® thermostat and 24V conventional thermostats
Purple	i+	i+	Used with A3 Comfort Sync® thermostat only. Install wire nut on this wire if unused.
Gray	i-	i-	Used with A3 Comfort Sync® thermostat only. Install wire nut on this wire if unused.
Black	C	C	C (24VAC Common); Used with A3 Comfort Sync® thermostat and 24V conventional thermostats

**Table 1. HRG18 Thermostat Wiring Low Voltage Field Connection Harness #1**



Field Connection Wire Harness Wire Color	Marking Stamped on the Wire	Thermostat Wire Connection	Notes
Pink	DS	DS	Not used. Install a wire nut on this wire.
Orange	O	O	HRG18 heat pump reversing valve on installations with conventional non-communicating thermostat. Install a wire nut on this wire if unused.
Yellow	Y1	Y1	Y1 first stage cooling with conventional non-communicating thermostat only. Install a wire nut on this wire if unused.
Blue	Y2	Y2	Y2 second stage cooling with conventional non-communicating thermostat only. Install a wire nut on this wire if unused.
Brown	L	L	Optional load shed input. Install a wire nut on this wire if unused.
White	W	W	HRG18 heat pump defrost heat output on installations with conventional non-communicating thermostat. Install a wire nut on this wire if unused.

**Table 2. HRG18 Thermostat Wiring Low Voltage Field Connection Harness #2**

**HRG18 HFC-410A CHARGING INFORMATION - FOR COMPLETE CHARGING PROCEDURES, REFER TO THE APPLICABLE INSTALLATION AND SERVICE MANUAL**

**TABLE - 1 NORMAL OPERATING PRESSURES (LIQUID ±10 AND SUCTION ±5 psig)**

HRG18 °F	HEATING OPERATION - MAX SPEED				
	2 TON MODE	3 TON MODE	4 TON MODE	5 TON MODE	5 TON MODE
	LIQUID LINE PRESSURE / VAPOR LINE PRESSURE				
20	287/65	275/51	342/59	326/53	
30	329/78	318/69	345/67	347/62	
40	367/92	340/76	376/82	364/75	
50	379/110	358/96	407/99	374/92	
60	397/129	375/113	422/118	392/110	
	COOLING OPERATION - MAX SPEED				
65	230/143	247/128	236/134	237/121	
70	245/144	270/132	255/136	258/124	
75	266/144	291/136	276/135	278/126	
80	287/145	318/141	297/136	299/127	
85	309/147	338/142	319/138	322/128	
90	332/149	362/144	344/138	345/129	
95	356/149	393/145	368/140	370/129	
100	383/151	415/147	392/143	396/130	
105	410/152	432/148	418/146	423/132	
110	433/154	471/150	422/147	452/133	
115	468/155	506/150	473/148	479/135	

Maintenance checks using the Normal Operating Pressures table. This table is not a procedure for charging the system. Minor variations in the pressures can be expected due to differences in installations. However, significant deviations could mean that the system is not properly charged or that a problem exists with some component in the system.

**Matched System Components/Charge Levels/Line Set Length/Liquid Line Sizing**  
Table 2 lists all the Lennox recommended indoor unit matches along with the charge levels for the various sizes of outdoor units. Charge levels on the unit nameplate are based on installations with 15' (4.6m) line sets; consider line set length and liquid line sizing differences when calculating charge adjustments. For each additional foot of 3/8" liquid line set, add 0.6 ounces or for 1/2" liquid lines, add 1.0 ounce of additional charge.

**Charge Using the Weigh-in Method**  
If the system is void of refrigerant, locate and repair any leaks and then weigh in the refrigerant charge into the unit. For charge adjustments, be sure to consider line set length differences and, referring to table 2, adjust for the match-up difference.

1 - Recover the refrigerant from the unit.  
2 - Conduct leak check; evacuate the system.  
3 - Weigh in the unit nameplate charge, adjusting for match-up and line set length differences. If weighing facilities are not available use the Subcooling method.

**Charge Using the Subcooling Method**  
**Cooling Mode**-When the outdoor ambient temperature is 60°F (15°C) and above, use the cooling mode to adjust the charge using the subcooling method. Target subcooling values in table 2 are based on 70 to 80°F (21-27°C) indoor return air temperature.

**Heating Mode**-When the outdoor ambient temperature is below 60°F (15°C), use the heating mode to adjust the charge using the subcooling charge levels (table). Target subcooling values in table 2 are based on 65-75°F (18-24°C) indoor return air temperature.

**TABLE - 2 INDOOR UNIT MATCHUPS AND SUBCOOLING CHARGE LEVELS**

INDOOR MATCHUP	SUBCOOL		INDOOR MATCHUP	INDOOR MATCHUP	SUBCOOL		ADDNL CHARGE LBS/OZ
	HEATING (±5°F)	COOLING (±1°F)			HEATING (±5°F)	COOLING (±1°F)	
	2 TON MODE		4 TON MODE		5 TON MODE		
HMG24*IP / HCG24VIP	36	9	HMG48*IP / HCG48VIP	23.5	6	8 OZ	
HMG30*IP / HCG30VIP	29	10					
	3 TON MODE		6 TON MODE		7 OZ		
HMG36*IP / HCG36VIP	15	11	HMG60*IP / HCG60VIP	13	6	7 OZ	
HMG42*IP / HCG42VIP	16	8					



INDOOR MATCHUP	SUBCOOL		INDOOR MATCHUP	INDOOR MATCHUP	SUBCOOL		ADDNL CHARGE LBS/OZ
	HEATING (+/- 5°F)	COOLING (+/- 1°F)			HEATING (+/- 5°F)	COOLING (+/- 1°F)	
	2 TON MODE		4 TON MODE		5 TON MODE		
(C,M)CG24P(A,B,C)4P	28	7	(C,M)CG48P(C,D)CP	18	9	1 LB / 15 OZ	
(C,M)CG24T(A,B,C)4P			(C,M)CG60P(C,D)AP	15.5	6.5	10 OZ	
(C,M)CG3036P(A,B,C)4P			(C,M)CG60T(C,D)AP				
(C,M)CG3036T(A,B,C)4P							
(C,M)CG30P(A,B,C)5P	16	4	(C,M)CG60P(C,D)AP	15.5	8.5	10 OZ	
(C,M)CG30T(A,B,C)5P			(C,M)CG60T(C,D)AP	16	7.5	1 LB / 4 OZ	
	3 TON MODE						
(C,M)CG36P(A,B,C)7P	26	18.5	(C,M)CG60T(C,D)BP				
(C,M)CG36T(A,B,C)7P			(C,M)CG60T(C,D)BP				

\*Amount of charge required in addition to charge shown on unit nameplate. (Remember to consider line set length.)

---

Due to ongoing product improvements, specifications and dimensions are subject to change and correction without notice or incurring obligations. Determining the application and suitability for use of any product is the responsibility of the installer. Additionally, the installer is responsible for verifying dimensional data on the actual product prior to beginning any installation preparations.

Incentive and rebate programs have precise requirements as to product performance and certification. All products meet applicable regulations in effect on date of manufacture; however, certifications are not necessarily granted for the life of a product. Therefore, it is the responsibility of the applicant to determine whether a specific model qualifies for these incentive/rebate programs.

*Comfort-Cire*®  **Century**®

1900 Wellworth Avenue • Jackson, MI 49203 • 517-787-2100