



MB COMPACT HIGH-CAPACITY SERIES

PRODUCT CATALOG

Part#: LC3011 | Revised: March 25, 2026

Models: MB 072-300
60 Hz - R-454B

Table of Contents

Models:
MB
072-300

3	Introduction	58	Physical Data
4	Features, Options, and Accessories	60	Waterside Economizer (WSE)
5	Intelligent Communicating Controls	60	Performance Data
6	Internal Variable Water Flow Control	61	Entering Air Corrections
7	Selection Procedure	64	Cooling Corrections
10	Model Nomenclature	66	Airflow Ratings
11	Performance Data	68	Dimensional Data
11	AHRI/ASHRAE/ISO 13256-1	68	MB072-120 Horizontal
13	Selection Notes	69	MB072-120 Horizontal with WSE
14	Performance Data	70	MB072-120 Vertical
28	Corrections	71	MB072-120 Vertical with WSE
28	Airflow, Cooling, and Heating Tables	72	MB168-240 Vertical
29	Antifreeze Tables	73	MB168-240 Vertical with WSE
31	Motorized Water Valve and Modulating Valve Adders	74	MB300 Vertical
32	Blower Performance	75	MB300 Vertical with WSE
54	Electrical Data	76	Minimum Installation Area
54	Standard	77	Blower Motor Variable Frequency Drive
56	Dual Point Power	79	Engineering Specifications
		85	Revision History

THE MB COMPACT HIGH-CAPACITY SERIES

The MB Compact High-Capacity Series raises the bar for water-source heat pump efficiencies, features and application flexibility. Not only does the MB exceed ASHRAE 90.1 efficiencies, but it also uses R-454B low Global Warming Potential (GWP) refrigerant, making it an extremely environmentally friendly space conditioning product solution. The MB is eligible for additional LEED® (Leadership in Energy and Environmental Design) points due to its innovative and environmentally conscious design. With one of the smallest cabinets in the industry, the MB easily fits into tight spaces including standard doorways. Designed to be backward compatible with older water-source heat pumps, the MB heat pump is packed full of the innovation you have come to expect from our experts.

Available in sizes 6 tons (21.1 kW) through 25 tons (87.9 kW) with multiple cabinet configurations, the MB offers a wide range of units designed for most applications. The MB has an extended range refrigerant circuit, capable of ground-loop (geothermal) applications (may require optional extended range insulation), ground-water (geothermal) applications, as well as water-loop (boiler-tower) applications. Microprocessor controls, galvanized-steel cabinet, galvanized-steel with epoxy powder-coated drain pan and TXV refrigerant metering device are just some of the features of the flexible MB series.

Recent EPA mandates require an industry transition to low-GWP refrigerants, such as R-454B which is a gas that is classified as having low-toxicity, low-flammability rating. Due to these characteristics, R-454B systems charged with over 62 ounces of refrigerant must contain an integrated Refrigerant Detection System (RDS). In the unlikely event of a system-refrigerant leak, the RDS shuts down compressor operation and runs the unit blower motor to disperse any concentration of leaked refrigerant in compliance with UL 60335-2-40 safety standards.

Options such as a coated air coil, DDC controls, and dual-point power allow customized design solutions. Optional variable-frequency blower motor controls or blower-motor/sheave-drive packages expand the operating range and help overcome some of the challenges associated with ductwork for retrofit installations. A sound-absorbing Sound Attenuation package makes a great unit even better.

Intelligent communicating controls provide technicians an interface into the operation of the system in real time without the need for hard tooling. On-board advanced controls communicate the key operating system temperatures enabling technicians to startup, commission, and service the equipment via Wireless Service Tool. Communicating controls also enable system adjustments and capture operating conditions at time of fault. All this information is displayed in an easy-to-read format maximizing the usability of the experience.

Waterside Economizers (WSE) take advantage of cool loop-water temperatures and can provide for free cooling. In shoulder seasons, lower building loop temperatures can be leveraged when there is cooling demand by adding a factory installed hydronic coil. The WSE option meets IECC section C403.3.1 and is a requirement in many states.

The MB series water-source heat pumps are designed to meet the challenges of today's HVAC demands with one of the most innovative products available on the market.

FEATURES

- Horizontal sizes 072 (6 Tons, 21.1 kW) through 120 (10 Tons, 35.2 kW)
- Vertical sizes 072 (6 Tons, 21.1 kW) through 300 (25 Tons, 87.9 kW)
- Environmentally friendly R-454B low-GWP refrigerant
- Refrigerant Detection System (RDS) (required for all sizes)
- Horizontal configurations with left or right return-air and straight or back supply air discharge. Discharge is field convertible. Field conversion uses all existing parts, including panels and belts
- Vertical configurations with front or back return and top, front, or back discharge. Fan discharge on vertical unit sizes 072-120 is field convertible. Field conversion uses all existing parts, including panels and belts
- Electric power entry points from either side of the front
- Configurable water connections for left or right handling on horizontal units
- Dual refrigeration circuits (all sizes)
- Exceeds ASHRAE 90.1 efficiencies
- Galvanized-steel cabinet construction
- Insulated divider and separate compressor/air handler compartments
- TXV metering device
- Standard hanger brackets for horizontal units
- Premium-duty motor that is VFD compatible
- CXM2 Communicating Controls:
 - Connect directly to the system with a Wireless Service Tool
 - Provides real-time unit operating conditions
 - Reduces startup, commissioning, and service time by providing key system temperatures electronically
 - Captures operating conditions in the event of a safety shutdown

OPTIONS

- Variable Frequency Drive (VFD) fan-motor controls (single-zone VAV compatible)
- Blower motor/sheave drive packages
- BACnet, Modbus, and Johnson Controls N2 compatibility options for Building Management Systems (BMS)
- Sound-absorbing Sound Attenuation package
- Coated air coil
- Dual-point power
- Waterside Economizer (WSE): requires a heat-pump thermostat with two-stage cooling
- Extended-range insulation for geothermal applications
- Factory-configurable water connections for left or right handling on vertical units
- Motorized and modulating water valves for ultimate part-load operation (vertical units)
- Cupronickel heat exchangers

ACCESSORIES

- Wide variety of thermostat options to meet your application needs
- Braided-hose kits in various lengths with optional water valve, PT plugs, blowdown valve, flow regulator, and strainer
- Externally mounted manual and motorized water valves
- 1-inch Merv 8 filter
- 2-inch Merv 8 or 13 filters
- Aesthetically pleasing wall sensors for connection to BMS (MPC) controls

AN INFORMATION GATEWAY TO MONITOR, CONTROL, AND DIAGNOSE YOUR SYSTEM

Our communicating water-source heat pump offers an information gateway into the system. This allows users to interact with their system in clear language, delivering improved reliability and efficiency by monitoring and controlling the system. This makes our water-source heat pumps easy to install and service.

Monitor/Configure – Installers can configure from the configuration/diagnostic tool, unit family, size, accessory configuration, and demand reduction (optional, to limit unit operation during peak times). Users can look up the current system status, temperature sensor readings, and operational status of the blower.

Precise Control – CXM2 Exclusive - Intelligent, 2-way communication between the CXM2 and smart components like the optional Variable Frequency Drive (VFD) fan-motor. The CXM2 uses information received from the smart components and sensors to precisely control unit operation to deliver higher efficiency, reliability and increased comfort.

Diagnostics – While in Service mode, technicians can access fault description, possible causes and most importantly, the conditions (temp, flow, i/o conditions, configuration) at the time of the fault. Manual Operation mode allows technicians to manually command operation for any of the thermostat outputs, blower speed, to help troubleshoot specific components.

With communicating controls, technicians have a gateway to system information never before available to our water-source heat pump products.

CXM2 Communicating Controls

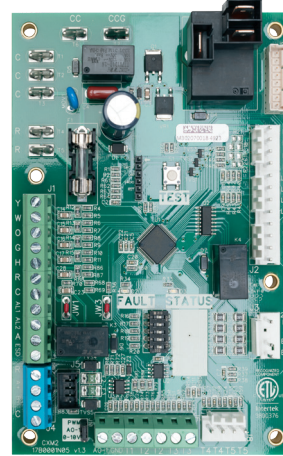

Wireless Service Tool Web Application

Devices	
<ul style="list-style-type: none"> Unit - Primary <ul style="list-style-type: none"> Settings Diagnostics Fault History Fault History 1 Fault History 2 Fault History 3 Fault History 4 Fault History 5 Reporting System Flow Manual Operation 	<ul style="list-style-type: none"> Fault Code Low air coil pressure Operating Mode Cooling Stage 2 Entry Date 9/12/2024 4:31:00 PM Water Coil Liquid Temperature 92.2 F Air Coil Liquid Temperature 50.1 F Entering Water Temperature 95.2 F Leaving Water Temperature (Source) 103.2 F Compressor Discharge Temperature 195 F Control Voltage 24.8 V Cool Setpoint Temperature 73 F Dehumidification Setpoint 65 % Heat Setpoint Temperature 71 F
<ul style="list-style-type: none"> Thermostat <ul style="list-style-type: none"> Settings 	
<ul style="list-style-type: none"> Refrigerant Detection System <ul style="list-style-type: none"> Diagnostics 	
<ul style="list-style-type: none"> Tool Configuration Logging 	

INTERNAL VARIABLE WATER FLOW

Industry-first, built-in Variable Water Flow replaces a traditionally inefficient, external component of the system (water circulation) with an ultra-high-efficient, variable-speed, internal water-flow system. This saves 70-80% on water circulation compared to traditional single-speed pump systems. Multi-unit installations are also much simpler with Variable Water Flow systems, as the units automatically adjust water flow across the system.

Variable Water Flow is enabled by Intelligent Controls, which facilitates intelligent communication between the thermostat, CXM2, sensors, and internal water pump/valve to make true variable water flow a reality.

VALVE

- **Low System Pressure Drop Modulating Valve:** High CV motorized valve for central pumping. (Standard unit).

BENEFITS

Easier and quicker unit installation as the flow control is built in to the unit.

- Superior reliability by varying the water flow to deliver more stable operation.
- Increased cost savings by varying the flow (and pump watt consumption) to match the unit's mode of operation.

INTERNAL COMPONENTS

Our water-source heat pumps can be installed more easily and compactly than their predecessors because Variable Water Flow components are internal to the unit. They also save installing contractors labor and time by eliminating the need for an external flow regulator or a bulky external pumping module.

VARIABLE FLOW

Variable Water Flow technology enables variable water flow through the unit, with the CXM2 adjusting the motorized valve to maintain an installer-set loop DT. By controlling the water flow, the system is able to operate at its optimal capacity and efficiency.

The motorized modulating valve delivers variable water flow, controlled by CXM2, based on loop water DT.



Reference Calculations

Heating	Cooling
$LWT = EWT - \frac{HE}{GPM \times \text{Constant}}$	$LWT = EWT + \frac{HR}{GPM \times \text{Constant}^1} \quad LC = TC - SC$
$LAT = EAT + \frac{HC}{CFM \times 1.08}$	$LAT (DB) = EAT (DB) - \frac{SC}{CFM \times 1.08} \quad S/T = \frac{SC}{TC}$

1. Constant = 500 for water, 485 for antifreeze

Conversion Table - to convert inch-pound (English) to S-I (Metric)

Airflow	Water Flow	External Static Pressure	Water Pressure Drop
Airflow (L/s) = CFM x 0.472	Water Flow (L/s) = GPM x 0.0631	ESP (Pa) = ESP (in of wg) x 249	PD (kPa) = PD (ft of hd) x 2.99

Legend and Glossary of Abbreviations

Abbreviations	Descriptions
Btuh	Btu (British Thermal Unit) per hour
BMS	Building Management System
CDT	Compressor discharge temperature, °F
CFM	Airflow, cubic feet per minute
COP	Coefficient of performance = Btuh output/Btuh input
CT EC	Electronically commutated constant torque blower motor
CV EC	Electronically commutated constant volume blower motor
DB	Dry bulb temperature, °F
DT or Delta T	Temperature Differential
EAT	Entering air temperature, °F
EER	Energy efficient ratio = Btuh output/Watt input
ESP	External static pressure, inches w.g.
EWT	Entering water temperature, °F
FPT	Female pipe thread
GPM	Water flow in U.S., gallons per minute
HC	Air heating capacity, Btuh
HE	Total heat of extraction, Btuh
HGRH	Hot Gas Reheat
HR	Total heat of rejection, Btuh

Abbreviations	Descriptions
HWG	Hot water generator (desuperheater) capacity, MBtuh
kW	Total power unit input, kilowatts
LAT	Leaving air temperature, °F
LC	Latent cooling capacity, Btuh
LOC	Loss of charge
LWT	Leaving water temperature, °F
LLWT	Load Leaving Water Temperature, °F
MBtuh	1,000 Btu per hour
MPT	Male pipe thread
MWV	Motorized water valve
PSC	Permanent split capacitor
RDS	Refrigerant Detection System
SC	Sensible cooling capacity, Btuh
SLWT	Source Leaving Water Temperature, °F
S/T	Sensible to total cooling ratio
TC	Total cooling capacity, Btuh
VFD	Variable frequency drive
WB	Wet bulb temperature, °F
WPD	Waterside pressure drop, psi or feet of head
WSE	Waterside economizer

USE THE FOLLOWING SELECTION STEPS

1. Determine the actual heating and cooling loads at the desired dry bulb and wet bulb conditions.
2. Obtain the following design parameters: Entering water temperature, water flow rate in GPM, airflow in CFM, water flow pressure drop and design wet and dry bulb temperatures. Airflow CFM should be between 300 and 450 CFM per ton. Unit water pressure drop should be kept as close as possible to each other to make water balancing easier. Go to the appropriate tables and find the proper indicated water flow and water temperature.
3. Select a unit based on total and sensible cooling conditions. Select a unit which is closest to, but no larger than, the actual cooling load.
4. Enter tables at the design water flow and water temperature. Read the total and sensible cooling capacities (Note: interpolation is permissible, extrapolation is not).
5. Read the heating capacity. If it exceeds the design criteria it is acceptable. It is quite normal for water-source heat pumps to be selected on cooling capacity only since the heating output is usually greater than the cooling capacity.
6. Determine the correction factors associated with the variable factors of dry bulb and wet bulb.

Corrected Total Cooling =
tabulated total cooling x wet bulb correction.

Corrected Sensible Cooling =
tabulated sensible cooling x wet/dry bulb correction.
7. Determine the correction factor associated with antifreeze in system loop. If heating EWT is 50°F (10°C) or below you may have to use antifreeze. Calculate leaving water temperature per performance data selection notes. If antifreeze is required, use correction table for correcting total and sensible capacities.
8. Compare the corrected capacities to the load requirements. Normally if the capacities are within 10% of the loads, the equipment is acceptable. It is better to undersize than oversize, as undersizing improves humidity control, reduces sound levels and extends the life of the equipment.
9. When completed, calculate water temperature rise and assess the selection. If the units selected are not within 10% of the load calculations, then review what effect changing the GPM, water temperature and/or air flow and air temperature would have on the corrected capacities. If the desired capacity cannot be achieved, select the next larger or smaller unit and repeat the procedure. Remember, when in doubt, undersize slightly for best performance.

EXAMPLE EQUIPMENT SELECTION FOR COOLING

Step 1: Load Determination

Assume we have determined that the appropriate cooling load at the desired dry bulb 80°F and wet bulb 65°F conditions is as follows:

Total Cooling..... 90,500 Btuh
Sensible Cooling.....73,300 Btuh
Entering Air Temp.....80°F Dry Bulb / 65°F Wet Bulb

Step 2: Design Conditions

Similarly, we have also obtained the following design parameters:

Entering Water Temp (cooling)..... 90°F (32.2°C)
Entering Water Temp (heating).....60°F (15.6°C)
Water Flow (Based upon 10°F rise in temp)..18 GPM
Airflow2,800 CFM

Steps 3, 4, and 5: HP Selection

After making our preliminary selection (MB096), we enter the tables at design water flow and water temperature and read Total Cooling, Sensible Cooling and Heat of Rejection capacities:

Total Cooling.....93,200 Btuh
 Sensible Cooling.....70,390 Btuh
 Heat of Rejection120,100 Btuh
 Airflow3,200 CFM

Steps 6, 7, and 8: Entering Airflow Corrections

Next, we determine our correction factors.

Airflow $2,800 \div 3,200 = 88\%$ Antifreeze - None

Corrected Values	Table	Ent Air	Airflow	Corrected
Corrected Total Cooling	= 93,200	x 0.977	x 0.976	= 88,871
Corrected Sensible Cooling	= 70,390	x 1.088	x 0.933	= 71,453
Corrected Heat of Rejection	= 120,100	x 0.998	x 0.976	= 116,983

Step 9: Water Temperature Rise Calculation and Assessment

$$\text{Rise} = \text{Heat of Rejection} \div (\text{GPM} \times 500)$$

$$\text{Actual Temperature Rise } 116,983 \div 9,000 = 13.0^\circ\text{F } (-10^\circ\text{C})$$

When we compare the Corrected Total Cooling and Corrected Sensible Cooling figures with our load requirements stated in Step 1, we discover that our selection is within $\pm 10\%$ of our sensible load requirement. Furthermore, we see that our Corrected Total Cooling figure is within 1,000 Btuh the actual indicated load.

Alternate Step 7:

If your EWT for heating is 40°F (4.4°C), then system requires antifreeze. If a solution of 15% Propylene Glycol is required, then:

Corrected Values	Table	Ent Air	Airflow	Corrected
Corrected Total Cooling	= 88,871	x 0.986	x 0.976	= 87,626
Corrected Sensible Cooling	= 71,453	x 0.986	x 0.933	= 70,452

Model Nomenclature

Models:
MB
072-300

1 | 2 | 3 | 4 | 5 | 6 | 7 | 8 | 9 | 10 | 11 | 12 | 13 | 14 | 15
M | **B** | **L** | **0** | **7** | **2** | **B** | **K** | **C** | **3** | **0** | **C** | **0** | **1** | **S**

PRODUCT NAME

M = R-454B Refrigerant

MODEL TYPE

B = Compact High-Capacity Series

SUPPLY/RETURN CONFIGURATION

Horizontal		
Supply	Return	
	Left	Right
Straight	L	R
Back	B	P

Vertical	
Return/Supply	Option
Front/Top	F
Back/Top	C
Back/Front	G
Front/Back	H

SIZE

072	168 ¹
096	192 ¹
120	240 ¹
	300 ¹

REVISION

B = Current

VOLTAGE

3 Phase 60 Hz	With RDS
208/230	K
460	L
575	M

CONTROLS

Control	Standard	MPC
CXM2	C	N
CXM2 with Disconnect ³	W	R

Notes:

1. Only available on Vertical configurations
2. 575V option not available for configurations with VFD
3. Disconnect control option not available on configurations with Dual-Point Power
4. Horizontal units come standard with filter rails; filter frames are field-installed accessories
Vertical units come standard with filter frames
5. Waterside Economizer is only available for configurations with Extended Range cabinet
Waterside Economizer is not available on Vertical Back-supply configurations
6. A VFD is required when the large motor option is specified on unit size 240

STANDARD

S = Standard

BLOWER MOTOR

	Belt Drive	Single-Point Power	Dual-Point Power
	Standard Motor	Standard RPM	1
Low RPM		2	B
High RPM		3	C
Large Motor	Standard RPM	4	D
	High RPM	5	E
	VFD ⁶	6	F

EXTENDED OPTIONS⁵

0 = Standard, None
W = Waterside Economizer

DRAIN PAN/HEAT EXCHANGER OPTIONS

C = Standard Drain Pan, Noncoated Air Coil
S = Stainless-Steel Drain Pan, Noncoated Air Coil
E = Standard Drain Pan, E-Coated Air Coil
M = Stainless-Steel Drain Pan, E-Coated Air Coil

WATER OPTIONS

Horizontal				
Option	Coax			
	Copper		Cupronickel	
Water Side	Left	Right	Left	Right
None	0		1	
Vertical				
Option	Coax			
	Copper		Cupronickel	
Water Side	Left	Right	Left	Right
None	0	Z	1	2
MWV	M	V	3	4
MOD/MWV	C	N	5	6

CABINET OPTIONS

Cabinet	Sound Attenuation Package	Rail / Frame ⁴		
		1"	2"	4"
Extended Range	No	1	J	Q
	Yes	2	L	T
Standard Range	No	3	N	U
	Yes	4	F	V

Performance Data AHRI/ASHRAE/ISO 13256-1

Models:
MB
072-300

Tested in Accordance with AHRI/ASHRAE/ISO 13256-1 English (I-P) Units

Config	Size	Part/Full Load	Motor Type	Rated CFM	Rated GPM	Sheave Setting (turns open)	Water Loop - Current				Ground Water - Current				Ground Loop - Current			
							Cooling 86°F		Heating 68°F		Cooling 59°F		Heating 50°F		Cooling 77°F		Heating 32°F	
							Capacity Btuh	EER Btuh/W	Capacity Btuh	COP	Capacity Btuh	EER Btuh/W	Capacity Btuh	COP	Capacity Btuh	EER Btuh/W	Capacity Btuh	COP
H/V	72	F	Belt Drive	2,400	18	2.5	71,000	14.1	92,300	5.3	77,800	20.5	76,000	4.6	74,100	15.5	58,300	3.8
	96	F	Belt Drive	3,200	24	3	101,000	15.3	122,800	5.0	110,500	22.3	99,500	4.4	101,700	16.3	76,600	3.6
	120	F	Belt Drive	4,000	30	3	122,000	13.7	156,000	4.6	128,000	18.1	127,000	4.0	124,500	14.3	98,500	3.4
V	168	F	Belt Drive	5,600	42	3	168,000	14.4	192,000	4.7	186,000	21.0	151,800	4.1	172,000	16.2	121,000	3.5
	192	F	Belt Drive	6,400	48	3	187,000	14.9	220,000	5.1	201,000	21.5	181,000	4.5	194,000	16.5	139,000	3.7
	240	F	Belt Drive	8,000	60	2.5	232,000	13.9	294,000	4.9	256,000	20.0	236,000	4.3	232,000	14.3	179,000	3.5
H/V	72	F	Belt Drive with VFD	2,400	18	1	72,000	14.5	91,400	5.4	78,000	21.6	75,000	4.7	75,200	16.3	58,000	3.9
		P	Belt Drive with VFD	1,200	18	1	35,600	14.5	44,800	5.2	39,200	21.8	36,700	4.4	37,600	18.6	32,200	4.0
	96	F	Belt Drive with VFD	3,200	24	1	101,700	15.5	123,000	5.1	110,800	23.0	100,000	4.4	102,000	16.5	76,800	3.6
P		Belt Drive with VFD	1,600	24	1	50,300	16.3	61,200	5.1	54,900	24.2	49,800	4.3	52,400	20.4	43,200	3.9	
120	F	Belt Drive with VFD	4,000	30	1	124,000	13.9	156,000	4.7	128,500	18.6	127,000	4.1	125,000	14.8	98,500	3.5	
	P	Belt Drive with VFD	2,000	30	1	61,000	14.8	74,800	4.7	64,500	20.0	61,200	4.1	63,500	18.0	53,000	3.8	
V	168	F	Belt Drive with VFD	5,600	42	1	169,000	15.3	198,000	4.9	186,000	21.4	152,000	4.1	174,000	17.0	121,000	3.5
		P	Belt Drive with VFD	2,800	21	1	82,000	15.5	93,000	4.8	93,000	23.5	75,000	4.2	89,000	21.0	68,000	3.9
	192	F	Belt Drive with VFD	6,400	48	1	188,000	15.2	222,000	5.2	202,000	22.0	182,000	4.5	194,000	17.0	140,000	3.7
		P	Belt Drive with VFD	3,200	24	1	93,000	16.0	110,000	5.2	100,000	24.0	89,000	4.5	99,000	21.0	76,000	4.0
	240	F	Belt Drive with VFD	8,000	60	1	232,000	14.0	298,000	4.9	257,000	21.0	239,000	4.3	235,000	15.0	179,000	3.5
		P	Belt Drive with VFD	4,000	30	1	115,000	15.5	142,000	5.1	128,000	22.0	114,000	4.4	122,000	20.5	97,000	4.0
	300	F	Belt Drive with VFD	10,000	75	1	300,000	13.3	378,000	4.6	330,000	19.1	294,000	3.9	302,000	14.3	221,000	3.1
		P	Belt Drive with VFD	5,000	37.5	1	149,000	14.5	183,000	4.8	168,000	23.0	147,000	4.2	155,000	18.5	129,000	3.7

Notes:

- Where dual voltages are available, ratings are based on the lower voltage setting.
- Cooling capacities based upon 80.6°F DB, 66.2°F WB entering air temperature.
- Heating capacities based upon 68°F DB, 59°F WB entering air temperature.
- Ground Loop Heat Pump ratings based on 15% antifreeze solution.

Performance Data AHRI/ASHRAE/ISO 13256-1

Models:
MB
072-300

Tested in Accordance with AHRI/ASHRAE/ISO 13256-1 Metric (S-I) Units

Config	Size	Part/ Full Load	Motor Type	Rated Airflow (L/s)	Rated Water Flow (L/s)	Sheave Setting (turns open)	Water Loop - Current				Ground Water - Current				Ground Loop - Current			
							Cooling 30 °C		Heating 20 °C		Cooling 15 °C		Heating 10 °C		Cooling 25 °C		Heating 0 °C	
							Capacity Watts	EER W/W	Capacity Watts	COP	Capacity Watts	EER W/W	Capacity Watts	COP	Capacity Watts	EER W/W	Capacity Watts	COP
H/V	72	F	Belt Drive	1,133	1.14	2.5	20,809	4.1	27,052	5.3	22,802	6.0	22,274	4.6	21,717	4.5	17,087	3.8
	96	F	Belt Drive	1,510	1.51	3	29,601	4.5	35,991	5.0	32,386	6.5	29,162	4.4	29,807	4.8	22,450	3.6
	120	F	Belt Drive	1,888	1.89	3	35,756	4.0	45,721	4.6	37,515	5.3	37,222	4.0	36,489	4.2	28,869	3.4
V	168	F	Belt Drive	2,643	2.65	3	49,238	4.2	56,272	4.7	54,513	6.2	44,490	4.1	50,410	4.7	35,463	3.5
	192	F	Belt Drive	3,020	3.03	3	54,807	4.4	64,478	5.1	58,910	6.3	53,048	4.5	56,858	4.8	40,739	3.7
	240	F	Belt Drive	3,776	3.79	2.5	67,995	4.1	86,166	4.9	75,029	5.9	69,168	4.3	67,995	4.2	52,462	3.5
H/V	72	F	Belt Drive with VFD	1,133	1.14	1	21,102	4.2	26,788	5.4	22,860	6.3	21,981	4.7	22,040	4.8	16,999	3.9
		P	Belt Drive with VFD	566	1.14	1	10,434	4.2	13,130	5.2	11,489	6.4	10,756	4.4	11,020	5.5	9,437	4.0
	96	F	Belt Drive with VFD	1,510	1.51	1	29,807	4.5	36,049	5.1	32,474	6.7	29,308	4.4	29,894	4.8	22,509	3.6
		P	Belt Drive with VFD	755	1.51	1	14,742	4.8	17,937	5.1	16,090	7.1	14,596	4.3	15,358	6.0	12,661	3.9
	120	F	Belt Drive with VFD	1,888	1.89	1	36,342	4.1	45,721	4.7	37,661	5.5	37,222	4.1	36,635	4.3	28,869	3.5
		P	Belt Drive with VFD	944	1.89	1	17,878	4.3	21,923	4.7	18,904	5.9	17,937	4.1	18,611	5.3	15,533	3.8
V	168	F	Belt Drive with VFD	2,643	2.65	1	49,531	4.5	58,030	4.9	54,513	6.3	44,549	4.1	50,996	5.0	35,463	3.5
		P	Belt Drive with VFD	1,321	1.32	1	24,033	4.5	27,257	4.8	27,257	6.9	21,981	4.2	26,084	6.2	19,930	3.9
	192	F	Belt Drive with VFD	3,020	3.03	1	55,100	4.5	65,064	5.2	59,203	6.4	53,341	4.5	56,858	5.0	41,032	3.7
		P	Belt Drive with VFD	1,510	1.51	1	27,257	4.7	32,239	5.2	29,308	7.0	26,084	4.5	29,015	6.2	22,274	4.0
	240	F	Belt Drive with VFD	3,776	3.79	1	67,995	4.1	87,339	4.9	75,322	6.2	70,047	4.3	68,875	4.4	52,462	3.5
		P	Belt Drive with VFD	1,888	1.89	1	33,705	4.5	41,618	5.1	37,515	6.4	33,411	4.4	35,756	6.0	28,429	4.0
	300	F	Belt Drive with VFD	4,719	4.73	1	87,925	3.9	110,785	4.6	96,717	5.6	86,166	3.9	88,511	4.2	64,771	3.1
		P	Belt Drive with VFD	2,360	2.37	1	43,669	4.2	53,634	4.8	49,238	6.7	43,083	4.2	45,428	5.4	37,808	3.7

- Notes:
- Where dual voltages are available, ratings are based on the lower voltage setting.
 - Cooling capacities based upon 27°C DB, 19°C WB entering air temperature.
 - Heating capacities based upon 20°C DB, 15°C WB entering air temperature.
 - Ground Loop Heat Pump ratings based on 15% antifreeze solution.

Performance Data Selection Notes

Models:
MB
072-300

MB096

EWT °F	WATER/BRINE			Heating - EAT 70°F				
	FLOW GPM	PD psi	PD ft.	HC	kW	HE	LAT	COP
50	12.0	1.7	4.0	96.7	7.17	72.2	95.9	4.0
	18.0	4.5	10.3	101.9	7.27	77.1	97.4	4.1
	24.0	7.9	18.2	104.7	7.32	79.8	98.2	4.2

For operation in the shaded area when water is used in lieu of an antifreeze solution, the LWT (Leaving Water Temperature) must be calculated. Flow must be maintained to a level such that the LWT is maintained above 42°F (5.6°C) when the JW3 jumper is not clipped (see example below). Otherwise, appropriate levels of a proper antifreeze solution should be used in systems with leaving water temperatures of 42°F (5.6°C) or below and the JW3

jumper should be clipped. This is due to the potential of the refrigerant temperature being as low as 32°F (0°C) with 40°F (4.4°C) LWT, which may lead to a nuisance cutout due to the activation of the Low Temperature Protection. JW3 should never be clipped for standard range equipment or systems without antifreeze.

Example:

At 50°F EWT (Entering Water Temperature) and 1.5 GPM/ton, a 8 ton unit has a HE of 72,200 Btuh.

To calculate LWT, rearrange the formula for HE as follows:

HE = TD x GPM x 500, where HE = Heat of Extraction (Btuh);

TD = temperature difference (EWT - LWT) and GPM = U.S. Gallons per Minute.

$$TD = HE / (GPM \times 500)$$

$$TD = 72,200 / (1.5 \times 500)$$

$$TD = 12^\circ\text{F}$$

$$\text{LWT} = \text{EWT} - \text{TD}$$

$$\text{LWT} = 50 - 12 = 38^\circ\text{F} - \text{antifreeze must be used}$$

In this example, a higher flow rate will be required for EWTs at or below 50°F without antifreeze.

Performance Data MB072 Full Load

Models:
MB
072-300

2,400 CFM Rated Airflow

EWT °F	WPD			Cooling - EAT 80/67°F									Heating - EAT 70°F									
	FLOW GPM	PSI	FT	TC	SC	3-Phase Std Motor			VFD			3-Phase Std Motor				VFD						
						Power kW	HR	EER	Power kW	HR	EER	HC	Power kW	HE	LAT	COP	HC	Power kW	HE	LAT	COP	
20	18.00	6.1	14.0	Operation Not Recommended									48.9	4.8	32.6	86.8	3.0	48.6	4.71	32.6	86.7	3.0
30	9.00	1.7	3.9	79.0	55.2	3.40	90.6	23.2	3.32	90.3	23.8	54.0	4.9	37.3	88.8	3.2	53.7	4.79	37.3	88.7	3.3	
	13.50	3.3	7.7	79.1	55.6	3.22	90.1	24.5	3.13	89.8	25.2	56.3	4.9	39.5	89.7	3.4	56.0	4.83	39.5	89.5	3.4	
	18.00	5.1	11.7	79.0	55.8	3.14	89.7	25.1	3.06	89.4	25.8	57.5	4.9	40.7	90.1	3.4	57.2	4.85	40.7	90.0	3.5	
40	9.00	1.4	3.2	78.2	54.4	3.72	91.0	21.0	3.64	90.7	21.5	61.8	5.0	44.8	91.8	3.6	61.6	4.91	44.8	91.7	3.7	
	13.50	2.8	6.3	78.8	54.9	3.50	90.8	22.5	3.42	90.5	23.1	64.6	5.0	47.4	92.9	3.8	64.3	4.96	47.4	92.8	3.8	
	18.00	4.4	10.1	79.0	55.2	3.40	90.6	23.2	3.31	90.3	23.8	66.1	5.1	48.8	93.4	3.8	65.8	4.98	48.8	93.3	3.9	
50	9.00	1.2	2.7	76.9	53.5	4.11	90.9	18.7	4.02	90.6	19.1	69.7	5.1	52.2	94.8	4.0	69.4	5.04	52.2	94.7	4.0	
	13.50	2.4	5.5	77.9	54.1	3.84	91.0	20.3	3.76	90.7	20.7	72.9	5.2	55.2	96.0	4.1	72.6	5.08	55.2	95.9	4.2	
	18.00	3.9	9.0	78.3	54.4	3.72	90.9	21.0	3.63	90.7	21.5	74.6	5.2	56.9	96.7	4.2	74.3	5.11	56.9	96.6	4.3	
60	9.00	1.0	2.4	74.9	52.5	4.54	90.4	16.5	4.46	90.1	16.8	77.4	5.2	59.6	97.8	4.3	77.1	5.15	59.6	97.7	4.4	
	13.50	2.1	4.9	76.3	53.2	4.24	90.8	18.0	4.16	90.5	18.4	81.0	5.3	63.0	99.2	4.5	80.7	5.21	63.0	99.1	4.5	
	18.00	3.6	8.3	76.9	53.5	4.10	90.9	18.7	4.02	90.6	19.1	82.9	5.3	64.8	99.9	4.6	82.7	5.23	64.8	99.8	4.6	
70	9.00	1.0	2.3	72.5	51.4	5.04	89.7	14.4	4.95	89.4	14.6	85.1	5.4	66.8	100.7	4.7	84.8	5.26	66.8	100.6	4.7	
	13.50	2.0	4.7	74.2	52.1	4.70	90.2	15.8	4.62	89.9	16.1	89.0	5.4	70.6	102.3	4.8	88.7	5.32	70.6	102.2	4.9	
	18.00	3.4	7.8	74.9	52.5	4.54	90.4	16.5	4.46	90.1	16.8	91.2	5.4	72.6	103.1	4.9	90.9	5.35	72.6	103.0	5.0	
80	9.00	1.0	2.2	69.7	50.3	5.59	88.7	12.5	5.50	88.4	12.7	92.6	5.5	74.0	103.6	5.0	92.3	5.37	74.0	103.5	5.0	
	13.50	2.0	4.6	71.6	51.0	5.22	89.4	13.7	5.13	89.1	14.0	96.9	5.5	78.1	105.3	5.2	96.6	5.42	78.1	105.2	5.2	
	18.00	3.3	7.6	72.5	51.4	5.04	89.7	14.4	4.95	89.4	14.6	99.2	5.5	80.2	106.2	5.2	98.9	5.45	80.2	106.1	5.3	
90	9.00	0.9	2.2	66.5	49.0	6.19	87.6	10.7	6.10	87.3	10.9	99.9	5.6	81.0	106.5	5.3	99.6	5.46	81.0	106.4	5.3	
	13.50	2.0	4.5	68.6	49.8	5.79	88.3	11.8	5.70	88.0	12.0	104.5	5.6	85.4	108.2	5.5	104.2	5.52	85.4	108.1	5.5	
	18.00	3.2	7.5	69.6	50.2	5.60	88.7	12.4	5.51	88.4	12.6	106.9	5.6	87.7	109.2	5.6	106.6	5.55	87.7	109.0	5.6	
100	9.00	0.9	2.1	63.0	47.6	6.85	86.4	9.2	6.76	86.1	9.3	Operation Not Recommended										
	13.50	1.9	4.4	65.3	48.5	6.42	87.2	10.2	6.33	86.9	10.3											
	18.00	3.2	7.3	66.4	49.0	6.21	87.5	10.7	6.12	87.3	10.8											
110	9.00	0.9	2.0	59.3	46.1	7.56	85.1	7.8	7.47	84.8	7.9											
	13.50	1.8	4.2	61.7	47.1	7.10	85.9	8.7	7.01	85.6	8.8											
	18.00	3.1	7.1	62.8	47.6	6.88	86.3	9.1	6.79	86.0	9.3											
120	9.00	0.7	1.7	55.4	44.5	8.32	83.8	6.7	8.23	83.5	6.7											
	13.50	1.6	3.8	57.9	45.5	7.84	84.6	7.4	7.75	84.3	7.5											
	18.00	2.9	6.7	59.1	46.0	7.60	85.0	7.8	7.51	84.7	7.9											

Notes:

- Interpolation is permissible, extrapolation is not.
- All entering air conditions are 80°F (26.6°C) DB and 67°F (19.4°C) WB in cooling, and 70°F (21°C) DB in heating.
- AHRI/ISO certified conditions are 80.6°F (27°C) DB and 66.2°F (19°C) WB in cooling and 68°F (20°C) DB in heating.
- Table does not reflect fan or pump power corrections for AHRI/ISO conditions.
- All performance data is based on the lower voltage of dual voltage units.
- Performance stated is at the rated power supply; performance may vary as the power supply varies from the rated.
- Operation below 40°F EWT is based on a 15% methanol antifreeze solution.
- Operation below 60°F EWT requires optional insulated water/refrigerant circuit.
- See performance correction tables for operating conditions other than those listed above.
- See Performance Data Selection Notes for operation in the shaded areas.

Performance Data MB072 Part Load (VFD)

Models:
MB
072-300

1,200 CFM Rated Airflow

EWT °F	WPD			Cooling - EAT 80/67°F					Heating - EAT 70°F				
	FLOW GPM	PSI	FT	TC	SC	VFD			VFD				
						Power kW	HR	EER	HC	Power kW	HE	LAT	COP
20	18.00	6.0	13.9	Operation Not Recommended					23.1	2.19	15.6	85.8	3.1
30	9.00	1.7	3.8	40.8	28.6	1.37	45.5	29.8	26.6	2.24	18.9	88.5	3.5
	13.50	3.3	7.6	41.1	28.8	1.32	45.6	31.2	27.2	2.25	19.5	88.9	3.5
	18.00	5.1	11.7	41.2	28.9	1.29	45.7	31.9	27.5	2.26	19.8	89.2	3.6
40	9.00	1.4	3.2	40.0	27.9	1.53	45.2	26.1	30.8	2.30	22.9	91.7	3.9
	13.50	2.7	6.3	40.2	28.1	1.47	45.3	27.3	31.5	2.32	23.6	92.3	4.0
	18.00	4.4	10.2	40.4	28.2	1.45	45.3	27.9	31.9	2.32	24.0	92.6	4.0
50	9.00	1.2	2.7	39.1	27.4	1.72	45.0	22.8	34.9	2.37	26.9	94.9	4.3
	13.50	2.4	5.5	39.4	27.6	1.65	45.0	23.9	35.8	2.38	27.7	95.5	4.4
	18.00	3.9	9.1	39.5	27.6	1.62	45.1	24.4	36.2	2.39	28.1	95.9	4.4
60	9.00	1.1	2.4	38.2	27.0	1.93	44.8	19.8	39.1	2.43	30.8	98.1	4.7
	13.50	2.1	5.0	38.5	27.1	1.86	44.9	20.8	40.0	2.44	31.7	98.8	4.8
	18.00	3.6	8.3	38.7	27.2	1.82	44.9	21.3	40.5	2.45	32.2	99.2	4.8
70	9.00	1.0	2.3	37.2	26.6	2.17	44.6	17.1	43.2	2.49	34.7	101.3	5.1
	13.50	2.0	4.7	37.5	26.7	2.09	44.7	18.0	44.3	2.51	35.8	102.1	5.2
	18.00	3.4	7.9	37.7	26.8	2.05	44.7	18.4	44.9	2.51	36.3	102.6	5.2
80	9.00	1.0	2.2	35.9	26.2	2.44	44.3	14.7	47.5	2.55	38.8	104.5	5.5
	13.50	2.0	4.6	36.4	26.3	2.35	44.4	15.5	48.7	2.57	40.0	105.5	5.6
	18.00	3.3	7.6	36.6	26.4	2.30	44.4	15.9	49.4	2.58	40.6	106.0	5.6
90	9.00	0.9	2.2	34.4	25.8	2.74	43.8	12.6	51.8	2.61	42.9	107.9	5.8
	13.50	2.0	4.5	35.0	26.0	2.64	44.0	13.2	53.2	2.63	44.3	109.0	5.9
	18.00	3.2	7.5	35.2	26.0	2.59	44.1	13.6	54.0	2.64	45.0	109.6	6.0
100	9.00	0.9	2.1	32.6	25.3	3.08	43.1	10.6	Operation Not Recommended				
	13.50	1.9	4.4	33.2	25.5	2.97	43.4	11.2					
	18.00	3.2	7.4	33.5	25.6	2.91	43.5	11.5					
110	9.00	0.9	2.0	30.4	24.6	3.45	42.2	8.8					
	13.50	1.8	4.2	31.1	24.9	3.33	42.5	9.4					
	18.00	3.1	7.2	31.5	25.0	3.27	42.7	9.6					
120	9.00	0.8	1.8	27.8	23.6	3.85	40.9	7.2					
	13.50	1.7	3.9	28.6	24.0	3.72	41.3	7.7					
	18.00	2.9	6.8	29.0	24.1	3.66	41.5	7.9					

Notes:

- Interpolation is permissible, extrapolation is not.
- All entering air conditions are 80°F (26.6°C) DB and 67°F (19.4°C) WB in cooling, and 70°F (21°C) DB in heating.
- AHRI/ISO certified conditions are 80.6°F (27°C) DB and 66.2°F (19°C) WB in cooling and 68°F (20°C) DB in heating.
- Table does not reflect fan or pump power corrections for AHRI/ISO conditions.
- All performance data is based on the lower voltage of dual voltage units.
- Performance stated is at the rated power supply; performance may vary as the power supply varies from the rated.
- Operation below 40°F EWT is based on a 15% methanol antifreeze solution.
- Operation below 60°F EWT requires optional insulated water/refrigerant circuit.
- See performance correction tables for operating conditions other than those listed above.
- See Performance Data Selection Notes for operation in the shaded areas.

Performance Data MB096 Full Load

Models:
MB
072-300

3,200 CFM Rated Airflow

EWT °F	WPD			Cooling - EAT 80/67°F									Heating - EAT 70°F									
	FLOW GPM	PSI	FT	TC	SC	3-Phase Std Motor			VFD			3-Phase Std Motor				VFD						
						Power kW	HR	EER	Power kW	HR	EER	HC	Power kW	HE	LAT	COP	HC	Power kW	HE	LAT	COP	
20	24.00	9.1	20.9	Operation Not Recommended									64.6	6.6	42.2	86.7	2.9	64.5	6.52	42.2	86.6	2.9
30	12.00	2.6	5.9	107.1	74.0	4.52	122.6	23.7	4.47	122.4	24.0	71.5	6.7	48.8	88.6	3.2	71.3	6.60	48.8	88.6	3.2	
	18.00	5.4	12.5	105.0	72.6	4.33	119.8	24.2	4.28	119.7	24.5	74.7	6.7	51.9	89.6	3.3	74.5	6.64	51.9	89.5	3.3	
	24.00	8.3	19.2	103.7	71.7	4.26	118.2	24.3	4.21	118.0	24.6	76.5	6.7	53.6	90.1	3.3	76.3	6.66	53.6	90.0	3.4	
40	12.00	2.3	5.3	108.5	75.0	4.89	125.1	22.2	4.84	125.0	22.4	82.9	6.8	59.7	91.9	3.6	82.8	6.75	59.7	91.9	3.6	
	18.00	5.0	11.5	107.8	74.4	4.63	123.5	23.3	4.58	123.4	23.6	87.2	6.9	63.8	93.2	3.7	87.0	6.81	63.8	93.1	3.7	
	24.00	7.7	17.7	107.1	73.9	4.52	122.5	23.7	4.46	122.3	24.0	89.6	6.9	66.0	93.9	3.8	89.4	6.84	66.0	93.8	3.8	
50	12.00	2.1	4.8	108.0	75.0	5.34	126.3	20.2	5.29	126.1	20.4	95.1	7.0	71.3	95.4	4.0	94.9	6.92	71.3	95.4	4.0	
	18.00	4.6	10.6	108.5	75.1	5.02	125.6	21.6	4.97	125.4	21.8	100.3	7.0	76.3	97.0	4.2	100.1	6.99	76.3	96.9	4.2	
	24.00	7.1	16.5	108.4	75.0	4.87	125.1	22.3	4.82	124.9	22.5	103.3	7.1	79.1	97.8	4.3	103.1	7.03	79.1	97.8	4.3	
60	12.00	1.9	4.5	106.2	74.2	5.89	126.3	18.0	5.84	126.1	18.2	107.5	7.1	83.1	99.0	4.4	107.4	7.09	83.1	99.0	4.4	
	18.00	4.3	10.0	107.6	74.9	5.50	126.4	19.6	5.45	126.2	19.8	113.7	7.2	89.0	100.8	4.6	113.5	7.19	89.0	100.8	4.6	
	24.00	6.7	15.5	108.1	75.0	5.32	126.2	20.3	5.27	126.0	20.5	117.1	7.3	92.3	101.8	4.7	117.0	7.24	92.3	101.8	4.7	
70	12.00	1.9	4.3	103.3	72.9	6.51	125.6	15.9	6.46	125.4	16.0	120.0	7.3	95.0	102.6	4.8	119.8	7.28	95.0	102.6	4.8	
	18.00	4.1	9.5	105.4	73.9	6.07	126.1	17.4	6.02	126.0	17.5	127.0	7.4	101.6	104.7	5.0	126.8	7.39	101.6	104.6	5.0	
	24.00	6.4	14.7	106.3	74.3	5.86	126.3	18.2	5.81	126.1	18.3	130.8	7.5	105.2	105.7	5.1	130.6	7.45	105.2	105.7	5.1	
80	12.00	1.8	4.1	99.7	71.1	7.21	124.3	13.8	7.16	124.1	13.9	132.2	7.5	106.6	106.2	5.2	132.1	7.47	106.6	106.1	5.2	
	18.00	3.9	9.1	102.3	72.4	6.72	125.2	15.2	6.67	125.0	15.3	139.7	7.6	113.6	108.3	5.4	139.5	7.59	113.6	108.3	5.4	
	24.00	6.1	14.0	103.5	73.0	6.48	125.6	16.0	6.43	125.4	16.1	143.6	7.7	117.3	109.5	5.5	143.4	7.65	117.3	109.4	5.5	
90	12.00	1.8	4.1	95.6	68.9	7.99	122.8	12.0	7.94	122.7	12.0	143.9	7.7	117.6	109.5	5.5	143.7	7.66	117.6	109.5	5.5	
	18.00	3.8	8.8	98.5	70.4	7.45	123.9	13.2	7.40	123.7	13.3	151.4	7.8	124.6	111.7	5.7	151.2	7.79	124.6	111.6	5.7	
	24.00	5.9	13.6	99.8	71.1	7.19	124.4	13.9	7.14	124.2	14.0	155.2	7.9	128.2	112.8	5.8	155.0	7.85	128.2	112.8	5.8	
100	12.00	1.7	4.0	91.1	66.7	8.85	121.3	10.3	8.80	121.1	10.4	Operation Not Recommended										
	18.00	3.7	8.6	94.2	68.2	8.26	122.3	11.4	8.21	122.2	11.5											
	24.00	5.7	13.2	95.7	69.0	7.97	122.9	12.0	7.92	122.7	12.1											
110	12.00	1.7	3.9	86.7	64.4	9.78	120.0	8.9	9.73	119.9	8.9											
	18.00	3.7	8.4	89.6	65.9	9.15	120.9	9.8	9.10	120.7	9.9											
	24.00	5.6	13.0	91.2	66.7	8.84	121.3	10.3	8.79	121.2	10.4											
120	12.00	1.6	3.7	82.4	62.2	10.80	119.2	7.6	10.75	119.0	7.7											
	18.00	3.6	8.3	85.2	63.6	10.12	119.7	8.4	10.06	119.5	8.5											
	24.00	5.6	12.9	86.6	64.4	9.79	120.0	8.9	9.73	119.9	8.9											

Notes:

- Interpolation is permissible, extrapolation is not.
- All entering air conditions are 80°F (26.6°C) DB and 67°F (19.4°C) WB in cooling, and 70°F (21°C) DB in heating.
- AHRI/ISO certified conditions are 80.6°F (27°C) DB and 66.2°F (19°C) WB in cooling and 68°F (20°C) DB in heating.
- Table does not reflect fan or pump power corrections for AHRI/ISO conditions.
- All performance data is based on the lower voltage of dual voltage units.
- Performance stated is at the rated power supply; performance may vary as the power supply varies from the rated.
- Operation below 40°F EWT is based on a 15% methanol antifreeze solution.
- Operation below 60°F EWT requires optional insulated water/refrigerant circuit.
- See performance correction tables for operating conditions other than those listed above.
- See Performance Data Selection Notes for operation in the shaded areas.

Performance Data MB096 Part Load (VFD)

Models:
MB
072-300

1,600 CFM Rated Airflow

EWT °F	WPD			Cooling - EAT 80/67°F					Heating - EAT 70°F				
	FLOW GPM	PSI	FT	TC	SC	VFD			VFD				
						Power kW	HR	EER	HC	Power kW	HE	LAT	COP
20	24.00	8.3	19.2	Operation Not Recommended					31.0	2.95	21.0	85.9	3.1
30	12.00	2.2	5.2	55.5	38.8	1.77	61.5	31.4	35.7	3.03	25.3	88.6	3.4
	18.00	5.0	11.5	55.1	38.6	1.70	60.9	32.4	36.5	3.05	26.1	89.1	3.5
	24.00	7.7	17.8	54.9	38.4	1.67	60.6	32.9	36.9	3.05	26.5	89.3	3.5
40	12.00	2.1	4.8	56.1	39.2	1.99	62.9	28.3	41.5	3.13	30.9	92.0	3.9
	18.00	4.7	10.7	56.0	39.1	1.91	62.5	29.3	42.6	3.14	31.9	92.6	4.0
	24.00	7.2	16.7	55.9	39.1	1.87	62.3	29.9	43.2	3.15	32.4	92.9	4.0
50	12.00	2.0	4.5	56.0	39.0	2.23	63.6	25.1	47.6	3.22	36.6	95.5	4.3
	18.00	4.4	10.1	56.1	39.1	2.14	63.4	26.2	48.9	3.24	37.8	96.2	4.4
	24.00	6.8	15.8	56.1	39.1	2.10	63.3	26.8	49.6	3.25	38.5	96.6	4.5
60	12.00	1.9	4.3	55.2	38.4	2.49	63.7	22.1	53.8	3.32	42.4	99.0	4.7
	18.00	4.2	9.7	55.5	38.7	2.40	63.7	23.2	55.3	3.34	43.9	99.9	4.8
	24.00	6.5	15.0	55.7	38.8	2.35	63.7	23.7	56.1	3.35	44.6	100.4	4.9
70	12.00	1.8	4.2	53.9	37.6	2.80	63.4	19.3	59.9	3.42	48.3	102.6	5.1
	18.00	4.0	9.3	54.4	37.9	2.68	63.6	20.3	61.6	3.44	49.9	103.6	5.2
	24.00	6.3	14.4	54.6	38.1	2.63	63.6	20.8	62.5	3.46	50.7	104.1	5.3
80	12.00	1.8	4.1	52.1	36.6	3.14	62.8	16.6	66.0	3.51	54.0	106.1	5.5
	18.00	3.9	9.0	52.8	37.0	3.01	63.1	17.5	67.8	3.54	55.7	107.2	5.6
	24.00	6.0	14.0	53.1	37.2	2.95	63.2	18.0	68.8	3.56	56.6	107.7	5.7
90	12.00	1.7	4.0	50.0	35.5	3.52	62.0	14.2	71.9	3.62	59.5	109.5	5.8
	18.00	3.8	8.8	50.8	35.9	3.38	62.3	15.0	73.8	3.65	61.3	110.6	5.9
	24.00	5.9	13.6	51.1	36.1	3.32	62.5	15.4	74.8	3.67	62.3	111.2	6.0
100	12.00	1.7	4.0	47.6	34.4	3.96	61.1	12.0	Operation Not Recommended				
	18.00	3.7	8.6	48.5	34.8	3.81	61.4	12.7					
	24.00	5.8	13.3	48.9	34.9	3.73	61.6	13.1					
110	12.00	1.7	3.9	45.0	33.2	4.46	60.2	10.1					
	18.00	3.7	8.5	45.9	33.6	4.28	60.5	10.7					
	24.00	5.7	13.1	46.3	33.8	4.20	60.7	11.0					
120	12.00	1.6	3.7	42.3	32.2	5.01	59.4	8.4					
	18.00	3.6	8.3	43.2	32.5	4.82	59.6	9.0					
	24.00	5.6	12.9	43.6	32.7	4.73	59.8	9.2					

Notes:

- Interpolation is permissible, extrapolation is not.
- All entering air conditions are 80°F (26.6°C) DB and 67°F (19.4°C) WB in cooling, and 70°F (21°C) DB in heating.
- AHRI/ISO certified conditions are 80.6°F (27°C) DB and 66.2°F (19°C) WB in cooling and 68°F (20°C) DB in heating.
- Table does not reflect fan or pump power corrections for AHRI/ISO conditions.
- All performance data is based on the lower voltage of dual voltage units.
- Performance stated is at the rated power supply; performance may vary as the power supply varies from the rated.
- Operation below 40°F EWT is based on a 15% methanol antifreeze solution.
- Operation below 60°F EWT requires optional insulated water/refrigerant circuit.
- See performance correction tables for operating conditions other than those listed above.
- See Performance Data Selection Notes for operation in the shaded areas.

Performance Data MB120 Full Load

Models:
MB
072-300

4,000 CFM Rated Airflow

EWT °F	WPD			Cooling - EAT 80/67°F									Heating - EAT 70°F									
	FLOW GPM	PSI	FT	TC	SC	3-Phase Std Motor			VFD			3-Phase Std Motor				VFD						
						Power kW	HR	EER	Power kW	HR	EER	HC	Power kW	HE	LAT	COP	HC	Power kW	HE	LAT	COP	
20	30.00	9.7	22.4	Operation Not Recommended									86.5	8.9	56.0	88.0	2.8	86.4	8.91	56.0	87.9	2.8
30	15.00	2.8	6.5	118.9	81.2	6.66	141.6	17.8	6.63	141.5	17.9	93.0	9.1	62.1	89.5	3.0	92.9	9.04	62.1	89.5	3.0	
	22.50	5.9	13.6	113.8	76.9	6.33	135.4	18.0	6.30	135.3	18.1	96.4	9.1	65.2	90.3	3.1	96.3	9.11	65.2	90.2	3.1	
	30.00	9.0	20.8	110.9	74.6	6.18	132.0	17.9	6.15	131.9	18.0	98.3	9.2	67.0	90.7	3.1	98.2	9.15	67.0	90.7	3.1	
40	15.00	2.7	6.2	124.4	85.8	7.21	149.0	17.3	7.18	148.9	17.3	105.5	9.3	73.7	92.4	3.3	105.4	9.31	73.7	92.3	3.3	
	22.50	5.6	12.8	121.2	83.1	6.86	144.6	17.7	6.83	144.5	17.8	110.3	9.4	78.1	93.5	3.4	110.2	9.41	78.1	93.5	3.4	
	30.00	8.5	19.5	119.3	81.5	6.69	142.1	17.8	6.66	142.0	17.9	113.0	9.5	80.6	94.1	3.5	112.9	9.47	80.6	94.1	3.5	
50	15.00	2.6	6.0	127.0	88.0	7.79	153.6	16.3	7.77	153.5	16.3	119.8	9.7	86.8	95.7	3.6	119.7	9.62	86.8	95.6	3.6	
	22.50	5.3	12.3	125.5	86.8	7.40	150.8	17.0	7.37	150.7	17.0	125.9	9.8	92.5	97.1	3.8	125.8	9.76	92.5	97.1	3.8	
	30.00	8.0	18.5	124.4	85.8	7.22	149.0	17.2	7.19	148.9	17.3	129.4	9.9	95.7	97.9	3.8	129.3	9.84	95.7	97.9	3.8	
60	15.00	2.5	5.8	127.2	88.5	8.43	155.9	15.1	8.40	155.8	15.1	135.0	10.0	100.9	99.2	4.0	134.9	9.97	100.9	99.2	4.0	
	22.50	5.1	11.8	127.3	88.4	7.99	154.5	15.9	7.96	154.4	16.0	142.4	10.2	107.7	100.9	4.1	142.3	10.15	107.7	100.9	4.1	
	30.00	7.7	17.8	126.9	88.0	7.78	153.5	16.3	7.75	153.4	16.4	146.5	10.3	111.5	101.8	4.2	146.4	10.24	111.5	101.8	4.2	
70	15.00	2.5	5.7	125.4	87.6	9.15	156.7	13.7	9.12	156.6	13.8	150.5	10.4	115.1	102.8	4.3	150.4	10.33	115.1	102.7	4.3	
	22.50	5.0	11.5	126.8	88.3	8.64	156.3	14.7	8.61	156.2	14.7	158.9	10.6	122.8	104.7	4.4	158.8	10.53	122.8	104.7	4.4	
	30.00	7.5	17.2	127.2	88.5	8.41	155.9	15.1	8.38	155.8	15.2	163.4	10.7	127.0	105.7	4.5	163.3	10.64	127.0	105.7	4.5	
80	15.00	2.4	5.6	122.2	85.7	9.96	156.2	12.3	9.93	156.1	12.3	165.7	10.7	129.1	106.3	4.5	165.6	10.69	129.1	106.2	4.5	
	22.50	4.8	11.2	124.6	87.1	9.38	156.6	13.3	9.35	156.5	13.3	174.4	10.9	137.1	108.3	4.7	174.3	10.90	137.1	108.3	4.7	
	30.00	7.3	16.8	125.6	87.6	9.11	156.7	13.8	9.09	156.6	13.8	179.0	11.0	141.3	109.3	4.8	178.9	11.01	141.3	109.3	4.8	
90	15.00	2.4	5.5	117.7	83.2	10.88	154.8	10.8	10.85	154.7	10.9	179.8	11.1	142.0	109.5	4.8	179.7	11.03	142.0	109.5	4.8	
	22.50	4.7	10.9	120.9	85.0	10.23	155.8	11.8	10.20	155.7	11.9	188.2	11.3	149.8	111.5	4.9	188.1	11.23	149.8	111.4	4.9	
	30.00	7.1	16.4	122.4	85.8	9.92	156.2	12.3	9.89	156.1	12.4	192.3	11.4	153.6	112.4	5.0	192.2	11.33	153.6	112.4	5.0	
100	15.00	2.3	5.4	112.3	80.4	11.93	153.0	9.4	11.90	152.9	9.4	Operation Not Recommended										
	22.50	4.6	10.7	116.1	82.4	11.19	154.3	10.4	11.17	154.2	10.4											
	30.00	6.9	16.0	117.9	83.3	10.85	154.9	10.9	10.82	154.8	10.9											
110	15.00	2.3	5.2	106.2	77.4	13.14	151.0	8.1	13.11	150.9	8.1											
	22.50	4.5	10.4	110.4	79.4	12.30	152.4	9.0	12.28	152.3	9.0											
	30.00	6.7	15.5	112.4	80.4	11.91	153.1	9.4	11.88	153.0	9.5											
120	15.00	2.2	5.0	99.6	74.4	14.52	149.1	6.9	14.49	149.0	6.9											
	22.50	4.3	10.0	104.0	76.4	13.58	150.4	7.7	13.55	150.3	7.7											
	30.00	6.5	15.0	106.2	77.4	13.13	151.0	8.1	13.10	150.9	8.1											

Notes:

- Interpolation is permissible, extrapolation is not.
- All entering air conditions are 80°F (26.6°C) DB and 67°F (19.4°C) WB in cooling, and 70°F (21°C) DB in heating.
- AHRI/ISO certified conditions are 80.6°F (27°C) DB and 66.2°F (19°C) WB in cooling and 68°F (20°C) DB in heating.
- Table does not reflect fan or pump power corrections for AHRI/ISO conditions.
- All performance data is based on the lower voltage of dual voltage units.
- Performance stated is at the rated power supply; performance may vary as the power supply varies from the rated.
- Operation below 40°F EWT is based on a 15% methanol antifreeze solution.
- Operation below 60°F EWT requires optional insulated water/refrigerant circuit.
- See performance correction tables for operating conditions other than those listed above.
- See Performance Data Selection Notes for operation in the shaded areas.

Performance Data MB120 Part Load (VFD)

Models:
MB
072-300

2,000 CFM Rated Airflow

EWT °F	WPD			Cooling - EAT 80/67°F					Heating - EAT 70°F				
	FLOW GPM	PSI	FT	TC	SC	VFD			VFD				
						Power kW	HR	EER	HC	Power kW	HE	LAT	COP
20	30.00	9.8	22.6	Operation Not Recommended					39.7	3.84	26.6	86.4	3.0
30	15.00	2.8	6.5	60.6	42.0	2.57	69.4	23.6	44.5	3.94	31.0	88.6	3.3
	22.50	5.9	13.6	59.2	40.9	2.49	67.7	23.8	45.4	3.96	31.9	89.0	3.4
	30.00	9.0	20.8	58.5	40.4	2.45	66.9	23.9	45.9	3.97	32.3	89.2	3.4
40	15.00	2.7	6.2	63.9	44.4	2.85	73.6	22.4	51.2	4.10	37.2	91.6	3.7
	22.50	5.6	12.8	63.0	43.8	2.76	72.4	22.9	52.4	4.12	38.3	92.2	3.7
	30.00	8.4	19.4	62.5	43.4	2.71	71.8	23.0	53.1	4.14	38.9	92.5	3.8
50	15.00	2.6	6.0	65.5	45.8	3.14	76.2	20.9	58.6	4.27	44.0	95.0	4.0
	22.50	5.3	12.2	65.1	45.4	3.04	75.5	21.4	60.1	4.30	45.4	95.8	4.1
	30.00	8.0	18.4	64.9	45.2	2.99	75.1	21.7	60.9	4.32	46.1	96.1	4.1
60	15.00	2.5	5.9	65.8	46.2	3.45	77.6	19.1	66.3	4.45	51.1	98.6	4.4
	22.50	5.1	11.8	65.9	46.1	3.34	77.3	19.7	68.1	4.50	52.8	99.5	4.4
	30.00	7.7	17.7	65.8	46.1	3.29	77.0	20.0	69.1	4.52	53.6	99.9	4.5
70	15.00	2.5	5.7	65.0	45.9	3.81	78.0	17.1	74.1	4.64	58.2	102.2	4.7
	22.50	5.0	11.5	65.4	46.1	3.68	78.0	17.8	76.1	4.69	60.1	103.2	4.8
	30.00	7.4	17.2	65.6	46.1	3.62	77.9	18.1	77.2	4.72	61.1	103.7	4.8
80	15.00	2.4	5.6	63.3	45.2	4.20	77.7	15.1	81.7	4.83	65.2	105.7	5.0
	22.50	4.9	11.2	64.0	45.5	4.06	77.9	15.8	83.9	4.89	67.2	106.7	5.0
	30.00	7.3	16.8	64.3	45.6	3.99	77.9	16.1	85.0	4.92	68.2	107.3	5.1
90	15.00	2.4	5.5	60.9	44.1	4.66	76.8	13.1	88.8	5.01	71.7	109.0	5.2
	22.50	4.8	11.0	61.8	44.5	4.50	77.1	13.7	91.0	5.07	73.7	110.0	5.3
	30.00	7.1	16.5	62.2	44.7	4.42	77.3	14.1	92.0	5.10	74.7	110.5	5.3
100	15.00	2.3	5.3	57.9	42.9	5.18	75.6	11.2	Operation Not Recommended				
	22.50	4.6	10.7	59.0	43.3	5.00	76.0	11.8					
	30.00	7.0	16.1	59.5	43.5	4.91	76.2	12.1					
110	15.00	2.2	5.1	54.5	41.5	5.78	74.3	9.4					
	22.50	4.5	10.4	55.7	42.0	5.58	74.7	10.0					
	30.00	6.8	15.7	56.2	42.2	5.47	74.9	10.3					
120	15.00	2.0	4.7	50.9	40.2	6.47	73.0	7.9					
	22.50	4.3	9.9	52.1	40.6	6.24	73.4	8.4					
	30.00	6.6	15.1	52.7	40.9	6.12	73.6	8.6					

Notes:

- Interpolation is permissible, extrapolation is not.
- All entering air conditions are 80°F (26.6°C) DB and 67°F (19.4°C) WB in cooling, and 70°F (21°C) DB in heating.
- AHRI/ISO certified conditions are 80.6°F (27°C) DB and 66.2°F (19°C) WB in cooling and 68°F (20°C) DB in heating.
- Table does not reflect fan or pump power corrections for AHRI/ISO conditions.
- All performance data is based on the lower voltage of dual voltage units.
- Performance stated is at the rated power supply; performance may vary as the power supply varies from the rated.
- Operation below 40°F EWT is based on a 15% methanol antifreeze solution.
- Operation below 60°F EWT requires optional insulated water/refrigerant circuit.
- See performance correction tables for operating conditions other than those listed above.
- See Performance Data Selection Notes for operation in the shaded areas.

Performance Data MB168 Vertical Full Load

Models:
MB
072-300

5,600 CFM Rated Airflow

EWT °F	WPD			Cooling - EAT 80/67°F									Heating - EAT 70°F									
	FLOW GPM	PSI	FT	TC	SC	3-Phase Std Motor			VFD			3-Phase Std Motor				VFD						
						Power kW	HR	EER	Power kW	HR	EER	HC	Power kW	HE	LAT	COP	HC	Power kW	HE	LAT	COP	
20	Operation Not Recommended																					
30	21.00	1.4	3.2	194.0	140.6	7.21	218.6	26.9	7.02	218.0	27.6	112.8	11.2	74.5	86.6	2.9	112.2	11.04	74.5	86.5	3.0	
	31.50	2.7	6.3	192.5	139.9	6.75	215.5	28.5	6.56	214.8	29.3	117.3	11.3	78.7	87.4	3.0	116.7	11.14	78.7	87.2	3.1	
	42.00	4.5	10.3	191.0	139.3	6.56	213.4	29.1	6.37	212.7	30.0	119.8	11.4	81.0	87.8	3.1	119.2	11.19	81.0	87.7	3.1	
40	21.00	1.3	3.0	193.4	140.7	8.03	220.8	24.1	7.84	220.2	24.7	131.4	11.6	91.8	89.7	3.3	130.8	11.43	91.8	89.6	3.4	
	31.50	2.6	6.0	194.2	140.7	7.44	219.6	26.1	7.25	218.9	26.8	137.4	11.8	97.3	90.7	3.4	136.7	11.56	97.3	90.6	3.5	
	42.00	4.2	9.8	194.0	140.6	7.18	218.5	27.0	6.99	217.9	27.7	140.7	11.8	100.4	91.2	3.5	140.1	11.63	100.4	91.1	3.5	
50	21.00	1.3	2.9	190.1	139.7	9.00	220.8	21.1	8.81	220.1	21.6	151.1	12.1	109.9	92.9	3.7	150.4	11.86	109.9	92.8	3.7	
	31.50	2.5	5.7	192.7	140.5	8.30	221.0	23.2	8.11	220.4	23.7	158.5	12.2	116.8	94.1	3.8	157.8	12.03	116.8	94.0	3.8	
	42.00	4.1	9.3	193.5	140.7	7.99	220.8	24.2	7.80	220.1	24.8	162.6	12.3	120.6	94.8	3.9	162.0	12.13	120.6	94.7	3.9	
60	21.00	1.2	2.8	184.7	137.9	10.09	219.1	18.3	9.90	218.5	18.6	171.2	12.5	128.5	96.2	4.0	170.6	12.33	128.5	96.1	4.1	
	31.50	2.4	5.5	188.6	139.3	9.31	220.4	20.3	9.12	219.8	20.7	180.0	12.7	136.6	97.7	4.1	179.4	12.54	136.6	97.6	4.2	
	42.00	3.9	9.0	190.3	139.8	8.95	220.8	21.3	8.76	220.2	21.7	184.9	12.8	141.0	98.5	4.2	184.2	12.66	141.0	98.4	4.3	
70	21.00	1.2	2.7	177.8	135.4	11.31	216.4	15.7	11.12	215.8	16.0	191.5	13.0	147.1	99.6	4.3	190.9	12.82	147.1	99.5	4.4	
	31.50	2.3	5.4	182.7	137.2	10.46	218.4	17.5	10.27	217.7	17.8	201.5	13.3	156.2	101.2	4.5	200.8	13.07	156.2	101.1	4.5	
	42.00	3.8	8.8	184.9	138.0	10.05	219.2	18.4	9.86	218.6	18.8	206.8	13.4	161.1	102.1	4.5	206.2	13.20	161.1	102.0	4.6	
80	21.00	1.2	2.7	170.1	132.2	12.63	213.2	13.5	12.44	212.5	13.7	211.4	13.5	165.3	102.9	4.6	210.8	13.32	165.3	102.8	4.6	
	31.50	2.3	5.3	175.4	134.4	11.72	215.4	15.0	11.53	214.8	15.2	222.2	13.8	175.1	104.6	4.7	221.5	13.59	175.1	104.5	4.8	
	42.00	3.8	8.7	178.0	135.5	11.28	216.5	15.8	11.09	215.9	16.1	227.9	13.9	180.3	105.6	4.8	227.2	13.74	180.3	105.5	4.8	
90	21.00	1.1	2.6	161.9	128.4	14.06	209.8	11.5	13.87	209.2	11.7	230.5	14.0	182.7	106.0	4.8	229.8	13.81	182.7	105.9	4.9	
	31.50	2.2	5.2	167.4	131.0	13.09	212.1	12.8	12.90	211.4	13.0	241.5	14.3	192.7	107.8	4.9	240.9	14.11	192.7	107.7	5.0	
	42.00	3.7	8.5	170.2	132.2	12.62	213.2	13.5	12.43	212.6	13.7	247.2	14.5	197.9	108.8	5.0	246.6	14.27	197.9	108.7	5.1	
100	21.00	1.1	2.6	153.8	124.4	15.57	206.9	9.9	15.38	206.3	10.0	Operation Not Recommended										
	31.50	2.2	5.1	159.1	127.1	14.56	208.8	10.9	14.37	208.1	11.1											
	42.00	3.6	8.4	161.9	128.4	14.06	209.8	11.5	13.87	209.2	11.7											
110	21.00	1.1	2.5	146.3	120.3	17.17	204.9	8.5	16.98	204.2	8.6											
	31.50	2.1	5.0	151.1	122.9	16.12	206.1	9.4	15.93	205.4	9.5											
	42.00	3.6	8.2	153.7	124.3	15.60	206.9	9.9	15.41	206.2	10.0											
120	21.00	1.1	2.4	139.9	116.4	18.85	204.2	7.4	18.66	203.6	7.5											
	31.50	2.1	4.8	143.9	118.9	17.75	204.5	8.1	17.56	203.8	8.2											
	42.00	3.4	8.0	146.1	120.1	17.21	204.8	8.5	17.02	204.2	8.6											

Notes:

- Interpolation is permissible, extrapolation is not.
- All entering air conditions are 80°F (26.6°C) DB and 67°F (19.4°C) WB in cooling, and 70°F (21°C) DB in heating.
- AHRI/ISO certified conditions are 80.6°F (27°C) DB and 66.2°F (19°C) WB in cooling and 68°F (20°C) DB in heating.
- Table does not reflect fan or pump power corrections for AHRI/ISO conditions.
- All performance data is based on the lower voltage of dual voltage units.
- Performance stated is at the rated power supply; performance may vary as the power supply varies from the rated.
- Operation below 40°F EWT is based on a 15% methanol antifreeze solution.
- Operation below 60°F EWT requires optional insulated water/refrigerant circuit.
- See performance correction tables for operating conditions other than those listed above.
- See Performance Data Selection Notes for operation in the shaded areas.

Performance Data MB168 Vertical Part Load (VFD)

Models:
MB
072-300

2,800 CFM Rated Airflow

EWT °F	WPD			Cooling - EAT 80/67°F					Heating - EAT 70°F				
	FLOW GPM	PSI	FT	TC	SC	VFD			VFD				
						Power kW	HR	EER	HC	Power kW	HE	LAT	COP
20	Operation Not Recommended												
30	10.50	1.3	2.9	97.6	71.1	3.02	107.9	32.3	54.6	5.16	37.0	86.0	3.1
	15.75	2.4	5.6	96.9	70.3	2.79	106.4	34.7	56.8	5.22	39.0	86.7	3.2
	21.00	3.8	8.7	96.1	69.7	2.69	105.3	35.7	58.0	5.25	40.1	87.1	3.2
40	10.50	1.1	2.6	97.2	71.4	3.44	108.9	28.3	63.8	5.39	45.4	89.0	3.5
	15.75	2.1	4.9	97.7	71.3	3.14	108.4	31.1	66.7	5.46	48.1	90.0	3.6
	21.00	3.5	8.0	97.6	71.1	3.01	107.9	32.4	68.3	5.51	49.6	90.5	3.6
50	10.50	1.0	2.4	95.3	70.9	3.92	108.7	24.3	73.6	5.64	54.3	92.3	3.8
	15.75	2.0	4.5	96.7	71.3	3.58	108.9	27.0	77.3	5.73	57.7	93.5	4.0
	21.00	3.2	7.4	97.2	71.4	3.42	108.9	28.4	79.3	5.78	59.6	94.2	4.0
60	10.50	1.0	2.3	92.3	69.8	4.48	107.6	20.6	83.7	5.89	63.6	95.6	4.2
	15.75	1.9	4.3	94.4	70.6	4.09	108.4	23.1	88.0	6.00	67.5	97.0	4.3
	21.00	3.1	7.1	95.4	71.0	3.91	108.7	24.4	90.4	6.06	69.7	97.8	4.4
70	10.50	1.0	2.2	88.6	68.2	5.08	105.9	17.4	93.7	6.15	72.7	98.9	4.5
	15.75	1.8	4.2	91.2	69.4	4.67	107.1	19.5	98.6	6.28	77.1	100.5	4.6
	21.00	3.0	6.8	92.4	69.9	4.46	107.6	20.7	101.2	6.34	79.5	101.4	4.7
80	10.50	0.9	2.2	84.4	66.3	5.74	104.0	14.7	103.5	6.41	81.6	102.1	4.7
	15.75	1.8	4.2	87.2	67.6	5.30	105.3	16.5	108.6	6.55	86.2	103.8	4.9
	21.00	2.9	6.7	88.6	68.2	5.08	106.0	17.5	111.2	6.62	88.6	104.7	4.9
90	10.50	0.9	2.1	80.0	64.2	6.44	102.0	12.4	112.6	6.66	89.9	105.1	5.0
	15.75	1.8	4.1	82.9	65.6	5.98	103.3	13.9	117.6	6.80	94.4	106.8	5.1
	21.00	2.9	6.6	84.4	66.3	5.75	104.0	14.7	120.1	6.88	96.6	107.6	5.1
100	10.50	0.9	2.1	75.7	62.0	7.18	100.3	10.5	Operation Not Recommended				
	15.75	1.7	4.0	78.5	63.4	6.70	101.4	11.7					
	21.00	2.8	6.5	79.9	64.1	6.46	102.0	12.4					
110	10.50	0.9	2.0	71.8	60.0	7.96	99.0	9.0					
	15.75	1.6	3.7	74.2	61.2	7.46	99.7	9.9					
	21.00	2.7	6.3	75.6	61.9	7.22	100.2	10.5					
120	10.50	0.8	1.9	68.5	58.4	8.77	98.4	7.8					
	15.75	1.4	3.3	70.5	59.3	8.26	98.6	8.5					
	21.00	2.6	6.1	71.6	59.9	8.01	98.9	8.9					

Notes:

- Interpolation is permissible, extrapolation is not.
- All entering air conditions are 80°F (26.6°C) DB and 67°F (19.4°C) WB in cooling, and 70°F (21°C) DB in heating.
- AHRI/ISO certified conditions are 80.6°F (27°C) DB and 66.2°F (19°C) WB in cooling and 68°F (20°C) DB in heating.
- Table does not reflect fan or pump power corrections for AHRI/ISO conditions.
- All performance data is based on the lower voltage of dual voltage units.
- Performance stated is at the rated power supply; performance may vary as the power supply varies from the rated.
- Operation below 40°F EWT is based on a 15% methanol antifreeze solution.
- Operation below 60°F EWT requires optional insulated water/refrigerant circuit.
- See performance correction tables for operating conditions other than those listed above.
- See Performance Data Selection Notes for operation in the shaded areas.

Performance Data MB192 Vertical Full Load

Models:
MB
072-300

6,400 CFM Rated Airflow

EWT °F	WPD			Cooling - EAT 80/67°F									Heating - EAT 70°F										
	FLOW GPM	PSI	FT	TC	SC	3-Phase Std Motor			VFD			3-Phase Std Motor				VFD							
						Power kW	HR	EER	Power kW	HR	EER	HC	Power kW	HE	LAT	COP	HC	Power kW	HE	LAT	COP		
20	Operation Not Recommended																						
30	24.00	2.2	5.0	209.8	154.7	8.30	238.1	25.3	8.29	238.1	25.3	133.0	11.9	92.6	87.2	3.3	133.0	11.85	92.6	87.2	3.3		
	36.00	4.8	11.0	207.4	151.9	7.94	234.5	26.1	7.94	234.5	26.1	138.0	12.0	97.2	87.9	3.4	138.0	11.95	97.2	87.9	3.4		
	48.00	7.4	17.0	205.5	150.0	7.81	232.1	26.3	7.80	232.1	26.3	140.7	12.0	99.7	88.3	3.4	140.7	12.01	99.7	88.3	3.4		
40	24.00	2.1	4.8	210.2	156.9	9.02	241.0	23.3	9.02	240.9	23.3	152.2	12.2	110.4	90.0	3.6	152.2	12.24	110.4	90.0	3.6		
	36.00	4.5	10.5	210.4	155.7	8.52	239.4	24.7	8.51	239.4	24.7	158.8	12.4	116.5	90.9	3.8	158.8	12.38	116.5	90.9	3.8		
	48.00	7.0	16.1	209.8	154.7	8.30	238.2	25.3	8.30	238.1	25.3	162.4	12.5	119.9	91.4	3.8	162.4	12.45	119.9	91.4	3.8		
50	24.00	2.0	4.7	207.3	157.0	9.93	241.2	20.9	9.93	241.2	20.9	173.0	12.7	129.8	93.0	4.0	173.0	12.67	129.8	93.0	4.0		
	36.00	4.4	10.1	209.5	157.1	9.30	241.3	22.5	9.30	241.3	22.5	181.2	12.8	137.4	94.2	4.1	181.2	12.84	137.4	94.2	4.1		
	48.00	6.7	15.4	210.2	156.9	9.02	241.0	23.3	9.01	240.9	23.3	185.8	12.9	141.6	94.8	4.2	185.8	12.93	141.6	94.8	4.2		
60	24.00	2.0	4.6	201.9	155.4	11.01	239.5	18.3	11.00	239.5	18.4	194.8	13.1	150.0	96.1	4.4	194.8	13.11	150.0	96.1	4.4		
	36.00	4.2	9.8	205.8	156.6	10.27	240.8	20.0	10.26	240.8	20.0	204.5	13.3	159.1	97.5	4.5	204.5	13.31	159.1	97.5	4.5		
	48.00	6.5	15.0	207.3	157.0	9.93	241.2	20.9	9.92	241.2	20.9	209.8	13.4	164.0	98.3	4.6	209.8	13.42	164.0	98.3	4.6		
70	24.00	2.0	4.5	194.7	152.6	12.23	236.4	15.9	12.23	236.4	15.9	216.8	13.6	170.5	99.3	4.7	216.8	13.56	170.5	99.3	4.7		
	36.00	4.2	9.6	199.7	154.6	11.41	238.6	17.5	11.40	238.6	17.5	227.8	13.8	180.8	100.9	4.8	227.8	13.77	180.8	100.9	4.8		
	48.00	6.4	14.7	201.9	155.4	11.01	239.5	18.3	11.01	239.5	18.3	233.7	13.9	186.3	101.7	4.9	233.7	13.88	186.3	101.7	4.9		
80	24.00	1.9	4.5	186.2	148.8	13.60	232.6	13.7	13.59	232.6	13.7	238.5	14.0	190.8	102.4	5.0	238.5	13.97	190.8	102.4	5.0		
	36.00	4.1	9.5	191.9	151.4	12.69	235.2	15.1	12.69	235.2	15.1	250.2	14.2	201.8	104.1	5.2	250.2	14.19	201.8	104.1	5.2		
	48.00	6.3	14.4	194.6	152.5	12.25	236.4	15.9	12.25	236.4	15.9	256.4	14.3	207.6	105.0	5.3	256.4	14.30	207.6	105.0	5.3		
90	24.00	1.9	4.4	177.0	144.5	15.09	228.4	11.7	15.08	228.4	11.7	259.1	14.3	210.1	105.4	5.3	259.1	14.34	210.1	105.4	5.3		
	36.00	4.0	9.3	183.0	147.3	14.12	231.1	13.0	14.11	231.1	13.0	270.9	14.5	221.3	107.1	5.5	270.9	14.54	221.3	107.1	5.5		
	48.00	6.2	14.3	185.9	148.7	13.64	232.5	13.6	13.64	232.5	13.6	277.0	14.6	227.1	108.0	5.5	277.0	14.63	227.1	108.0	5.5		
100	24.00	1.9	4.3	167.5	139.9	16.69	224.4	10.0	16.69	224.4	10.0	Operation Not Recommended											
	36.00	4.0	9.2	173.5	142.8	15.67	226.9	11.1	15.66	226.9	11.1												
	48.00	6.1	14.0	176.5	144.3	15.16	228.2	11.6	15.16	228.2	11.6												
110	24.00	1.8	4.2	158.3	135.5	18.41	221.1	8.6	18.41	221.1	8.6												
	36.00	3.9	9.0	163.9	138.2	17.33	223.1	9.5	17.33	223.0	9.5												
	48.00	5.9	13.7	166.9	139.6	16.80	224.2	9.9	16.80	224.2	9.9												
120	24.00	1.7	4.0	149.9	131.6	20.23	218.9	7.4	20.23	218.9	7.4												
	36.00	3.7	8.6	154.9	133.9	19.11	220.1	8.1	19.10	220.1	8.1												
	48.00	5.7	13.2	157.6	135.1	18.55	220.9	8.5	18.55	220.8	8.5												

Notes:

- Interpolation is permissible, extrapolation is not.
- All entering air conditions are 80°F (26.6°C) DB and 67°F (19.4°C) WB in cooling, and 70°F (21°C) DB in heating.
- AHRI/ISO certified conditions are 80.6°F (27°C) DB and 66.2°F (19°C) WB in cooling and 68°F (20°C) DB in heating.
- Table does not reflect fan or pump power corrections for AHRI/ISO conditions.
- All performance data is based on the lower voltage of dual voltage units.
- Performance stated is at the rated power supply; performance may vary as the power supply varies from the rated.
- Operation below 40°F EWT is based on a 15% methanol antifreeze solution.
- Operation below 60°F EWT requires optional insulated water/refrigerant circuit.
- See performance correction tables for operating conditions other than those listed above.
- See Performance Data Selection Notes for operation in the shaded areas.

Performance Data MB192 Vertical Part Load (VFD)

Models:
MB
072-300

3,200 CFM Rated Airflow

EWT °F	WPD			Cooling - EAT 80/67°F					Heating - EAT 70°F				
	FLOW GPM	PSI	FT	TC	SC	VFD			VFD				
						Power kW	HR	EER	HC	Power kW	HE	LAT	COP
20	Operation Not Recommended												
30	12.00	2.0	4.5	99.7	77.1	3.23	110.7	30.9	62.1	5.43	43.6	85.9	3.4
	18.00	4.1	9.4	94.5	73.5	2.88	104.3	32.9	64.6	5.48	45.9	86.6	3.5
	24.00	6.2	14.3	91.3	71.3	2.71	100.5	33.7	65.9	5.51	47.1	87.0	3.5
40	12.00	1.8	4.2	104.0	80.3	3.81	117.0	27.3	71.7	5.63	52.5	88.7	3.7
	18.00	3.8	8.7	101.9	78.7	3.45	113.6	29.6	74.6	5.70	55.2	89.5	3.8
	24.00	5.7	13.2	100.2	77.5	3.27	111.4	30.6	76.2	5.73	56.6	90.0	3.9
50	12.00	1.7	4.0	104.2	81.1	4.38	119.2	23.8	81.2	5.84	61.3	91.4	4.1
	18.00	3.6	8.2	104.5	80.8	4.01	118.1	26.1	84.6	5.91	64.5	92.4	4.2
	24.00	5.4	12.4	104.0	80.4	3.82	117.1	27.2	86.4	5.94	66.1	92.9	4.3
60	12.00	1.7	3.8	101.9	80.2	4.96	118.8	20.5	90.6	6.03	70.0	94.2	4.4
	18.00	3.4	7.8	103.7	80.9	4.57	119.3	22.7	94.4	6.11	73.6	95.3	4.5
	24.00	5.1	11.9	104.2	81.1	4.38	119.2	23.8	96.4	6.15	75.4	95.8	4.6
70	12.00	1.6	3.7	97.8	78.3	5.56	116.7	17.6	99.8	6.22	78.6	96.8	4.7
	18.00	3.3	7.6	100.6	79.7	5.16	118.2	19.5	103.9	6.31	82.4	98.0	4.8
	24.00	5.0	11.5	101.8	80.2	4.96	118.8	20.5	106.0	6.35	84.4	98.6	4.9
80	12.00	1.6	3.7	92.7	75.8	6.21	113.9	14.9	108.6	6.40	86.8	99.4	5.0
	18.00	3.2	7.4	96.1	77.5	5.79	115.8	16.6	112.9	6.49	90.7	100.6	5.1
	24.00	4.9	11.2	97.6	78.3	5.58	116.7	17.5	115.1	6.53	92.8	101.2	5.2
90	12.00	1.6	3.6	87.4	73.0	6.91	111.0	12.7	116.9	6.57	94.5	101.8	5.2
	18.00	3.2	7.3	90.7	74.8	6.46	112.8	14.0	121.2	6.65	98.5	103.0	5.3
	24.00	4.8	11.0	92.5	75.6	6.24	113.8	14.8	123.4	6.70	100.5	103.6	5.4
100	12.00	1.5	3.5	82.3	70.4	7.68	108.5	10.7	Operation Not Recommended				
	18.00	3.1	7.2	85.3	71.9	7.20	109.9	11.9					
	24.00	4.7	10.8	87.0	72.8	6.96	110.7	12.5					
110	12.00	1.5	3.4	78.2	68.4	8.55	107.4	9.1					
	18.00	3.0	7.0	80.5	69.5	8.02	107.9	10.0					
120	24.00	4.6	10.6	81.9	70.1	7.76	108.3	10.6					
	12.00	1.4	3.2	75.8	68.0	9.55	108.4	7.9					
	18.00	2.9	6.7	77.0	68.0	8.93	107.5	8.6					
	24.00	4.4	10.2	77.8	68.3	8.65	107.4	9.0					

Notes:

- Interpolation is permissible, extrapolation is not.
- All entering air conditions are 80°F (26.6°C) DB and 67°F (19.4°C) WB in cooling, and 70°F (21°C) DB in heating.
- AHRI/ISO certified conditions are 80.6°F (27°C) DB and 66.2°F (19°C) WB in cooling and 68°F (20°C) DB in heating.
- Table does not reflect fan or pump power corrections for AHRI/ISO conditions.
- All performance data is based on the lower voltage of dual voltage units.
- Performance stated is at the rated power supply; performance may vary as the power supply varies from the rated.
- Operation below 40°F EWT is based on a 15% methanol antifreeze solution.
- Operation below 60°F EWT requires optional insulated water/refrigerant circuit.
- See performance correction tables for operating conditions other than those listed above.
- See Performance Data Selection Notes for operation in the shaded areas.

Performance Data MB240 Vertical Full Load

Models:
MB
072-300

8,000 CFM Rated Airflow

EWT °F	WPD			Cooling - EAT 80/67°F									Heating - EAT 70°F									
	FLOW GPM	PSI	FT	TC	SC	3-Phase Std Motor			VFD			3-Phase Std Motor				VFD						
						Power kW	HR	EER	Power kW	HR	EER	HC	Power kW	HE	LAT	COP	HC	Power kW	HE	LAT	COP	
20	Operation Not Recommended																					
30	30.00	1.8	4.2	249.6	187.5	11.51	288.9	21.7	11.33	288.2	22.0	162.5	16.2	107.1	86.8	2.9	161.8	16.04	107.1	86.7	3.0	
	45.00	4.2	9.6	245.1	185.1	10.84	282.1	22.6	10.66	281.5	23.0	167.4	16.2	112.1	87.3	3.0	166.8	16.01	112.1	87.3	3.1	
	60.00	6.5	15.1	242.1	183.5	10.53	278.1	23.0	10.35	277.4	23.4	170.2	16.2	115.0	87.7	3.1	169.6	16.01	115.0	87.6	3.1	
40	30.00	1.7	3.8	252.7	189.3	12.64	295.8	20.0	12.46	295.2	20.3	184.8	16.3	129.0	89.3	3.3	184.1	16.15	129.0	89.3	3.3	
	45.00	3.9	8.9	251.2	188.4	11.90	291.8	21.1	11.72	291.2	21.4	192.7	16.5	136.5	90.3	3.4	192.1	16.28	136.5	90.2	3.5	
	60.00	6.1	14.0	249.8	187.6	11.55	289.2	21.6	11.37	288.6	22.0	197.2	16.6	140.7	90.8	3.5	196.6	16.37	140.7	90.7	3.5	
50	30.00	1.6	3.6	251.6	189.0	13.87	298.9	18.1	13.68	298.3	18.4	212.5	16.9	154.8	92.5	3.7	211.9	16.72	154.8	92.5	3.7	
	45.00	3.6	8.4	252.8	189.4	13.05	297.3	19.4	12.86	296.6	19.6	223.6	17.2	164.9	93.8	3.8	222.9	17.01	164.9	93.7	3.8	
	60.00	5.7	13.2	252.7	189.3	12.66	295.9	20.0	12.48	295.3	20.3	229.8	17.4	170.6	94.5	3.9	229.2	17.19	170.6	94.5	3.9	
60	30.00	1.5	3.5	247.0	187.2	15.22	298.9	16.2	15.03	298.3	16.4	243.5	17.8	182.9	96.1	4.0	242.9	17.58	182.9	96.1	4.0	
	45.00	3.5	8.0	250.4	188.5	14.31	299.2	17.5	14.12	298.6	17.7	257.6	18.2	195.6	97.7	4.2	257.0	18.00	195.6	97.7	4.2	
	60.00	5.4	12.6	251.6	189.0	13.87	298.9	18.1	13.69	298.3	18.4	265.5	18.4	202.6	98.7	4.2	264.9	18.24	202.6	98.6	4.3	
70	30.00	1.5	3.4	239.6	184.0	16.71	296.6	14.3	16.53	296.0	14.5	276.2	18.8	212.2	99.9	4.3	275.6	18.57	212.2	99.8	4.3	
	45.00	3.4	7.8	244.8	186.2	15.70	298.4	15.6	15.52	297.7	15.8	292.7	19.3	227.0	101.8	4.5	292.1	19.07	227.0	101.7	4.5	
	60.00	5.3	12.1	247.0	187.1	15.22	298.9	16.2	15.04	298.3	16.4	301.9	19.5	235.2	102.9	4.5	301.2	19.34	235.2	102.8	4.6	
80	30.00	1.5	3.4	229.9	179.9	18.37	292.5	12.5	18.19	291.9	12.6	308.8	19.7	241.5	103.7	4.6	308.2	19.55	241.5	103.6	4.6	
	45.00	3.3	7.6	236.5	182.7	17.26	295.4	13.7	17.08	294.7	13.8	326.9	20.2	257.9	105.7	4.7	326.3	20.05	257.9	105.7	4.8	
	60.00	5.1	11.8	239.5	184.0	16.73	296.5	14.3	16.55	295.9	14.5	336.5	20.5	266.7	106.9	4.8	335.9	20.30	266.7	106.8	4.9	
90	30.00	1.4	3.3	218.3	174.7	20.23	287.3	10.8	20.05	286.7	10.9	339.8	20.6	269.7	107.2	4.8	339.2	20.38	269.7	107.2	4.9	
	45.00	3.2	7.4	225.9	178.1	19.01	290.8	11.9	18.83	290.2	12.0	358.0	20.9	286.5	109.3	5.0	357.4	20.76	286.5	109.3	5.0	
	60.00	5.0	11.6	229.6	179.7	18.42	292.4	12.5	18.24	291.8	12.6	367.1	21.1	295.2	110.4	5.1	366.5	20.90	295.2	110.3	5.1	
100	30.00	1.4	3.2	205.3	168.8	22.31	281.5	9.2	22.12	280.8	9.3	Operation Not Recommended										
	45.00	3.2	7.3	213.7	172.6	20.97	285.2	10.2	20.78	284.6	10.3											
	60.00	4.9	11.4	217.7	174.5	20.32	287.1	10.7	20.14	286.4	10.8											
110	30.00	1.3	2.9	191.4	162.1	24.63	275.4	7.8	24.45	274.8	7.8											
	45.00	3.1	7.1	200.1	166.3	23.16	279.1	8.6	22.98	278.5	8.7											
	60.00	4.8	11.2	204.5	168.3	22.45	281.1	9.1	22.27	280.4	9.2											
120	30.00	1.1	2.5	176.8	154.7	27.23	269.7	6.5	27.05	269.0	6.5											
	45.00	2.9	6.7	185.7	159.2	25.62	273.1	7.2	25.44	272.5	7.3											
	60.00	4.7	10.9	190.1	161.5	24.84	274.9	7.7	24.66	274.3	7.7											

Notes:

- Interpolation is permissible, extrapolation is not.
- All entering air conditions are 80°F (26.6°C) DB and 67°F (19.4°C) WB in cooling, and 70°F (21°C) DB in heating.
- AHRI/ISO certified conditions are 80.6°F (27°C) DB and 66.2°F (19°C) WB in cooling and 68°F (20°C) DB in heating.
- Table does not reflect fan or pump power corrections for AHRI/ISO conditions.
- All performance data is based on the lower voltage of dual voltage units.
- Performance stated is at the rated power supply; performance may vary as the power supply varies from the rated.
- Operation below 40°F EWT is based on a 15% methanol antifreeze solution.
- Operation below 60°F EWT requires optional insulated water/refrigerant circuit.
- See performance correction tables for operating conditions other than those listed above.
- See Performance Data Selection Notes for operation in the shaded areas.

Performance Data MB240 Vertical Part Load (VFD)

Models:
MB
072-300

4,000 CFM Rated Airflow

EWT °F	WPD			Cooling - EAT 80/67°F					Heating - EAT 70°F				
	FLOW GPM	PSI	FT	TC	SC	VFD			VFD				
						Power kW	HR	EER	HC	Power kW	HE	LAT	COP
20	Operation Not Recommended												
30	15.00	1.5	3.5	125.7	95.1	4.77	142.0	26.4	80.4	7.53	54.7	86.6	3.1
	22.50	3.2	7.5	122.6	92.6	4.48	137.8	27.4	83.3	7.58	57.5	87.2	3.2
	30.00	5.0	11.5	120.5	91.0	4.35	135.3	27.7	85.0	7.62	59.0	87.6	3.3
40	15.00	1.4	3.2	127.9	97.2	5.29	146.0	24.2	92.5	7.76	66.1	89.4	3.5
	22.50	3.0	6.9	126.9	96.1	4.95	143.8	25.6	96.6	7.84	69.8	90.3	3.6
	30.00	4.6	10.7	125.9	95.2	4.79	142.3	26.3	98.8	7.88	71.9	90.8	3.7
50	15.00	1.3	2.9	127.2	97.6	5.88	147.3	21.6	105.9	8.03	78.5	92.5	3.9
	22.50	2.8	6.5	127.9	97.6	5.49	146.7	23.3	111.0	8.13	83.3	93.6	4.0
	30.00	4.4	10.1	127.9	97.3	5.31	146.0	24.1	113.9	8.19	85.9	94.3	4.1
60	15.00	1.2	2.8	124.4	96.7	6.54	146.7	19.0	120.0	8.32	91.6	95.7	4.2
	22.50	2.7	6.2	126.4	97.5	6.10	147.2	20.7	126.2	8.46	97.4	97.2	4.4
	30.00	4.2	9.6	127.2	97.6	5.89	147.3	21.6	129.7	8.54	100.5	97.9	4.5
70	15.00	1.2	2.7	120.1	94.9	7.26	144.9	16.5	134.5	8.65	105.0	99.1	4.6
	22.50	2.6	6.0	123.0	96.2	6.78	146.2	18.1	141.7	8.82	111.7	100.7	4.7
	30.00	4.0	9.2	124.3	96.7	6.55	146.7	19.0	145.7	8.91	115.3	101.7	4.8
80	15.00	1.1	2.6	114.7	92.4	8.07	142.3	14.2	149.1	8.99	118.4	102.4	4.9
	22.50	2.5	5.8	118.2	94.1	7.54	144.0	15.7	157.1	9.20	125.8	104.3	5.0
	30.00	3.9	8.9	119.9	94.8	7.29	144.8	16.4	161.5	9.31	129.7	105.3	5.1
90	15.00	1.1	2.6	108.8	89.5	8.96	139.4	12.1	163.4	9.36	131.5	105.7	5.1
	22.50	2.4	5.6	112.6	91.4	8.39	141.2	13.4	172.0	9.59	139.2	107.7	5.3
	30.00	3.8	8.7	114.4	92.3	8.11	142.1	14.1	176.5	9.72	143.3	108.8	5.3
100	15.00	1.1	2.6	102.7	86.6	9.95	136.6	10.3	Operation Not Recommended				
	22.50	2.4	5.5	106.4	88.4	9.33	138.3	11.4					
	30.00	3.7	8.5	108.3	89.3	9.03	139.1	12.0					
110	15.00	1.1	2.5	96.8	83.8	11.04	134.5	8.8					
	22.50	2.4	5.4	100.3	85.4	10.37	135.7	9.7					
	30.00	3.6	8.3	102.1	86.3	10.04	136.4	10.2					
120	15.00	1.1	2.5	91.6	81.6	12.26	133.5	7.5					
	22.50	2.3	5.3	94.6	82.8	11.52	133.9	8.2					
	30.00	3.5	8.1	96.2	83.5	11.16	134.3	8.6					

Notes:

- Interpolation is permissible, extrapolation is not.
- All entering air conditions are 80°F (26.6°C) DB and 67°F (19.4°C) WB in cooling, and 70°F (21°C) DB in heating.
- AHRI/ISO certified conditions are 80.6°F (27°C) DB and 66.2°F (19°C) WB in cooling and 68°F (20°C) DB in heating.
- Table does not reflect fan or pump power corrections for AHRI/ISO conditions.
- All performance data is based on the lower voltage of dual voltage units.
- Performance stated is at the rated power supply; performance may vary as the power supply varies from the rated.
- Operation below 40°F EWT is based on a 15% methanol antifreeze solution.
- Operation below 60°F EWT requires optional insulated water/refrigerant circuit.
- See performance correction tables for operating conditions other than those listed above.
- See Performance Data Selection Notes for operation in the shaded areas.

Performance Data MB300 Vertical Full Load

Models:
MB
072-300

10,000 CFM Rated Airflow

EWT °F	WPD			Cooling - EAT 80/67°F									Heating - EAT 70°F												
	FLOW GPM	PSI	FT	TC	SC	3-Phase Std Motor			VFD			3-Phase Std Motor				VFD									
						Power kW	HR	EER	Power kW	HR	EER	HC	Power kW	HE	LAT	COP	HC	Power kW	HE	LAT	COP				
20	Operation Not Recommended																								
30	37.50	2.4	5.5	335.7	253.1	17.1	394.0	19.6	16.9	393.5	20.0	212.7	22.9	134.6	89.2	2.7	212.2	22.7	134.6	89.2	2.7				
	56.25	5.4	12.4	334.0	256.5	16.8	391.4	19.9	16.7	390.9	19.9	222.2	23.0	143.6	90.1	2.8	221.7	22.9	143.6	90.1	2.8				
	75.00	8.4	19.4	332.0	258.3	16.8	389.3	19.8	16.7	388.8	19.4	227.4	23.1	148.5	90.9	2.9	226.9	23.0	148.5	90.9	2.9				
40	37.50	2.2	5.0	333.6	247.9	17.9	394.7	18.6	17.7	394.2	18.8	250.0	23.5	169.7	92.7	3.1	249.4	23.4	169.7	92.7	3.1				
	56.25	4.9	11.3	335.6	251.4	17.3	394.6	19.4	17.1	394.1	19.5	262.1	23.8	181.0	93.7	3.2	261.5	23.6	181.0	93.7	3.2				
	75.00	7.6	17.6	335.7	253.5	17.1	393.9	19.6	16.9	393.4	19.9	268.8	23.9	187.2	94.6	3.3	268.2	23.7	187.2	94.6	3.3				
50	37.50	2.0	4.6	327.1	242.7	19.1	392.4	17.1	19.0	391.9	16.3	287.7	24.3	204.8	96.2	3.5	287.2	24.1	204.8	96.2	3.5				
	56.25	4.5	10.4	332.1	246.4	18.2	394.3	18.2	18.1	393.8	17.6	302.5	24.6	218.5	97.2	3.6	302.0	24.5	218.5	97.2	3.6				
	75.00	7.0	16.2	333.9	248.1	17.8	394.7	18.8	17.7	394.2	18.8	310.7	24.8	226.1	98.3	3.7	310.2	24.6	226.1	98.3	3.7				
60	37.50	1.9	4.3	317.0	237.5	20.8	388.0	15.2	20.6	387.5	16.3	325.9	25.2	240.1	99.7	3.8	325.4	25.0	240.1	99.7	3.8				
	56.25	4.2	9.8	324.3	241.3	19.6	391.3	16.5	19.5	390.7	16.8	343.4	25.6	256.2	101.0	3.9	342.9	25.4	256.2	101.0	3.9				
	75.00	6.6	15.2	327.5	243.0	19.1	392.6	17.1	18.9	392.0	17.2	353.1	25.8	265.1	102.3	4.0	352.6	25.7	265.1	102.3	4.0				
70	37.50	1.8	4.1	304.3	232.2	22.8	382.1	13.3	22.6	381.6	13.3	364.5	26.1	275.5	103.2	4.1	364.0	25.9	275.5	103.2	4.1				
	56.25	4.0	9.3	313.3	235.9	21.4	386.3	14.6	21.2	385.8	14.3	384.7	26.6	294.1	104.8	4.2	384.2	26.4	294.1	104.8	4.2				
	75.00	6.3	14.5	317.4	237.7	20.7	388.2	15.3	20.6	387.6	15.4	396.0	26.8	304.4	106.4	4.3	395.5	26.7	304.4	106.4	4.3				
80	37.50	1.7	4.0	289.9	226.1	25.1	375.4	11.5	24.9	374.9	12.8	403.3	27.0	311.1	106.7	4.4	402.8	26.9	311.1	106.7	4.4				
	56.25	3.9	9.0	299.8	230.2	23.5	380.0	12.8	23.3	379.5	13.8	426.3	27.6	332.2	108.4	4.5	425.8	27.4	332.2	108.4	4.5				
	75.00	6.1	14.0	304.6	232.1	22.8	382.2	13.4	22.6	381.7	14.8	439.1	27.9	344.0	110.1	4.6	438.6	27.7	344.0	110.1	4.6				
90	37.50	1.7	3.9	274.3	219.7	27.6	368.4	9.9	27.4	367.9	12.2	442.3	28.0	347.0	110.3	4.6	441.8	27.8	347.0	110.3	4.6				
	56.25	3.8	8.8	284.7	224.0	25.9	373.0	11.0	25.7	372.5	13.2	468.1	28.5	370.8	112.1	4.8	467.6	28.4	370.8	112.1	4.8				
	75.00	5.9	13.7	289.8	226.1	25.1	375.4	11.5	24.9	374.9	14.2	482.4	28.9	384.0	113.9	4.9	481.9	28.7	384.0	113.9	4.9				
100	37.50	1.7	3.8	258.4	212.9	30.3	361.9	8.5	30.2	361.3	8.5	Operation Not Recommended													
	56.25	3.7	8.6	268.7	217.4	28.5	366.1	9.4	28.4	365.5	9.2														
	75.00	5.8	13.4	274.0	219.7	27.6	368.3	9.9	27.5	367.8	9.9														
110	37.50	1.6	3.7	242.8	205.7	33.2	356.3	7.3	33.1	355.7	8.2														
	56.25	3.6	8.4	252.7	210.2	31.4	359.7	8.0	31.2	359.2	8.8														
	75.00	5.7	13.1	257.8	212.7	30.4	361.6	8.5	30.3	361.1	9.6														
120	37.50	1.5	3.5	228.5	198.5	36.3	352.3	6.3	36.1	351.8	6.3														
	56.25	3.5	8.1	237.3	202.9	34.4	354.6	6.9	34.2	354.0	6.8														
	75.00	5.5	12.7	242.1	205.3	33.4	356.0	7.2	33.2	355.5	7.3														

Notes:

- Interpolation is permissible, extrapolation is not.
- All entering air conditions are 80°F (26.6°C) DB and 67°F (19.4°C) WB in cooling, and 70°F (21°C) DB in heating.
- AHRI/ISO certified conditions are 80.6°F (27°C) DB and 66.2°F (19°C) WB in cooling and 68°F (20°C) DB in heating.
- Table does not reflect fan or pump power corrections for AHRI/ISO conditions.
- All performance data is based on the lower voltage of dual voltage units.
- Performance stated is at the rated power supply; performance may vary as the power supply varies from the rated.
- Operation below 40°F EWT is based on a 15% methanol antifreeze solution.
- Operation below 60°F EWT requires optional insulated water/refrigerant circuit.
- See performance correction tables for operating conditions other than those listed above.
- See Performance Data Selection Notes for operation in the shaded areas.

Performance Data MB300 Vertical Part Load (VFD)

Models:
MB
072-300

5,000 CFM Rated Airflow

EWT °F	WPD			Cooling - EAT 80/67°F					Heating - EAT 70°F				
	FLOW GPM	PSI	FT	TC	SC	VFD			VFD				
						Power kW	HR	EER	HC	Power kW	HE	LAT	COP
20	Operation Not Recommended												
30	18.75	2.0	4.6	170.5	126.8	6.51	192.7	26.2	106.0	10.04	71.7	87.6	3.1
	28.13	4.3	10.0	172.2	127.5	6.13	193.1	28.1	108.2	10.10	73.8	88.0	3.1
	37.50	6.7	15.4	172.9	127.7	5.96	193.2	29.0	118.3	10.34	83.0	89.9	3.4
40	18.75	1.8	4.2	167.4	125.0	7.17	191.8	23.3	123.7	10.47	87.9	90.8	3.5
	28.13	4.0	9.2	169.6	126.3	6.71	192.5	25.3	126.6	10.54	90.7	91.4	3.5
	37.50	6.1	14.2	170.6	126.8	6.50	192.7	26.3	135.8	10.76	99.1	93.1	3.7
50	18.75	1.7	3.8	163.5	122.6	7.94	190.6	20.6	142.6	10.92	105.3	94.3	3.8
	28.13	3.7	8.5	166.2	124.3	7.41	191.5	22.4	146.3	11.02	108.8	95.0	3.9
	37.50	5.7	13.2	167.5	125.0	7.15	191.9	23.4	154.1	11.21	115.9	96.5	4.0
60	18.75	1.6	3.6	158.9	119.8	8.83	189.0	18.0	162.3	11.40	123.4	98.0	4.2
	28.13	3.5	8.0	162.1	121.8	8.22	190.1	19.7	166.9	11.51	127.6	98.8	4.2
	37.50	5.4	12.4	163.6	122.7	7.93	190.6	20.6	173.0	11.66	133.2	100.0	4.3
70	18.75	1.5	3.4	153.5	116.8	9.82	187.1	15.6	182.6	11.89	142.0	101.7	4.5
	28.13	3.3	7.6	157.2	118.9	9.14	188.4	17.2	187.9	12.01	146.9	102.7	4.6
	37.50	5.1	11.7	158.9	119.9	8.82	189.0	18.0	192.0	12.11	150.7	103.5	4.6
80	18.75	1.4	3.3	147.5	113.7	10.93	184.8	13.5	202.9	12.36	160.7	105.5	4.8
	28.13	3.2	7.3	151.6	115.8	10.18	186.3	14.9	208.9	12.50	166.2	106.6	4.9
	37.50	4.9	11.3	153.5	116.8	9.83	187.1	15.6	211.0	12.55	168.2	107.0	4.9
90	18.75	1.4	3.2	140.7	110.5	12.15	182.1	11.6	222.9	12.82	179.2	109.2	5.1
	28.13	3.1	7.1	145.2	112.6	11.34	183.9	12.8	229.4	12.96	185.2	110.4	5.2
	37.50	4.7	10.9	147.4	113.6	10.95	184.7	13.5	223.5	13.00	180.8	110.6	5.2
100	18.75	1.4	3.2	133.1	107.3	13.48	179.1	9.9	Operation Not Recommended				
	28.13	3.0	6.9	138.1	109.4	12.61	181.1	10.9					
	37.50	4.6	10.6	140.4	110.4	12.19	182.0	11.5					
110	18.75	1.3	3.0	124.9	104.1	14.92	175.8	8.4					
	28.13	2.9	6.7	130.2	106.2	14.00	177.9	9.3					
	37.50	4.5	10.4	132.8	107.2	13.54	179.0	9.8					
120	18.75	1.2	2.9	115.9	100.8	16.47	172.1	7.0					
	28.13	2.8	6.5	121.6	102.9	15.49	174.4	7.8					
	37.50	4.4	10.1	124.3	103.9	15.01	175.6	8.3					

Notes:

- Interpolation is permissible, extrapolation is not.
- All entering air conditions are 80°F (26.6°C) DB and 67°F (19.4°C) WB in cooling, and 70°F (21°C) DB in heating.
- AHRI/ISO certified conditions are 80.6°F (27°C) DB and 66.2°F (19°C) WB in cooling and 68°F (20°C) DB in heating.
- Table does not reflect fan or pump power corrections for AHRI/ISO conditions.
- All performance data is based on the lower voltage of dual voltage units.
- Performance stated is at the rated power supply; performance may vary as the power supply varies from the rated.
- Operation below 40°F EWT is based on a 15% methanol antifreeze solution.
- Operation below 60°F EWT requires optional insulated water/refrigerant circuit.
- See performance correction tables for operating conditions other than those listed above.
- See Performance Data Selection Notes for operation in the shaded areas.

Corrections Airflow, Cooling, and Heating Tables

Models:
MB
072-300

Airflow Corrections

Percent of Rated Airflow	Total Capacity	Sensible	Power	Heat of Rejection	Heating Capacity	Power	Heat of Extraction
75%	0.962	0.869	0.947	0.959	0.959	1.039	0.962
81%	0.975	0.902	0.960	0.972	0.970	1.024	0.973
88%	0.988	0.934	0.972	0.984	0.981	1.009	0.985
94%	0.994	0.967	0.986	0.992	0.990	1.004	0.992
100%	1.000	1.000	1.000	1.000	1.000	1.000	1.000
106%	1.007	1.028	1.014	1.009	1.010	1.000	1.005
113%	1.014	1.056	1.028	1.017	1.020	1.001	1.010
119%	1.019	1.083	1.046	1.024	1.036	1.008	1.013
125%	1.023	1.109	1.063	1.031	1.051	1.015	1.016

Cooling Corrections

Entering Air WB°F	Total Capacity	Sensible Cooling Capacity Multiplier - Entering DB °F									Power	Heat of Rejection
		60	65	70	75	80	80.6	85	90	95		
50	0.7335	0.8825	*	*	*	*	*	*	*	*	0.9782	0.7834
55	0.8063	0.6757	0.8842	1.1119	*	*	*	*	*	*	0.9836	0.8424
60	0.8830		0.6734	0.8817	1.0918	*	*	*	*	*	0.9900	0.9301
65	0.9774			0.6682	0.8764	1.0885	1.1136	1.2949	*	*	0.9973	0.9981
66.2	0.9851			0.6177	0.8243	1.0357	1.0612	1.2452	*	*	0.9987	0.9879
67	1.0000			0.5842	0.7897	1.0000	1.0262	1.2119	*	*	1.0000	1.0000
70	1.0426				0.6609	0.8688	0.8941	1.0811	1.2916	*	1.0043	1.0420
75	1.1386					0.6517	0.6517	0.8594	1.0695	1.2838	1.0118	1.1128

- * = Sensible capacity equals total capacity.
- AHRI/ISO/ASHRAE 13256-1 uses entering air conditions of Cooling - 80.6°F DB/66.2°F WB, 1 and Heating - 68°F DB/59°F WB entering air temperature

Heating Corrections

Entering Air DB °F	Heating Capacity	Power	Heat of Extraction
50	1.040	0.839	1.101
55	1.030	0.883	1.075
60	1.018	0.920	1.053
65	1.008	0.960	1.026
68	1.001	0.984	1.011
70	1.000	1.000	1.000
75	0.978	1.038	0.979
80	0.968	1.091	0.943

Wet Coil to Dry Coil Conversion Table

Required BHP Multiplier	Required RPM Multiplier	Air Coil Face Velocity
1.00	1.00	240
1.00	1.00	305
0.99	1.00	370
0.99	1.00	435
0.98	1.00	500
0.98	1.00	565

Corrections Antifreeze Tables

Models:
MB
072-300

EWT (°F)	Antifreeze Type	Antifreeze %	Cooling			Heating		WPD
			Total Cap	Sensible Cap	Watts	Total Cap	Watts	
90	Water	0%	1.000	1.000	1.000	1.000	1.000	1.000
	Ethanol	5%	0.998	0.998	1.002	0.996	0.999	1.025
		10%	0.996	0.996	1.003	0.991	0.997	1.048
		15%	0.994	0.994	1.005	0.987	0.996	1.098
		20%	0.991	0.991	1.006	0.982	0.994	1.142
		25%	0.986	0.986	1.009	0.972	0.991	1.207
		30%	0.981	0.981	1.012	0.962	0.988	1.265
		35%	0.977	0.977	1.015	0.953	0.985	1.312
		40%	0.972	0.972	1.018	0.943	0.982	1.370
		45%	0.966	0.966	1.023	0.931	0.978	1.431
		50%	0.959	0.959	1.027	0.918	0.974	1.494
	Ethylene Glycol	5%	0.998	0.998	1.002	0.996	0.999	1.021
		10%	0.996	0.996	1.003	0.991	0.997	1.040
		15%	0.994	0.994	1.004	0.987	0.996	1.079
		20%	0.991	0.991	1.005	0.982	0.995	1.114
		25%	0.988	0.988	1.008	0.976	0.993	1.146
		30%	0.985	0.985	1.010	0.969	0.990	1.175
		35%	0.982	0.982	1.012	0.963	0.988	1.208
		40%	0.979	0.979	1.014	0.956	0.986	1.243
		45%	0.976	0.976	1.016	0.950	0.984	1.278
		50%	0.972	0.972	1.018	0.943	0.982	1.314
	Methanol	5%	0.997	0.997	1.002	0.993	0.998	1.039
		10%	0.993	0.993	1.004	0.986	0.996	1.075
		15%	0.990	0.990	1.007	0.979	0.994	1.116
		20%	0.986	0.986	1.009	0.972	0.991	1.154
		25%	0.982	0.982	1.012	0.964	0.989	1.189
		30%	0.978	0.978	1.014	0.955	0.986	1.221
		35%	0.974	0.974	1.017	0.947	0.984	1.267
		40%	0.970	0.970	1.020	0.939	0.981	1.310
		45%	0.966	0.966	1.023	0.930	0.978	1.353
		50%	0.961	0.961	1.026	0.920	0.975	1.398
	Propylene Glycol	5%	0.995	0.995	1.003	0.990	0.997	1.065
		10%	0.990	0.990	1.006	0.980	0.994	1.119
		15%	0.986	0.986	1.009	0.971	0.991	1.152
		20%	0.981	0.981	1.012	0.962	0.988	1.182
		25%	0.978	0.978	1.014	0.956	0.986	1.227
		30%	0.975	0.975	1.016	0.950	0.984	1.267
		35%	0.972	0.972	1.018	0.944	0.982	1.312
		40%	0.969	0.969	1.020	0.938	0.980	1.356
		45%	0.965	0.965	1.023	0.929	0.977	1.402
		50%	0.960	0.960	1.026	0.919	0.974	1.450

Table continued on next page

Corrections Antifreeze Tables

Models:
MB
072-300

Table continued from previous page

EWT (°F)	Antifreeze Type	Antifreeze %	Cooling			Heating		WPD
			Total Cap	Sensible Cap	Watts	Total Cap	Watts	
30	Water	0%	1.000	1.000	1.000	1.000	1.000	1.000
	Ethanol	5%	0.991	0.991	1.006	0.981	0.994	1.140
		10%	0.981	0.981	1.012	0.961	0.988	1.242
		15%	0.973	0.973	1.018	0.944	0.983	1.295
		20%	0.964	0.964	1.024	0.927	0.977	1.343
		25%	0.959	0.959	1.028	0.917	0.974	1.363
		30%	0.954	0.954	1.031	0.907	0.970	1.383
		35%	0.949	0.949	1.035	0.897	0.967	1.468
		40%	0.944	0.944	1.038	0.887	0.964	1.523
		45%	0.940	0.940	1.041	0.880	0.962	1.580
		50%	0.936	0.936	1.043	0.872	0.959	1.639
	Ethylene Glycol	5%	0.997	0.997	1.002	0.993	0.998	1.040
		10%	0.993	0.993	1.004	0.986	0.996	1.075
		15%	0.990	0.990	1.006	0.980	0.994	1.122
		20%	0.987	0.987	1.008	0.973	0.992	1.163
		25%	0.983	0.983	1.011	0.966	0.990	1.195
		30%	0.979	0.979	1.013	0.958	0.987	1.225
		35%	0.976	0.976	1.016	0.951	0.985	1.279
		40%	0.972	0.972	1.018	0.943	0.982	1.324
		45%	0.969	0.969	1.021	0.937	0.980	1.371
		50%	0.966	0.966	1.023	0.930	0.978	1.419
	Methanol	5%	0.995	0.995	1.004	0.989	0.997	1.069
		10%	0.989	0.989	1.007	0.978	0.993	1.127
		15%	0.984	0.984	1.011	0.968	0.990	1.164
		20%	0.979	0.979	1.014	0.957	0.986	1.197
		25%	0.975	0.975	1.017	0.949	0.984	1.216
		30%	0.971	0.971	1.019	0.941	0.981	1.235
		35%	0.967	0.967	1.022	0.933	0.979	1.286
		40%	0.963	0.963	1.025	0.924	0.976	1.323
		45%	0.959	0.959	1.028	0.917	0.974	1.360
		50%	0.955	0.955	1.030	0.910	0.971	1.399
	Propylene Glycol	5%	0.995	0.995	1.004	0.989	0.997	1.071
		10%	0.989	0.989	1.007	0.978	0.993	1.130
		15%	0.985	0.985	1.010	0.968	0.990	1.206
		20%	0.980	0.980	1.013	0.958	0.987	1.270
		25%	0.974	0.974	1.017	0.947	0.983	1.359
		30%	0.968	0.968	1.021	0.935	0.979	1.433
		35%	0.963	0.963	1.025	0.924	0.976	1.522
		40%	0.957	0.957	1.029	0.913	0.972	1.614
		45%	0.949	0.949	1.034	0.898	0.967	1.712
		50%	0.941	0.941	1.039	0.882	0.962	1.816

Corrections Motorized Water Valve and Modulating Valve Adders

Models:
MB
072-300

Motorized Water Valve and Modulating Valve Adders

Size	Flow	MWV					MOD Valve				
		C _v	Close Off Pressure	MOPD	Pressure Drop		C _v	Close Off Pressure	MOPD	Pressure Drop	
					PSI	FT				PSI	FT
072	9.00	37	200	50	0.06	0.1	10	200	50	0.81	1.9
	13.50				0.13	0.3				1.82	4.2
	18.00				0.24	0.5				3.24	7.5
096	12.00	37	200	50	0.11	0.2	10	200	50	1.44	3.3
	18.00				0.24	0.5				3.24	7.5
	24.00				0.42	1.0				5.76	13.3
120	15.00	37	200	150	0.16	0.4	19	200	50	0.62	1.4
	22.50				0.37	0.9				1.40	3.2
	30.00				0.66	1.5				2.49	5.8
168	21.00	37	200	150	0.32	0.7	29	200	50	0.52	1.2
	31.50				0.72	1.7				1.18	2.7
	42.00				1.29	3.0				2.10	4.8
192	24.00	37	200	150	0.42	1.0	29	200	50	0.68	1.6
	36.00				0.95	2.2				1.54	3.6
	48.00				1.68	3.9				2.74	6.3
240	30.00	37	200	150	0.66	1.5	29	200	50	1.07	2.5
	45.00				1.48	3.4				2.41	5.6
	60.00				2.63	6.1				4.28	9.9
300	37.50	57	200	150	0.43	1.0	29	200	50	1.67	3.9
	56.25				0.97	2.2				3.76	8.7
	75.00				1.73	4.0				6.69	15.4

PSI values are calculated based on manufacturer-recommended 70°F entering water temperature.

Blower Performance MB*072

Models:
MB
072-300

SCFM	ESP (in.w.c.)	0.00	0.10	0.20	0.30	0.40	0.50	0.60	0.70	0.80	0.90	1.00	1.10	1.20	1.30	1.40	1.50
1,800	BHP			0.28	0.32	0.35	0.39	0.42	0.45	0.48	0.52	0.56	0.60	0.64	0.69	0.72	0.76
	Sheave/Mtr			B	B	B	A	A	A	A	A	A	C	C	C	C	C
	RPM			599	645	690	735	775	815	850	885	910	940	965	995	1015	1040
1,900	BHP			0.31	0.36	0.40	0.44	0.49	0.53	0.58	0.62	0.65	0.69	0.73	0.76	0.80	0.84
	Sheave/Mtr			B	B	A	A	A	A	A	A	C	C	C	C	C	C
	RPM			604	655	695	740	780	820	855	890	920	950	980	1005	1030	1055
2,000	BHP		0.31	0.34	0.39	0.45	0.50	0.54	0.59	0.63	0.67	0.72	0.75	0.79	0.82	0.86	0.90
	Sheave/Mtr		B	B	B	A	A	A	A	A	A	C	C	C	C	C	C
	RPM		568	615	660	705	750	785	825	860	895	930	960	990	1015	1040	1065
2,100	BHP	0.33	0.38	0.42	0.46	0.50	0.54	0.59	0.65	0.70	0.74	0.78	0.81	0.85	0.89	0.94	0.98
	Sheave/Mtr	B	B	B	A	A	A	A	A	A	A	C	C	C	C	C	C
	RPM	531	583	630	670	715	755	795	835	875	905	940	970	1000	1025	1055	1080
2,200	BHP	0.37	0.40	0.45	0.49	0.55	0.60	0.65	0.70	0.75	0.79	0.83	0.87	0.92	0.96	1.00	1.04
	Sheave/Mtr	B	B	B	A	A	A	A	A	A	C	C	C	C	C	E	E
	RPM	552	599	645	685	730	770	810	850	885	915	950	980	1010	1040	1065	1090
2,300	BHP	0.42	0.47	0.51	0.56	0.60	0.65	0.70	0.75	0.80	0.84	0.89	0.94	1.00	1.05	1.10	1.16
	Sheave/Mtr	B	B	B	A	A	A	A	A	A	C	C	C	E	E	E	E
	RPM	573	620	660	705	745	785	820	860	895	925	960	990	1020	1050	1075	1105
2,400	BHP	0.48	0.52	0.57	0.61	0.66	0.72	0.78	0.83	0.87	0.92	0.97	1.02	1.07	1.13	1.19	1.25
	Sheave/Mtr	B	B	A	A	A	A	A	A	A	C	C	E	E	E	E	E
	RPM	604	645	690	730	765	805	845	880	910	945	975	1010	1035	1065	1095	1125
2,500	BHP	0.52	0.57	0.61	0.66	0.72	0.78	0.83	0.89	0.94	1.00	1.03	1.08	1.14	1.20	1.25	1.31
	Sheave/Mtr	B	B	A	A	A	A	A	A	C	E	E	E	E	E	E	E
	RPM	620	660	700	740	780	815	850	885	920	950	985	1015	1045	1075	1100	1130
2,600	BHP	0.56	0.61	0.66	0.70	0.76	0.82	0.88	0.93	0.98	1.04	1.08	1.14	1.20	1.26	1.32	1.37
	Sheave/Mtr	B	A	A	A	A	A	A	A	C	E	E	E	E	E	E	E
	RPM	635	675	715	750	790	825	860	895	925	960	990	1020	1050	1080	1110	1135
2,700	BHP	0.61	0.66	0.71	0.76	0.82	0.87	0.93	0.98	1.04	1.10	1.15	1.21	1.27	1.33	1.39	1.45
	Sheave/Mtr	B	A	A	A	A	A	A	A	E	E	E	E	E	E	E	E
	RPM	655	695	730	770	805	840	875	905	940	970	1000	1030	1060	1090	1120	1145
2,800	BHP	0.66	0.72	0.77	0.83	0.88	0.93	0.99	1.05	1.11	1.16	1.22	1.30	1.37	1.44	1.51	1.57
	Sheave/Mtr	B	A	A	A	A	A	A	D	E	E	E	E	E	E	E	E
	RPM	670	710	750	785	815	850	885	915	950	980	1010	1040	1070	1100	1130	1155
2,900	BHP	0.71	0.77	0.82	0.87	0.93	0.98	1.04	1.10	1.16	1.22	1.30	1.36	1.43	1.50	1.57	1.63
	Sheave/Mtr	A	A	A	A	A	A	D	E	E	E	E	E	E	E	E	E
	RPM	685	725	765	795	830	860	895	925	955	985	1020	1045	1075	1105	1135	1160
3,000	BHP	0.79	0.84	0.90	0.95	1.01	1.07	1.13	1.19	1.25	1.31	1.38	1.46	1.52	1.59	1.66	
	Sheave/Mtr	A	A	A	A	A	D	D	E	E	E	E	E	E	E	E	
	RPM	710	745	780	815	850	885	915	945	975	1005	1035	1065	1090	1120	1150	

- Notes:
- A, 1 = Standard RPM/Standard Blower Motor
 - E, 5 = High RPM/Large Blower Motor
 - The maximum allowable altitude of installation for this product is 6,561 ft (2,000 m).

Blower Performance MB*072 with VFD

Models:
MB
072-300

SCFM	ESP (in.w.c.)	0.00	0.10	0.20	0.30	0.40	0.50	0.60	0.70	0.80	0.90	1.00	1.10	1.20	1.30	1.40	1.50
1,800	BHP			0.28	0.32	0.35	0.39	0.42	0.45	0.48	0.52	0.56	0.60	0.64	0.69	0.72	0.76
	Discrete Spd Setting			B	B	B	A	A	A	A	A	A	C	C	C	C	C
	RPM			599	645	690	735	775	815	850	885	910	940	965	995	1015	1040
1,900	BHP			0.31	0.36	0.40	0.44	0.49	0.53	0.58	0.62	0.65	0.69	0.73	0.76	0.80	0.84
	Discrete Spd Setting			B	B	A	A	A	A	A	A	C	C	C	C	C	C
	RPM			604	655	695	740	780	820	855	890	920	950	980	1005	1030	1055
2,000	BHP		0.31	0.34	0.39	0.45	0.50	0.54	0.59	0.63	0.67	0.72	0.75	0.79	0.82	0.86	0.90
	Discrete Spd Setting		B	B	B	A	A	A	A	A	A	C	C	C	C	C	C
	RPM		568	615	660	705	750	785	825	860	895	930	960	990	1015	1040	1065
2,100	BHP	0.33	0.38	0.42	0.46	0.50	0.54	0.59	0.65	0.70	0.74	0.78	0.81	0.85	0.89	0.94	0.98
	Discrete Spd Setting	B	B	B	A	A	A	A	A	A	A	C	C	C	C	C	C
	RPM	531	583	630	670	715	755	795	835	875	905	940	970	1000	1025	1055	1080
2,200	BHP	0.37	0.40	0.45	0.49	0.55	0.60	0.65	0.70	0.75	0.79	0.83	0.87	0.92	0.96	1.00	1.04
	Discrete Spd Setting	B	B	B	A	A	A	A	A	A	C	C	C	C	C	E	E
	RPM	552	599	645	685	730	770	810	850	885	915	950	980	1010	1040	1065	1090
2,300	BHP	0.42	0.47	0.51	0.56	0.60	0.65	0.70	0.75	0.80	0.84	0.89	0.94	1.00	1.05	1.10	1.16
	Discrete Spd Setting	B	B	B	A	A	A	A	A	A	C	C	C	C	C	C	C
	RPM	573	620	660	705	745	785	820	860	895	925	960	990	1020	1050	1075	1105
2,400	BHP	0.48	0.52	0.57	0.61	0.66	0.72	0.78	0.83	0.87	0.92	0.97	1.02	1.07	1.13	1.19	1.25
	Discrete Spd Setting	B	B	A	A	A	A	A	A	A	C	C	C	C	C	C	C
	RPM	604	645	690	730	765	805	845	880	910	945	975	1010	1035	1065	1095	1125
2,500	BHP	0.52	0.57	0.61	0.66	0.72	0.78	0.83	0.89	0.94	1.00	1.03	1.08	1.14	1.20	1.25	1.31
	Discrete Spd Setting	B	B	A	A	A	A	A	A	C	C	C	C	C	C	C	C
	RPM	620	660	700	740	780	815	850	885	920	950	985	1015	1045	1075	1100	1130
2,600	BHP	0.56	0.61	0.66	0.70	0.76	0.82	0.88	0.93	0.98	1.04	1.08	1.14	1.20	1.26	1.32	1.37
	Discrete Spd Setting	B	A	A	A	A	A	A	A	C	C	C	C	C	C	C	C
	RPM	635	675	715	750	790	825	860	895	925	960	990	1020	1050	1080	1110	1135
2,700	BHP	0.61	0.66	0.71	0.76	0.82	0.87	0.93	0.98	1.04	1.10	1.15	1.21	1.27	1.33	1.39	1.45
	Discrete Spd Setting	B	A	A	A	A	A	A	A	C	C	C	C	C	C	C	C
	RPM	655	695	730	770	805	840	875	905	940	970	1000	1030	1060	1090	1120	1145
2,800	BHP	0.66	0.72	0.77	0.83	0.88	0.93	0.99	1.05	1.11	1.16	1.22	1.30	1.37	1.44	1.51	1.57
	Discrete Spd Setting	B	A	A	A	A	A	A	A	C	C	C	C	C	C	C	C
	RPM	670	710	750	785	815	850	885	915	950	980	1010	1040	1070	1100	1130	1155
2,900	BHP	0.71	0.77	0.82	0.87	0.93	0.98	1.04	1.10	1.16	1.22	1.30	1.36	1.43	1.50	1.57	
	Discrete Spd Setting	A	A	A	A	A	A	A	C	C	C	C	C	C	C	C	
	RPM	685	725	765	795	830	860	895	925	955	985	1020	1045	1075	1105	1135	
3,000	BHP	0.79	0.84	0.90	0.95	1.01	1.07	1.13	1.19	1.25	1.31	1.38	1.46	1.52	1.59		
	Discrete Spd Setting	A	A	A	A	A	A	A	C	C	C	C	C	C	C		
	RPM	710	745	780	815	850	885	915	945	975	1005	1035	1065	1090	1120		

Notes:

- Motor Sheave set to 1-turn open from factory.
- Factory torque setting is A. Torque setting is field-adjustable to any torque setting listed in drive table through the Wireless Service Tool.
- The unit can control the blower through LAT control. Enable this setting in the field with the Wireless Service Tool.
- The maximum allowable altitude of installation for this product is 6,561 ft (2,000 m).

Blower Performance MB*096

Models:
MB
072-300

SCFM	ESP (in.w.c.)	0.00	0.10	0.20	0.30	0.40	0.50	0.60	0.70	0.80	0.90	1.00	1.10	1.20	1.30	1.40	1.50
2,400	BHP	0.45	0.50	0.54	0.59	0.63	0.69	0.74	0.80	0.85	0.90	0.94	0.99	1.04	1.10	1.16	1.22
	Sheave/Mtr	B	B	B	B	B	A	A	A	A	A	A	A	A	A	C	C
	RPM	578	625	665	705	745	785	820	860	895	925	960	990	1020	1050	1080	1110
2,500	BHP	0.50	0.55	0.59	0.64	0.69	0.75	0.81	0.88	0.92	0.97	1.01	1.06	1.12	1.17	1.23	1.29
	Sheave/Mtr	B	B	B	B	A	A	A	A	A	A	A	A	A	C	C	C
	RPM	599	645	685	725	765	800	835	875	905	940	970	1005	1035	1060	1090	1120
2,600	BHP	0.55	0.60	0.65	0.69	0.75	0.80	0.86	0.92	0.97	1.02	1.08	1.13	1.19	1.25	1.30	1.36
	Sheave/Mtr	B	B	B	B	A	A	A	A	A	A	A	A	A	C	C	C
	RPM	625	665	705	740	780	815	850	885	920	950	985	1015	1045	1075	1100	1130
2,700	BHP	0.60	0.65	0.70	0.75	0.80	0.86	0.91	0.97	1.02	1.08	1.14	1.20	1.26	1.32	1.38	1.44
	Sheave/Mtr	B	B	B	A	A	A	A	A	A	A	A	A	C	C	C	C
	RPM	645	685	725	760	795	830	865	900	930	960	995	1025	1055	1085	1115	1140
2,800	BHP	0.65	0.71	0.76	0.82	0.87	0.93	0.98	1.04	1.10	1.16	1.21	1.28	1.36	1.43	1.50	1.56
	Sheave/Mtr	B	B	B	A	A	A	A	A	A	A	A	A	C	C	C	C
	RPM	665	705	745	780	810	845	880	910	945	975	1005	1035	1065	1095	1125	1150
2,900	BHP	0.71	0.76	0.82	0.87	0.92	0.98	1.03	1.09	1.16	1.22	1.29	1.36	1.43	1.50	1.57	1.63
	Sheave/Mtr	B	B	A	A	A	A	A	A	A	A	A	A	C	C	C	C
	RPM	685	720	760	795	825	860	890	920	955	985	1015	1045	1075	1105	1135	1160
3,000	BHP	0.78	0.84	0.89	0.95	1.00	1.06	1.12	1.18	1.24	1.30	1.37	1.43	1.50	1.58	1.64	1.71
	Sheave/Mtr	B	B	A	A	A	A	A	A	A	A	A	C	C	C	C	C
	RPM	700	740	775	810	845	880	910	940	970	1000	1030	1055	1085	1115	1140	1170
3,100	BHP	0.85	0.91	0.96	1.02	1.08	1.14	1.22	1.29	1.36	1.44	1.50	1.57	1.63	1.70	1.76	1.82
	Sheave/Mtr	B	B	A	A	A	A	A	A	A	A	A	C	C	C	C	C
	RPM	720	755	790	825	860	890	925	955	985	1015	1040	1070	1095	1125	1150	1175
3,200	BHP	0.93	1.00	1.07	1.14	1.20	1.26	1.32	1.38	1.44	1.51	1.57	1.64	1.70	1.78	1.85	1.92
	Sheave/Mtr	B	A	A	A	A	A	A	A	A	A	C	C	C	C	C	C
	RPM	740	775	810	845	875	905	935	965	995	1025	1050	1080	1105	1135	1160	1185
3,300	BHP	1.01	1.08	1.14	1.21	1.28	1.33	1.39	1.45	1.51	1.58	1.64	1.72	1.78	1.84	1.93	2.00
	Sheave/Mtr	B	A	A	A	A	A	A	A	A	A	C	C	C	C	C	E
	RPM	755	790	820	855	890	915	945	975	1005	1035	1060	1090	1115	1140	1170	1195
3,400	BHP	1.08	1.15	1.22	1.29	1.35	1.41	1.47	1.53	1.59	1.68	1.75	1.83	1.90	1.96	2.02	2.08
	Sheave/Mtr	A	A	A	A	A	A	A	A	A	A	C	C	C	C	E	E
	RPM	765	800	835	870	900	930	960	990	1015	1045	1070	1100	1125	1150	1175	1200

Notes:

- A, 1 = Standard RPM/Standard Blower Motor
- E, 5 = High RPM/Large Blower Motor
- The maximum allowable altitude of installation for this product is 6,561 ft (2,000 m).

Table continued on next page.

Blower Performance MB*096

Models:
MB
072-300

Table continued from previous page

SCFM	ESP (in.w.c.)	0.00	0.10	0.20	0.30	0.40	0.50	0.60	0.70	0.80	0.90	1.00	1.10	1.20	1.30	1.40	1.50
3,500	BHP	1.16	1.23	1.29	1.36	1.42	1.48	1.54	1.60	1.66	1.73	1.79	1.85	1.92	2.01	2.09	2.17
	Sheave/Mtr	A	A	A	A	A	A	A	A	A	C	C	C	C	E	E	E
	RPM	780	815	845	880	910	940	970	1000	1025	1055	1080	1105	1130	1160	1185	1210
3,600	BHP	1.24	1.30	1.37	1.44	1.51	1.58	1.65	1.72	1.78	1.86	1.92	1.98	2.06	2.13	2.21	2.29
	Sheave/Mtr	A	A	A	A	A	A	A	A	A	C	C	C	E	E	E	E
	RPM	795	825	860	890	920	950	980	1010	1035	1065	1090	1115	1145	1165	1190	1215
3,700	BHP	1.34	1.40	1.46	1.53	1.61	1.68	1.75	1.82	1.90	1.97	2.06	2.13	2.21	2.28	2.36	2.44
	Sheave/Mtr	A	A	A	A	A	A	A	A	C	C	E	E	E	E	E	E
	RPM	820	850	880	910	940	970	1000	1025	1055	1080	1110	1135	1160	1180	1205	1230
3,800	BHP	1.43	1.49	1.56	1.63	1.70	1.78	1.86	1.94	2.02	2.12	2.20	2.28	2.34	2.42	2.50	2.58
	Sheave/Mtr	A	A	A	A	A	A	A	A	E	E	E	E	E	E	E	E
	RPM	840	870	900	930	960	990	1020	1045	1070	1100	1125	1150	1170	1195	1220	1245
3,900	BHP	1.58	1.64	1.71	1.78	1.85	1.93	2.01	2.09	2.19	2.27	2.35	2.41	2.49	2.57	2.65	
	Sheave/Mtr	A	A	A	A	A	A	D	D	E	E	E	E	E	E	E	
	RPM	865	890	920	950	980	1010	1035	1060	1090	1115	1140	1160	1185	1210	1235	
4,000	BHP	1.68	1.75	1.83	1.92	2.00	2.08	2.16	2.26	2.34	2.42	2.50	2.56	2.64	2.72	2.80	
	Sheave/Mtr	A	A	A	A	D	D	D	E	E	E	E	E	E	E	E	
	RPM	885	910	940	970	1000	1025	1050	1080	1105	1130	1155	1175	1200	1225	1250	

Notes:

- A, 1 = Standard RPM/Standard Blower Motor
- E, 5 = High RPM/Large Blower Motor
- The maximum allowable altitude of installation for this product is 6,561 ft (2,000 m).

Blower Performance MB*096 with VFD

Models:
MB
072-300

SCFM	ESP (in.w.c.)	0.00	0.10	0.20	0.30	0.40	0.50	0.60	0.70	0.80	0.90	1.00	1.10	1.20	1.30	1.40	1.50
2,400	BHP	0.45	0.50	0.54	0.59	0.63	0.69	0.74	0.80	0.85	0.90	0.94	0.99	1.04	1.10	1.16	1.22
	Discrete Spd Setting	B	B	B	B	B	A	A	A	A	A	A	A	A	A	C	C
	RPM	578	625	665	705	745	785	820	860	895	925	960	990	1020	1050	1080	1110
2,500	BHP	0.50	0.55	0.59	0.64	0.69	0.75	0.81	0.88	0.92	0.97	1.01	1.06	1.12	1.17	1.23	1.29
	Discrete Spd Setting	B	B	B	B	A	A	A	A	A	A	A	A	A	C	C	C
	RPM	599	645	685	725	765	800	835	875	905	940	970	1005	1035	1060	1090	1120
2,600	BHP	0.55	0.60	0.65	0.69	0.75	0.80	0.86	0.92	0.97	1.02	1.08	1.13	1.19	1.25	1.30	1.36
	Discrete Spd Setting	B	B	B	B	A	A	A	A	A	A	A	A	A	C	C	C
	RPM	625	665	705	740	780	815	850	885	920	950	985	1015	1045	1075	1100	1130
2,700	BHP	0.60	0.65	0.70	0.75	0.80	0.86	0.91	0.97	1.02	1.08	1.14	1.20	1.26	1.32	1.38	1.44
	Discrete Spd Setting	B	B	B	A	A	A	A	A	A	A	A	A	C	C	C	C
	RPM	645	685	725	760	795	830	865	900	930	960	995	1025	1055	1085	1115	1140
2,800	BHP	0.65	0.71	0.76	0.82	0.87	0.93	0.98	1.04	1.10	1.16	1.21	1.28	1.36	1.43	1.50	1.56
	Discrete Spd Setting	B	B	B	A	A	A	A	A	A	A	A	A	C	C	C	C
	RPM	665	705	745	780	810	845	880	910	945	975	1005	1035	1065	1095	1125	1150
2,900	BHP	0.71	0.76	0.82	0.87	0.92	0.98	1.03	1.09	1.16	1.22	1.29	1.36	1.43	1.50	1.57	1.63
	Discrete Spd Setting	B	B	A	A	A	A	A	A	A	A	A	A	C	C	C	C
	RPM	685	720	760	795	825	860	890	920	955	985	1015	1045	1075	1105	1135	1160
3,000	BHP	0.78	0.84	0.89	0.95	1.00	1.06	1.12	1.18	1.24	1.30	1.37	1.43	1.50	1.58	1.64	1.71
	Discrete Spd Setting	B	B	A	A	A	A	A	A	A	A	A	C	C	C	C	C
	RPM	700	740	775	810	845	880	910	940	970	1000	1030	1055	1085	1115	1140	1170
3,100	BHP	0.85	0.91	0.96	1.02	1.08	1.14	1.22	1.29	1.36	1.44	1.50	1.57	1.63	1.70	1.76	1.82
	Discrete Spd Setting	B	B	A	A	A	A	A	A	A	A	A	C	C	C	C	C
	RPM	720	755	790	825	860	890	925	955	985	1015	1040	1070	1095	1125	1150	1175
3,200	BHP	0.93	1.00	1.07	1.14	1.20	1.26	1.32	1.38	1.44	1.51	1.57	1.64	1.70	1.78	1.85	1.92
	Discrete Spd Setting	B	A	A	A	A	A	A	A	A	A	C	C	C	C	C	C
	RPM	740	775	810	845	875	905	935	965	995	1025	1050	1080	1105	1135	1160	1185
3,300	BHP	1.01	1.08	1.14	1.21	1.28	1.33	1.39	1.45	1.51	1.58	1.64	1.72	1.78	1.84	1.93	2.00
	Discrete Spd Setting	B	A	A	A	A	A	A	A	A	A	C	C	C	C	C	C
	RPM	755	790	820	855	890	915	945	975	1005	1035	1060	1090	1115	1140	1170	1195
3,400	BHP	1.08	1.15	1.22	1.29	1.35	1.41	1.47	1.53	1.59	1.68	1.75	1.83	1.90	1.96	2.02	2.08
	Discrete Spd Setting	A	A	A	A	A	A	A	A	A	A	C	C	C	C	C	C
	RPM	765	800	835	870	900	930	960	990	1015	1045	1070	1100	1125	1150	1175	1200

Notes:

- Motor Sheave set to 1-turn open from factory.
- Factory torque setting is A. Torque setting is field-adjustable to any torque setting listed in drive table through the Wireless Service Tool.
- The unit can control the blower through LAT control. Enable this setting in the field with the Wireless Service Tool.
- The maximum allowable altitude of installation for this product is 6,561 ft (2,000 m).

Table continued on next page.

Blower Performance MB*096 with VFD

Models:
MB
072-300

Table continued from previous page

SCFM	ESP (in.w.c.)	0.00	0.10	0.20	0.30	0.40	0.50	0.60	0.70	0.80	0.90	1.00	1.10	1.20	1.30	1.40	1.50
3,500	BHP	1.16	1.23	1.29	1.36	1.42	1.48	1.54	1.60	1.66	1.73	1.79	1.85	1.92	2.01	2.09	2.17
	Discrete Spd Setting	A	A	A	A	A	A	A	A	A	C	C	C	C	C	C	C
	RPM	780	815	845	880	910	940	970	1000	1025	1055	1080	1105	1130	1160	1185	1210
3,600	BHP	1.24	1.30	1.37	1.44	1.51	1.58	1.65	1.72	1.78	1.86	1.92	1.98	2.06	2.13	2.21	2.29
	Discrete Spd Setting	A	A	A	A	A	A	A	A	A	C	C	C	C	C	C	C
	RPM	795	825	860	890	920	950	980	1010	1035	1065	1090	1115	1145	1165	1190	1215
3,700	BHP	1.34	1.40	1.46	1.53	1.61	1.68	1.75	1.82	1.90	1.97	2.06	2.13	2.21	2.28	2.36	2.44
	Discrete Spd Setting	A	A	A	A	A	A	A	A	C	C	C	C	C	C	C	C
	RPM	820	850	880	910	940	970	1000	1025	1055	1080	1110	1135	1160	1180	1205	1230
3,800	BHP	1.43	1.49	1.56	1.63	1.70	1.78	1.86	1.94	2.02	2.12	2.20	2.28	2.34	2.42	2.50	2.58
	Discrete Spd Setting	A	A	A	A	A	A	A	A	C	C	C	C	C	C	C	C
	RPM	840	870	900	930	960	990	1020	1045	1070	1100	1125	1150	1170	1195	1220	1245
3,900	BHP	1.58	1.64	1.71	1.78	1.85	1.93	2.01	2.09	2.19	2.27	2.35	2.41	2.49	2.57	2.65	
	Discrete Spd Setting	A	A	A	A	A	A	A	A	C	C	C	C	C	C	C	
	RPM	865	890	920	950	980	1010	1035	1060	1090	1115	1140	1160	1185	1210	1235	
4,000	BHP	1.68	1.75	1.83	1.92	2.00	2.08	2.16	2.26	2.34	2.42	2.50	2.56	2.64	2.72	2.80	
	Discrete Spd Setting	A	A	A	A	A	A	A	C	C	C	C	C	C	C	C	
	RPM	885	910	940	970	1000	1025	1050	1080	1105	1130	1155	1175	1200	1225	1250	

Notes:

- Motor Sheave set to 1-turn open from factory.
- Factory torque setting is A. Torque setting is field-adjustable to any torque setting listed in drive table through the Wireless Service Tool.
- The unit can control the blower through LAT control. Enable this setting in the field with the Wireless Service Tool.
- The maximum allowable altitude of installation for this product is 6,561 ft (2,000 m).

Blower Performance MB*120

Models:
MB
072-300

SCFM	ESP (in.w.c.)	0.00	0.10	0.20	0.30	0.40	0.50	0.60	0.70	0.80	0.90	1.00	1.10	1.20	1.30	1.40	1.50
3,000	BHP	0.75	0.81	0.86	0.91	0.97	1.03	1.09	1.15	1.21	1.27	1.34	1.41	1.47	1.54	1.61	1.67
	Sheave/Mtr	B	B	B	B	B	B	A	A	A	A	A	A	A	A	A	A
	RPM	680	720	755	790	825	860	895	925	955	985	1015	1045	1070	1100	1130	1155
3,100	BHP	0.82	0.88	0.94	0.99	1.04	1.10	1.17	1.26	1.33	1.40	1.46	1.53	1.59	1.66	1.72	1.80
	Sheave/Mtr	B	B	B	B	B	A	A	A	A	A	A	A	A	A	A	C
	RPM	700	735	775	805	840	875	905	940	970	1000	1025	1055	1080	1110	1135	1165
3,200	BHP	0.90	0.96	1.03	1.10	1.17	1.23	1.29	1.35	1.41	1.47	1.55	1.61	1.68	1.74	1.81	1.89
	Sheave/Mtr	B	B	B	B	B	A	A	A	A	A	A	A	A	A	A	C
	RPM	720	755	790	825	860	890	920	950	980	1010	1040	1065	1095	1120	1145	1175
3,300	BHP	0.98	1.04	1.11	1.18	1.25	1.31	1.37	1.43	1.49	1.55	1.62	1.68	1.75	1.81	1.88	1.95
	Sheave/Mtr	B	B	B	B	A	A	A	A	A	A	A	A	A	A	A	C
	RPM	740	770	805	840	875	905	935	965	995	1020	1050	1075	1105	1130	1155	1180
3,400	BHP	1.06	1.13	1.19	1.26	1.33	1.38	1.44	1.50	1.56	1.65	1.72	1.80	1.87	1.94	2.00	2.06
	Sheave/Mtr	B	B	B	B	A	A	A	A	A	A	A	A	A	A	C	C
	RPM	755	790	820	855	890	915	945	975	1005	1035	1060	1090	1115	1140	1165	1190
3,500	BHP	1.14	1.21	1.27	1.34	1.40	1.46	1.52	1.58	1.65	1.71	1.77	1.84	1.90	1.98	2.06	2.14
	Sheave/Mtr	B	B	B	A	A	A	A	A	A	A	A	A	A	A	C	C
	RPM	770	805	835	870	900	930	960	990	1020	1045	1070	1100	1125	1150	1175	1200
3,600	BHP	1.23	1.29	1.36	1.42	1.50	1.57	1.64	1.71	1.77	1.84	1.90	1.96	2.05	2.13	2.21	2.27
	Sheave/Mtr	B	B	B	A	A	A	A	A	A	A	A	A	A	C	C	C
	RPM	790	820	855	885	915	945	975	1005	1030	1060	1085	1110	1140	1165	1190	1210
3,700	BHP	1.32	1.38	1.44	1.51	1.58	1.65	1.73	1.81	1.88	1.96	2.03	2.10	2.18	2.26	2.34	2.42
	Sheave/Mtr	B	B	A	A	A	A	A	A	A	A	A	A	A	C	C	C
	RPM	810	840	870	900	930	960	990	1020	1045	1075	1100	1125	1150	1175	1200	1225
3,800	BHP	1.41	1.47	1.54	1.61	1.68	1.75	1.82	1.91	1.99	2.07	2.17	2.25	2.31	2.39	2.47	2.55
	Sheave/Mtr	B	B	A	A	A	A	A	A	A	A	A	A	A	C	C	C
	RPM	830	860	890	920	950	980	1005	1035	1060	1085	1115	1140	1160	1185	1210	1235
3,900	BHP	1.54	1.60	1.67	1.74	1.82	1.89	1.96	2.04	2.14	2.22	2.30	2.38	2.46	2.52	2.60	2.68
	Sheave/Mtr	B	A	A	A	A	A	A	A	A	A	A	A	C	C	C	C
	RPM	850	875	905	935	965	995	1020	1045	1075	1100	1125	1150	1175	1195	1220	1245
4,000	BHP	1.63	1.71	1.78	1.86	1.94	2.03	2.11	2.19	2.27	2.37	2.45	2.51	2.59	2.67	2.75	2.85
	Sheave/Mtr	A	A	A	A	A	A	A	A	A	A	A	A	C	C	C	C
	RPM	865	895	920	950	980	1010	1035	1060	1085	1115	1140	1160	1185	1210	1235	1260
4,100	BHP	1.73	1.81	1.90	1.97	2.05	2.12	2.20	2.27	2.34	2.42	2.52	2.62	2.70	2.80	2.90	
	Sheave/Mtr	A	A	A	A	A	A	A	A	A	A	A	C	C	C	C	
	RPM	885	915	945	970	1000	1025	1055	1080	1105	1130	1155	1180	1200	1225	1250	
4,200	BHP	1.87	1.94	2.02	2.08	2.16	2.24	2.32	2.40	2.48	2.58	2.68	2.76	2.86	2.96		
	Sheave/Mtr	A	A	A	A	A	A	A	A	A	A	C	C	C	C		
	RPM	905	935	965	990	1020	1045	1070	1095	1120	1145	1170	1190	1215	1240		

- Notes:
- A, 1 = Standard RPM/Standard Blower Motor
 - E, 5 = High RPM/Large Blower Motor
 - The maximum allowable altitude of installation for this product is 6,561 ft (2,000 m).

Table continued on next page.

Blower Performance MB*120

Models:
MB
072-300

Table continued from previous page

SCFM	ESP (in.w.c.)	0.00	0.10	0.20	0.30	0.40	0.50	0.60	0.70	0.80	0.90	1.00	1.10	1.20	1.30	1.40	1.50	
4,300	BHP	2.00	2.07	2.16	2.23	2.31	2.41	2.49	2.57	2.66	2.74	2.84	2.94	3.02	3.15			
	Sheave/Mtr	A	A	A	A	A	A	A	A	A	C	C	C	E	E			
	RPM	930	955	985	1010	1035	1065	1090	1115	1140	1160	1185	1210	1230	1255			
4,400	BHP	2.14	2.22	2.32	2.40	2.48	2.56	2.65	2.74	2.82	2.92	3.00	3.10	3.18				
	Sheave/Mtr	A	A	A	A	A	A	A	A	A	C	E	E	E				
	RPM	950	975	1005	1030	1055	1080	1110	1135	1155	1180	1200	1225	1245				
4,500	BHP	2.30	2.38	2.46	2.54	2.62	2.72	2.80	2.88	3.00	3.08	3.16	3.26					
	Sheave/Mtr	A	A	A	A	A	A	A	A	D	E	E	E					
	RPM	970	995	1020	1045	1070	1100	1125	1145	1170	1195	1215	1240					
4,600	BHP	2.39	2.45	2.54	2.63	2.72	2.83	2.92	3.00	3.10	3.18	3.28	3.38					
	Sheave/Mtr	A	A	A	A	A	A	A	D	D	E	E	E					
	RPM	980	1000	1025	1050	1075	1105	1130	1150	1175	1195	1220	1245					
4,700	BHP	2.46	2.52	2.62	2.72	2.82	2.92	3.02	3.12	3.22	3.32	3.40	3.50					
	Sheave/Mtr	A	A	A	A	A	A	D	D	E	E	E	E					
	RPM	985	1005	1030	1055	1080	1105	1130	1155	1180	1205	1225	1250					
4,800	BHP	2.57	2.64	2.74	2.84	2.94	3.04	3.14	3.24	3.32	3.42	3.52	3.60					
	Sheave/Mtr	A	A	A	A	A	D	D	D	E	E	E	E					
	RPM	990	1010	1035	1060	1085	1110	1135	1160	1180	1205	1230	1250					
4,900	BHP	2.68	2.78	2.88	3.00	3.06	3.16	3.26	3.36	3.44	3.54	3.64	3.75					
	Sheave/Mtr	A	A	A	D	D	D	D	E	E	E	E	E					
	RPM	995	1020	1045	1070	1090	1115	1140	1165	1185	1210	1235	1255					
5,000	BHP	2.82	2.92	3.00	3.10	3.20	3.28	3.38	3.48	3.56	3.66	3.74						
	Sheave/Mtr	A	A	D	D	D	D	D	E	E	E	E						
	RPM	1005	1030	1050	1075	1100	1120	1145	1170	1190	1215	1235						

Notes:

- A, 1 = Standard RPM/Standard Blower Motor
- E, 5 = High RPM/Large Blower Motor
- The maximum allowable altitude of installation for this product is 6,561 ft (2,000 m).

Blower Performance MB*120 with VFD

Models:
MB
072-300

SCFM	ESP (in.w.c.)	0.00	0.10	0.20	0.30	0.40	0.50	0.60	0.70	0.80	0.90	1.00	1.10	1.20	1.30	1.40	1.50
3,000	BHP	0.75	0.81	0.86	0.91	0.97	1.03	1.09	1.15	1.21	1.27	1.34	1.41	1.47	1.54	1.61	1.67
	Discrete Spd Setting	B	B	B	B	B	B	A	A	A	A	A	A	A	A	A	A
	RPM	680	720	755	790	825	860	895	925	955	985	1015	1045	1070	1100	1130	1155
3,100	BHP	0.82	0.88	0.94	0.99	1.04	1.10	1.17	1.26	1.33	1.40	1.46	1.53	1.59	1.66	1.72	1.80
	Discrete Spd Setting	B	B	B	B	B	A	A	A	A	A	A	A	A	A	A	C
	RPM	700	735	775	805	840	875	905	940	970	1000	1025	1055	1080	1110	1135	1165
3,200	BHP	0.90	0.96	1.03	1.10	1.17	1.23	1.29	1.35	1.41	1.47	1.55	1.61	1.68	1.74	1.81	1.89
	Discrete Spd Setting	B	B	B	B	B	A	A	A	A	A	A	A	A	A	A	C
	RPM	720	755	790	825	860	890	920	950	980	1010	1040	1065	1095	1120	1145	1175
3,300	BHP	0.98	1.04	1.11	1.18	1.25	1.31	1.37	1.43	1.49	1.55	1.62	1.68	1.75	1.81	1.88	1.95
	Discrete Spd Setting	B	B	B	B	A	A	A	A	A	A	A	A	A	A	A	C
	RPM	740	770	805	840	875	905	935	965	995	1020	1050	1075	1105	1130	1155	1180
3,400	BHP	1.06	1.13	1.19	1.26	1.33	1.38	1.44	1.50	1.56	1.65	1.72	1.80	1.87	1.94	2.00	2.06
	Discrete Spd Setting	B	B	B	B	A	A	A	A	A	A	A	A	A	A	C	C
	RPM	755	790	820	855	890	915	945	975	1005	1035	1060	1090	1115	1140	1165	1190
3,500	BHP	1.14	1.21	1.27	1.34	1.40	1.46	1.52	1.58	1.65	1.71	1.77	1.84	1.90	1.98	2.06	2.14
	Discrete Spd Setting	B	B	B	A	A	A	A	A	A	A	A	A	A	A	C	C
	RPM	770	805	835	870	900	930	960	990	1020	1045	1070	1100	1125	1150	1175	1200
3,600	BHP	1.23	1.29	1.36	1.42	1.50	1.57	1.64	1.71	1.77	1.84	1.90	1.96	2.05	2.13	2.21	2.27
	Discrete Spd Setting	B	B	B	A	A	A	A	A	A	A	A	A	A	C	C	C
	RPM	790	820	855	885	915	945	975	1005	1030	1060	1085	1110	1140	1165	1190	1210
3,700	BHP	1.32	1.38	1.44	1.51	1.58	1.65	1.73	1.81	1.88	1.96	2.03	2.10	2.18	2.26	2.34	2.42
	Discrete Spd Setting	B	B	A	A	A	A	A	A	A	A	A	A	A	C	C	C
	RPM	810	840	870	900	930	960	990	1020	1045	1075	1100	1125	1150	1175	1200	1225
3,800	BHP	1.41	1.47	1.54	1.61	1.68	1.75	1.82	1.91	1.99	2.07	2.17	2.25	2.31	2.39	2.47	2.55
	Discrete Spd Setting	B	B	A	A	A	A	A	A	A	A	A	A	A	C	C	C
	RPM	830	860	890	920	950	980	1005	1035	1060	1085	1115	1140	1160	1185	1210	1235
3,900	BHP	1.54	1.60	1.67	1.74	1.82	1.89	1.96	2.04	2.14	2.22	2.30	2.38	2.46	2.52	2.60	2.68
	Discrete Spd Setting	B	A	A	A	A	A	A	A	A	A	A	A	C	C	C	C
	RPM	850	875	905	935	965	995	1020	1045	1075	1100	1125	1150	1175	1195	1220	1245
4,000	BHP	1.63	1.71	1.78	1.86	1.94	2.03	2.11	2.19	2.27	2.37	2.45	2.51	2.59	2.67	2.75	2.85
	Discrete Spd Setting	A	A	A	A	A	A	A	A	A	A	A	A	C	C	C	C
	RPM	865	895	920	950	980	1010	1035	1060	1085	1115	1140	1160	1185	1210	1235	1260
4,100	BHP	1.73	1.81	1.90	1.97	2.05	2.12	2.20	2.27	2.34	2.42	2.52	2.62	2.70	2.80	2.90	
	Discrete Spd Setting	A	A	A	A	A	A	A	A	A	A	A	C	C	C	C	
	RPM	885	915	945	970	1000	1025	1055	1080	1105	1130	1155	1180	1200	1225	1250	
4,200	BHP	1.87	1.94	2.02	2.08	2.16	2.24	2.32	2.40	2.48	2.58	2.68	2.76	2.86	2.96		
	Discrete Spd Setting	A	A	A	A	A	A	A	A	A	A	C	C	C	C		
	RPM	905	935	965	990	1020	1045	1070	1095	1120	1145	1170	1190	1215	1240		
4,300	BHP	2.00	2.07	2.16	2.23	2.31	2.41	2.49	2.57	2.66	2.74	2.84	2.94	3.02	3.15		
	Discrete Spd Setting	A	A	A	A	A	A	A	A	A	C	C	C	E	E		
	RPM	930	955	985	1010	1035	1065	1090	1115	1140	1160	1185	1210	1230	1255		

Notes:

- Motor Sheave set to 1-turn open from factory.
- Factory torque setting is A. Torque setting is field-adjustable to any torque setting listed in drive table through the Wireless Service Tool.
- The unit can control the blower through LAT control. Enable this setting in the field with the Wireless Service Tool.
- The maximum allowable altitude of installation for this product is 6,561 ft (2,000 m).

Table continued on next page.

Blower Performance MB*120 with VFD

Models:
MB
072-300

Table continued from previous page

SCFM	ESP (in.w.c.)	0.00	0.10	0.20	0.30	0.40	0.50	0.60	0.70	0.80	0.90	1.00	1.10	1.20	1.30	1.40	1.50
4,400	BHP	2.14	2.22	2.32	2.40	2.48	2.56	2.65	2.74	2.82	2.92	3.00	3.10	3.18			
	Discrete Spd Setting	A	A	A	A	A	A	A	A	A	C	C	C	C			
	RPM	950	975	1005	1030	1055	1080	1110	1135	1155	1180	1200	1225	1245			
4,500	BHP	2.30	2.38	2.46	2.54	2.62	2.72	2.80	2.88	3.00	3.08	3.16	3.26				
	Discrete Spd Setting	A	A	A	A	A	A	A	A	A	C	C	C				
	RPM	970	995	1020	1045	1070	1100	1125	1145	1170	1195	1215	1240				
4,600	BHP	2.39	2.45	2.54	2.63	2.72	2.83	2.92	3.00	3.10	3.18	3.28	3.38				
	Discrete Spd Setting	A	A	A	A	A	A	A	A	A	C	C	C				
	RPM	980	1000	1025	1050	1075	1105	1130	1150	1175	1195	1220	1245				
4,700	BHP	2.46	2.52	2.62	2.72	2.82	2.92	3.02	3.12	3.22	3.32	3.40	3.50				
	Discrete Spd Setting	A	A	A	A	A	A	A	A	C	C	C	C				
	RPM	985	1005	1030	1055	1080	1105	1130	1155	1180	1205	1225	1250				
4,800	BHP	2.57	2.64	2.74	2.84	2.94	3.04	3.14	3.24	3.32	3.42	3.52	3.60				
	Discrete Spd Setting	A	A	A	A	A	A	A	A	C	C	C	C				
	RPM	990	1010	1035	1060	1085	1110	1135	1160	1180	1205	1230	1250				
4,900	BHP	2.68	2.78	2.88	3.00	3.06	3.16	3.26	3.36	3.44	3.54	3.64	3.75				
	Discrete Spd Setting	A	A	A	A	A	A	A	C	C	C	C	C				
	RPM	995	1020	1045	1070	1090	1115	1140	1165	1185	1210	1235	1255				
5,000	BHP	2.82	2.92	3.00	3.10	3.20	3.28	3.38	3.48	3.56	3.66	3.74					
	Discrete Spd Setting	A	A	A	A	A	A	A	C	C	C	C					
	RPM	1005	1030	1050	1075	1100	1120	1145	1170	1190	1215	1235					

Notes:

- Motor Sheave set to 1-turn open from factory.
- Factory torque setting is A. Torque setting is field-adjustable to any torque setting listed in drive table through the Wireless Service Tool.
- The unit can control the blower through LAT control. Enable this setting in the field with the Wireless Service Tool.
- The maximum allowable altitude of installation for this product is 6,561 ft (2,000 m).

Blower Performance MB*168

Models:
MB
072-300

SCFM	ESP (in.w.c.)	0.00	0.10	0.20	0.30	0.40	0.50	0.60	0.70	0.80	0.90	1.00	1.10	1.20	1.30	1.40	1.50
4,200	BHP			0.69	0.78	0.86	0.95	1.02	1.11	1.21	1.32	1.41	1.50	1.57	1.64	1.72	1.80
	Sheave/Mtr			B	B	B	B	A	A	A	A	A	A	A	C	C	C
	RPM			547	594	640	685	725	765	805	845	880	915	945	975	1005	1030
4,400	BHP			0.75	0.83	0.92	1.01	1.11	1.21	1.31	1.41	1.51	1.60	1.68	1.76	1.85	1.94
	Sheave/Mtr			B	B	B	B	A	A	A	A	A	A	A	C	C	C
	RPM			563	609	655	695	735	775	815	855	890	925	955	985	1015	1045
4,600	BHP		0.75	0.85	0.95	1.03	1.11	1.19	1.30	1.40	1.50	1.60	1.70	1.78	1.89	2.00	2.10
	Sheave/Mtr		B	B	B	B	B	A	A	A	A	A	A	C	C	C	C
	RPM		526	573	625	665	705	745	785	825	860	895	930	960	995	1025	1050
4,800	BHP		0.83	0.94	1.03	1.12	1.20	1.30	1.40	1.53	1.63	1.73	1.82	1.92	2.00	2.12	2.22
	Sheave/Mtr		B	B	B	B	A	A	A	A	A	A	A	C	C	C	C
	RPM		542	594	640	680	720	760	795	835	870	905	935	970	1000	1030	1055
5,000	BHP		0.93	1.02	1.11	1.20	1.31	1.41	1.52	1.64	1.76	1.85	1.95	2.03	2.12	2.24	2.36
	Sheave/Mtr		B	B	B	B	A	A	A	A	A	A	A	C	C	C	C
	RPM		563	609	650	690	735	770	805	840	880	910	945	975	1005	1035	1065
5,200	BHP	0.93	1.02	1.10	1.20	1.29	1.39	1.50	1.61	1.72	1.83	1.94	2.06	2.15	2.26	2.38	2.50
	Sheave/Mtr	B	B	B	B	B	A	A	A	A	A	A	A	C	C	C	C
	RPM	542	583	625	665	705	745	780	815	850	885	920	955	985	1015	1045	1075
5,400	BHP	1.03	1.10	1.19	1.29	1.39	1.50	1.59	1.70	1.80	1.92	2.03	2.16	2.26	2.38	2.50	2.62
	Sheave/Mtr	B	B	B	B	B	A	A	A	A	A	A	C	C	C	C	C
	RPM	563	599	640	680	720	760	790	825	860	895	925	960	990	1020	1050	1080
5,600	BHP	1.12	1.19	1.28	1.39	1.50	1.61	1.72	1.84	1.93	2.06	2.17	2.29	2.40	2.54	2.69	2.83
	Sheave/Mtr	B	B	B	B	A	A	A	A	A	A	A	C	C	C	C	C
	RPM	583	620	655	695	735	770	805	840	870	905	935	970	1000	1030	1060	1090
5,800	BHP	1.17	1.28	1.39	1.49	1.60	1.70	1.81	1.90	2.02	2.14	2.28	2.40	2.52	2.67	2.81	2.96
	Sheave/Mtr	B	B	B	B	A	A	A	A	A	A	A	C	C	C	C	C
	RPM	588	630	670	710	750	780	815	845	880	910	945	975	1005	1035	1065	1095
6,000	BHP	1.25	1.40	1.51	1.61	1.73	1.84	1.94	2.05	2.18	2.30	2.42	2.54	2.67	2.79	2.94	3.08
	Sheave/Mtr	B	B	B	A	A	A	A	A	A	A	A	C	C	C	C	E
	RPM	604	645	685	720	760	795	825	860	895	925	955	985	1015	1040	1070	1100
6,200	BHP	1.40	1.51	1.62	1.75	1.86	1.98	2.09	2.20	2.34	2.49	2.63	2.78	2.92	3.06	3.18	
	Sheave/Mtr	B	B	B	A	A	A	A	A	A	A	C	C	C	E	E	
	RPM	625	660	695	735	770	805	840	875	905	935	965	995	1025	1055	1080	
6,400	BHP	1.55	1.68	1.79	1.90	2.04	2.18	2.32	2.44	2.56	2.68	2.80	2.92	3.07	3.19	3.33	
	Sheave/Mtr	B	B	B	A	A	A	A	A	A	A	C	C	E	E	E	
	RPM	640	680	715	750	785	820	855	885	915	945	975	1005	1035	1060	1090	
6,600	BHP	1.73	1.84	1.94	2.06	2.20	2.34	2.46	2.58	2.70	2.82	2.94	3.07	3.19	3.34	3.46	
	Sheave/Mtr	B	B	A	A	A	A	A	A	A	A	C	E	E	E	E	
	RPM	665	700	730	765	800	835	865	895	925	955	985	1015	1040	1070	1095	
6,800	BHP	1.87	1.98	2.08	2.20	2.34	2.48	2.62	2.74	2.86	2.96	3.08	3.24	3.38	3.55		
	Sheave/Mtr	B	B	A	A	A	A	A	A	A	C	E	E	E	E		
	RPM	685	715	745	775	810	845	880	910	940	965	995	1025	1050	1080		
7,000	BHP	2.03	2.13	2.22	2.36	2.50	2.62	2.76	2.88	3.00	3.12	3.22	3.37	3.49	3.61		
	Sheave/Mtr	B	A	A	A	A	A	A	A	D	E	E	E	E	E		
	RPM	705	730	755	790	825	855	890	920	950	980	1005	1035	1060	1085		

Notes:

- A, 1 = Standard RPM/Standard Blower Motor
- E, 5 = High RPM/Large Blower Motor
- The maximum allowable altitude of installation for this product is 6,561 ft (2,000 m).

Blower Performance MB168 with VFD

Models:
MB
072-300

SCFM	ESP (in.w.c.)	0.00	0.10	0.20	0.30	0.40	0.50	0.60	0.70	0.80	0.90	1.00	1.10	1.20	1.30	1.40	1.50
4,200	BHP			0.69	0.78	0.86	0.95	1.02	1.11	1.21	1.32	1.41	1.50	1.57	1.64	1.72	1.80
	Discrete Spd Setting			B	B	B	B	A	A	A	A	A	A	A	C	C	C
	RPM			547	594	640	685	725	765	805	845	880	915	945	975	1005	1030
4,400	BHP			0.75	0.83	0.92	1.01	1.11	1.21	1.31	1.41	1.51	1.60	1.68	1.76	1.85	1.94
	Discrete Spd Setting			B	B	B	B	A	A	A	A	A	A	A	C	C	C
	RPM			563	609	655	695	735	775	815	855	890	925	955	985	1015	1045
4,600	BHP		0.75	0.85	0.95	1.03	1.11	1.19	1.30	1.40	1.50	1.60	1.70	1.78	1.89	2.00	2.10
	Discrete Spd Setting		B	B	B	B	B	A	A	A	A	A	A	C	C	C	C
	RPM		526	573	625	665	705	745	785	825	860	895	930	960	995	1025	1050
4,800	BHP		0.83	0.94	1.03	1.12	1.20	1.30	1.40	1.53	1.63	1.73	1.82	1.92	2.00	2.12	2.22
	Discrete Spd Setting		B	B	B	B	A	A	A	A	A	A	A	C	C	C	C
	RPM		542	594	640	680	720	760	795	835	870	905	935	970	1000	1030	1055
5,000	BHP		0.93	1.02	1.11	1.20	1.31	1.41	1.52	1.64	1.76	1.85	1.95	2.03	2.12	2.24	2.36
	Discrete Spd Setting		B	B	B	B	A	A	A	A	A	A	A	C	C	C	C
	RPM		563	609	650	690	735	770	805	840	880	910	945	975	1005	1035	1065
5,200	BHP	0.93	1.02	1.10	1.20	1.29	1.39	1.50	1.61	1.72	1.83	1.94	2.06	2.15	2.26	2.38	2.50
	Discrete Spd Setting	B	B	B	B	B	A	A	A	A	A	A	A	C	C	C	C
	RPM	542	583	625	665	705	745	780	815	850	885	920	955	985	1015	1045	1075
5,400	BHP	1.03	1.10	1.19	1.29	1.39	1.50	1.59	1.70	1.80	1.92	2.03	2.16	2.26	2.38	2.50	2.62
	Discrete Spd Setting	B	B	B	B	B	A	A	A	A	A	A	C	C	C	C	C
	RPM	563	599	640	680	720	760	790	825	860	895	925	960	990	1020	1050	1080
5,600	BHP	1.12	1.19	1.28	1.39	1.50	1.61	1.72	1.84	1.93	2.06	2.17	2.29	2.40	2.54	2.69	2.83
	Discrete Spd Setting	B	B	B	B	A	A	A	A	A	A	A	C	C	C	C	C
	RPM	583	620	655	695	735	770	805	840	870	905	935	970	1000	1030	1060	1090
5,800	BHP	1.17	1.28	1.39	1.49	1.60	1.70	1.81	1.90	2.02	2.14	2.28	2.40	2.52	2.67	2.81	2.96
	Discrete Spd Setting	B	B	B	B	A	A	A	A	A	A	A	C	C	C	C	C
	RPM	588	630	670	710	750	780	815	845	880	910	945	975	1005	1035	1065	1095
6,000	BHP	1.25	1.40	1.51	1.61	1.73	1.84	1.94	2.05	2.18	2.30	2.42	2.54	2.67	2.79	2.94	3.08
	Discrete Spd Setting	B	B	B	A	A	A	A	A	A	A	A	C	C	C	C	C
	RPM	604	645	685	720	760	795	825	860	895	925	955	985	1015	1040	1070	1100
6,200	BHP	1.40	1.51	1.62	1.75	1.86	1.98	2.09	2.20	2.34	2.49	2.63	2.78	2.92	3.06	3.18	
	Discrete Spd Setting	B	B	B	A	A	A	A	A	A	A	C	C	C	C	C	
	RPM	625	660	695	735	770	805	840	875	905	935	965	995	1025	1055	1080	
6,400	BHP	1.55	1.68	1.79	1.90	2.04	2.18	2.32	2.44	2.56	2.68	2.80	2.92	3.07	3.19	3.33	
	Discrete Spd Setting	B	B	B	A	A	A	A	A	A	A	C	C	C	C	C	
	RPM	640	680	715	750	785	820	855	885	915	945	975	1005	1035	1060	1090	
6,600	BHP	1.73	1.84	1.94	2.06	2.20	2.34	2.46	2.58	2.70	2.82	2.94	3.07	3.19	3.34	3.46	
	Discrete Spd Setting	B	B	A	A	A	A	A	A	A	A	C	C	C	C	C	
	RPM	665	700	730	765	800	835	865	895	925	955	985	1015	1040	1070	1095	
6,800	BHP	1.87	1.98	2.08	2.20	2.34	2.48	2.62	2.74	2.86	2.96	3.08	3.24	3.38	3.55		
	Discrete Spd Setting	B	B	A	A	A	A	A	A	A	C	C	C	C	C		
	RPM	685	715	745	775	810	845	880	910	940	965	995	1025	1050	1080		
7,000	BHP	2.03	2.13	2.22	2.36	2.50	2.62	2.76	2.88	3.00	3.12	3.22	3.37	3.49	3.61		
	Discrete Spd Setting	B	A	A	A	A	A	A	A	A	C	C	C	C	C		
	RPM	705	730	755	790	825	855	890	920	950	980	1005	1035	1060	1085		

Notes:

- Motor Sheave set to 1-turn open from factory.
- Factory torque setting is A. Torque setting is field-adjustable to any torque setting listed in drive table through the Wireless Service Tool.
- The unit can control the blower through LAT control. Enable this setting in the field with the Wireless Service Tool.
- The maximum allowable altitude of installation for this product is 6,561 ft (2,000 m).

Blower Performance MB192

Models:
MB
072-300

SCFM	ESP (in.w.c.)	0.00	0.10	0.20	0.30	0.40	0.50	0.60	0.70	0.80	0.90	1.00	1.10	1.20	1.30	1.40	1.50
4,800	BHP		0.98	1.07	1.16	1.24	1.34	1.47	1.59	1.69	1.78	1.87	1.96	2.06	2.18	2.30	2.42
	Sheave/Mtr		B	B	B	B	A	A	A	A	A	A	A	C	C	C	C
	RPM		615	660	700	740	775	815	855	890	920	955	985	1015	1045	1075	1105
5,000	BHP	0.99	1.07	1.18	1.27	1.37	1.49	1.60	1.73	1.82	1.92	2.00	2.10	2.22	2.32	2.44	2.56
	Sheave/Mtr	B	B	B	B	A	A	A	A	A	A	A	A	C	C	C	C
	RPM	594	635	680	720	760	795	830	870	900	935	965	1000	1030	1055	1085	1115
5,200	BHP	1.09	1.18	1.28	1.36	1.48	1.59	1.70	1.82	1.93	2.02	2.14	2.24	2.36	2.48	2.60	2.72
	Sheave/Mtr	B	B	B	B	A	A	A	A	A	A	A	C	C	C	C	C
	RPM	620	660	700	735	775	810	845	880	915	945	980	1010	1040	1070	1100	1130
5,400	BHP	1.19	1.29	1.39	1.48	1.59	1.70	1.80	1.92	2.03	2.16	2.26	2.38	2.50	2.62	2.74	2.87
	Sheave/Mtr	B	B	B	A	A	A	A	A	A	A	A	C	C	C	C	C
	RPM	640	680	720	755	790	825	860	895	925	960	990	1020	1050	1080	1110	1140
5,600	BHP	1.30	1.40	1.51	1.62	1.74	1.85	1.95	2.08	2.18	2.31	2.42	2.57	2.71	2.86	2.98	3.12
	Sheave/Mtr	B	B	B	A	A	A	A	A	A	A	C	C	C	C	C	E
	RPM	660	700	740	775	810	845	875	910	940	975	1005	1035	1065	1095	1120	1150
5,800	BHP	1.41	1.52	1.63	1.73	1.84	1.95	2.06	2.18	2.32	2.44	2.57	2.72	2.86	3.00	3.15	3.27
	Sheave/Mtr	B	B	A	A	A	A	A	A	A	A	C	C	C	E	E	E
	RPM	680	720	760	790	825	860	890	920	955	985	1015	1045	1075	1105	1135	1160
6,000	BHP	1.56	1.67	1.78	1.89	2.00	2.12	2.24	2.36	2.48	2.60	2.74	2.89	3.01	3.15	3.30	3.42
	Sheave/Mtr	B	B	A	A	A	A	A	A	A	C	C	C	E	E	E	E
	RPM	700	740	775	810	845	880	910	940	970	1000	1030	1060	1085	1115	1145	1170
6,200	BHP	1.70	1.83	1.94	2.06	2.17	2.30	2.44	2.58	2.73	2.87	3.02	3.14	3.28	3.40	3.54	3.66
	Sheave/Mtr	B	A	A	A	A	A	A	A	A	C	E	E	E	E	E	E
	RPM	720	760	795	830	865	895	925	955	985	1015	1045	1070	1100	1125	1155	1180
6,400	BHP	1.88	2.02	2.16	2.28	2.42	2.54	2.66	2.78	2.90	3.04	3.16	3.31	3.43	3.58	3.72	3.86
	Sheave/Mtr	B	A	A	A	A	A	A	A	C	E	E	E	E	E	E	E
	RPM	745	780	815	845	880	910	940	970	1000	1030	1055	1085	1110	1140	1165	1190
6,600	BHP	2.06	2.18	2.32	2.46	2.58	2.70	2.82	2.94	3.07	3.19	3.34	3.46	3.60	3.74	3.88	4.02
	Sheave/Mtr	A	A	A	A	A	A	A	A	E	E	E	E	E	E	E	E
	RPM	765	795	830	865	895	925	955	985	1015	1040	1070	1095	1125	1150	1175	1200
6,800	BHP	2.22	2.36	2.50	2.62	2.74	2.86	3.00	3.10	3.27	3.41	3.58	3.72	3.85	3.97	4.11	4.23
	Sheave/Mtr	A	A	A	A	A	A	D	D	E	E	E	E	E	E	E	E
	RPM	780	815	850	880	910	940	970	1000	1030	1055	1085	1110	1135	1160	1190	1215
7,000	BHP	2.40	2.54	2.66	2.80	2.92	3.04	3.14	3.27	3.39	3.54	3.66	3.78	3.96	4.12	4.28	4.44
	Sheave/Mtr	A	A	A	A	A	D	D	E	E	E	E	E	E	E	E	E
	RPM	800	835	865	900	930	960	985	1015	1040	1070	1095	1120	1150	1175	1200	1225

Notes:

- A, 1 = Standard RPM/Standard Blower Motor
- E, 5 = High RPM/Large Blower Motor
- The maximum allowable altitude of installation for this product is 6,561 ft (2,000 m).

Table continued on next page.

Blower Performance MB192

Models:
MB
072-300

Table continued from previous page

SCFM	ESP (in.w.c.)	0.00	0.10	0.20	0.30	0.40	0.50	0.60	0.70	0.80	0.90	1.00	1.10	1.20	1.30	1.40	1.50
7,200	BHP	2.58	2.70	2.85	2.99	3.14	3.28	3.42	3.54	3.66	3.81	3.93	4.06	4.22	4.38	4.54	4.70
	Sheave/Mtr	A	A	A	A	D	D	E	E	E	E	E	E	E	E	E	E
	RPM	820	850	885	915	945	975	1005	1030	1055	1085	1110	1135	1160	1185	1210	1235
7,400	BHP	2.76	2.88	3.02	3.16	3.31	3.45	3.61	3.75	3.92	4.06	4.20	4.36	4.52	4.68	4.81	4.97
	Sheave/Mtr	A	A	D	D	D	D	E	E	E	E	E	E	E	E	E	E
	RPM	840	870	900	930	960	990	1020	1045	1075	1100	1125	1150	1175	1200	1220	1245
7,600	BHP	2.94	3.07	3.22	3.36	3.50	3.63	3.82	3.98	4.14	4.34	4.50	4.66	4.78	4.94		
	Sheave/Mtr	A	D	D	D	D	E	E	E	E	E	E	E	E	E		
	RPM	860	890	920	950	980	1005	1035	1060	1085	1115	1140	1165	1185	1210		
7,800	BHP	3.22	3.34	3.49	3.63	3.78	3.96	4.12	4.28	4.44	4.63	4.76	4.92				
	Sheave/Mtr	D	D	D	D	D	E	E	E	E	E	E	E				
	RPM	880	905	935	965	995	1025	1050	1075	1100	1130	1150	1175				
8,000	BHP	3.41	3.58	3.75	3.92	4.06	4.26	4.42	4.58	4.74	4.90						
	Sheave/Mtr	D	D	D	D	E	E	E	E	E	E						
	RPM	895	925	955	985	1010	1040	1065	1090	1115	1140						

Notes:

- A, 1 = Standard RPM/Standard Blower Motor
- E, 5 = High RPM/Large Blower Motor
- The maximum allowable altitude of installation for this product is 6,561 ft (2,000 m).

Blower Performance MB192 with VFD

Models:
MB
072-300

SCFM	ESP (in.w.c.)	0.00	0.10	0.20	0.30	0.40	0.50	0.60	0.70	0.80	0.90	1.00	1.10	1.20	1.30	1.40	1.50
4,800	BHP		0.98	1.07	1.16	1.24	1.34	1.47	1.59	1.69	1.78	1.87	1.96	2.06	2.18	2.30	2.42
	Discrete Spd Setting		B	B	B	B	A	A	A	A	A	A	A	C	C	C	C
	RPM		615	660	700	740	775	815	855	890	920	955	985	1015	1045	1075	1105
5,000	BHP	0.99	1.07	1.18	1.27	1.37	1.49	1.60	1.73	1.82	1.92	2.00	2.10	2.22	2.32	2.44	2.56
	Discrete Spd Setting	B	B	B	B	A	A	A	A	A	A	A	A	C	C	C	C
	RPM	594	635	680	720	760	795	830	870	900	935	965	1000	1030	1055	1085	1115
5,200	BHP	1.09	1.18	1.28	1.36	1.48	1.59	1.70	1.82	1.93	2.02	2.14	2.24	2.36	2.48	2.60	2.72
	Sheave/Mtr	B	B	B	B	A	A	A	A	A	A	A	C	C	C	C	C
	RPM	620	660	700	735	775	810	845	880	915	945	980	1010	1040	1070	1100	1130
5,400	BHP	1.19	1.29	1.39	1.48	1.59	1.70	1.80	1.92	2.03	2.16	2.26	2.38	2.50	2.62	2.74	2.87
	Discrete Spd Setting	B	B	B	A	A	A	A	A	A	A	A	C	C	C	C	C
	RPM	640	680	720	755	790	825	860	895	925	960	990	1020	1050	1080	1110	1140
5,600	BHP	1.30	1.40	1.51	1.62	1.74	1.85	1.95	2.08	2.18	2.31	2.42	2.57	2.71	2.86	2.98	3.12
	Sheave/Mtr	B	B	B	A	A	A	A	A	A	A	C	C	C	C	C	C
	RPM	660	700	740	775	810	845	875	910	940	975	1005	1035	1065	1095	1120	1150
5,800	BHP	1.41	1.52	1.63	1.73	1.84	1.95	2.06	2.18	2.32	2.44	2.57	2.72	2.86	3.00	3.15	3.27
	Discrete Spd Setting	B	B	A	A	A	A	A	A	A	A	C	C	C	C	C	C
	RPM	680	720	760	790	825	860	890	920	955	985	1015	1045	1075	1105	1135	1160
6,000	BHP	1.56	1.67	1.78	1.89	2.00	2.12	2.24	2.36	2.48	2.60	2.74	2.89	3.01	3.15	3.30	3.42
	Discrete Spd Setting	B	B	A	A	A	A	A	A	A	C	C	C	C	C	C	C
	RPM	700	740	775	810	845	880	910	940	970	1000	1030	1060	1085	1115	1145	1170
6,200	BHP	1.70	1.83	1.94	2.06	2.17	2.30	2.44	2.58	2.73	2.87	3.02	3.14	3.28	3.40	3.54	3.66
	Discrete Spd Setting	B	A	A	A	A	A	A	A	A	C	C	C	C	C	C	C
	RPM	720	760	795	830	865	895	925	955	985	1015	1045	1070	1100	1125	1155	1180
6,400	BHP	1.88	2.02	2.16	2.28	2.42	2.54	2.66	2.78	2.90	3.04	3.16	3.31	3.43	3.58	3.72	3.86
	Discrete Spd Setting	B	A	A	A	A	A	A	A	C	C	C	C	C	C	C	C
	RPM	745	780	815	845	880	910	940	970	1000	1030	1055	1085	1110	1140	1165	1190
6,600	BHP	2.06	2.18	2.32	2.46	2.58	2.70	2.82	2.94	3.07	3.19	3.34	3.46	3.60	3.74	3.88	4.02
	Discrete Spd Setting	A	A	A	A	A	A	A	A	C	C	C	C	C	C	C	C
	RPM	765	795	830	865	895	925	955	985	1015	1040	1070	1095	1125	1150	1175	1200
6,800	BHP	2.22	2.36	2.50	2.62	2.74	2.86	3.00	3.10	3.27	3.41	3.58	3.72	3.85	3.97	4.11	4.23
	Discrete Spd Setting	A	A	A	A	A	A	A	A	C	C	C	C	C	C	C	C
	RPM	780	815	850	880	910	940	970	1000	1030	1055	1085	1110	1135	1160	1190	1215

Notes:

- Motor Sheave set to 1-turn open from factory.
- Factory torque setting is A. Torque setting is field-adjustable to any torque setting listed in drive table through the Wireless Service Tool.
- The unit can control the blower through LAT control. Enable this setting in the field with the Wireless Service Tool.
- The maximum allowable altitude of installation for this product is 6,561 ft (2,000 m).

Table continued on next page.

Blower Performance MB192 with VFD

Models:
MB
072-300

Table continued from previous page

SCFM	ESP (in.w.c.)	0.00	0.10	0.20	0.30	0.40	0.50	0.60	0.70	0.80	0.90	1.00	1.10	1.20	1.30	1.40	1.50	
7,000	BHP	2.40	2.54	2.66	2.80	2.92	3.04	3.14	3.27	3.39	3.54	3.66	3.78	3.96	4.12	4.28	4.44	
	Discrete Spd Setting	A	A	A	A	A	A	A	C	C	C	C	C	C	C	C	C	
	RPM	800	835	865	900	930	960	985	1015	1040	1070	1095	1120	1150	1175	1200	1225	
7,200	BHP	2.58	2.70	2.85	2.99	3.14	3.28	3.42	3.54	3.66	3.81	3.93	4.06	4.22	4.38	4.54	4.70	
	Discrete Spd Setting	A	A	A	A	A	A	C	C	C	C	C	C	C	C	C	C	
	RPM	820	850	885	915	945	975	1005	1030	1055	1085	1110	1135	1160	1185	1210	1235	
7,400	BHP	2.76	2.88	3.02	3.16	3.31	3.45	3.61	3.75	3.92	4.06	4.20	4.36	4.52	4.68	4.81	4.97	
	Discrete Spd Setting	A	A	A	A	A	A	C	C	C	C	C	C	C	C	C	C	
	RPM	840	870	900	930	960	990	1020	1045	1075	1100	1125	1150	1175	1200	1220	1245	
7,600	BHP	2.94	3.07	3.22	3.36	3.50	3.63	3.82	3.98	4.14	4.34	4.50	4.66	4.78	4.94			
	Discrete Spd Setting	A	D	D	D	D	C	C	C	C	C	C	C	C	C			
	RPM	860	890	920	950	980	1005	1035	1060	1085	1115	1140	1165	1185	1210			
7,800	BHP	3.22	3.34	3.49	3.63	3.78	3.96	4.12	4.28	4.44	4.63	4.76	4.92					
	Discrete Spd Setting	A	A	A	A	A	C	C	C	C	C	C	C					
	RPM	880	905	935	965	995	1025	1050	1075	1100	1130	1150	1175					
8,000	BHP	3.41	3.58	3.75	3.92	4.06	4.26	4.42	4.58	4.74	4.90							
	Discrete Spd Setting	A	A	A	A	C	C	C	C	C	C							
	RPM	895	925	955	985	1010	1040	1065	1090	1115	1140							

Notes:

- Motor Sheave set to 1-turn open from factory.
- Factory torque setting is A. Torque setting is field-adjustable to any torque setting listed in drive table through the Wireless Service Tool.
- The unit can control the blower through LAT control. Enable this setting in the field with the Wireless Service Tool.
- The maximum allowable altitude of installation for this product is 6,561 ft (2,000 m).

Blower Performance MB240

Models:
MB
072-300

SCFM	ESP (in.w.c.)	0.00	0.10	0.20	0.30	0.40	0.50	0.60	0.70	0.80	0.90	1.00	1.10	1.20	1.30	1.40	1.50
6,000	BHP				1.78	1.89	2.00	2.12	2.24	2.36	2.48	2.60	2.74	2.89	3.01	3.15	3.30
	Sheave/Mtr				B	B	B	A	A	A	A	A	A	A	A	C	C
	RPM				775	810	845	880	910	940	970	1000	1030	1060	1085	1115	1145
6,200	BHP			1.82	1.93	2.04	2.15	2.30	2.44	2.58	2.73	2.87	2.99	3.14	3.26	3.40	3.52
	Sheave/Mtr			B	B	B	B	A	A	A	A	A	A	A	C	C	C
	RPM			755	790	825	860	895	925	955	985	1015	1040	1070	1095	1125	1150
6,400	BHP			2.00	2.14	2.26	2.40	2.52	2.64	2.76	2.88	3.02	3.14	3.28	3.40	3.56	3.70
	Sheave/Mtr			B	B	B	B	A	A	A	A	A	A	A	C	C	C
	RPM			775	810	840	875	905	935	965	995	1025	1050	1080	1105	1135	1160
6,600	BHP		2.02	2.16	2.30	2.42	2.56	2.68	2.80	2.92	3.05	3.17	3.29	3.43	3.55	3.71	3.85
	Sheave/Mtr		B	B	B	B	A	A	A	A	A	A	A	A	C	C	C
	RPM		755	790	825	855	890	920	950	980	1010	1035	1060	1090	1115	1145	1170
6,800	BHP		2.18	2.32	2.46	2.58	2.70	2.84	2.94	3.06	3.21	3.35	3.52	3.66	3.82	3.94	4.06
	Sheave/Mtr		B	B	B	B	A	A	A	A	A	A	A	C	C	C	C
	RPM		770	805	840	870	900	935	960	990	1020	1045	1075	1100	1130	1155	1180
7,000	BHP	2.22	2.34	2.48	2.62	2.74	2.86	2.98	3.10	3.22	3.34	3.49	3.61	3.73	3.90	4.06	4.22
	Sheave/Mtr	B	B	B	B	A	A	A	A	A	A	A	A	C	C	C	C
	RPM	755	785	820	855	885	915	945	975	1005	1030	1060	1085	1110	1140	1165	1190
7,200	BHP	2.38	2.52	2.64	2.78	2.92	3.06	3.21	3.35	3.47	3.62	3.74	3.88	4.00	4.16	4.32	4.48
	Sheave/Mtr	B	B	B	B	A	A	A	A	A	A	A	C	C	C	C	C
	RPM	770	805	835	870	900	930	960	990	1015	1045	1070	1100	1125	1150	1175	1200
7,400	BHP	2.56	2.68	2.82	2.95	3.09	3.24	3.38	3.53	3.67	3.84	3.98	4.12	4.26	4.42	4.58	4.74
	Sheave/Mtr	B	B	B	A	A	A	A	A	A	A	A	C	C	C	C	C
	RPM	790	820	855	885	915	945	975	1005	1030	1060	1085	1110	1135	1160	1185	1210
7,600	BHP	2.74	2.86	2.98	3.12	3.26	3.41	3.55	3.70	3.89	4.05	4.21	4.40	4.53	4.69	4.85	
	Sheave/Mtr	B	B	B	A	A	A	A	A	A	A	C	C	C	C	C	
	RPM	810	840	870	900	930	960	990	1015	1045	1070	1095	1125	1145	1170	1195	
7,800	BHP	2.98	3.13	3.25	3.39	3.54	3.68	3.83	3.99	4.15	4.34	4.50	4.66	4.82	4.95		
	Sheave/Mtr	B	B	A	A	A	A	A	A	A	C	C	C	C	C		
	RPM	830	860	885	915	945	975	1005	1030	1055	1085	1110	1135	1160	1180		
8,000	BHP	3.18	3.30	3.44	3.61	3.78	3.94	4.10	4.29	4.45	4.61	4.77	4.93				
	Sheave/Mtr	B	B	A	A	A	A	A	A	A	C	C	C				
	RPM	850	875	900	930	960	990	1015	1045	1070	1095	1120	1145				
8,200	BHP	3.35	3.48	3.65	3.79	3.96	4.13	4.27	4.44	4.58	4.72	4.88					
	Sheave/Mtr	B	A	A	A	A	A	A	A	A	C	C					
	RPM	865	890	920	945	975	1005	1030	1060	1085	1110	1135					

Notes:

- A, 1 = Standard RPM/Standard Blower Motor
- E, 5 = High RPM/Large Blower Motor
- The maximum allowable altitude of installation for this product is 6,561 ft (2,000 m).

Table continued on next page.

Blower Performance MB240

Models:
MB
072-300

Table continued from previous page

SCFM	ESP (in.w.c.)	0.00	0.10	0.20	0.30	0.40	0.50	0.60	0.70	0.80	0.90	1.00	1.10	1.20	1.30	1.40	1.50
8,400	BHP	3.62	3.74	3.89	4.03	4.18	4.33	4.49	4.65	4.81	4.97						
	Sheave/Mtr	A	A	A	A	A	A	A	A	C	C						
	RPM	880	905	935	965	995	1020	1045	1070	1095	1120						
8,600	BHP	3.81	3.98	4.12	4.29	4.46	4.62	4.78	4.94								
	Sheave/Mtr	A	A	A	A	A	A	A	A								
	RPM	895	925	950	980	1010	1035	1060	1085								
8,800	BHP	4.06	4.22	4.41	4.57	4.73	4.92										
	Sheave/Mtr	A	A	A	A	A	A										
	RPM	915	940	970	995	1020	1050										
9,000	BHP	4.38	4.54	4.70	4.86												
	Sheave/Mtr	A	A	A	A												
	RPM	935	960	985	1010												
9,200	BHP	4.65	4.76	4.90													
	Sheave/Mtr	A	A	A													
	RPM	955	975	1000													
9,400	BHP	4.83	4.94														
	Sheave/Mtr	A	A														
	RPM	970	990														
9,600	BHP																
	Sheave/Mtr																
	RPM																

Notes:

- A, 1 = Standard RPM/Standard Blower Motor
- E, 5 = High RPM/Large Blower Motor
- The maximum allowable altitude of installation for this product is 6,561 ft (2,000 m).

Blower Performance MB240 with VFD

Models:
MB
072-300

SCFM	ESP (in.w.c.)	0.00	0.10	0.20	0.30	0.40	0.50	0.60	0.70	0.80	0.90	1.00	1.10	1.20	1.30	1.40	1.50
6,000	BHP				1.78	1.89	2.00	2.12	2.24	2.36	2.48	2.60	2.74	2.89	3.01	3.15	3.30
	Discrete Spd Setting				B	B	B	A	A	A	A	A	A	A	A	C	C
	RPM				775	810	845	880	910	940	970	1000	1030	1060	1085	1115	1145
6,200	BHP			1.82	1.93	2.04	2.15	2.30	2.44	2.58	2.73	2.87	2.99	3.14	3.26	3.40	3.52
	Discrete Spd Setting			B	B	B	B	A	A	A	A	A	A	A	C	C	C
	RPM			755	790	825	860	895	925	955	985	1015	1040	1070	1095	1125	1150
6,400	BHP			2.00	2.14	2.26	2.40	2.52	2.64	2.76	2.88	3.02	3.14	3.28	3.40	3.56	3.70
	Discrete Spd Setting			B	B	B	B	A	A	A	A	A	A	A	C	C	C
	RPM			775	810	840	875	905	935	965	995	1025	1050	1080	1105	1135	1160
6,600	BHP		2.02	2.16	2.30	2.42	2.56	2.68	2.80	2.92	3.05	3.17	3.29	3.43	3.55	3.71	3.85
	Discrete Spd Setting		B	B	B	B	A	A	A	A	A	A	A	A	C	C	C
	RPM		755	790	825	855	890	920	950	980	1010	1035	1060	1090	1115	1145	1170
6,800	BHP		2.18	2.32	2.46	2.58	2.70	2.84	2.94	3.06	3.21	3.35	3.52	3.66	3.82	3.94	4.06
	Discrete Spd Setting		B	B	B	B	A	A	A	A	A	A	A	C	C	C	C
	RPM		770	805	840	870	900	935	960	990	1020	1045	1075	1100	1130	1155	1180
7,000	BHP	2.22	2.34	2.48	2.62	2.74	2.86	2.98	3.10	3.22	3.34	3.49	3.61	3.73	3.90	4.06	4.22
	Discrete Spd Setting	B	B	B	B	A	A	A	A	A	A	A	A	C	C	C	C
	RPM	755	785	820	855	885	915	945	975	1005	1030	1060	1085	1110	1140	1165	1190
7,200	BHP	2.38	2.52	2.64	2.78	2.92	3.06	3.21	3.35	3.47	3.62	3.74	3.88	4.00	4.16	4.32	4.48
	Discrete Spd Setting	B	B	B	B	A	A	A	A	A	A	A	C	C	C	C	C
	RPM	770	805	835	870	900	930	960	990	1015	1045	1070	1100	1125	1150	1175	1200
7,400	BHP	2.56	2.68	2.82	2.95	3.09	3.24	3.38	3.53	3.67	3.84	3.98	4.12	4.26	4.42	4.58	4.74
	Discrete Spd Setting	B	B	B	A	A	A	A	A	A	A	A	C	C	C	C	C
	RPM	790	820	855	885	915	945	975	1005	1030	1060	1085	1110	1135	1160	1185	1210
7,600	BHP	2.74	2.86	2.98	3.12	3.26	3.41	3.55	3.70	3.89	4.05	4.21	4.40	4.53	4.69	4.85	5.01
	Discrete Spd Setting	B	B	B	A	A	A	A	A	A	A	C	C	C	C	C	C
	RPM	810	840	870	900	930	960	990	1015	1045	1070	1095	1125	1145	1170	1195	1220
7,800	BHP	2.98	3.13	3.25	3.39	3.54	3.68	3.83	3.99	4.15	4.34	4.50	4.66	4.82	4.95	5.11	5.27
	Discrete Spd Setting	B	B	A	A	A	A	A	A	A	C	C	C	C	C	C	C
	RPM	830	860	885	915	945	975	1005	1030	1055	1085	1110	1135	1160	1180	1205	1230
8,000	BHP	3.18	3.30	3.44	3.61	3.78	3.94	4.10	4.29	4.45	4.61	4.77	4.93	5.09	5.25	5.38	5.54
	Discrete Spd Setting	B	B	A	A	A	A	A	A	A	C	C	C	C	C	C	C
	RPM	850	875	900	930	960	990	1015	1045	1070	1095	1120	1145	1170	1195	1215	1240

Notes:

- Motor Sheave set to 1-turn open from factory.
- Factory torque setting is A. Torque setting is field-adjustable to any torque setting listed in drive table through the Wireless Service Tool.
- The unit can control the blower through LAT control. Enable this setting in the field with the Wireless Service Tool.
- The maximum allowable altitude of installation for this product is 6,561 ft (2,000 m).

Table continued on next page.

Blower Performance MB240 with VFD

Models:
MB
072-300

Table continued from previous page

SCFM	ESP (in.w.c.)	0.00	0.10	0.20	0.30	0.40	0.50	0.60	0.70	0.80	0.90	1.00	1.10	1.20	1.30	1.40	1.50
8,200	BHP	3.35	3.48	3.65	3.79	3.96	4.13	4.27	4.44	4.58	4.72	4.88	5.08	5.24	5.44	5.64	
	Discrete Spd Setting	B	A	A	A	A	A	A	A	A	C	C	C	C	C	C	
	RPM	865	890	920	945	975	1005	1030	1060	1085	1110	1135	1160	1180	1205	1230	
8,400	BHP	3.62	3.74	3.89	4.03	4.18	4.33	4.49	4.65	4.81	4.97	5.16	5.36	5.56	5.72	5.92	
	Discrete Spd Setting	A	A	A	A	A	A	A	A	C	C	C	C	C	C	C	
	RPM	880	905	935	965	995	1020	1045	1070	1095	1120	1145	1170	1195	1215	1240	
8,600	BHP	3.81	3.98	4.12	4.29	4.46	4.62	4.78	4.94	5.10	5.28	5.48	5.64	5.84	6.04	6.20	
	Discrete Spd Setting	A	A	A	A	A	A	A	A	C	C	C	C	C	C	C	
	RPM	895	925	950	980	1010	1035	1060	1085	1110	1135	1160	1180	1205	1230	1250	
8,800	BHP	4.06	4.22	4.41	4.57	4.73	4.92	5.08	5.24	5.40	5.60	5.76	5.96	6.16	6.32		
	Discrete Spd Setting	A	A	A	A	A	A	A	C	C	C	C	C	C	C		
	RPM	915	940	970	995	1020	1050	1075	1100	1125	1150	1170	1195	1220	1240		
9,000	BHP	4.38	4.54	4.70	4.86	5.02	5.18	5.34	5.50	5.68	5.88	6.08	6.24				
	Sheave/Mtr	A	A	A	A	A	A	A	C	C	C	C	C				
	RPM	935	960	985	1010	1035	1060	1085	1110	1135	1160	1185	1205				
	Turns Open	4.5	4	3.5	3	2	1.5	1	3.5	3	2.5	2	1.5				
9,200	BHP	4.65	4.76	4.90	5.08	5.26	5.44	5.62	5.80	6.00	6.16						
	Discrete Spd Setting	A	A	A	A	A	A	C	C	C	C						
	RPM	955	975	1000	1025	1050	1075	1100	1125	1150	1170						
9,400	BHP	4.83	4.94	5.12	5.32	5.52	5.72	5.92	6.12	6.32	6.48						
	Discrete Spd Setting	A	A	A	A	A	A	C	C	C	C						
	RPM	970	990	1015	1040	1065	1090	1115	1140	1165	1185						
9,600	BHP	5.10	5.24	5.44	5.64	5.84	6.04	6.24	6.40								
	Discrete Spd Setting	A	A	A	A	A	C	C	C								
	RPM	985	1005	1030	1055	1080	1105	1130	1150								

Notes:

- Motor Sheave set to 1-turn open from factory.
- Factory torque setting is A. Torque setting is field-adjustable to any torque setting listed in drive table through the Wireless Service Tool.
- The unit can control the blower through LAT control. Enable this setting in the field with the Wireless Service Tool.
- The maximum allowable altitude of installation for this product is 6,561 ft (2,000 m).

Blower Performance MB300

Models:
MB
072-300

SCFM	ESP (in.w.c.)	0.00	0.10	0.20	0.30	0.40	0.50	0.60	0.70	0.80	0.90	1.00	1.10	1.20	1.30	1.40	1.50
8,100	RPM	935	965	995	1025	1055	1085	1115	1145	1170	1195	1220	1245	1265	1285	1310	1330
8,400	BHP	3.36	3.52	3.74	3.92	4.14	4.36	4.57	4.75	4.93	5.11	5.29	5.47	5.62	5.80	5.94	6.12
	Sheave/Mtr	B	B	A	A	A	A	A	A	A	A	A	C	C	C	C	C
8,700	RPM	955	985	1020	1045	1075	1105	1135	1160	1185	1210	1235	1260	1280	1305	1325	1350
	BHP	3.60	3.79	4.00	4.22	4.43	4.65	4.83	5.01	5.19	5.37	5.55	5.76	5.97	6.14	6.35	6.56
	Sheave/Mtr	B	A	A	A	A	A	A	A	A	A	C	C	C	C	C	C
9,000	RPM	975	1005	1035	1065	1095	1125	1150	1175	1200	1225	1250	1275	1300	1320	1345	1370
	BHP	3.90	4.12	4.30	4.51	4.73	4.91	5.09	5.30	5.48	5.66	5.89	6.08	6.32	6.56	6.76	
	Sheave/Mtr	A	A	A	A	A	A	A	A	A	C	C	C	C	C	C	C
9,300	RPM	1000	1030	1055	1085	1115	1140	1165	1195	1220	1245	1270	1290	1315	1340	1360	
	BHP	4.34	4.56	4.74	4.96	5.14	5.35	5.53	5.71	5.89	6.08	6.29	6.50	6.67	6.88	7.05	
	Sheave/Mtr	A	A	A	A	A	A	A	A	A	C	C	C	C	C	C	C
9,600	RPM	1020	1050	1075	1105	1130	1160	1185	1210	1235	1260	1285	1310	1330	1355	1375	
	BHP	4.64	4.85	5.03	5.25	5.46	5.67	5.88	6.13	6.34	6.52	6.66	6.84	7.02	7.16		
	Sheave/Mtr	A	A	A	A	A	A	A	A	C	C	C	C	C	C		
9,900	RPM	1040	1070	1095	1125	1150	1175	1200	1230	1255	1280	1300	1325	1350	1370		
	BHP	4.93	5.15	5.33	5.53	5.78	5.99	6.20	6.41	6.62	6.83	7.04	7.21	7.42			
	Sheave/Mtr	A	A	A	A	A	A	A	C	C	C	C	C	C			
10,200	RPM	1060	1090	1115	1140	1170	1195	1220	1245	1270	1295	1320	1340	1365			
	BHP	5.36	5.57	5.77	5.95	6.17	6.35	6.53	6.74	6.94	7.18	7.42	7.61				
	Sheave/Mtr	A	A	A	A	A	A	C	C	C	C	C	E				
10,500	RPM	1085	1110	1135	1160	1190	1215	1240	1265	1285	1310	1335	1355				
	BHP	5.52	5.75	5.99	6.23	6.47	6.71	6.95	7.19	7.43	7.62	7.86	8.10				
	Sheave/Mtr	A	A	A	A	A	A	C	C	C	E	E	E				
10,800	RPM	1100	1130	1155	1180	1205	1230	1255	1280	1305	1325	1350	1375				
	BHP	6.00	6.24	6.48	6.72	6.96	7.20	7.39	7.63	7.87	8.11	8.30					
	Sheave/Mtr	A	A	A	A	A	C	C	E	E	E	E					
	RPM	1125	1150	1175	1200	1225	1250	1270	1295	1320	1345	1365					

Notes:

- A, 1 = Standard RPM/Standard Blower Motor
- E, 5 = High RPM/Large Blower Motor
- The maximum allowable altitude of installation for this product is 6,561 ft (2,000 m).

Blower Performance MB300 with VFD

Models:
MB
072-300

SCFM	ESP (in.w.c.)	0.00	0.10	0.20	0.30	0.40	0.50	0.60	0.70	0.80	0.90	1.00	1.10	1.20	1.30	1.40	1.50
7,500	BHP	2.69	2.84	2.96	3.11	3.27	3.45	3.60	3.78	3.96	4.08	4.23	4.38	4.53	4.69	4.86	5.03
	Discrete Spd Setting	B	B	B	B	A	A	A	A	A	A	A	A	A	C	C	C
	RPM	890	925	955	990	1020	1050	1075	1105	1135	1155	1180	1205	1230	1255	1275	1295
7,800	BHP	2.87	3.04	3.18	3.36	3.54	3.72	3.87	4.05	4.20	4.35	4.50	4.65	4.80	4.97	5.14	5.30
	Discrete Spd Setting	B	B	B	A	A	A	A	A	A	A	A	A	C	C	C	C
	RPM	910	945	975	1010	1040	1070	1095	1125	1150	1175	1200	1225	1250	1270	1290	1310
8,100	BHP	3.10	3.26	3.42	3.60	3.78	3.96	4.14	4.34	4.52	4.70	4.88	5.06	5.21	5.35	5.53	5.68
	Discrete Spd Setting	B	B	B	A	A	A	A	A	A	A	A	C	C	C	C	C
	RPM	935	965	995	1025	1055	1085	1115	1145	1170	1195	1220	1245	1265	1285	1310	1330
8,400	BHP	3.36	3.52	3.74	3.92	4.14	4.36	4.57	4.75	4.93	5.11	5.29	5.47	5.62	5.80	5.94	6.12
	Discrete Spd Setting	B	B	A	A	A	A	A	A	A	A	A	C	C	C	C	C
	RPM	955	985	1020	1045	1075	1105	1135	1160	1185	1210	1235	1260	1280	1305	1325	1350
8,700	BHP	3.60	3.79	4.00	4.22	4.43	4.65	4.83	5.01	5.19	5.37	5.55	5.76	5.97	6.14	6.35	6.56
	Discrete Spd Setting	B	A	A	A	A	A	A	A	A	A	C	C	C	C	C	C
	RPM	975	1005	1035	1065	1095	1125	1150	1175	1200	1225	1250	1275	1300	1320	1345	1370
9,000	BHP	3.90	4.12	4.30	4.51	4.73	4.91	5.09	5.30	5.48	5.66	5.89	6.08	6.32	6.56	6.76	
	Discrete Spd Setting	A	A	A	A	A	A	A	A	A	C	C	C	C	C	C	
	RPM	1000	1030	1055	1085	1115	1140	1165	1195	1220	1245	1270	1290	1315	1340	1360	
9,300	BHP	4.34	4.56	4.74	4.96	5.14	5.35	5.53	5.71	5.89	6.08	6.29	6.50	6.67	6.88	7.05	
	Discrete Spd Setting	A	A	A	A	A	A	A	A	A	C	C	C	C	C	C	
	RPM	1020	1050	1075	1105	1130	1160	1185	1210	1235	1260	1285	1310	1330	1355	1375	
9,600	BHP	4.64	4.85	5.03	5.25	5.46	5.67	5.88	6.13	6.34	6.52	6.66	6.84	7.02	7.16		
	Discrete Spd Setting	A	A	A	A	A	A	A	A	C	C	C	C	C	C		
	RPM	1040	1070	1095	1125	1150	1175	1200	1230	1255	1280	1300	1325	1350	1370		
9,900	BHP	4.93	5.15	5.33	5.53	5.78	5.99	6.20	6.41	6.62	6.83	7.04	7.21	7.42			
	Discrete Spd Setting	A	A	A	A	A	A	A	C	C	C	C	C	C			
	RPM	1060	1090	1115	1140	1170	1195	1220	1245	1270	1295	1320	1340	1365			
10,200	BHP	5.36	5.57	5.77	5.95	6.17	6.35	6.53	6.74	6.94	7.18						
	Discrete Spd Setting	A	A	A	A	A	A	C	C	C	C						
	RPM	1085	1110	1135	1160	1190	1215	1240	1265	1285	1310						
10,500	BHP	5.52	5.75	5.99	6.23	6.47	6.71	6.95	7.19								
	Discrete Spd Setting	A	A	A	A	A	A	C	C								
	RPM	1100	1130	1155	1180	1205	1230	1255	1280								
10,800	BHP	6.00	6.24	6.48	6.72	6.96	7.20	7.39	7.63								
	Discrete Spd Setting	A	A	A	A	A	C	C	C								
	RPM	1125	1150	1175	1200	1225	1250	1270	1295								

Notes:

- Motor Sheave set to 1-turn open from factory.
- Factory torque setting is A. Torque setting is field-adjustable to any torque setting listed in drive table through the Wireless Service Tool
- The unit can control the blower through LAT control. Enable this setting in the field with the Wireless Service Tool.
- The maximum allowable altitude of installation for this product is 6,561 ft (2,000 m).

Electrical Data Standard

Models:
MB
072-300

Model	Voltage Code	Voltage	Min/Max Voltage	Blower Option	Compressor			Fan Motor FLA	Rated Current Amps	Min Circuit Amps	SCCR kA RMS Symetrical	SCCR Volts Maximum	Max Fuse HACR Amps
					Qty	RLA	LRA						
MB072	K	208/230-3-60	187/252	1,2,3	2	12.2	97.5	3.0	27.4	30.5	5	600	40
				4,5	2	12.2	97.5	5.8	30.2	33.3	5	600	45
				6	2	12.2	97.5	6.0	30.4	33.5	5	600	45
	L	460-3-60	432/504	1,2,3	2	5.8	44.3	1.4	13.0	14.5	5	600	20
				4,5	2	5.8	44.3	2.9	14.5	16.0	5	600	20
				6	2	5.8	44.3	4.6	16.2	17.7	5	600	20
	M	575-3-60	540/630	1,2,3	2	4.5	27.1	1.2	10.2	11.3	5	600	15
				4,5	2	4.5	27.1	2.2	11.2	12.3	5	600	15
	MB096	K	208/230-3-60	187/252	1,2,3	2	12.8	120.4	5.8	31.4	34.6	5	600
4,5					2	12.8	120.4	8.2	33.8	37.0	5	600	45
6					2	12.8	120.4	16.0	41.6	45.6	5	600	60
L		460-3-60	432/504	1,2,3	2	6.0	49.4	2.9	14.9	16.4	5	600	20
				4,5	2	6.0	49.4	4.1	16.1	17.6	5	600	20
				6	2	6.0	49.4	6.9	18.9	20.6	5	600	25
M		575-3-60	540/630	1,2,3	2	5.8	41.0	2.2	13.8	15.3	5	600	20
				4,5	2	5.8	41.0	3.2	14.8	16.3	5	600	20
MB120		K	208/230-3-60	187/252	1,2,3	2	18.6	155.0	8.2	45.4	50.1	5	600
	4,5				2	18.6	155.0	14.0	51.2	55.9	5	600	70
	6				2	18.6	155.0	20.3	57.5	62.6	5	600	80
	L	460-3-60	432/504	1,2,3	2	8.3	58.1	4.1	20.7	22.8	5	600	30
				4,5	2	8.3	58.1	6.5	23.1	25.2	5	600	30
				6	2	8.3	58.1	10.3	26.9	29.5	5	600	35
	M	575-3-60	540/630	1,2,3	2	7.7	47.8	3.2	18.6	20.5	5	600	25
				4,5	2	7.7	47.8	5.2	20.6	22.5	5	600	30
	MB168	K	208/230-3-60	187/252	1,2,3	2	24.4	200.0	8.2	57.0	63.1	5	600
4,5					2	24.4	200.0	14.0	62.8	68.9	5	600	90
6					2	24.4	200.0	10.0	58.8	64.9	5	600	80
L		460-3-60	432/504	1,2,3	2	11.9	103.0	4.1	27.9	30.9	5	600	40
				4,5	2	11.9	103.0	6.5	30.3	33.3	5	600	45
				6	2	11.9	103.0	10.3	34.1	37.1	5	600	45
M		575-3-60	540/630	1,2,3	2	9.4	78.0	3.2	22.0	24.4	5	600	30
				4,5	2	9.4	78.0	5.2	24.0	26.4	5	600	35

Table continued on next page.

Table continued from previous page

Model	Voltage Code	Voltage	Min/Max Voltage	Blower Option	Compressor			Fan Motor FLA	Rated Current Amps	Min Circuit Amps	SCCR kA RMS Symetrical	SCCR Volts Maximum	Max Fuse HACR Amps
					Qty	RLA	LRA						
MB192	K	208/230-3-60	187/252	1,2,3	2	27.7	178.5	8.2	63.6	70.5	5	600	90
				4,5	2	27.7	178.5	14.0	69.4	76.3	5	600	100
				6	2	27.7	178.5	20.3	75.7	82.6	5	600	110
	L	460-3-60	432/504	1,2,3	2	11.5	103.0	4.1	27.1	30.0	5	600	40
				4,5	2	11.5	103.0	6.5	29.5	32.4	5	600	40
				6	2	11.5	103.0	10.3	33.3	36.2	5	600	45
	M	575-3-60	540/630	1,2,3	2	9.0	78.0	3.2	21.2	23.5	5	600	30
				4,5	2	9.0	78.0	5.2	23.2	25.5	5	600	30
	MB240	K	208/230-3-60	187/252	1,2,3	2	28.5	255.0	14.0	71.0	78.1	5	600
4,5					2	28.5	255.0	20.6	77.6	84.7	5	600	110
6					2	28.5	255.0	30.5	87.5	95.1	5	600	125
L		460-3-60	432/504	1,2,3	2	13.5	123.0	6.5	33.5	36.9	5	600	50
				4,5	2	13.5	123.0	9.8	36.8	40.2	5	600	50
				6	2	13.5	123.0	14.8	41.8	45.5	5	600	60
M		575-3-60	540/630	1,2,3	2	10.7	93.7	5.2	26.6	29.3	5	600	35
				4,5	2	10.7	93.7	8.0	29.4	32.1	5	600	40
MB300		K	208/230-3-60	187/252	1,2,3	2	40.8	270.0	20.6	102.2	112.4	5	600
	4,5				2	40.8	270.0	26.8	108.4	118.6	5	600	150
	6				2	40.8	270.0	25.0	106.6	116.8	5	600	150
	L	460-3-60	432/504	1,2,3	2	19.4	147.0	9.8	48.6	53.5	5	600	70
				4,5	2	19.4	147.0	12.7	51.5	56.4	5	600	70
				6	2	19.4	147.0	20.3	59.1	64.2	5	600	80
	M	575-3-60	540/630	1,2,3	2	13.7	109.0	8.0	35.4	38.8	5	600	50
				4,5	2	13.7	109.0	10.0	37.4	40.8	5	600	50

Electrical Data Dual Point Power

Models:
MB
072-300

Model	Voltage Code	Voltage	Min/Max Voltage	Blower Option	Compressor Power Supply							Fan Power Supply					
					Qty	RLA	LRA	Rated Current Amps	Min Circuit Amps	SCCR kA RMS Symmetrical	SCCR Volts Max	Max Fuse HACR Amps	Fan Motor FLA	Min Circuit Amps	SCCR kA RMS Symmetrical	SCCR Volts Max	Max Fuse HACR Amps
MB072	K	208/230-3-60	187/252	A,B,C	2	12.2	97.5	24.4	27.5	5	600	35	3.0	3.8	5	600	15
				D,E	2	12.2	97.5	24.4	27.5	5	600	35	5.8	7.3	5	600	15
				F	2	12.2	97.5	24.4	27.5	5	600	35	6.0	7.5	5	600	15
	L	460-3-60	432/504	A,B,C	2	5.8	44.3	11.6	13.1	5	600	15	1.4	1.8	5	600	15
				D,E	2	5.8	44.3	11.6	13.1	5	600	15	2.9	3.6	5	600	15
				F	2	5.8	44.3	11.6	13.1	5	600	15	4.6	5.8	5	600	15
	M	575-3-60	540/630	A,B,C	2	4.5	27.1	9.0	10.1	5	600	15	1.2	1.5	5	600	15
				D,E	2	4.5	27.1	9.0	10.1	5	600	15	2.2	2.8	5	600	15
	MB096	K	208/230-3-60	187/252	A,B,C	2	12.8	120.4	25.6	28.8	5	600	40	5.8	7.3	5	600
D,E					2	12.8	120.4	25.6	28.8	5	600	40	8.2	10.3	5	600	15
F					2	12.8	120.4	25.6	28.8	5	600	40	16.0	20.0	5	600	35
L		460-3-60	432/504	A,B,C	2	6.0	49.4	12.0	13.5	5	600	15	2.9	3.6	5	600	15
				D,E	2	6.0	49.4	12.0	13.5	5	600	15	4.1	5.1	5	600	15
				F	2	6.0	49.4	12.0	13.5	5	600	15	6.9	8.6	5	600	15
M		575-3-60	540/630	A,B,C	2	5.8	41	11.6	13.1	5	600	15	2.2	2.8	5	600	15
				D,E	2	5.8	41	11.6	13.1	5	600	15	3.2	4.0	5	600	15
MB120		K	208/230-3-60	187/252	A,B,C	2	18.6	155	37.2	41.9	5	600	60	8.2	10.3	5	600
	D,E				2	18.6	155	37.2	41.9	5	600	60	14.0	17.5	5	600	30
	F				2	18.6	155	37.2	41.9	5	600	60	20.3	25.4	5	600	45
	L	460-3-60	432/504	A,B,C	2	8.3	58.1	16.6	18.7	5	600	25	4.1	5.1	5	600	15
				D,E	2	8.3	58.1	16.6	18.7	5	600	25	6.5	8.1	5	600	15
				F	2	8.3	58.1	16.6	18.7	5	600	25	10.3	12.9	5	600	20
	M	575-3-60	540/630	A,B,C	2	7.7	47.8	15.4	17.3	5	600	25	3.2	4.0	5	600	15
				D,E	2	7.7	47.8	15.4	17.3	5	600	25	5.2	6.5	5	600	15

Table continued on next page.

Electrical Data Dual Point Power

Models:
MB
072-300

Table continued from previous page

Model	Voltage Code	Voltage	Min/Max Voltage	Blower Option	Compressor Power Supply							Fan Power Supply					
					Qty	RLA	LRA	Rated Current Amps	Min Circuit Amps	SCCR kA RMS Symmetrical	SCCR Volts Max	Max Fuse HACR Amps	Fan Motor FLA	Min Circuit Amps	SCCR kA RMS Symmetrical	SCCR Volts Max	Max Fuse HACR Amps
MB168	K	208/230-3-60	187/252	A,B,C	2	24.4	200	48.8	54.9	5	600	70	8.2	10.3	5	600	15
				D,E	2	24.4	200	48.8	54.9	5	600	70	14.0	17.5	5	600	30
				F	2	24.4	200	48.8	54.9	5	600	70	10.0	12.5	5	600	20
	L	460-3-60	432/504	A,B,C	2	11.9	103	23.8	26.8	5	600	35	4.1	5.1	5	600	15
				D,E	2	11.9	103	23.8	26.8	5	600	35	6.5	8.1	5	600	15
				F	2	11.9	103	23.8	26.8	5	600	35	10.3	12.9	5	600	20
	M	575-3-60	540/630	A,B,C	2	9.4	78	18.8	21.2	5	600	30	3.2	4.0	5	600	15
				D,E	2	9.4	78	18.8	21.2	5	600	30	5.2	6.5	5	600	15
	MB192	K	208/230-3-60	187/252	A,B,C	2	27.7	178.5	55.4	62.3	5	600	90	8.2	10.3	5	600
D,E					2	27.7	178.5	55.4	62.3	5	600	90	14.0	17.5	5	600	30
F					2	27.7	178.5	55.4	62.3	5	600	90	20.3	25.4	5	600	45
L		460-3-60	432/504	A,B,C	2	11.5	103	23.0	25.9	5	600	35	4.1	5.1	5	600	15
				D,E	2	11.5	103	23.0	25.9	5	600	35	6.5	8.1	5	600	15
				F	2	11.5	103	23.0	25.9	5	600	35	10.3	12.9	5	600	20
M		575-3-60	540/630	A,B,C	2	9.0	78	18.0	20.3	5	600	25	3.2	4.0	5	600	15
				D,E	2	9.0	78	18.0	20.3	5	600	25	5.2	6.5	5	600	15
MB240		K	208/230-3-60	187/252	A,B,C	2	28.5	255	57.0	64.1	5	600	90	14.0	17.5	5	600
	D,E				2	28.5	255	57.0	64.1	5	600	90	20.6	25.8	5	600	45
	F				2	28.5	255	57.0	64.1	5	600	90	30.5	38.1	5	600	60
	L	460-3-60	432/504	A,B,C	2	13.5	123	27.0	30.4	5	600	40	6.5	8.1	5	600	15
				D,E	2	13.5	123	27.0	30.4	5	600	40	9.8	12.3	5	600	20
				F	2	13.5	123	27.0	30.4	5	600	40	14.8	18.5	5	600	30
	M	575-3-60	540/630	A,B,C	2	10.7	93.7	21.4	24.1	5	600	30	5.2	6.5	5	600	15
				D,E	2	10.7	93.7	21.4	24.1	5	600	30	8.0	10.0	5	600	15
	MB300	K	208/230-3-60	187/252	A,B,C	2	40.8	270	81.6	91.8	5	600	125	20.6	25.8	5	600
D,E					2	40.8	270	81.6	91.8	5	600	125	26.8	33.5	5	600	60
F					2	40.8	270	81.6	91.8	5	600	125	25.0	31.3	5	600	50
L		460-3-60	432/504	A,B,C	2	19.4	147	38.8	43.7	5	600	60	9.8	12.3	5	600	20
				D,E	2	19.4	147	38.8	43.7	5	600	60	12.7	15.9	5	600	25
				F	2	19.4	147	38.8	43.7	5	600	60	20.3	25.4	5	600	45
M		575-3-60	540/630	A,B,C	2	13.7	109	27.4	30.8	5	600	40	8.0	10.0	5	600	15
				D,E	2	13.7	109	27.4	30.8	5	600	40	10.0	12.5	5	600	20

MB Physical Data

Standard Range Cabinet										
Configuration	Horizontal			Vertical						
Unit Size	072	096	120	072	096	120	168	192	240	300
Compressor Type	Scroll			Scroll						
Number of Circuits (Compressors)	2			2						
Refrigerant Leak Detection System	R	R	R	R	R	R	R	R	R	R
Number of Sensors	2	2	2	2	2	2	2	2	2	2
Factory Charge R-454B (oz) [kg] per Circuit	54 [1.5]	62 [1.8]	66 [1.9]	54 [1.5]	62 [1.8]	66 [1.9]	94 [2.7]	103 [2.9]	134 [3.8]	184 [5.2]
Blower Motor										
Standard Motor (hp) [kW]	1 [0.75]	2 [1.49]	3 [2.23]	1 [0.75]	2 [1.49]	3 [2.23]		5 [3.73]		7.5 [5.60]
Large Motor ¹ (hp) [kW]	2 [1.49]	3 [2.23]	5 [3.73]	2 [1.49]	3 [2.23]	5 [3.73]		7.5 [5.60]		10 [7.46]
Water Connections										
FPT (in) [mm]	1-1/4" [31.8]		1-1/2" [38.1]	1-1/4" [31.8]		1-1/2" [38.1]	2" [50.8]		2-1/2" [63.5]	
Coax Data										
Number of Coaxes per Circuit	1			1			2		3	
Volume per Coax (gallon) [liter]	1.62 [6.13]	2.40 [9.08]	2.40 [9.08]	1.62 [6.13]	2.40 [9.08]	2.40 [9.08]	3.62 [13.70]	4.83 [18.28]	4.90 [18.55]	7.39 [27.98]
Condensate Connection Size										
FPT (in) [mm]	3/4" [19.1]			1" [25.4]						
Miscellaneous Data										
Filter Standard - 1" [2.54cm] Throwaway (qty) (in) [cm]	(QTY.3) 16 x 20 [40.6 x 50.8]			(QTY.4) 20 x 20 [50.8 x 50.8]			(QTY.4) 20 x 25 [50.80 x 63.5]			
	(QTY.1) 20 x 20 [50.8 x 50.8]						(QTY.2) 20 x 30 [50.80 x 76.2]			
Weight - Operating (lbs) [kg]	586 [265.8]	644 [292.1]	698 [316.6]	586 [265.8]	644 [292.1]	698 [316.6]	1069 [484.9]	1164 [528.0]	1184 [537.1]	1297 [588.3]
Weight - Packaged (lbs) [kg]	626 [283.9]	684 [310.3]	738 [334.8]	626 [283.9]	684 [310.3]	738 [334.8]	1149 [521.2]	1244 [564.3]	1264 [573.3]	1377 [624.6]
Corner Weights - Standard Configuration										
Compressor Section - Left Front (lb) [kg]	101 [46]	120 [52]	137 [62]							
Control Box - Right Front (lb) [kg]	235 [107]	254 [115]	271 [123]							
Air Coil Side - Back (lb) [kg]	70 [32]	80 [36]	90 [41]							
Blower Side - Back (lb) [kg]	180 [82]	190 [86]	200 [91]							
Extended Range Cabinet with Waterside Economizer										
Dimensions										
Standard Weight - Operating (lbs.) [kg]	586 [265.8]	644 [292.1]	698 [316.6]	586 [265.8]	644 [292.1]	698 [316.6]	1,069 [484.9]	1,164 [528.0]	1,184 [537.1]	1,297 [588.3]
Standard Weight - Packaged (lbs.) [kg]	626 [283.9]	684 [310.3]	738 [334.8]	626 [283.9]	684 [310.3]	738 [334.8]	1,149 [521.2]	1,244 [564.3]	1,264 [573.3]	1,377 [624.6]
WSE Unit Weight - Operating (lbs.) [kg]	838 [380.1]	921 [417.7]	998 [452.7]	762 [345.5]	837 [379.7]	907 [411.6]	1,529 [693.4]	1,665 [755]	1,693 [768]	1,855 [841.3]
WSE Unit Weight - Packaged (lbs.) [kg]	900 [408.2]	978 [443.7]	1,008 [457.2]	814 [369.1]	889 [403.3]	962 [436.4]	1,643 [745.3]	1,779 [806.9]	1,808 [819.9]	1,974 [895.4]
Air Coil Volume (gal) [L]	4.0 [15.1]	4.4 [16.7]		4.3 [16.3]	4.8 [18.2]		9.7 [36.7]		19.0 [71.9]	
Corner Weights										
Compressor Section - Left Front (lb) [kg]	154 [70]	169 [77]	183 [83]							
Control Box - Right Front (lb) [kg]	331 [150]	364 [165]	394 [179]							
Air Coil Side - Back (lb) [kg]	104 [47]	115 [52]	124 [56]							
Blower Side - Back (lb) [kg]	249 [113]	273 [124]	296 [134]							

• O = Optional, R = Required
1. VFD Option comes with Large motor option

Unit Maximum Water Working Pressure

Configuration	Max Pressure PSIG [kPa]
Base Unit	300 [2,068]
MWV	300 [2,068]
MOD Valve	300 [2,068]

Use the lowest maximum pressure rating when multiple options are combined.

Waterside Economizer (WSE) Performance Data

Models:
MB
072-300

Unit with WSE Cooling Performance – 45°F EWT, 400 CFM/Ton

Model	Cabinet Config	Water Side			Airside (Dry)		Capacity	
		Flow GPM	PD psi	PD ft	CFM	DP psi	TC	SC
MB072	H	18	3.8	8.7	2,400	<0.10	29,804	17,778
MB096	H	24	6.8	15.6	3,200	<0.10	39,061	22,964
MB120	H	30	6.2	14.3	4,000	<0.10	43,659	24,291
MB072	V	20	2.7	6.3	2,400	<0.10	27,548	16,904
MB096	V	24	4.8	11.0	3,200	<0.10	35,545	21,568
MB120	V	30	3.0	7.0	4,000	<0.10	41,300	24,495
MB168	V	42	4.8	11.0	5,600	<0.10	76,156	45,598
MB192	V	48	5.9	13.5	6,400	<0.10	83,715	49,510
MB240	V	60	15.0	34.6	8,000	0.10	165,124	99,273
MB300	V	75	22.1	51.1	10,000	0.13	189,286	112,711

EAT 80/67; EWT 45; Nominal Airflow at 1.00" ESP; Nominal Waterflow

Airside PD

Model	Cabinet Config	Coil	AirSide PD Adder (in. wg) at CFM/TON				
			300	350	400	450	500
MB072	H	Dry	< 0.1	< 0.1	< 0.1	< 0.1	< 0.1
		Wet	< 0.1	< 0.1	< 0.1	< 0.1	0.10
MB096	H	Dry	< 0.1	< 0.1	< 0.1	< 0.1	< 0.1
		Wet	< 0.1	< 0.1	< 0.1	< 0.1	0.10
MB120	H	Dry	< 0.1	< 0.1	< 0.1	< 0.1	< 0.1
		Wet	< 0.1	< 0.1	< 0.1	< 0.1	0.10
MB072	V	Dry	< 0.1	< 0.1	< 0.1	< 0.1	< 0.1
		Wet	< 0.1	< 0.1	< 0.1	< 0.1	0.10
MB096	V	Dry	< 0.1	< 0.1	< 0.1	< 0.1	< 0.1
		Wet	< 0.1	< 0.1	< 0.1	< 0.1	0.10
MB120	V	Dry	< 0.1	< 0.1	< 0.1	< 0.1	< 0.1
		Wet	< 0.1	< 0.1	< 0.1	< 0.1	0.10
MB168	V	Dry	< 0.1	< 0.1	< 0.1	< 0.1	< 0.1
		Wet	< 0.1	< 0.1	< 0.1	< 0.1	0.10
MB192	V	Dry	< 0.1	< 0.1	< 0.1	< 0.1	< 0.1
		Wet	< 0.1	< 0.1	< 0.1	< 0.1	0.10
MB240	V	Dry	< 0.1	< 0.1	< 0.1	< 0.1	0.12
		Wet	< 0.1	0.11	0.14	0.17	0.20
MB300	V	Dry	< 0.1	< 0.1	< 0.1		
		Wet	< 0.1	0.11	0.14		

WSE Valve Flow Coefficient

Model	Cabinet Config	CV	
		Econ - On	Econ - Off
MB072	H	34	27
MB096	H	61	49
MB120	H	61	49
MB072	V	34	27
MB096	V	61	49
MB120	V	61	49
MB168	V	109	87
MB192	V	109	87
MB240	V	109	87
MB300	V	109	87

Waterside Economizer (WSE) Entering Air Corrections

Models:
MB
072-300

WSE Entering Air Correction tables include the following notes:

- *Sensible Capacity = Total Capacity
- Corrections are based on nominal gpm and cfm.
- Tot Clg Cap @ EAT 80db/67wb
- EWT @ 45°F

MB072 Horizontal Nominal Airflow (cfm) 2,400 Nominal Waterflow (gpm) 18

Ent Air WB (°F)	Total Clg Cap	Sensible Cooling Capacity Multipliers - Entering DB °F								
		65	70	75	80	80.6	85	90	95	100
50.0	0.899	*	*	*	*	*	*	*	*	*
55.0	0.902	*	*	*	*	*	*	*	*	*
60.0	0.905	0.448	0.661	*	*	*	*	*	*	*
65.0	0.872		0.590	0.810	1.031	1.056	1.706	*	*	*
66.2	0.881		0.546	0.900	1.127	1.169	2.171	*	*	*
67.0	1.000		0.562	0.779	1.000	1.106	1.225	1.958	*	*
70.0	1.210			0.737	0.956	1.052	1.178	1.404	1.896	*
75.0	1.579				0.866	0.905	1.086	1.313	1.541	1.778

MB072 Vertical Nominal Airflow (cfm) 2,400 Nominal Waterflow (gpm) 18

Ent Air WB (°F)	Total Clg Cap	Sens Clg Cap Multipliers - Entering DB °F								
		65	70	75	80	80.6	85	90	95	100
50.0	0.922	*	*	*	*	*	*	*	*	*
55.0	0.925	*	*	*	*	*	*	*	*	*
60.0	0.929	0.431	0.667	*	*	*	*	*	*	*
65.0	0.870		0.574	0.803	1.038	1.063	1.700	*	*	*
66.2	0.885		0.538	0.894	1.131	1.174	2.164	*	*	*
67.0	1.000		0.533	0.769	1.000	1.100	1.290	1.951	*	*
70.0	1.196			0.704	0.934	1.020	1.169	1.410	2.109	*
75.0	1.566				0.825	0.854	1.058	1.297	1.536	1.785

MB096 Horizontal Nominal Airflow (cfm) 3,200 Nominal Waterflow (gpm) 24

Ent Air WB (°F)	Total Clg Cap	Sens Clg Cap Multipliers - Entering DB °F								
		65	70	75	80	80.6	85	90	95	100
50.0	0.882	*	*	*	*	*	*	*	*	*
55.0	0.886	*	*	*	*	*	*	*	*	*
60.0	0.889	0.442	0.660	*	*	*	*	*	*	*
65.0	0.868		0.591	0.808	1.027	1.051	1.652	*	*	*
66.2	0.874		0.548	0.896	1.122	1.164	2.127	*	*	*
67.0	1.000		0.560	0.782	1.000	1.107	1.220	1.913	*	*
70.0	1.195			0.729	0.948	1.043	1.173	1.399	1.856	*
75.0	1.571				0.866	0.905	1.086	1.318	1.544	1.773

Waterside Economizer (WSE) Entering Air Corrections

Models:
MB
072-300

MB096 Vertical Nominal Airflow (cfm) 3,200 Nominal Waterflow (gpm) 24

Ent Air WB (°F)	Total Clg Cap	Sens Clg Cap Multipliers - Entering DB °F								
		65	70	75	80	80.6	85	90	95	100
50.0	0.916	*	*	*	*	*	*	*	*	*
55.0	0.919	*	*	*	*	*	*	*	*	*
60.0	0.922	0.433	0.662	*	*	*	*	*	*	*
65.0	0.871		0.568	0.801	1.039	1.064	1.708	*	*	*
66.2	0.884		0.532	0.892	1.133	1.175	2.175	*	*	*
67.0	1.000		0.536	0.766	1.000	1.099	1.272	1.963	*	*
70.0	1.204			0.702	0.939	1.022	1.181	1.421	2.080	*
75.0	1.579				0.831	0.857	1.064	1.311	1.551	1.796

MB120 Horizontal Nominal Airflow (cfm) 4,000 Nominal Waterflow (gpm) 30

Ent Air WB (°F)	Total Clg Cap	Sens Clg Cap Multipliers - Entering DB °F								
		65	70	75	80	80.6	85	90	95	100
50.0	0.867	*	*	*	*	*	*	*	*	*
55.0	0.870	*	*	*	*	*	*	*	*	*
60.0	0.874	0.368	0.615	*	*	*	*	*	*	*
65.0	0.858		0.537	0.782	1.030	1.057	1.708	*	*	*
66.2	0.863		0.490	0.881	1.136	1.182	2.211	*	*	*
67.0	1.000		0.502	0.753	1.000	1.090	1.249	2.000	*	*
70.0	1.209			0.694	0.941	1.018	1.196	1.450	1.952	*
75.0	1.611				0.849	0.874	1.097	1.360	1.614	1.873

MB120 Vertical Nominal Airflow (cfm) 4,000 Nominal Waterflow (gpm) 30

Ent Air WB (°F)	Total Clg Cap	Sens Clg Cap Multipliers - Entering DB °F								
		65	70	75	80	80.6	85	90	95	100
50.0	0.907	*	*	*	*	*	*	*	*	*
55.0	0.910	*	*	*	*	*	*	*	*	*
60.0	0.914	0.403	0.644	*	*	*	*	*	*	*
65.0	0.867		0.546	0.790	1.041	1.067	1.737	*	*	*
66.2	0.879		0.508	0.884	1.138	1.182	2.211	*	*	*
67.0	1.000		0.512	0.754	1.000	1.092	1.279	2.004	*	*
70.0	1.211			0.687	0.936	1.011	1.191	1.443	2.117	*
75.0	1.597				0.823	0.843	1.068	1.328	1.580	1.837

MB0168 Vertical Nominal Airflow (cfm) 5,600 Nominal Waterflow (gpm) 42

Ent Air WB (°F)	Total Clg Cap	Sens Clg Cap Multipliers - Entering DB °F								
		65	70	75	80	80.6	85	90	95	100
50.0	0.884	*	*	*	*	*	*	*	*	*
55.0	0.887	*	*	*	*	*	*	*	*	*
60.0	0.890	0.482	0.680	*	*	*	*	*	*	*
65.0	0.884		0.620	0.820	1.030	1.051	1.559	*	*	*
66.2	0.887		0.577	0.905	1.120	1.157	2.037	*	*	*
67.0	1.000		0.599	0.798	1.000	1.117	1.212	1.797	*	*
70.0	1.195			0.756	0.960	1.067	1.168	1.375	1.739	*
75.0	1.554				0.889	0.937	1.095	1.303	1.511	1.723

Waterside Economizer (WSE) Entering Air Corrections

Models:
MB
072-300

MB192 Vertical Nominal Airflow (cfm) 6,400 Nominal Waterflow (gpm) 48

Ent Air WB (°F)	Total Clg Cap	Sens Clg Cap Multipliers - Entering DB °F								
		65	70	75	80	80.6	85	90	95	100
50.0	0.879	*	*	*	*	*	*	*	*	*
55.0	0.882	*	*	*	*	*	*	*	*	*
60.0	0.885	0.467	0.671	*	*	*	*	*	*	*
65.0	0.882		0.610	0.815	1.031	1.052	1.567	*	*	*
66.2	0.884		0.566	0.902	1.122	1.160	2.051	*	*	*
67.0	1.000		0.588	0.792	1.000	1.114	1.218	1.811	*	*
70.0	1.197			0.749	0.958	1.062	1.173	1.386	1.753	*
75.0	1.563				0.886	0.932	1.098	1.312	1.526	1.743

MB240 Vertical Nominal Airflow (cfm) 8,000 Nominal Waterflow (gpm) 60

Ent Air WB (°F)	Total Clg Cap	Sens Clg Cap Multipliers - Entering DB °F								
		65	70	75	80	80.6	85	90	95	100
50.0	0.858	*	*	*	*	*	*	*	*	*
55.0	0.862	*	*	*	*	*	*	*	*	*
60.0	0.866	0.481	0.680	*	*	*	*	*	*	*
65.0	0.876		0.621	0.824	1.026	1.051	1.556	*	*	*
66.2	0.876		0.584	0.899	1.107	1.146	2.010	*	*	*
67.0	1.000		0.592	0.797	1.000	1.117	1.204	1.786	*	*
70.0	1.191			0.754	0.956	1.063	1.159	1.367	1.730	*
75.0	1.549				0.882	0.930	1.085	1.290	1.494	1.701

MB300 Vertical Nominal Airflow (cfm) 10,000 Nominal Waterflow (gpm) 75

Ent Air WB (°F)	Total Clg Cap	Sens Clg Cap Multipliers - Entering DB °F								
		65	70	75	80	80.6	85	90	95	100
50.0	0.886	*	*	*	*	*	*	*	*	*
55.0	0.890	*	*	*	*	*	*	*	*	*
60.0	0.894	0.477	0.676	*	*	*	*	*	*	*
65.0	0.874		0.623	0.822	1.023	1.047	1.579	*	*	*
66.2	0.880		0.576	0.908	1.119	1.158	2.063	*	*	*
67.0	1.000		0.596	0.800	1.000	1.118	1.202	1.815	*	*
70.0	1.196			0.755	0.961	1.067	1.162	1.368	1.720	*
75.0	1.552				0.888	0.936	1.089	1.293	1.497	1.704

Waterside Economizer (WSE) Cooling Corrections

Models:
MB
072-300

WSE Cooling Correction tables include the following note:

- Corrections based on 80/67; EWT 45; Nominal Airflow @ 1.00" ESP; Nominal Water flow

MB072 Horizontal

Airflow % Normal Capacity	Cooling Corrections	
	Sensible Capacity	Sens/Total Ratio
75.00	0.906	0.61
81.25	0.939	0.61
87.50	0.968	0.60
93.75	0.988	0.60
100.00	1.000	0.60
106.25	1.010	0.59
112.50	1.012	0.58
118.75	1.008	0.58
125.00	0.994	0.57

MB072 Vertical

Airflow % Normal Capacity	Cooling Corrections	
	Sensible Capacity	Sens/Total Ratio
75.00	0.905	0.62
81.25	0.935	0.62
87.50	0.955	0.62
93.75	0.980	0.62
100.00	1.000	0.61
106.25	1.007	0.61
112.50	1.011	0.61
118.75	1.014	0.60
125.00	1.012	0.59

MB096 Horizontal

Airflow % Normal Capacity	Cooling Corrections	
	Sensible Capacity	Sens/Total Ratio
75.00	0.886	0.60
81.25	0.924	0.60
87.50	0.956	0.60
93.75	0.978	0.59
100.00	1.000	0.59
106.25	1.009	0.58
112.50	1.018	0.58
118.75	1.025	0.57
125.00	1.027	0.56

MB096 Vertical

Airflow % Normal Capacity	Cooling Corrections	
	Sensible Capacity	Sens/Total Ratio
75.00	0.911	0.62
81.25	0.947	0.61
87.50	0.968	0.61
93.75	0.982	0.61
100.00	1.000	0.61
106.25	1.013	0.60
112.50	1.013	0.59
118.75	1.007	0.59
125.00	1.002	0.58

MB120 Horizontal

Airflow % Normal Capacity	Cooling Corrections	
	Sensible Capacity	Sens/Total Ratio
75.00	0.923	0.59
81.25	0.955	0.58
87.50	0.978	0.58
93.75	0.990	0.57
100.00	1.000	0.56
106.25	0.994	0.54
112.50	0.985	0.53
118.75	0.973	0.51
125.00	0.953	0.49

MB120 Vertical

Airflow % Normal Capacity	Cooling Corrections	
	Sensible Capacity	Sens/Total Ratio
75.00	0.931	0.61
81.25	0.963	0.61
87.50	0.979	0.60
93.75	0.988	0.60
100.00	1.000	0.59
106.25	1.006	0.58
112.50	1.000	0.57
118.75	0.983	0.56
125.00	0.968	0.55

Waterside Economizer (WSE) Cooling Corrections

Models:
MB
072-300

MB168 Vertical

Airflow % Normal Capacity	Cooling Corrections	
	Sensible Capacity	Sens/Total Ratio
75.00	0.862	0.61
81.25	0.906	0.60
87.50	0.945	0.60
93.75	0.970	0.60
100.00	1.000	0.60
106.25	1.027	0.60
112.50	1.043	0.59
118.75	1.062	0.59
125.00	1.074	0.58

MB192 Vertical

Airflow % Normal Capacity	Cooling Corrections	
	Sensible Capacity	Sens/Total Ratio
75.00	0.872	0.60
81.25	0.914	0.60
87.50	0.951	0.60
93.75	0.972	0.60
100.00	1.000	0.59
106.25	1.024	0.59
112.50	1.036	0.58
118.75	1.049	0.58
125.00	1.057	0.57

MB240 Vertical

Airflow % Normal Capacity	Cooling Corrections	
	Sensible Capacity	Sens/Total Ratio
75.00	0.922	0.61
81.25	0.948	0.61
87.50	0.970	0.61
93.75	0.989	0.60
100.00	1.000	0.60
106.25	1.008	0.60
112.50	1.012	0.59
118.75	1.011	0.58
125.00	1.007	0.58

MB300 Vertical

Airflow % Normal Capacity	Cooling Corrections	
	Sensible Capacity	Sens/Total Ratio
75.00	0.924	0.61
81.25	0.949	0.61
87.50	0.970	0.60
93.75	0.987	0.60
100.00	1.000	0.60

Waterside Economizer (WSE) Airflow Ratings

Models:
MB
072-300

WSE Airflow Ratings tables include the following note:

- EAT 80/67; EWT 45; Nom Airflow @ 1.00" ESP; Nominal Water flow

MB072 Horizontal WSE 2,400 CFM Nominal Airflow

EWT °F	Waterside				Capacity	
	Flow GPM	LWT F°	WPD psi	WPD ft hd	TC	SC
45	18.0	48.8	3.8	8.7	29,804	17,778
	13.5	49.7	2.2	5.1	27,480	16,848
	9.0	51.2	1.0	2.4	23,905	15,462
50	18.0	53.0	3.8	8.7	23,034	15,122
	13.5	53.7	2.2	5.1	21,160	14,420
	9.0	55.0	1.0	2.4	18,342	13,740
55	18.0	57.5	3.8	8.7	18,409	16,619
	13.5	58.2	2.2	5.1	17,514	16,551
	9.0	59.4	1.0	2.4	15,881	14,978
60	18.0	62.0	3.8	8.7	14,082	13,245
	13.5	62.6	2.2	5.1	13,320	12,511
	9.0	63.6	1.0	2.4	12,023	11,262

MB072 Vertical WSE 2,400 CFM Nominal Airflow

EWT °F	Waterside				Capacity	
	Flow GPM	LWT F°	WPD psi	WPD ft hd	TC	SC
45	18.0	45.8	2.7	6.3	27,548	16,904
	13.5	45.7	1.5	3.6	24,818	15,840
	9.0	45.6	0.7	1.6	20,864	14,348
50	18.0	50.6	2.7	6.3	21,059	14,417
	13.5	50.6	1.5	3.6	18,896	13,623
	9.0	50.5	0.7	1.6	17,729	15,909
55	18.0	55.5	2.7	6.3	17,524	16,560
	13.5	55.5	1.5	3.6	16,409	15,486
	9.0	55.5	0.7	1.6	14,578	13,722
60	18.0	60.4	2.7	6.3	13,340	12,531
	13.5	60.4	1.5	3.6	12,458	11,681
	9.0	60.4	0.7	1.6	11,002	10,279

MB096 Horizontal WSE 3,200 CFM Nominal Airflow

EWT °F	Waterside				Capacity	
	Flow GPM	LWT F°	WPD psi	WPD ft hd	TC	SC
45	24.0	48.7	6.8	15.6	39,061	22,964
	18.0	49.6	3.9	9.1	36,298	21,841
	12.0	51.1	1.8	4.3	31,373	19,918
50	24.0	52.9	6.8	15.6	29,817	19,317
	18.0	53.7	3.9	9.1	27,810	18,570
	12.0	54.8	1.8	4.3	23,565	16,984
55	24.0	57.4	6.8	15.6	23,226	20,253
	18.0	58.1	3.9	9.1	22,639	21,201
	12.0	59.3	1.8	4.3	20,435	19,251
60	24.0	62.0	6.8	15.6	17,991	16,899
	18.0	62.5	3.9	9.1	17,018	15,960
	12.0	63.5	1.8	4.3	15,005	14,007

MB096 Vertical WSE 3,200 CFM Nominal Airflow

EWT °F	Waterside				Capacity	
	Flow GPM	LWT F°	WPD psi	WPD ft hd	TC	SC
45	24.0	48.4	4.8	11.0	35,545	21,568
	18.0	49.2	2.7	6.3	32,522	20,374
	12.0	50.4	1.2	2.8	27,179	18,352
50	24.0	52.7	4.8	11.0	27,278	18,386
	18.0	53.3	2.7	6.3	24,401	17,335
	12.0	54.7	1.2	2.8	22,516	19,694
55	24.0	57.3	4.8	11.0	22,333	21,079
	18.0	57.9	2.7	6.3	20,942	19,739
	12.0	59.0	1.2	2.8	18,632	17,513
60	24.0	61.9	4.8	11.0	16,959	15,905
	18.0	62.4	2.7	6.3	15,822	14,809
	12.0	63.2	1.2	2.8	13,592	12,646

Waterside Economizer (WSE) Airflow Ratings

Models:
MB
072-300

MB120 Horizontal WSE 4,000 CFM Nominal Airflow

EWT °F	Waterside				Capacity	
	Flow GPM	LWT F°	WPD psi	WPD ft hd	TC	SC
45	30.0	48.6	6.2	14.3	43,659	24,291
	22.5	49.5	3.6	8.4	40,385	22,968
	15.0	50.9	1.7	3.9	34,534	20,675
50	30.0	52.8	6.2	14.3	32,557	19,909
	22.5	53.6	3.6	8.4	30,180	19,015
	15.0	54.7	1.7	3.9	25,209	17,186
55	30.0	57.3	6.2	14.3	24,557	20,818
	22.5	58.0	3.6	8.4	23,763	22,035
	15.0	59.1	1.7	3.9	21,198	19,770
60	30.0	61.9	6.2	14.3	18,147	16,832
	22.5	62.4	3.6	8.4	17,052	15,777
	15.0	63.3	1.7	3.9	15,172	13,967

MB120 Vertical WSE 4,000 CFM Nominal Airflow

EWT °F	Waterside				Capacity	
	Flow GPM	LWT F°	WPD psi	WPD ft hd	TC	SC
45	30.0	48.3	3.0	7.0	41,300	24,495
	22.5	49.1	1.7	4.0	37,714	23,077
	15.0	50.2	0.8	1.8	31,379	20,676
50	30.0	52.6	3.0	7.0	31,336	20,620
	22.5	53.2	1.7	4.0	27,886	19,342
	15.0	54.5	0.8	1.8	25,461	21,740
55	30.0	57.2	3.0	7.0	25,187	23,678
	22.5	57.8	1.7	4.0	23,536	22,088
	15.0	58.8	0.8	1.8	20,844	19,496
60	30.0	61.8	3.0	7.0	18,719	17,449
	22.5	62.3	1.7	4.0	17,434	16,212
	15.0	63.1	0.8	1.8	15,289	14,146

MB168 Vertical WSE 5,600 CFM Nominal Airflow

EWT °F	Waterside				Capacity	
	Flow GPM	LWT F°	WPD psi	WPD ft hd	TC	SC
45	42.0	49.0	4.8	11.0	76,156	45,598
	31.5	50.0	2.8	6.5	70,874	43,453
	21.0	51.6	1.3	3.1	62,602	40,179
50	42.0	53.2	4.8	11.0	59,555	38,958
	31.5	53.9	2.8	6.5	54,953	37,209
	21.0	55.3	1.3	3.1	48,162	34,699
55	42.0	57.5	4.8	11.0	45,757	38,463
	31.5	58.4	2.8	6.5	46,368	42,567
	21.0	59.6	1.3	3.1	41,469	39,275
60	42.0	62.1	4.8	11.0	36,407	34,399
	31.5	62.7	2.8	6.5	34,760	32,812
	21.0	63.7	1.3	3.1	32,009	30,166

MB192 Vertical WSE 6,400 CFM Nominal Airflow

EWT °F	Waterside				Capacity	
	Flow GPM	LWT F°	WPD psi	WPD ft hd	TC	SC
45	48.0	48.9	5.9	13.5	83,715	49,510
	36.0	49.9	3.5	8.1	77,852	47,129
	24.0	51.5	1.7	3.9	68,677	43,501
50	48.0	53.1	5.9	13.5	65,234	42,158
	36.0	53.9	3.5	8.1	60,117	40,210
	24.0	55.2	1.7	3.9	52,582	37,428
55	48.0	57.5	5.9	13.5	49,679	41,469
	36.0	58.3	3.5	8.1	50,341	46,088
	24.0	59.5	1.7	3.9	44,942	42,483
60	48.0	62.0	5.9	13.5	39,250	37,001
	36.0	62.6	3.5	8.1	37,445	35,262
	24.0	63.6	1.7	3.9	34,280	32,213

MB240 Vertical WSE 8,000 CFM Nominal Airflow

EWT °F	Waterside				Capacity	
	Flow GPM	LWT F°	WPD psi	WPD ft hd	TC	SC
45	60.0	51.0	15.0	34.6	165,124	99,273
	45.0	52.5	9.0	20.9	151,928	93,931
	30.0	54.9	4.5	10.3	132,467	86,302
50	60.0	54.8	15.0	34.6	128,187	84,527
	45.0	55.9	9.0	20.9	116,892	80,250
	30.0	57.8	4.5	10.3	100,663	75,438
55	60.0	58.9	15.0	34.6	100,606	86,703
	45.0	60.1	9.0	20.9	99,532	88,502
	30.0	62.0	4.5	10.3	87,994	81,279
60	60.0	63.1	15.0	34.6	76,126	72,152
	45.0	63.9	9.0	20.9	72,497	68,656
	30.0	65.5	4.5	10.3	66,067	62,462

MB300 Vertical WSE 10,000 CFM Nominal Airflow

EWT °F	Waterside				Capacity	
	Flow GPM	LWT F°	WPD psi	WPD ft hd	TC	SC
45	75.0	50.6	18.3	42.2	189,286	112,711
	56.3	51.9	10.6	24.5	175,596	107,150
	37.5	54.3	4.8	11.1	154,285	98,745
50	75.0	54.4	18.3	42.2	147,281	96,007
	56.3	55.5	10.6	24.5	134,899	91,299
	37.5	57.2	4.8	11.1	116,174	84,855
55	75.0	58.6	18.3	42.2	115,518	98,176
	56.3	59.9	10.6	24.5	118,368	105,192
	37.5	61.6	4.8	11.1	104,828	96,837
60	75.0	62.9	18.3	42.2	90,334	85,588
	56.3	63.7	10.6	24.5	86,190	81,597
	37.5	65.2	4.8	11.1	78,786	74,464

Dimensional Data MB072-120 Horizontal

Models:
MB
072-300

Unit Size	Overall Cabinet			Discharge Connections Duct Flange				Water Connections			Electrical Knockouts						Return Air Connections Using Return Air Opening								
	A	B	C	D	E	F	G	K	L	M	O				Q		S		T	U	V				
	Width	Depth	Height	Side Offset	Supply Width	Supply Height	Supply Offset	Water Outlet	Water Inlet	1	2	P				7/8"		Return Depth		Return Height	Unit Top Height	072	096-120		
												1	2	3	4	1	2	072	096-120						
072-120	inch	36.3	84.9	21.6	13.9	17.1	13.5	7.4	15.0	18.0	3.5	3.0	2.7	19.4	14.3	7.3	2.1	16.8	4.8	55.0	65.0	18.0	1.0	28.9	18.9
	cm	92.2	215.6	54.9	35.2	43.4	34.3	19.8	38.1	45.7	8.9	7.6	6.8	49.2	36.3	18.6	5.4	42.7	12.2	139.7	165.1	45.7	2.5	73.4	48.0

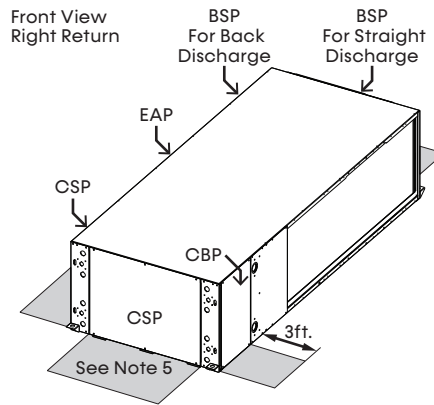
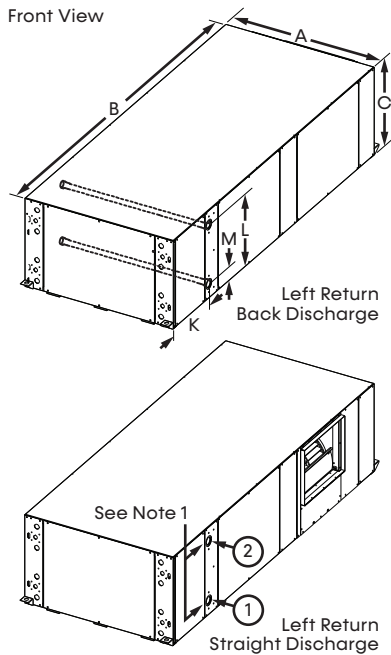

NOTES

- Water inlet and water outlet connections are field configurable on either side (left or right) of the unit.
- Condensate drain is 3/4-inch FPT and is located on cabinet end opposite the compressor.
- Electrical access is configurable on either side (left or right) of the front.
- If the control box is configured on one side, it can be field converted to the opposite side. Conversion should only be attempted by a qualified service technician.
- Units require 3 feet (90.1 cm) of clearance for water connections, CSP, CBP, EAP, and BSP service access. Service access is required at all removable panels locations and the installer should take care to comply with all building codes and allow adequate clearance for future field service.
- Overall cabinet width dimensions do not include filter rail and duct flange.
- Units are shipped with air filter rails that are not suitable for supporting return air ductwork. An air filter frame with duct mounting collar is available to order as an accessory.

LEGEND

- BSP** = Blower Service Panel
CSP = Compressor Service Panel
CBP = Control Box Panel
EAP = Expansion Valve Access Panel

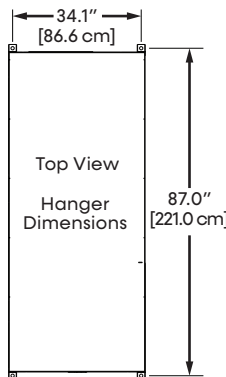
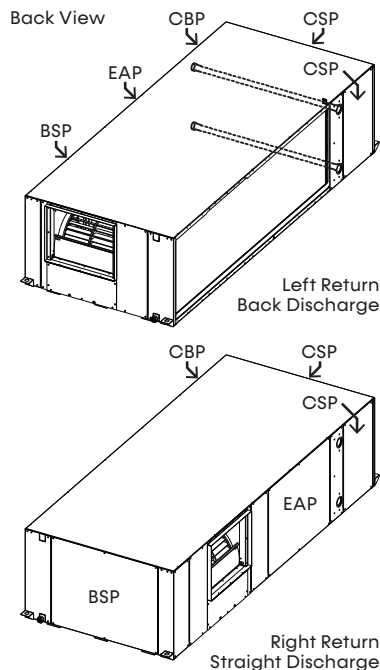

Notes	MB072-096	MB120
① Water Inlet ¹	1-1/4" FPT	1-1/2" FPT
② Water Outlet ¹	1-1/4" FPT	1-1/2" FPT
③ Condensate Drain ²	1" FPT	
④ High Voltage Access ³	1-3/8" (3.49 cm)	
⑤ Low Voltage Access ³	7/8" (2.2 cm)	

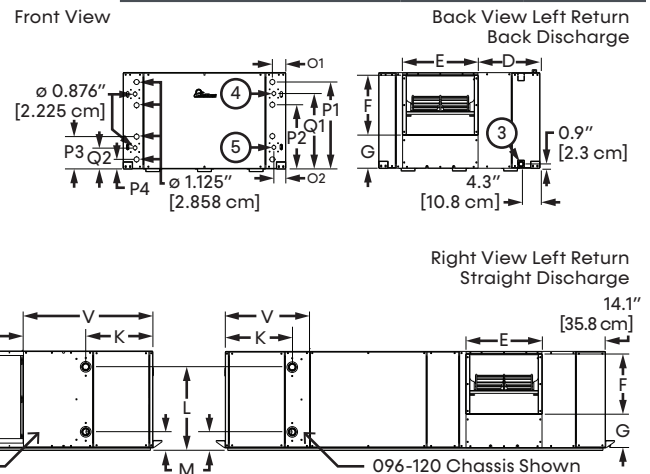

Dimensional Data MB072-120 Horizontal with WSE

Models:
MB
072-300

Unit Size	Overall Cabinet			Discharge Connections Duct Flange				Water Connections			Electrical Knockouts						Return Air Connections Using Return Air Opening								
	A	B	C	D	E	F	G	K	L	M	O				Q		S		T	U	V				
	Width	Depth	Height	Side Offset	Supply Width	Supply Height	Supply Offset		1	2	1	2	1	2	3	4	1	2	Return Depth		Return Height	Unit Top Height			
									Water Outlet	Water Inlet	1-1/8" (2.9 cm)	7/8" (2.2 cm)	1-1/8" (2.9 cm)				7/8" (2.2 cm)		072	096-120					
072-120	inch	46.3	84.9	21.6	23.9	17.1	13.5	7.4	15.0	18.0	3.5	3.0	2.7	19.4	14.3	7.2	2.1	16.8	4.7	55.1	61.0	18.5	1.0	28.9	22.8
	cm	117.6	215.6	54.8	60.6	43.4	34.3	18.8	38.1	45.7	8.9	7.6	6.8	49.2	36.3	18.3	5.4	42.7	11.9	140.0	154.9	47.0	2.5	73.4	57.9

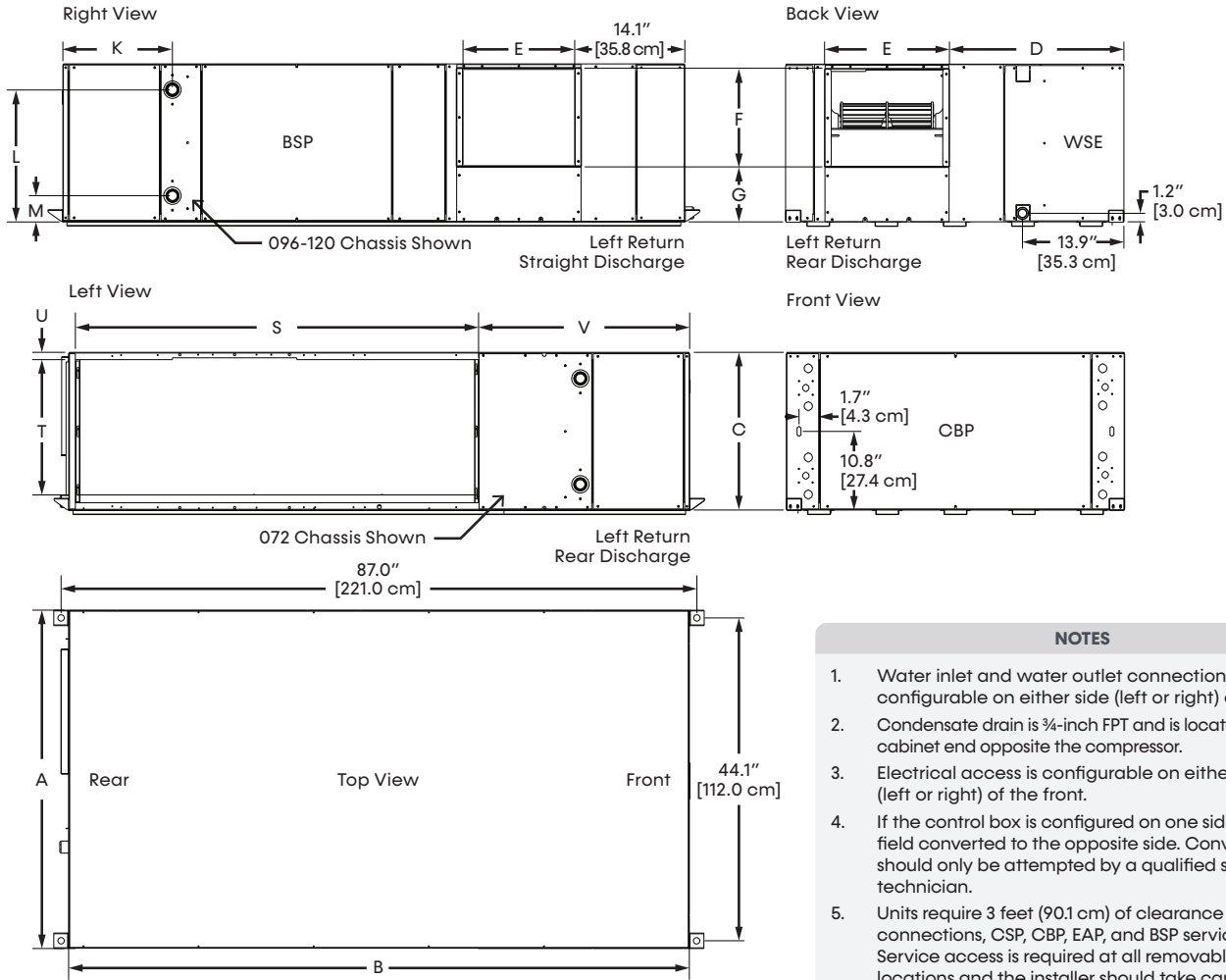

LEGEND	
BSP	= Blower Service Panel
CSP	= Compressor Service Panel
CBP	= Control Box Panel
EAP	= Expansion Valve Access Panel
WSE	= Waterside Economizer

- NOTES**
- Water inlet and water outlet connections are configurable on either side (left or right) of the unit.
 - Condensate drain is 3/4-inch FPT and is located on cabinet end opposite the compressor.
 - Electrical access is configurable on either side (left or right) of the front.
 - If the control box is configured on one side, it can be field converted to the opposite side. Conversion should only be attempted by a qualified service technician.
 - Units require 3 feet (90.1 cm) of clearance for water connections, CSP, CBP, EAP, and BSP service access. Service access is required at all removable panels locations and the installer should take care to comply with all building codes and allow adequate clearance for future field service.
 - Overall cabinet width dimensions do not include filter rail and duct flange.
 - Units are shipped with air-filter rails that are not suitable for supporting return air ductwork. An air filter frame with duct mounting collar is available to order as an accessory.

Dimensional Data MB072-120 Vertical

Models:
MB
072-300

Unit Size		Overall Cabinet			Discharge Connections Duct Flange			Water Connections				Electrical Knockouts			Return Air Connections Using Return Air Opening					
		A	B	C	D	E	F	K	L	M	N	O			P	Q	S	T	U	V
		Width	Depth	Height	Supply Width	Supply Height	Side Offset	1	2	3	Connection Height	1	2	3	7/8" (2.2 cm)	Return Width	Return Height			
072	inch	41.0	29.0	69.8	17.5	14.8	11.9	22.0	7.2	14.6	22.3	3.0	11.0	19.0						
	cm	104.1	73.3	177.3	44.5	37.6	30.2	55.9	18.3	37.1	56.6	7.6	27.9	48.3	38.1	2.3	92.2	74.7	72.6	11.4
096-120	inch	41.0	29.0	69.8	17.5	14.8	11.9	22.0	7.2	14.6	22.3	3.0	11.0	19.0	15.0	0.9	36.0	35.1	28.6	2.6
	cm	104.1	73.3	177.3	44.5	37.6	30.2	55.9	18.3	37.1	56.6	7.6	27.9	48.3	38.1	2.3	91.4	89.2	72.6	6.6

NOTES

- Condensate drain is available on either side (left or right) of unit. Drain hose and drain connection will be tied inside the unit. Installer will untie the drain hose, form trap, and connect to the condensate drain hole of installer's choice.
- Electrical access is available on either side (left or right) of unit and is also available in the front on the left or right side of the unit.
- Overall cabinet dimensions do not include duct flange or filter rails.
- Units require 3 feet (90.1 cm) of clearance for water connections, CSP, CBP, MSP, and BSP service access. Service access is required at all removable panels locations and installer should take care to comply with all building codes and allow adequate clearance for future field service.
- Filter removal is from right or left side of filter frame, allow 3 feet (61 cm) of access for servicing.

Front View
Top Discharge

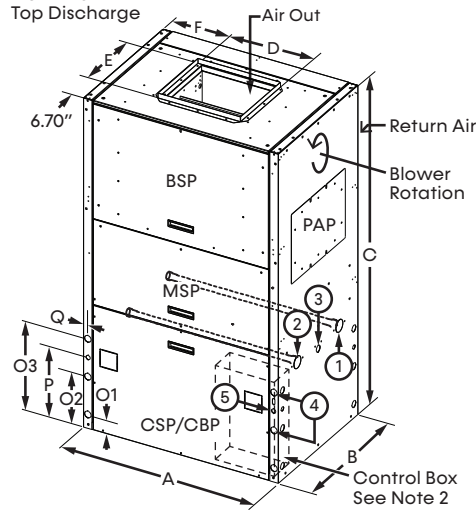

Rear View
Top Discharge

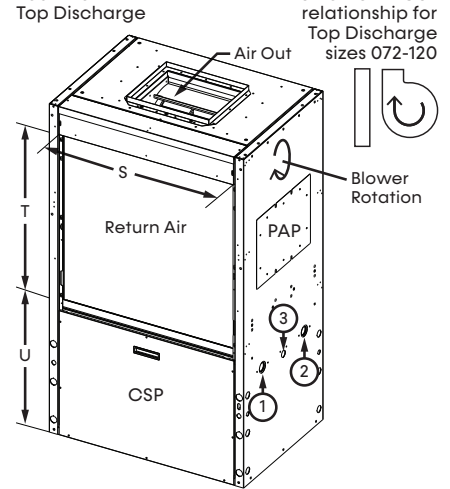

Front View
Straight Discharge

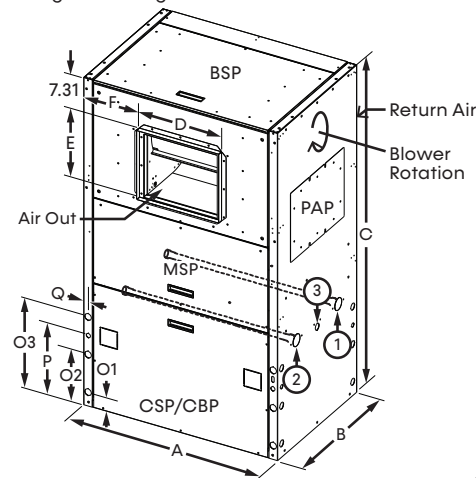

Rear View
Straight Discharge

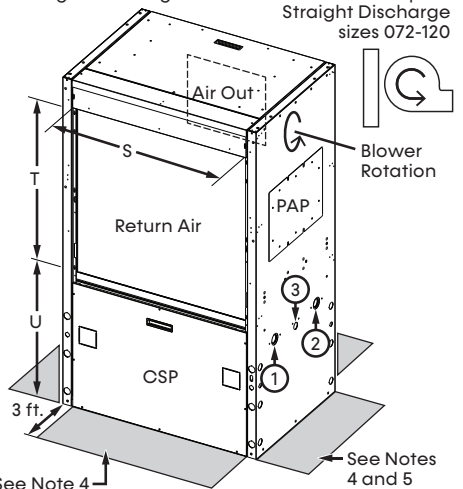

Right Side View
Straight Discharge

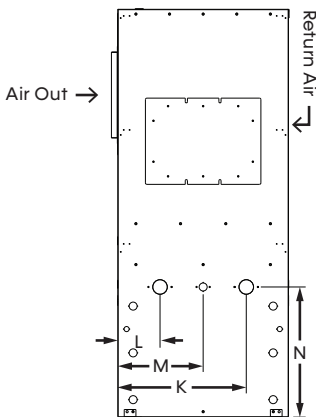

Notes	MB072-096	MB120
① Water Inlet ¹	1-1/4" FPT	1-1/2" FPT
② Water Outlet ¹	1-1/4" FPT	1-1/2" FPT
③ Condensate Drain ²	1" FPT	
④ High Voltage Access ³	1-3/8" (3.49 cm)	
⑤ Low Voltage Access ³	7/8" (2.2 cm)	

LEGEND

BSP = Blower Service Panel
CBP = Control Box Panel
CSP = Compressor Service Panel
MSP = Motor Service Panel
PAP = Pulley Access Panel

Dimensional Data MB072-120 Vertical with WSE

Models:
MB
072-300

Unit Size		Overall Cabinet			Discharge Connections Duct Flange			Water Connections				Electrical Knockouts			Return Air Connections Using Return Air Opening					
		A	B	C	D	E	F	K	L	M	N	O			P	Q	S	T	U	V
		Width	Depth	Height	Supply Width	Supply Height	Side Offset	1	2	3	Connection Height	1	2	3			Return Width	Return Height		Return Side Offset
072	inch	41.3	39.2	69.8	17.5	14.7	11.9	22.0	7.2	14.6		22.3	3.0	11.0	19.0	15.1				
	cm	104.9	99.6	177.3	44.5	37.3	30.2	55.9	18.3	37.1	56.6	7.6	27.9	48.3	38.4	2.3	86.4	80.3	72.7	9.1
096-120	inch	41.3	39.2	69.8	17.5	14.7	11.9	22.3	6.9	14.6	22.3	3.0	11.0	19.0	15.1	0.9	36.0	34.1	28.6	3.0
	cm	104.9	99.6	177.3	44.5	37.3	30.2	56.6	17.5	37.1	56.6	7.6	27.9	48.3	38.4	2.3	91.4	86.6	72.7	7.5

Top View
Rear Return Front Discharge

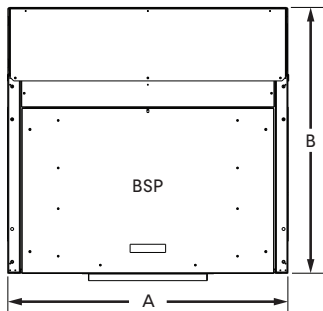

Top View
Rear Return Top Discharge

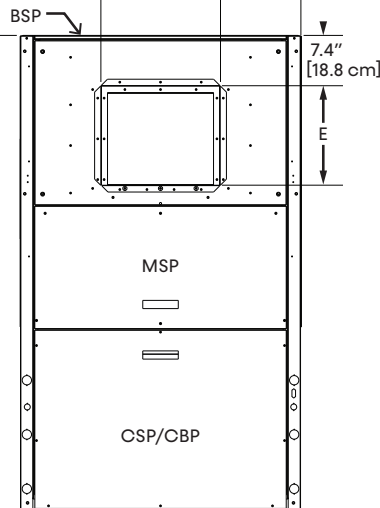
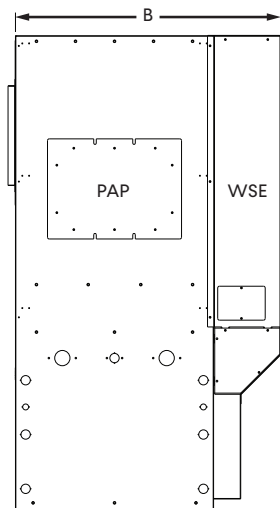
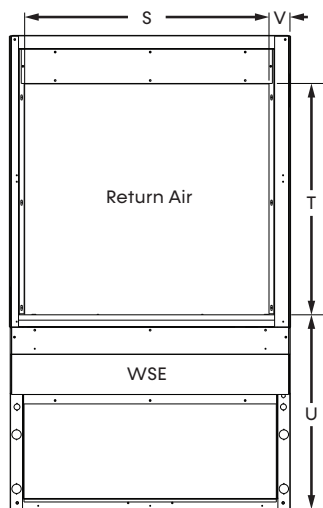
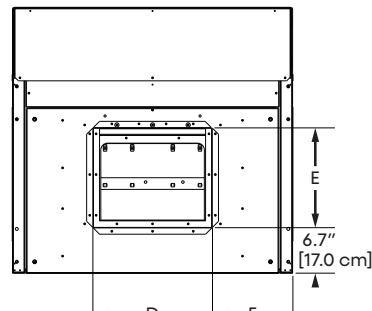

Back View
Rear Return Front Discharge

Right Side View

Front View
Rear Return Front Discharge

NOTES

- See the standard configuration for water connection and electrical knockout dimensions.
- While clear access to all removable panels may not be required, installer should take care to comply with all building codes and allow adequate clearance for future field service.
 - Units require 3 feet (91 cm) of clearance for water connections, WSE coil air bleed, CBP, CSP, BSP, PAP, and MSP.
 - Condensate drain is internally trapped, externally vented.
 - For top discharge units, BSP is on front. For front discharge units, BSP is on top. Allow 3 feet above unit for service.

LEGEND

- BSP = Blower Service Panel
- CSP = Compressor Service Panel
- CBP = Control Box Panel
- MSP = Motor Service Panel
- PAP = Pulley Access Panel
- WSE = Waterside Economizer

Dimensional Data MB168-240 Vertical

Models:
MB
072-300

Unit Size		Overall Cabinet			Discharge Connections Duct Flange			Water Connections				Electrical Knockouts			Return Air Connections Using Return Air Opening						
		A	B	C	D	E	F	K	L	M	N	O			P	Q	S	T	U	V	
		Width	Depth	Height	Supply Width	Supply Height	Side Offset	1	2	3	Connection Height	1	2	3	7/8" (2.2 cm)	Return Width	Return Height				
								Water In	Water Out	Condensate		1-3/8" (3.5cm)									
168-240	inch	82.3	29.2	69.8	46.5	14.7	17.9	26.2	3.1	14.6	25.8	3.0	11.0	19.0	13.0	0.9	77.2	35.0	31.0	2.6	
	cm	209.0	74.2	177.3	118.1	37.3	45.5	66.5	7.9	37.1	65.5	7.6	27.9	48.3	33.0	2.3	196.1	88.9	78.7	6.6	

Front View
Top Discharge

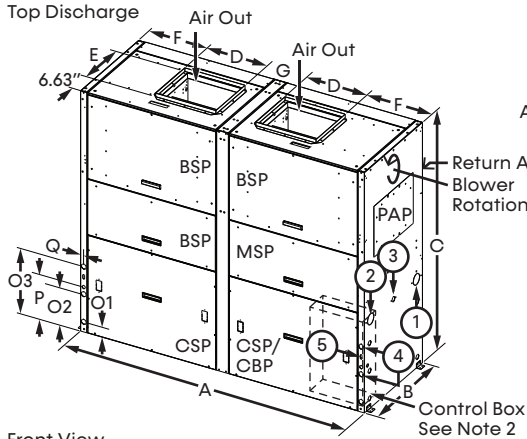

Front Return Rear Discharge (FR/RD)

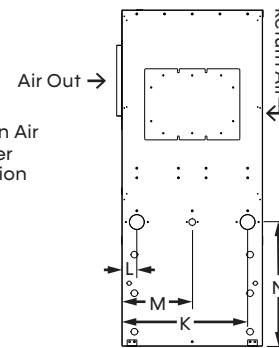

Rear View
Top Discharge

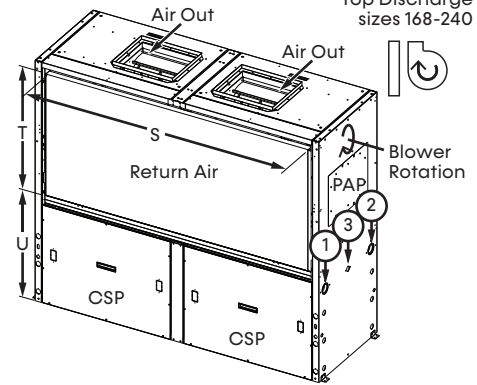

Blower to Air Coil
relationship for
Top Discharge
sizes 168-240

Front View
Straight Discharge

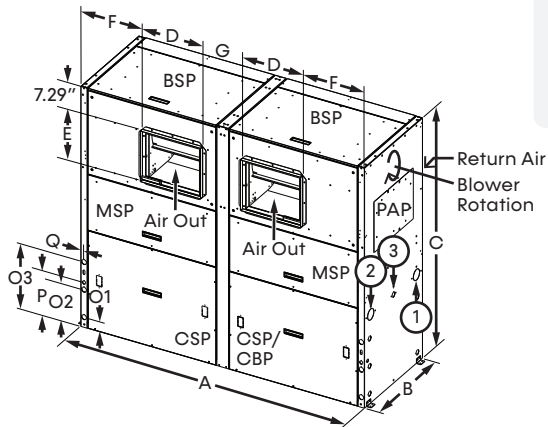

LEGEND

- BSP = Blower Service Panel
- CBP = Control Box Panel
- CSP = Compressor Service Panel
- MSP = Motor Service Panel
- PAP = Pulley Access Panel

Rear View
Straight Discharge

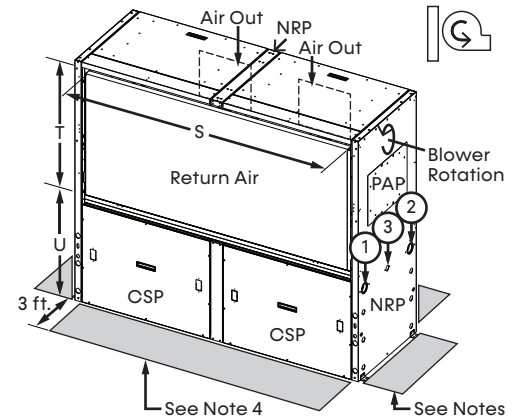

Blower to Air Coil
relationship for
Straight Discharge
sizes 168-240

NOTES

- Condensate drain is available on either side (left or right) of unit. Drain hose and drain connection will be tied inside the unit. The installer will untie the drain hose, form trap, and connect to the condensate drain hole of installer's choice.
- Electrical access is available on either side (left or right) of unit and is also available in the front on the left or right side of the unit.
- Overall cabinet height and depth dimensions do not include duct flange or filter rails.
- Units require 3 feet (91 cm) of clearance for water connections, CBP, CSP, MSP, and BSP service access. Service access is required at all removable panels locations and installer should take care to comply with all building codes and allow adequate clearance for future field service.
- Filter removal is from right or left side of filter frame, allow 3 feet (91 cm) of access for servicing.

Legend	MB168-240
① Water Inlet	2" FPT
② Water Outlet	2" FPT
③ Condensate Drain ¹	1" FPT
④ High Voltage Access ²	1-3/8" (3.49 cm)
⑤ Low Voltage Access ²	7/8" (2.2 cm)

Dimensional Data MB168-240 Vertical with WSE

Models:
MB
072-300

Unit Size		Overall Cabinet			Discharge Connections Duct Flange			Water Connections				Electrical Knockouts			Return Air Connections Using Return Air Opening					
		A	B	C	D	E	F	K	L	M	N	O			P	Q	S	T	U	V
		Width	Depth	Height	Supply Width	Supply Height	Side Offset	1	2	3	Connection Height	1	2	3			Return Width	Return Height		Return Side Offset
168-240	inch	82.3	42.0	69.8	46.5	14.7	17.9	26.1	3.1	14.6	25.8	3.0	11.0	19.0	15.1	0.9	76.0	34.0	30.7	3.6
	cm	209.0	106.7	177.3	118.1	37.3	45.5	66.3	7.9	37.1	65.5	7.6	27.9	48.3	38.4	2.3	193.0	86.4	78.0	9.1

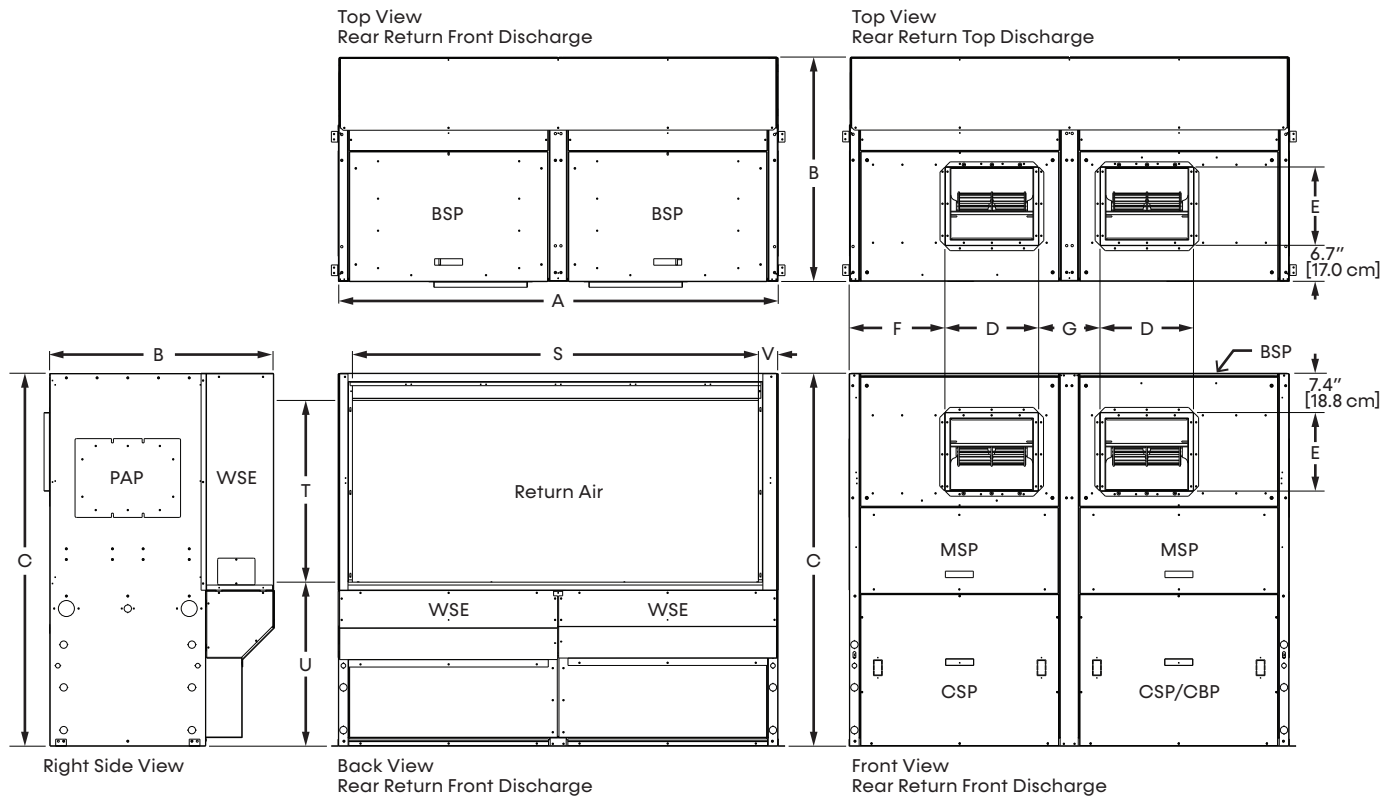

NOTES

See the standard configuration for water connection and electrical knockout dimensions.

- While clear access to all removable panels may not be required, the installer should take care to comply with all building codes and allow adequate clearance for future field service.
- Units require 3 feet (91 cm) of clearance for water connections, WSE coil air bleed, CBP, CSP, BSP, PAP, and MSP.
- Condensate drain is internally trapped, externally vented.
- For top discharge units, BSP is on front. For front discharge units, BSP is on top. Allow 3 feet above unit for service.

LEGEND

- BSP** = Blower Service Panel
- CSP** = Compressor Service Panel
- CBP** = Control Box Panel
- MSP** = Motor Service Panel
- PAP** = Pulley Access Panel
- WSE** = Waterside Economizer

Dimensional Data MB300 Vertical

Models:
MB
072-300

Unit Size	Overall Cabinet			Discharge Connections Duct Flange			Water Connections				Electrical Knockouts			Return Air Connections Using Return Air Opening						
	A	B	C	D	E	F	K	L	M	N	O			P	Q	S	T	U	V	
	Width	Depth	Height	Supply Width	Supply Height	Side Offset	1	2	3	Connection Height	1	2	3	7/8" (2.2 cm)		Return Width	Return Height			
											1-3/8" (3.5 cm)									
300	inch	82.3	29.2	69.8	46.5	14.7	17.9	25.8	3.4	14.6	24.2	3.0	11.0	19.0	13.0	0.9	77.2	35.0	31.0	2.6
	cm	209.0	74.2	177.3	118.1	37.3	45.5	65.5	8.6	37.1	61.5	7.6	27.7	48.3	33.0	2.3	196.1	88.9	78.7	6.6

Front View
Top Discharge

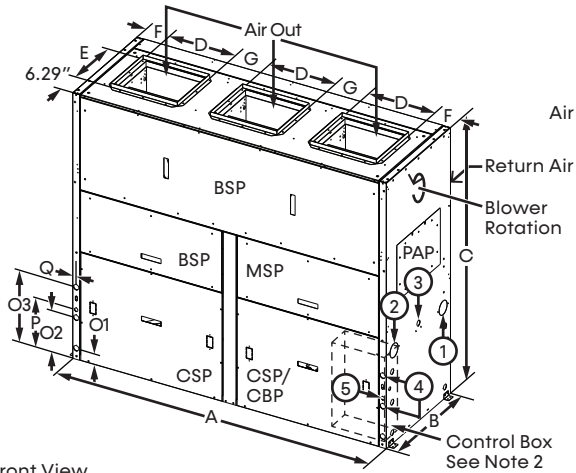

Right Side View
Straight Discharge

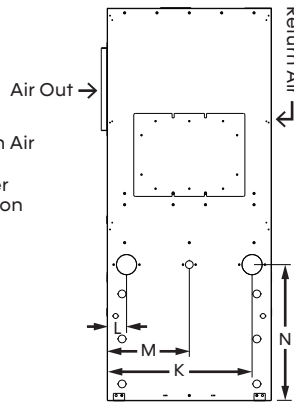

Rear Return
Top Discharge

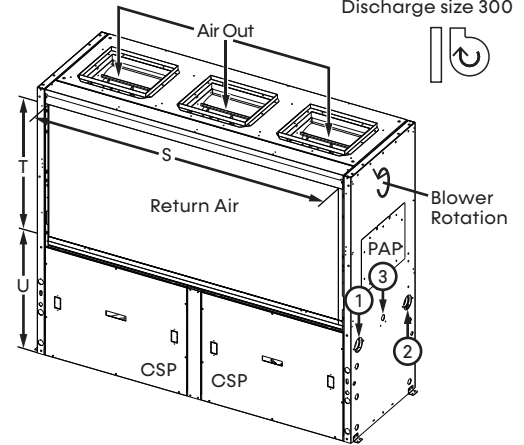

Blower to Air Coil
relationship for Top
Discharge size 300

Front View
Straight Discharge

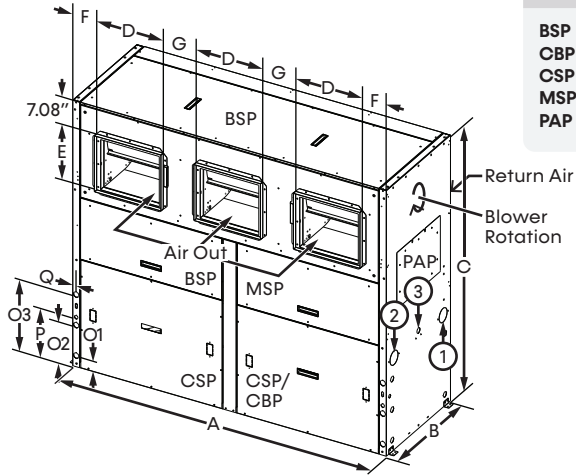

LEGEND

BSP = Blower Service Panel
CBP = Control Box Panel
CSP = Compressor Service Panel
MSP = Motor Service Panel
PAP = Pulley Access Panel

Rear View
Straight Discharge

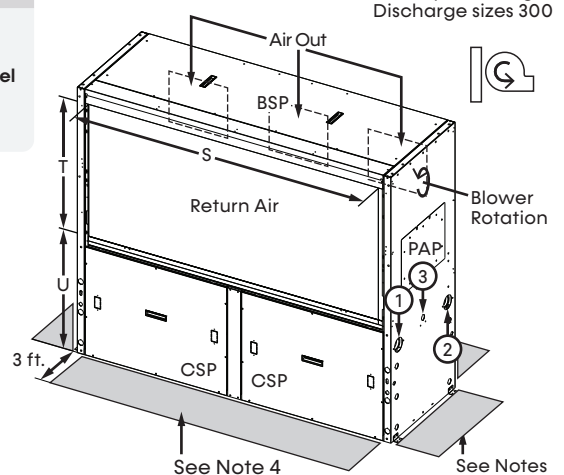

Blower to Air Coil
relationship for Straight
Discharge sizes 300

NOTES

- Condensate drain is available on either side (left or right) of unit. Drain hose and drain connection are tied inside the unit. The installer will untie the drain hose, form trap, and connect to the condensate drain hole of installer's choice.
- Electrical access is available on either side (left or right) of unit and is also available in the front on the left or right side of the unit.
- Overall cabinet height and depth dimension does not include duct flange for or filter rails.
- Units require 3 feet (91 cm) of clearance, CBP, CSP, MSP and BSP service access. While access to all removable panels may not be required, the installer should take care to comply with all building codes and allow adequate clearance for future field service.
- Filter removal is from right or left side of filter frame, allow 3 feet (91 cm) of access for servicing.

Legend	MB300
① Water Inlet	2-1/2" FPT
② Water Outlet	2-1/2" FPT
③ Condensate Drain ¹	1" FPT
④ High Voltage Access ²	1-3/8" (3.49 cm)
⑥ Low Voltage Access ²	7/8" (2.2 cm)

Dimensional Data MB300 Vertical with WSE

Models:
MB
072-300

Unit Size		Overall Cabinet			Discharge Connections Duct Flange			Water Connections				Electrical Knockouts			Return Air Connections Using Return Air Opening					
		A	B	C	D	E	F	K	L	M	N	O			P	Q	S	T	U	V
		Width	Depth	Height	Supply Width	Supply Height	Side Offset	1	2	3	Connection Height	1	2	3			Return Width	Return Height		Return Side Offset
								Water In	Water Out	Condensate										
300	inch	82.3	42.0	69.8	46.5	14.7	17.9	25.8	3.4	14.6	24.2	3.0	11.0	19.0	15.1	0.9	76.0	34.0	30.7	3.6
	cm	209.0	106.7	177.3	118.1	37.3	45.5	65.5	8.6	37.1	61.5	7.6	27.9	48.3	38.4	2.3	193.0	86.4	78.0	9.1

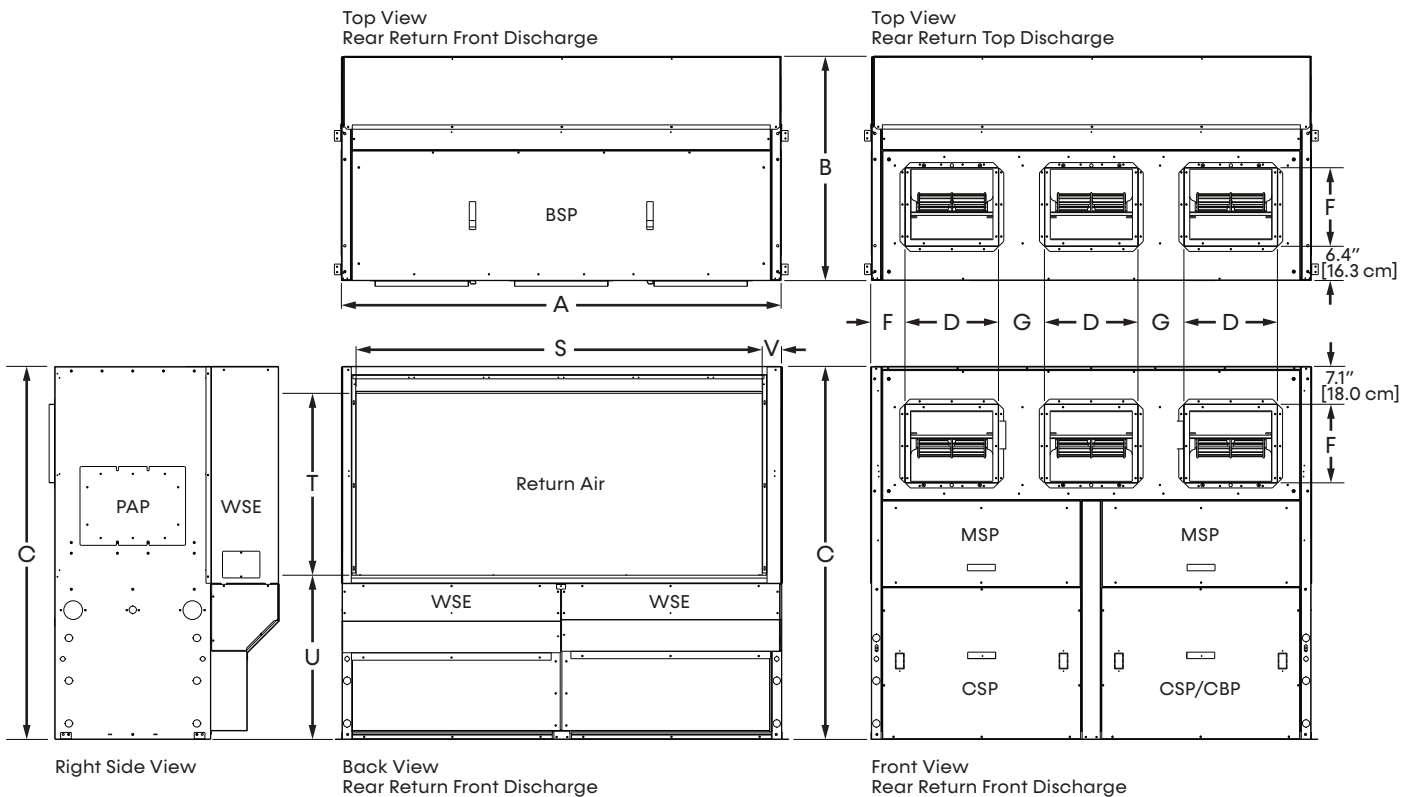

NOTES

See the standard configuration for water connection and electrical knockout dimensions.

1. While clear access to all removable panels may not be required, installer should take care to comply with all building codes and allow adequate clearance for future field service.
2. Units require 3 feet (91 cm) of clearance for water connections, WSE coil air bleed, CBP, CSP, BSP, PAP, and MSP.
3. Condensate drain is internally trapped, externally vented.
4. For top discharge units, BSP is on front. For front discharge units, BSP is on top. Allow 3 feet above unit for service.

LEGEND

BSP = Blower Service Panel
CSP = Compressor Service Panel
CBP = Control Box Panel
MSP = Motor Service Panel
PAP = Pulley Access Panel
WSE = Waterside Economizer

MINIMUM INSTALLATION AREA

Minimum area where a blower-equipped unit must be installed, and mechanical/natural ventilation is not required

Model	Charge (oz)	Configuration	Minimum Installation Area ft ² (m ²) [A _{min}]			
			Floor	Window	Wall	Ceiling
MB072	54	Vertical	186	70	46	40
		Horizontal	186	70	46	40
MB096	62	Vertical	213	80	53	46
		Horizontal	213	80	53	46
MB120	66	Vertical	227	85	57	49
		Horizontal	213	80	53	46
MB168	94	Vertical	323	121	81	69
MB192	103	Vertical	354	133	89	76
MB240	134	Vertical	461	173	115	99
MB300	184	Vertical	633	237	158	136

A _{min}	=	Minimum area where unit is installed where unit has incorporated airflow
h _{inst} (floor)	=	0.0 ft (0.0 m)
h _{inst} (window)	=	3.3 ft (1.0 m)
h _{inst} (wall)	=	5.9 ft (1.8 m)
h _{inst} (ceiling)	=	7.2 ft (2.2 m)

Minimum area and CFM requirements for the conditioned space

Model	Charge (oz)	Minimum CFM [Q _{min}]	
		TA _{min} (ft ²)	Q _{min} (ft ³ /min)
MB072	54	2.77	91
MB096	62	3.18	105
MB120	66	3.38	112
MB168	94	4.82	159
MB192	103	5.28	174
MB240	134	6.87	227
MB300	184	9.43	311

TA _{min}	=	Minimum conditioned area for venting leaked refrigerant
Q _{min}	=	Minimum ventilation flow rate for conditioned space if space is less than TA _{min}

Minimum area of opening for natural ventilation

Model	Charge (oz)	A _{nv} (in ²)
MB072	54	98.70
MB096	62	105.76
MB120	66	109.12
MB168	94	130.22
MB192	103	136.31
MB240	134	155.48
MB300	184	182.19

A _{nv}	=	Minimum natural ventilation area opening
-----------------	---	------------------------------------------

When the openings for connected rooms or natural ventilation are required, apply the following conditions:

- The area of any openings above 11.8 inches (300 mm) from the floor shall not be considered in determining compliance with Anv_{min}.
- At least 50% of the required opening area Anv_{min} shall be below 7.8 inches (200 mm) from the floor.
- The bottom of the lowest openings shall not be higher than the point of release when the unit is installed and not more than 3.9 inches (100 mm) from the floor.
- Openings are permanent openings which cannot be closed.
- For openings extending to the floor, the height shall not be less than 0.78 inch (20 mm) above the surface of the floor covering.
- A second higher opening shall be provided. The total size of the second opening shall not be less than 50% of minimum opening area for Anv_{min} and shall be at least 3.3 ft (1.5 m) above the floor.

Blower Motor Variable Frequency Drive (VFD) Controls (Optional)

Models:
MB
072-300

VFD BLOWER

Variable Frequency Drives are controllers that vary electrical frequency and voltage to the fan motor. Electrical frequency is directly related to a fan motor's speed (RPM's). The faster the frequency, the faster the motor will go and vice versa. VFD's allow the fan motor to ramp speed (CFM) up or down to match the load of the space they are satisfying. This allows the MC to deliver variable capacity, optimizing system efficiency and saving owners money.

VFD controllers come factory installed and tested to provide supply fan motor speed modulation. VFDs on the supply fan, are quieter, more efficient, and are eligible for utility rebates. These products are commonly used in single-zone, variable-air-volume (VAV) applications. When applied to single-zone VAV applications the system modulates the indoor fan and stages compressors as space temperature changes, for increased part-load efficiency and more precise temperature control with fan speed varying down to 37.5% of maximum air flow. The VFD controls are paired with our intelligent CXM2 Communicating Controls to provide superior service and functionality.

VFD BLOWER SEQUENCE OF OPERATION

The VFD blower option comes factory programmed with the standard CXM2. The CXM2 controls the VFD blower controller using a 0–10VDC control signal, and comes factory programmed for Leaving Air Temperature (LAT) control mode. The actual operating range for the VFD when the blower should be active will be 3.7–10.0VDC associated to the operating speeds of 37–100%. When the VFD is off, the output should be set to 0VDC. For each unit size, there is a maximum and minimum operating speed at which the VFD can operate at for any mode, defined in the **VFD Control Valves** table.

The VFD blower may be operated in LAT or discrete-speed control modes.

NOTE: At the end of a heating or cooling demand cycle, the VFD is set to 50% of the final demand value during the blower-off delay time.

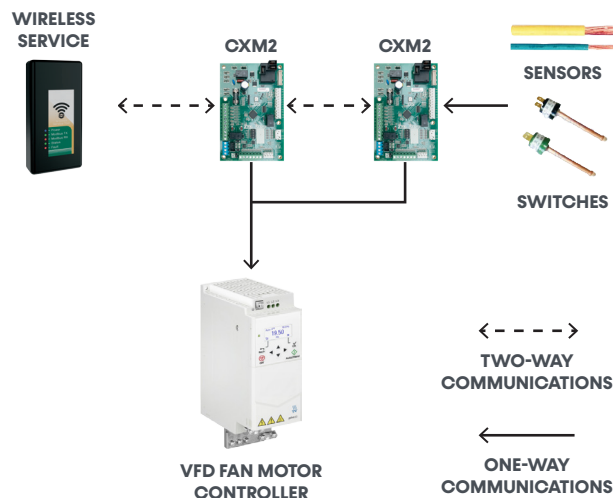

Blower Motor Variable Frequency Drive (VFD) Controls (Optional)

Models:
MB
072-300

LAT CONTROL VFD OPERATION

The CXM2 comes factory configured for LAT control operation. The VFD speed is controlled by the CXM2 to maintain the factory default LAT set point, 55°F for cooling and 105°F for heating. LAT can be adjusted in the field. See the **VFD Control Valves** table for full details.

When a compressor demand is recognized, the VFD output is set to the most recent demand operating speed of the VFD in the current operating mode (heating or cooling). If there is no value stored from a previous heating or cooling cycle, the VFD speed initially sets to 75% or 8.0 VDC. After the VFD speed is initially set, the VFD control signal is not adjusted until after 90 seconds of compressor operation, and then is periodically checked and adjusted every 10 seconds if needed to maintain the LAT.

If the control switches from the heating mode to cooling, or cooling to heating without de-activating the compressor, the VFD control voltage immediately switches to the last stored control voltage for the new operating mode, and is not adjusted for the first 90 seconds of operation in the new operating mode. The VFD control voltage is increased or decreased

incrementally based on the magnitude of the differential between the current LAT and the target LAT defined in the **Operating Temperatures** table.

DISCRETE SPEED VFD OPERATION

When the CXM2 is configured for discrete-speed VFD operation, the VFD speed is set to the selected operating speed (A, B or C) for full-load heating or cooling. Full-load operation is defined as second stage enabled in either heating or cooling.

When the CXM2 is configured for discrete-speed VFD operation, the VFD operating speed may be increased or decreased by 10%. The speed offset option defaults to normal (no offset). To increase the VFD operating speed by 10%, set the speed offset option to Increase. To decrease the VFD operating speed by 10%, set the speed offset option to decrease.

When operating in first-stage heating or cooling, the VFD speed is set to the percentage of the selected full-load operating speed (A, B or C, plus or minus adjustment) listed for each unit size as defined in the **Operating Temperatures** table.

Table 1: VFD Control Valves

Model	Minimum VFD Speed	Maximum VFD Speed	VFD Fixed Speed A	VFD Fixed Speed B	VFD Fixed Speed C	Part Load Multiplier	Default Fan Speed
MB072	3.7	10.0	7.4	6.2	9.0	71%	5.2
MB096	3.8	10.0	7.0	6.0	9.0	75%	5.0
MB120	4.2	10.0	8.0	7.0	9.0	70%	6.0
MB160	4.1	10.0	7.9	6.4	9.0	76%	5.4
MB192	4.4	10.0	8.0	7.0	9.0	73%	6.0
MB240	4.2	10.0	8.0	7.0	9.0	70%	6.0
MB300	5.0	10.0	8.0	8.0	9.5	71%	7.0

Table 2: Operating Temperatures

Model	Minimum Heat LAT	Maximum Heat LAT	Default Heat LAT	Minimum Cool LAT	Maximum Cool LAT	Default Cool LAT
MB072	85°	125°	105°	45°	65°	55°
MB096	85°	125°	105°	45°	65°	55°
MB120	85°	125°	105°	45°	65°	55°
MB160	85°	125°	105°	45°	65°	55°
MB192	85°	125°	105°	45°	65°	55°
MB240	85°	125°	105°	45°	65°	55°
MB300	85°	125°	105°	45°	65°	55°

LAT differential Actual – Target	VFD adjust (VDC)
$\Delta T \leq 1.0^\circ\text{F}$	0.0
$1.0 < \Delta T \leq 2.0^\circ\text{F}$	0.1
$2.0 < \Delta T \leq 3.0^\circ\text{F}$	0.2
$3.0 < \Delta T \leq 5.0^\circ\text{F}$	0.3
$\Delta T > 5.0^\circ\text{F}$	0.4

GENERAL

Furnish and install MB Compact High-Capacity Series units as indicated on the plans. Equipment shall be completely assembled, piped and internally wired. Capacities and characteristics as listed in the schedule and the specifications that follow.

Units shall be supplied completely factory built, capable of operating over an entering water temperature range from 20° to 120°F (-6.7° to 43.3°C) as standard. Equivalent units from other manufacturers may be proposed provided approval to bid is given 10 days prior to bid closing. All equipment listed in this section must be rated and certified in accordance with Air-Conditioning, Heating and Refrigeration Institute / International Standards Organization (AHRI / ISO 13256-1). All equipment must be tested, investigated, and determined to comply with the requirements of the standards for Heating and Cooling Equipment UL 60335-2-40 4th Edition, UL 60335-1 6th Edition for the United States and Can/CSA C22.2 No. 60335-2-40:22, CAN/CSA C22.2 No 60335-1:16 for Canada, by Intertek Testing Laboratories (ETL). The units shall have AHRI / ISO and ETL-US-C labels

All units shall pass a factory acceptance test. The quality control system shall automatically perform factory acceptance test via computer. A detailed report card from the factory acceptance test shall be shipped with each unit. **NOTE: If a unit fails the factory acceptance test, it shall not be allowed to ship. The unit serial number shall be recorded by factory acceptance test and furnished on report card for ease of unit warranty status.**

BASIC CONSTRUCTION

Horizontal units shall have one of the following air flow arrangements: Left Return/Back Discharge, Left Return/Straight Discharge, Right Return/Back Discharge, Right Return/Straight Discharge as shown on the plans. Unit sizes 072 to 120 can be field converted without requiring new panels or belts. **Unit sizes 072-120 that cannot be field converted shall not be acceptable.**

Vertical units shall have one of the following air flow arrangements: rear return/top discharge, front return/top discharge, rear return/front discharge, front return/rear discharge as shown on plans. Unit sizes 072-120 can be field converted without requiring new panels or belts. **Unit sizes 072-120 that cannot be field converted shall not be acceptable.**

If units with these arrangements are not used, the contractor is responsible for any extra costs incurred by other trades. All units must have a minimum of two access panels for serviceability of compressor compartment. **Units having only one access panel to compressor/heat exchangers/expansion device/refrigerant piping shall not be acceptable.**

Compressor-section interior surfaces shall be lined with ½-inch-thick (12.7 mm), 1½ lb/ft³ (24 kg/m³), acoustic-type, glass-fiber insulation. Air-handling-section interior surfaces shall be lined with ½-inch-thick (12.7 mm), 1¾ lb/ft³ (28 kg/m³) foil-backed glass-fiber insulation for ease of cleaning. Insulation placement shall be designed in a manner that will eliminate any exposed edges to prevent the introduction of glass fibers into the air stream. **Units without foil-faced insulation in the air-handling section will not be accepted.**

Units shall be fabricated from heavy-gauge galvanized steel with powder-coat finish on front access panels.

Standard insulation must meet NFPA Fire Hazard Classification requirements 25/50 per ASTM E84, UL 723, CAN/ULC S102-M88 and NFPA 90A requirements; air erosion and mold growth limits of UL-181; stringent fungal resistance test per ASTM-C1071 and ASTM G21; and shall meet zero level bacteria growth per ASTM G22. **Unit insulation must meet these stringent requirements or unit(s) will not be accepted.**

Horizontal units to have discharge flange, 1-inch (25.4 mm), 2-inch (50.8 mm), or 4-inch (101.6 mm) return filter rails with filters factory installed, and factory-installed hanger brackets. Vertical units have discharge flange shipped loose and 1-inch (25.4 mm), 2-inch (50.8 mm), or 4-inch (101.6 mm) return full filter frame with filters factory installed. **If units with these factory installed provisions are not used, the contractor is responsible for any extra costs to field install these provisions, and/or the extra costs for their subcontractor to install these provisions.**

All units must have an insulated panel separating the fan compartment from the compressor compartment. Units with the compressor in the air stream are not acceptable.

Horizontal units shall have factory-installed filter rails with filter removal from either side. Vertical units shall have factory-installed full-filter frame with filter removal from bottom. **The contractor shall purchase one spare set of filters and replace factory shipped filters on completion of startup.** Filters shall be standard sizes. **If units utilize non-standard filter sizes then the contractor shall provide 12 spare filter sets for each unit.**

Cabinets shall have separate knockouts on front and sides for entrance of line voltage and low-voltage control wiring. All factory-installed wiring passing through factory knockouts and openings shall be protected from sheet-metal edges at openings by plastic ferrules. Supply and return water connections shall be copper FPT fittings, connections on either the left or right side and shall be securely mounted flush to the cabinet side allowing for connection of a flexible hose without the use of a backup wrench. **Water connections that protrude through the cabinet or require the use of a backup wrench shall not be allowed.** Water connections on only one side will not be accepted. All water connections and electrical knockouts must not interfere with the serviceability of unit. **Contractors shall be responsible for any extra costs involved in the installation of units that do not have this feature.** Contractors must ensure that units can be easily removed for servicing and coordinate locations of electrical conduit and lights with the electrical contractor.

Option: Dual-point power.

Option: Sound Attenuation package shall consist of high-technology sound-attenuating material that is strategically applied to the compressor and air-handling compartment casings and fan scroll in addition to the standard system design, to further dampen and attenuate sound transmissions. Compressor is mounted on specially engineered sound-tested isolators.

Option: The unit will be supplied with internal factory-mounted modulating water valve with delta T control. The factory built-in valve shall modulate water flow through unit based on a field-adjustable water temperature difference between the entering and leaving water. The valve shall automatically adjust for operating mode, source water temperature and variations in external head pressure. The valve will also act as a shutoff valve to prevent water flow through the unit when the unit is not activated and will have a minimum position capability. Externally mounted, modulating water valves will not be accepted.

Option: The unit will be supplied with internally factory-mounted two-way water valve for variable-speed pumping requirements. A factory-mounted (included with factory-mounted water valve) or field-installed high-pressure switch shall be installed in the water piping to disable compressor operation in the event water pressures build due to water freezing in the piping system.

FAN AND MOTOR ASSEMBLY

All units shall have a single belt-driven centrifugal fan. Fan motor shall be premium duty, VFD compatible, permanently lubricated with thermal-overload protection. Units supplied without permanently lubricated motors must provide external oilers for easy service. The fan and motor assembly must be capable of overcoming the external static pressures as shown on the schedule. Airflow/Static pressure rating of the unit shall be based on a wet coil and a clean filter in place. **Ratings based on a dry coil and/or no filter, or on an ESP less than 0.25 inches (6.35 mm w.g.) shall NOT be acceptable.**

Option: Various blower drive packages for selectable static pressure/airflow.

Option: Variable Frequency Drives (VFD). VFD controls shall be factory mounted, installed and programmed. VFD controls have the capability to reduce airflow down to 37.5%. Products not containing factory-mounted VFD controls shall not be acceptable.

REFRIGERANT CIRCUIT

All units shall contain an R-454B sealed refrigerant circuit including a high-efficiency scroll compressor designed for heat-pump operation, a thermostatic expansion valve for refrigerant metering, an enhanced corrugated-aluminum lanced fin and rifled copper tube refrigerant-to-air heat exchanger, reversing valve, coaxial (tube-in-tube) refrigerant-to-water heat exchanger, and safety controls including a high-pressure switch, low-pressure switch (loss-of-charge), water coil low-temperature sensor, and air coil low-temperature sensor.

Access fittings shall be factory installed on high and low-pressure refrigerant lines to facilitate field service. Activation of any safety device shall prevent compressor operation via a microprocessor lockout circuit. The lockout circuit shall be reset at the thermostat or at the contractor supplied disconnect switch. **Units that cannot be reset at the thermostat shall not be acceptable.**

The scroll compressors shall have a dual-level vibration isolation system. The compressor(s) will be mounted on specially engineered, sound-tested EPDM vibration-isolation grommets to a large heavy gauge compressor mounting plate, which is then isolated from the cabinet base with EPDM grommets to minimize vibration and maximize vibration attenuation. Compressor shall have thermal-overload protection. Compressors shall be located in an insulated compartment isolated from air stream to minimize sound transmission.

Refrigerant-to-air heat exchangers shall utilize enhanced corrugated lanced aluminum fins and rifled copper tube construction rated to withstand 625 PSIG (4,309 kPa) refrigerant working pressure. Refrigerant-to-water heat exchangers shall be of copper inner water tube and steel refrigerant outer tube design, rated to withstand 625 PSIG (4,309 kPa) working refrigerant pressure and 300 PSIG (2,068 kPa) working water pressure. The refrigerant-to-water heat exchanger shall be "electro-coated" with a low-cure cathodic epoxy material a minimum of 0.4 mils thick (0.4 – 1.5 mils range) on all surfaces. The black-colored coating shall provide a minimum of 1,000 hours of salt-spray protection per ASTM B117-97 on all external steel and copper tubing. The material shall be formulated without the inclusion

of any heavy metals and shall exhibit a pencil hardness of 2H (ASTM D3363-92A), crosshatch adhesion of 4B-5B (ASTM D3359-95), and impact resistance of 160 in-lbs (184 kg-cm) direct (ASTM D2794-93).

The unit water circuit is protected by two high-pressure switches set at 300 PSI (2,068 kPa). Switches will reset automatically when pressure is reduced. Units that do not have auto-reset water high-pressure switches are not acceptable.

Refrigerant metering shall be accomplished by thermostatic expansion valve only. Expansion valves shall be dual-port balanced type with external equalizer for optimum refrigerant metering. Units shall be designed and tested for operating ranges of entering water temperatures from 20° to 120°F (-6.7° to 48.9°C). A reversing valve shall be a four-way solenoid-activated refrigerant valve, which shall default to heating mode should the solenoid fail to function. If the reversing-valve solenoid defaults to cooling mode, an additional low-temperature thermostat must be provided to prevent over-cooling an already cold room.

Individual refrigeration circuits charged with 62 ounces or greater of R-454B shall be supplied with a Refrigerant Detection System (RDS) with sensors to be strategically placed within the cabinet. In the event of a refrigerant leak, the RDS disables compressor operation, and the unit blower runs to disperse any concentration of leaked refrigerant in compliance with UL 60335-2-40 safety standards for flammable refrigerants. **Individual refrigeration circuits charged with 62 ounces or greater of R-454B that do not have an RDS shall not be acceptable.**

Option: The unit shall be supplied with extended range insulation option, which adds closed cell insulation to internal water lines, and provides insulation on suction side refrigeration tubing including refrigerant-to-water heat exchanger.

Option: The refrigerant-to-air heat exchanger shall be coated.

Option: The unit shall be supplied with a WSE. The WSE will consist of hydronic coil, three-way valve, and aquastat. The aquastat will be adjustable type and factory set at 45°F (7.2°C).

Option: The unit will be supplied with a cupronickel coaxial water-to-refrigerant heat exchanger.

DRAIN PAN

The drain pan shall be constructed of galvanized steel and have a powder-coat paint application to further inhibit corrosion. This corrosion protection system shall meet the stringent 1,000-hour salt spray test per ASTM B117. If plastic-type material is used, it must be HDPE (High-Density Polyethylene) to avoid thermal-cycling shock-stress failure over the lifetime of the unit. Drain pans shall be fully insulated. Drain pan outlet shall be located to ensure positive unobstructed drainage of condensate. Drain outlet for horizontal units shall be connected from pan directly to 3/4-inch FPT fitting. For vertical units, drain pan hose assembly can be connected to either side, drain outlet to be 1-inch FPT fitting. The unit as standard will be supplied with solid-state electronic condensate overflow protection. **Mechanical float switches will NOT be accepted.**

Option: The unit shall be supplied with stainless-steel drain pan.

ELECTRICAL

A control box shall be located within the unit compressor compartment and shall contain a 75 VA transformer with load side circuit breaker protection, 24V activated, two- or three-pole compressor contactor, terminal block for thermostat wiring, and solid-state controller for complete unit operation. Reversing valve and fan motor wiring shall be routed through this electronic controller. Units shall be name-plated for use with time-delay fuses or HACR circuit breakers. Unit controls shall be 24-volt and provide heating or cooling as required by the remote thermostat/sensor. Units shall have a solid-state time-delay relay and random start to prevent both compressors from starting simultaneously.

ENHANCED SOLID-STATE CONTROL SYSTEM (CXM2)

Units shall have a solid-state control system. **Units utilizing electro-mechanical control shall not be acceptable.** The control system microprocessor board shall be specifically designed to protect against building electrical system noise contamination, EMI, and RFI interference. The control system shall interface with a heat-pump-type thermostat. The control system shall have the following features:

- a. Anti-short cycle time delay on compressor operation.
- b. Random start on power up mode.
- c. Low-voltage protection.
- d. High-voltage protection.
- e. Unit shutdown on high- or low-refrigerant pressures.
- f. Unit shutdown on low water temperature.
- g. Condensate overflow electronic protection.
- h. Option to reset unit at thermostat or disconnect.
- i. Automatic intelligent reset. Unit shall automatically reset the unit 5 minutes after trip if the fault has cleared. If a fault occurs 3 times sequentially without thermostat meeting temperature, then lockout requiring manual reset will occur.
- j. Ability to defeat time delays for servicing.
- k. The low-pressure switch shall not be monitored for the first 120 seconds after a compressor start command to prevent nuisance safety trips.
- l. 24V output to cycle a motorized water valve or other device with compressor contactor.
- m. Unit Performance Sentinel (UPS). The UPS warns when the heat pump is running inefficiently.
- n. Water coil low-temperature sensing (selectable for water or anti-freeze).
- o. Air coil low-temperature sensing.
- p. Minimized reversing-valve operation (Unit control logic shall only switch the reversing valve when cooling is demanded for the first time. The reversing valve shall be held in this position until the first call for heating, ensuring quiet operation and increased valve life).

- q. Emergency shutdown contacts.
- r. Entering- and leaving-water temperature sensing.
- s. Leaving-air temperature sensing.
- t. Compressor-discharge temperature sensing.

NOTE: Units not providing the eight safety protections of anti-short cycle, low-voltage, high-voltage, high-refrigerant pressure, low-pressure (loss of charge), air coil low temperature cut-out, water coil low temperature cut-out, and condensate overflow protections will not be accepted.

When CXM2 is connected to a Wireless Service Tool, the installer/service technician can; check DIP switch S2 settings; run operation modes manually; check all physical inputs from the Wireless Service Tool and refrigerant pressure switches status, (Y1, Y2, W, O, G, H, ESD, NSB, OR, HP switch, and LOC switch); current or at time of fault the following temperatures—water coil (LT1), air coil (LT2), compressor discharge, leaving air, leaving water, entering water and control voltage; record last five faults, list possible reasons, and clear faults.

DIGITAL NIGHT SETBACK WITH PUMP RESTART:

The unit will be provided with a digital night-setback feature using an accessory relay on the CXM2, an external, field-provided thermostat, and an external, field-provided time clock. The external time clock will initiate and terminate the night-setback period. The thermostat will have a night-setback override feature with a programmable override time period. An additional accessory relay on the unit CXM2 will energize the building-loop pump control for the duration of the override period.

NOTE: This feature requires additional low-voltage wiring. Consult Application Drawings for details.

REMOTE SERVICE SENTINEL

Solid-state control system shall communicate with a service tool to display (on the service tool) the unit status, fault status, and specific fault condition, as well as retrieve previously stored fault that caused unit shutdown. The Remote Service Sentinel allows building maintenance personnel or service personnel to

diagnose units from the service tool. The control board shall provide a signal to the service tool fault light, indicating a lockout. Upon cycling the G (fan) input three times within a 60-second time period, the fault light shall display the specific code as indicated by a sequence of flashes. A detailed flashing code shall be provided at the service tool to display unit status and specific fault status such as over-/under-voltage fault, high-pressure fault, low-pressure fault, low-water-temperature fault, condensate-overflow fault, etc.

Units that do not provide this remote service sentinel shall not be acceptable.

Option: MPC (Multiple Protocol Control) Interface System

Units shall have all the features listed above and the control board will be supplied with a Multiple Protocol interface board. Available protocols are BACnet MS/TP, Modbus, or Johnson Controls N2. The choice of protocol shall be field-selectable/changeable via the use of a simple selector switch. **Protocol selection shall not require any additional programming or special external hardware or software tools.** This enables all units to be daisy-chain connected by a two-wire twisted-pair shielded cable. The following points must be available at a central or remote computer location:

- a. Space temperature
- b. Leaving-water temperature
- c. Discharge-air temperature
- d. Command-of-space temperature setpoint
- e. Cooling status
- f. Heating status
- g. Low-temperature sensor alarm
- h. Low-pressure sensor alarm
- i. High-pressure switch alarm
- j. Condensate-overflow alarm
- k. High-/low-voltage alarm
- l. Fan "ON/AUTO" position of space thermostat as specified above

- m. Unoccupied/occupied command
- n. Cooling command
- o. Heating command
- p. Fan "ON/AUTO" command
- q. Fault-reset command
- r. Itemized fault code revealing reason for specific shutdown fault (any one of seven)

This option also provides the upgraded 75VA control transformer with load side short circuit and overload protection via a built-in circuit breaker.

FIELD-INSTALLED OPTIONS

Hose Kits:

All units 120,000 Btuh (35 kW) and below shall be connected with hoses. The hoses shall be 2-foot-long (61-cm), braided stainless steel; fire-rated hoses complete with adapters. **Only fire-rated hoses will be accepted.**

Valves:

The following valves are available and will be shipped loose:

- a. Ball valve; bronze material, standard port full flow design, FPT connections.
- b. Ball valve with memory stop and PT port.
- c. "Y" strainer with blowdown valve; bronze material, FPT connections.
- d. Motorized water valve; slow-acting, 24V, FPT connections.

Hose Kit Assemblies:

The following assemblies ship with the valves already assembled to the hose described:

- a. Supply and return hoses having ball valve with PT port.
- b. Supply hose having ball valve with PT port; return hose having automatic flow regulator valve with PT ports, and ball valve.
- c. Supply hose having "Y" strainer with blowdown valve, and ball valve with PT port; return hose having automatic flow regulator with PT ports, and ball valve.

- d. Supply hose having "Y" strainer with blowdown valve, and ball valve with PT port; return hose having ball valve with PT port.

THERMOSTATS

The thermostat shall be a geothermal mechanical or electronic type thermostat.

NOTE: All units require a heat pump thermostat with two-stage cooling.

WIRELESS SERVICE TOOL

Allows installation and service personnel to access the configuration and service modes of the CXM2:

- a. Configure the airflow, pump, or modulating valve operation etc.
- b. Diagnose by viewing fault history and operating conditions at the time of fault and manually operating the unit.

DDC SENSORS

Wall-mounted DDC sensor to monitor room temperature and interfaces with optional interface system described above. Several types as described below:

- a. Sensor only with no display (MPC).
- b. Sensor with setpoint adjustment and override (MPC only).
- c. Sensor with setpoint adjustment and override, LCD display, status/fault indication (MPC).

NOTICE

This product specification document is furnished as a means to copy and paste our product information into project specification. It is not intended to be a complete list of product requirements. This document is an excerpt from the product submittal and must not be used without consulting the complete product submittal. For complete product installation and application requirements, please consult the complete product submittal. Heat Controller is not responsible for misuse of this document or a failure to adequately review specific requirements in the product catalog.

Revision History

Models:
MB
072-300

Date	Section	Description
03/25/26	Features, Options, and Accessories	Added the cupronickel heat exchanger option
	Model Nomenclature	Updated
	Dimensional Data MB072-120 Horizontal	Updated header column names
	Dimensional Data MB072-120 Horizontal with WSE	Updated header column names
	Engineering Specifications	Added the cupronickel heat exchanger option
10/01/25	Internal Variable Water Flow Control	Added section
	Model Nomenclature	Updated model nomenclature including product revision
	Performance Data: AHRI/ASHRAE/ISO 13256-1	Updated
	Performance Data	Updated
	Blower Performance	Added Standard MB300 performance
	Electrical Data	Updated the following for Standard and Dual Point Power units: <ul style="list-style-type: none"> • Min/max voltage columns • Added data for additional voltage options for size 240-300 models
		Added horsepower and kW values for Standard MB300 units
	Physical Data	Added weights for units with WSE (packaged and unpackaged)
		Updated MWV and MOD valve working water pressures
Blower Motor Variable Frequency Drive (VFD) Controls (Optional)	Updated example VFD image	
Engineering Specifications	Added water options	
06/16/25	All, Blower Motor Variable Frequency Drive (VFD) Controls	Updated ACU01/Handheld Service tool to Wireless Service Tool

Due to ongoing product improvements, specifications, and dimensions are subject to change and correction without notice or incurring obligations. Determining the application and suitability for use of any product is the responsibility of the installer. Additionally, the installer is responsible for verifying dimensional data on the actual product prior to beginning any installation preparations.

Incentive and rebate programs have precise requirements as to product performance and certification. All products meet applicable regulations in effect on date of manufacture; however, certifications are not necessarily granted for the life of a product. Therefore, it is the responsibility of the applicant to determine whether a specific model qualifies for these incentive/rebate programs.



1900 Wellworth Ave. | Jackson, MI 49203
Phone: 517-787-2100
www.heatcontroller.com

