Comfort-Cire®

Century®

SE Series

Multi-Position Aluminum Cased Coils

MAA*****S1A

Instruction Manual





RECOGNIZE THIS SYMBOL AS AN INDICATION OF IMPORTANT SAFETY INFORMATION

⚠ WARNING

These instructions are intended as an aid to qualified licensed service personnel for proper installation, adjustment and operation of this unit. Read these instructions thoroughly before attempting installation or operation. Failure to follow these instruction may result in improper installation, adjustment, service or maintenance possibly resulting in fire, electrical shock, property damage, personal injury or death.

⚠ WARNING

Proposition 65: This appliance contains fiberglass insulation. Respirable particles of fiberglass are known to the state of California to cause cancer. For more information, go to www.P65Warnings.ca.gov.”

CONTENTS

1 SAFETY	01
2 GENERAL	
• 2.1 Unit Dimensions	01
• 2.2 Codes & Regulations	02
• 2.3 Inspection Upon Unit Arrival	02
• 2.4 Clearances	02
3 INSTALLATION INSTRUCTIONS	
• 3.1 Replacement Parts	03
• 3.2 Pre-installation Instruction	03
• 3.3 Installation And Trap Connection	03
4 DRAIN APPLICATION	
• 4.1 Condensate Drain Piping	05
• 4.2 Plastic Drain Pan Installation	05
5 REFRIGERANT CONNECTIONS	06
6 PISTION/TXV INSTALLATION	
• 6.1 Piston Installation	06
• 6.2 Optional TXV Kit Installation	07
7 AIR FLOW PERFORMANCE	08

1 SAFETY

⚠ WARNING

Disconnect all power to the unit before starting any service and maintenance. Failure to do so could cause severe electrical shock resulting in personal injury or death.

Installation or servicing of this unit can be hazardous due to parts, components and system pressure.

Qualified and proper trained service personnel should perform installation and repair. Failure to do so could cause severe electrical shock resulting in personal injury or death.

This is a safety alert symbol indicating a potential hazardous situation, which could result in personal injury, property and/or product damage or death.

⚠ CAUTION

This is a safety alert symbol indicating a potential hazardous situation, which could result in moderate personal injury, and/or property and product damage.

2 GENERAL

The coil can be positioned for bottom return air in the upflow and horizontal right applications. It must be positioned for top return when in downflow and horizontal left applications. See figure 2-1. For furnace applications, the coil must be installed downstream (in the air outlet) of the furnace

💡 NOTE

This coil comes with a factory-installed heat shield on the drain pan.

2.1 Unit Dimensions

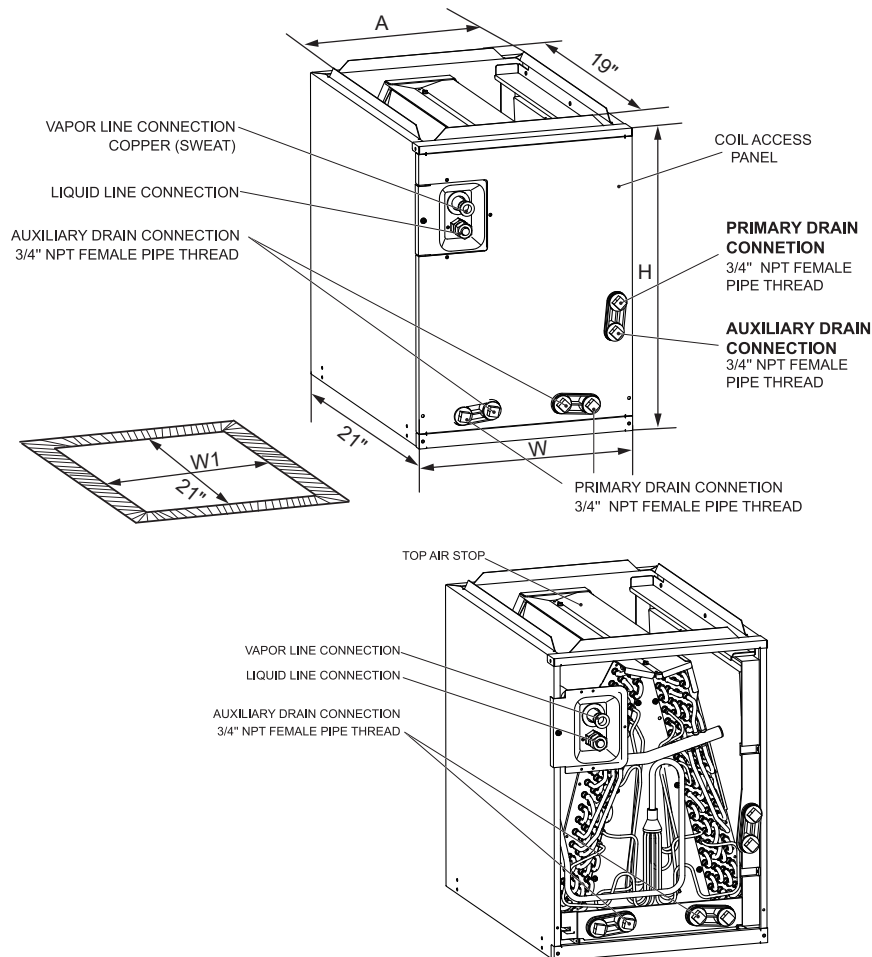

Fig.2-1 CASED DIMENSIONS AND COMPONENT LOCATION

DIMENSIONAL DATA

MODELS	Unit Dimensions					WEIGHT (LBS.[kg])
	UNIT HEIGHT "H" IN. [mm]	UNIT WIDTH "W" IN. [mm]	SUPPLY DUCT "A" IN. [mm]	"W1" IN. [mm]	LIQUID LINE/ VAPOR LINE	
MAA1836AS1A	20"[508]	14-1/2"[368]	13"[330]	13-1/2"[343]	3/8" / 3/4"	46[21]
MAA1836BS1A	20"[508]	17-1/2"[445]	16"[407]	16-1/2"[419]	3/8" / 3/4"	49[22]
MAA1836CS1A	20"[508]	21"[533]	19-1/2"[495]	20"[508]	3/8" / 3/4"	51[23]
MAA1842BS1A	26"[660]	17-1/2"[445]	16"[407]	16-1/2"[419]	3/8" / 7/8"	60[27]
MAA1842CS1A	26"[660]	21"[533]	19-1/2"[495]	20"[508]	3/8" / 7/8"	62[28]
MAA3642DS1A	26"[660]	24-1/2"[622]	23"[584]	23-1/2"[597]	3/8" / 7/8"	66[30]
MAA3042BS1A	30"[762]	17-1/2"[445]	16"[407]	16-1/2"[419]	3/8" / 7/8"	73[33]
MAA3042CS1A	30"[762]	21"[533]	19-1/2"[495]	20"[508]	3/8" / 7/8"	73[33]
MAA3648DS1A	30"[762]	24-1/2"[622]	23"[584]	23-1/2"[597]	3/8" / 7/8"	77[35]
MAA3660CS1A	30"[762]	21"[533]	19-1/2"[495]	20"[508]	3/8" / 7/8"	82[37]
MAA4260DS1A	30"[762]	24-1/2"[622]	23"[584]	23-1/2"[597]	3/8" / 7/8"	86[39]

2.2 Codes & Regulations

This product is designed and manufactured to comply with national codes.

Installation in accordance with such codes and/or prevailing local codes/regulations is the responsibility of the installer. The manufacturer assumes no responsibility for equipment installed in violation of any codes or regulations.

The United States Environmental Protection Agency(E-PA) has issued various regulations regarding the introduction and disposal of refrigerants. Failure to follow these regulations may harm the environment and can lead to the imposition of substantial fines. Should you have any questions please contact the local office of the EPA.

2.3 Inspection Upon Unit Arrival

As soon as unit is received, it should be inspected and noted for possible shipping damage during transportation. Report and damage immediately

2.4 Clearances

Following clearances should be provided during installation

- Maintenance and service access, including coil cleaning and coil assembly removal
- Refrigerant piping and connections
- Condensate drain line

Ensure the proper installation, Select a solid and level site.

Ensure enough space required for installation and maintenance.

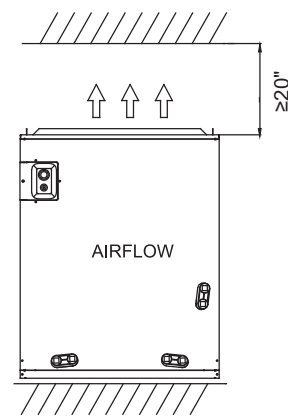

Fig. 2-2 Front view of the indoor unit clearance (including air duct)

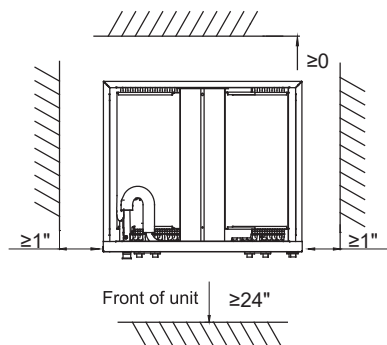

Fig. 2-3 Top View of the indoor unit clearance (including air duct)

3 INSTALLATION INSTRUCTIONS

3.1 Replacement Parts

Contact your distributor for authorized replacement parts.

3.2 Pre-installation Instruction

Carefully read all instructions for installation prior to installing product. Make sure each step or procedure is understood and any special considerations are taken into account before starting installation. Assemble all tools, hardware and supplies needed to complete the installation. Some items may need to be purchased locally.

Make sure everything needed to install the product is on hand before starting.

3.3 Installation And Trap Connection

1. See Fig. 3-1 for coil installation and drain connection.

2. Installation steps for cased coil:

A. Shut off or disconnect gas furnace's power and remove gas pipe if necessary;

B. Disconnect and remove a sufficient portion of the supply ductwork to provide clearance for the cased coil.

C. Ensure that the coil is leveled well and seal the gap between coil and furnace.

See Fig. 3-1. In case that coil and furnace sizes are not matched, use proper size of sheet metal or other material to fill the gap and seal the gap to prevent air leak;

D. Reconnect the ductwork to the coil case, and seal any leakage;

E. Reconnect Power line on gas furnace, turn on the furnace to check any sign of leakage.

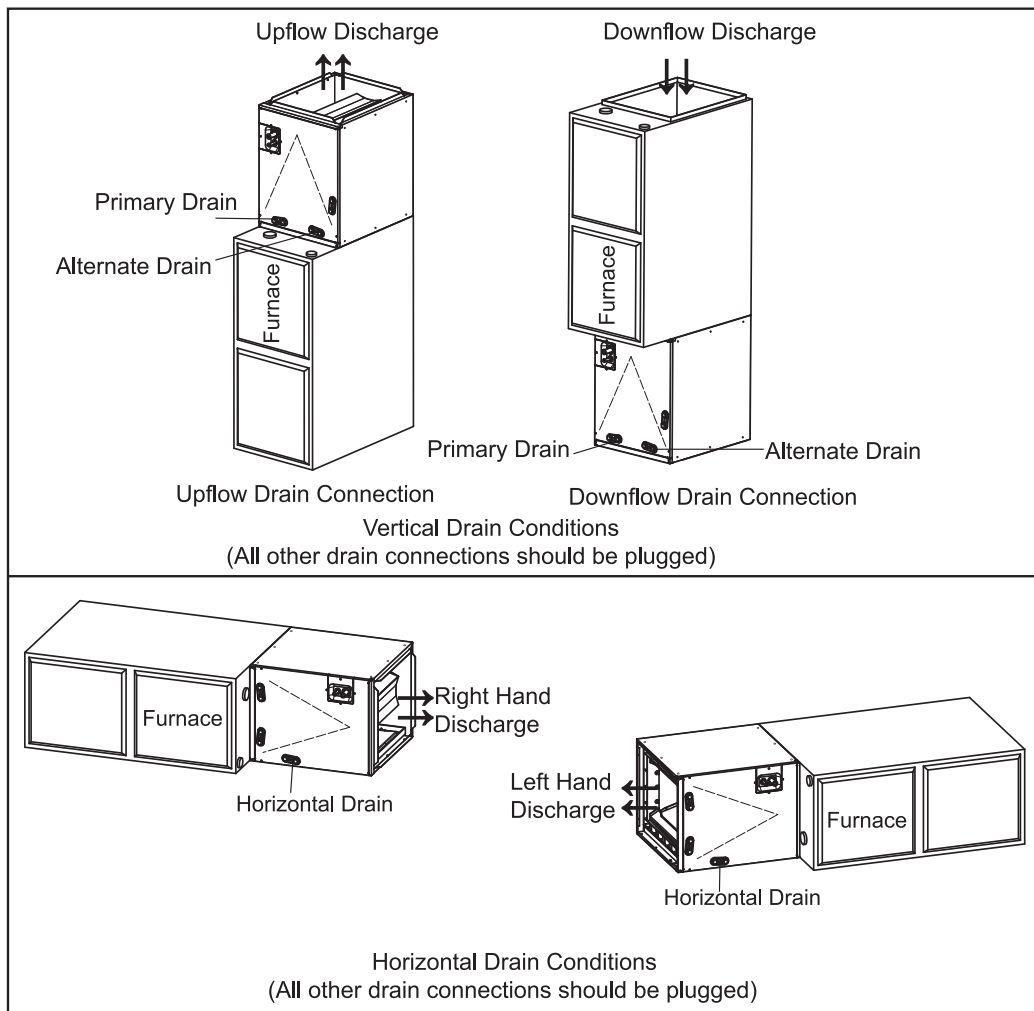

Fig. 3-1 INSTALLATION OF CASSED COIL

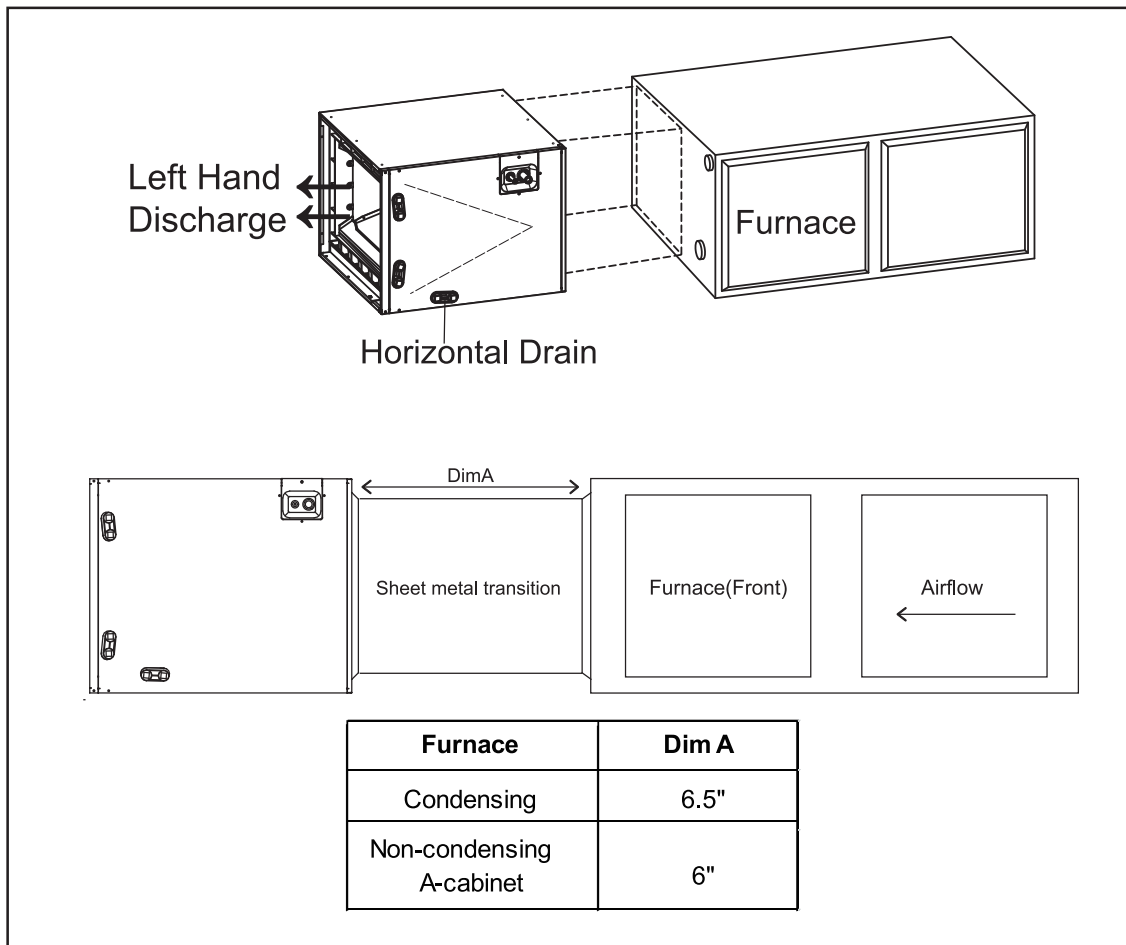

Fig. 3-2 Transition for horizontal left orientation

3. If the coil is used in connection with an upflow furnace in horizontal left orientation, a sheet metal transition can be installed between the furnace supply air outlet and the evaporator coil supply air inlet to create clearance between coil lineset and furnace flue outlet for A-cabinet non-condensing furnaces and for all cabinet size condensing furnaces. See Fig. 3-2

For A-cabinet non-condensing furnaces, a 6" transition is needed.

For all cabinet size condensing furnaces, a 6.5" transition is needed.

If space is a constraint, the lines/flue interference can be removed by rotating the coil such that the lineset is facing the opposite direction and air flow through the bottom of the A-coil, thus optimizing airflow.

4 DRAIN APPLICATION

4.1 Condensate Drain Piping

Consult local codes for special requirements.

To provide extra protection from water damage, it is always recommended to install an additional drain pan, provided by installer under the entire unit with a separate drain line. Manufacturer will not be responsible for any damages due to the failure to follow these recommendations.

4.2 Plastic Drain Pan Installation

⚠ WARNING

Do not use the coil pan shipped with the unit on OIL furnaces or any application where the temperature of the drain pan may exceed 275° F. A field fabricated metal drain pan can also be used for these type of applications.

Failure to follow this warning may result in property damage and/or personal injury.

💡 NOTE

Use Teflon tape on the drain line connections. Do not use pipe joint compound or PVC/CPVC cement on drain nipple.

The coil drain pan has a primary and an optional secondary drain with 3/4" NPT female connections; use either PVC or copper pipe and hand tighten to a torque of approximately 37 in-lbs. to prevent damage to the drain pan connection. An insertion depth between 0.355 to 0.485 inches (3-5 turns) should be expected at this torque setting.

Use male 3/4" NPT threaded fitting for outside connection and make sure the drain holes are not blocked.

Insulation may be needed for drain line to prevent sweating.

Drain pan has two drain connections on each side to provide flexibility of connection and drainage. Make sure pan has proper pitch and plugged if second connection is not used.

If the secondary drain line is required, run the line separately from the primary drain and terminate it where it can be easily seen.

💡 NOTE

Water coming from this line means the coil primary drain is plugged and needs clearing.

Install a trap in the drain line below the bottom of the drain pan. If using a copper drain line, solder a short piece of pipe to the connector before installing a drain fitting. DO NOT over torque the 3/4" copper connector to the plastic drain connection. Use a wet rag or heatsink material on the short piece to protect plastic drain pan, complete the rag or heatsink material on the short piece to protect plastic drain pan, complete the drain line installation (Fig. 4-1). Use (Fig. 4-2) as a template for typical drain pipe routing.

This figure shows how to avoid interference with vent piping.

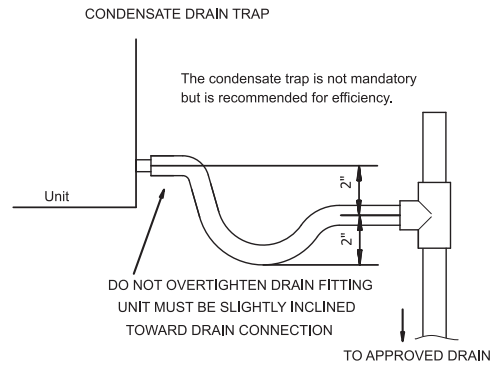

Fig. 4-1 DRAIN LINE INSTALLATION

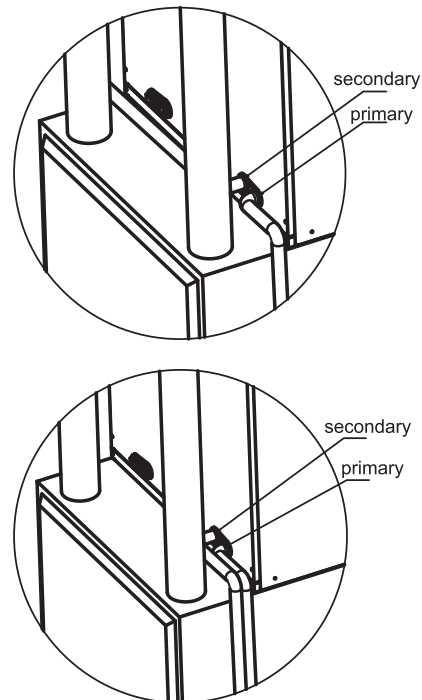

Fig. 4-2 DRAIN PIPE ROUTING

5 REFRIGERANT CONNECTIONS

⚠ CAUTION

Gently remove the sealing plug of vapor line, use one wrench to fix valve base, loose the nut with another wrench, take out the flange pad and sealing ring.

To prevent refrigerant leak, use proper tools to ensure clean, burr-free cut.

⚠ CAUTION

TXV bulb **MUST** be protected (wrapped with wet rag) or removed, while brazing the tubing. Overheating of the sensing bulb will affect the functional characteristics and performance of the coil.

Use brazing shield when brazing close to the cabinet surface and wet rag to protect rubber grommet.

Brazing alloy should be at least 5% silver content.

6 PISTON/TXV INSTALLATION

💡 NOTE

A piston does come pre-installed. The piston must be removed before installing a TXV.

6.1 Piston Installation

1. Using a wrench to loosen the nut. Remove the nut and sealing flange.
2. Check the piston sizes for each outdoor/coil combination in Table 6-1 and choose the correct piston size for your combination.
3. If a different size piston is needed for your system combination, remove the pre-installed piston.

💡 NOTE

Avoid pulling the piston sleeve out when removing the pre-installed piston.

4. Choose correct size piston from the doc pack and insert it in correct orientation.
5. Replace outer O-ring with the O-ring provided in the doc pack.
6. Attach the connection pipe with nut and tighten to 1/6th turn past hand-tighten.

💡 NOTE

MUST wrap the nut with a wet rag before brazing.

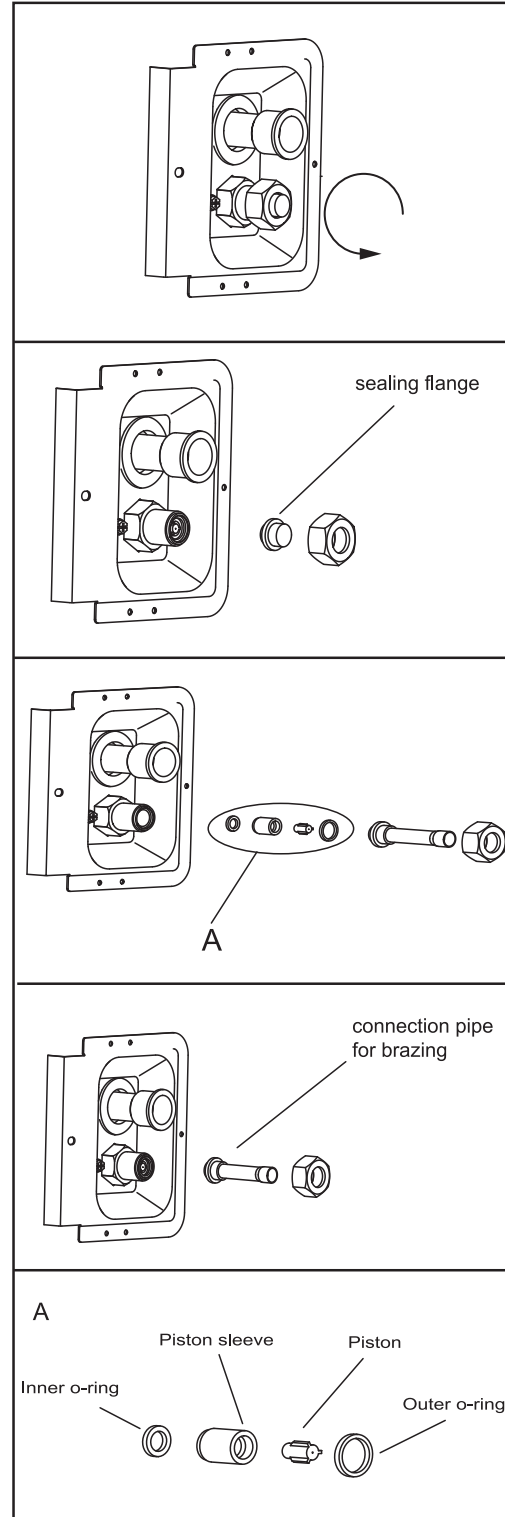

Fig 6-1

This coil comes with a factory installed piston metering device. See Table 6-1 for factory installed piston size. Some system combinations will require a different sized piston to be field installed.

* Use the piston size recommended by the outdoor unit if available.

* Reference Table 6-2 If the outdoor unit dose not list a piston size.

* The literature bag will contain additional R-410A pistons for most applications.

* Contact your local parts center to order the appropriate piston if it is not included with the literature.

6.2 Optional TXV Kit Installation

Reference TXV kit literature for installation instructions.

1. Use a wrench to loosen the nut and remove the sealing flange and sealing gasket.
2. Take out the connecting pipe from accessory package and braze the connecting pipe onto the refrigeration-out pipe.
3. Install the sealing washers, TXV and flange connection tube.
4. Use a wrench fasten nut and connecting pipe. (18±2N·m).
5. Connect TXV equalizer pipe to the port on the connecting pipe.
6. Fix bulbs on the connecting pipe using use accessory in TXV kit.

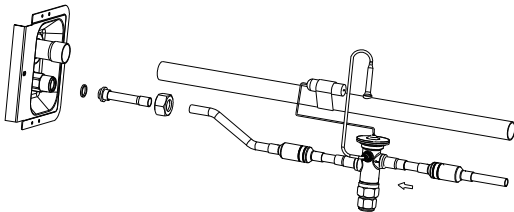

Fig 6-2

A TXV may be required to achieve minimum efficiency ratings or for long refrigerant line set applications. Reference AHRI for system combination ratings.

Reference Table 6-2 to charge the system by superheat when using piston.

Reference the outdoor unit installation guide to charge the system when using a TXV.

Table 6-1 Factory installed piston size for each coil model. Additional piston sizes are provided in the ship-with literature bag as necessary.

MAA	Piston/orifice sizes												
Model	50	52	56	58	60	64	68	70	73	75	80	83	90
1836A		X		X	X	X*		X					
1836B		X		X	X	X*		X					
1836C		X		X	X	X*		X					
1842B		X			X	X		X		X*			
1842C					X	X		X		X*			
3642D					X	X		X		X*			
3042B				X		X		X		X		X*	
3042C						X		X		X		X*	
3648D								X		X		X*	
3660C										X	X	X	X*
4260D										X	X	X	X*

* means that this piston is pre-installed

⚠ WARNING

Failure to install the proper piston can lead to poor system performance and possible compressor damage.

⚠ CAUTION

An improperly charged system will likely cause loss in system performance and may damage the compressor.

Table 6-2 Piston superheat charging chart

Outdoor temp(°F)	Indoor Temperature(°F) Dry Bulb/Wet Bulb					
	95/79	90/75	85/71	80/67	75/63	70/58
	Superheat					
115	23	16	7	5	5	5
110	24	17	9	5	5	5
105	26	19	11	5	5	5
100	27	21	13	7	5	5
95	29	23	16	9	5	5
90	30	25	18	12	5	5
85	35	26	20	14	8	5
80	34	28	22	17	11	5
75	35	30	24	19	13	6
70	37	32	26	21	16	10
65	38	34	29	24	19	13
60	40	36	31	27	22	17
55	41	37	33	29	25	21

💡 NOTE

Chart is based on 400CFM/Ton indoor airflow and 50% relative humidity. If indoor relative humidity is above 70% or below 20%, use indoor wet bulb temperature only. Airflow range is 375 to 425 CFM/Ton

7 AIR FLOW PERFORMANCE

Airflow performance [CFM VS Pressure drop]

Pressure drop characteristics for cooling and heat pump coils								
Pressure drop (Inches of water)								
Model	0.05	0.1	0.15	0.2	0.25	0.3	0.35	0.4*
MAA1836AS1A	307	485	618	729	823	911	991	1063
MAA1836BS1A	327	527	682	810	925	1024	1122	1217
MAA1836CS1A	360	585	748	893	1019	1132	1238	1348
MAA1842BS1A	401	600	773	916	1045	1160	1256	1357
MAA1842CS1A	457	663	856	1019	1156	1277	1394	1502
MAA3642DS1A	496	718	924	1102	1259	1398	1530	1651
MAA3042BS1A	456	638	810	953	1077	1191	1284	1390
MAA3042CS1A	505	726	932	1098	1244	1375	1494	1604
MAA3648DS1A	533	857	1105	1319	1509	1675	1824	1956
MAA3660CS1A	439	699	906	1071	1224	1362	1487	1589
MAA4260DS1A	466	764	978	1157	1313	1466	1590	1695

Data based on wet coil with entering air at 80 degF DB / 67 degF WB without air filter.
 The maximum allowable pressure drop is 0.4 IWG.
 The maximum CFM is the data at 0.4 IWG pressure.

Maximum airflow setting

 **NOTE**

Water blow-off could occur in certain installation positions if the airflow setting exceeds the maximum values listed.

Maximum airflow setting (CFM)				
Model	Upflow	Horizontal Left	Downflow	Horizontal Right
MAA1836AS1A	1200	1050	1050	1200
MAA1836BS1A	1250	1200	1050	1250
MAA1836CS1A	1250	1200	1050	1250
MAA1842BS1A	1575	1400	1400	1575
MAA1842CS1A	1575	1400	1400	1575
MAA3642DS1A	1575	1450	1450	1575
MAA3042BS1A	1800	1800	1700	1500
MAA3042CS1A	1800	1800	1700	1700
MAA3648DS1A	1800	1800	1700	1700
MAA3660CS1A	1850	1750	1750	1850
MAA4260DS1A	2000	1850	1850	2000



SE SERIES LIMITED WARRANTY

Congratulations on purchasing your new HVAC equipment.

Your unit automatically qualifies for the warranty coverage listed below provided you meet the warranty conditions.

YEAR 1 PRODUCT REPLACEMENT

If the heat exchanger, evaporator coil (packaged systems only), condenser coil, or compressor fails within the first year (365 days) after the date of installation to the original consumer for the original installation, the original purchase cost of the unit will be reimbursed to the authorized Comfort-Aire/Century distributor who has received prior authorization from Comfort-Aire/Century for the failure. The owner is responsible for additional labor, freight, and miscellaneous charges. Units installed in a commercial application, defined as any application other than a residential/multifamily (personal, family or household) purpose, are not eligible for the one year product replacement.

LIMITED WARRANTY

All parts are warranted to be free from defects in workmanship and materials for normal residential use and maintenance for five (5) years from the date of purchase by the original consumer for the original residential installation. The compressor and the heat exchanger are warranted to be free from defects in workmanship and materials for normal residential use and maintenance for ten (10) years from the date of purchase by the original consumer for the original residential installation.

LIMITED EXTENDED WARRANTY

When registered with Comfort-Aire/Century, the heat exchanger is warranted to be free from defects in material and workmanship for twenty (20) years and all parts are warranted to be free from defects in material and workmanship for ten (10) years from the date of purchase by the original consumer for the original installation.

DURATION OF WARRANTY

The warranty begins on the date of purchase by the original consumer (homeowner). The original consumer must retain a receipted bill of sale or invoice showing model and serial number as proof of the warranty period initiation.

CONDITIONS FOR WARRANTY COVERAGE

Unit must be properly installed and maintained by a licensed HVAC service provider in accordance with the installation, operation, and maintenance instructions provided with each unit. Unit cannot have been subjected to accident, alteration, improper repair, neglect/misuse, or force majeure. Proof of proper maintenance over the lifetime of the unit must be supplied. Performance cannot be impaired by use of any product not authorized by Comfort-Aire/Century, or by any adjustments or adaptations to components. Serial numbers and/or rating plate have not been altered or removed. Damage has not been a result of inadequate wiring or voltage conditions, use during brown-out conditions, or circuit interruptions. Unit remains in the original residential installation and is not transferrable. Unit was not purchased over the internet or at auction. Non-approved refrigerant and/or non-approved system additives will void this warranty.

WARRANTY EXCEPTIONS

The Limited Express Warranty does not cover costs associated with normal maintenance, utility usage, labor, shipping and handling, or collateral damage. It also does not cover any portion or component of the system that is not supplied by Comfort-Aire/Century, regardless of the cause of failure of such portion or component.

LIMITATION OF LIABILITY

There are no other express or implied warranties. Comfort-Aire/Century makes no warranty of merchantability and does not warrant that the unit is suitable for any particular purpose, building, room size, or condition except as specifically provided in this document. There are no other warranties, express or implied, which extend beyond the description in this document. All warranties implied by law are limited in duration to the five-year term of the Parts Warranty. Your exclusive remedy is limited to the replacement of defective parts. Comfort-Aire/Century will not be liable for any consequential or incidental damages caused by any defect in this unit. This warranty gives you specific legal rights and you may also have other rights which vary from state to state. Some states do not allow a limitation on how long an implied warranty lasts or do not allow the exclusion or limitation of incidental or consequential damages, so the above limitations or exclusions may not apply to you. No warranties are made for units sold outside the continental United States and Canada. Your distributor or final seller may provide a warranty on units sold outside these areas. Comfort-Aire/Century will not be liable for damages if our performance regarding warranty resolution is delayed by events beyond our control including accident, alteration, abuse, war, government restrictions, strikes, fire, flood, or force majeure.



Please visit www.heatcontroller.com to register your new product.

KEEP THIS INFORMATION AS A RECORD OF YOUR PURCHASE

Apply Serial Number and Model Number sticker here (from product carton). If unavailable, write serial number and model number below (can be found on unit rating plate).

Date of Purchase _____ Date Installation Completed _____

Component of new HVAC system Replacement furnace only

Remember to retain your bill of sale as proof of warranty period and ownership.

Due to ongoing product improvements, specifications and dimensions are subject to change and correction without notice or incurring obligations. Determining the application and suitability for use of any product is the responsibility of the installer. Additionally, the installer is responsible for verifying dimensional data on the actual product prior to beginning any installation preparations.

Incentive and rebate programs have precise requirements as to product performance and certification. All products meet applicable regulations in effect on date of manufacture; however, certifications are not necessarily granted for the life of a product. Therefore, it is the responsibility of the applicant to determine whether a specific model qualifies for these incentive/rebate programs.

