



A2L CCG / MCG Coils

Installation Instructions

TABLE OF CONTENTS	PAGE
General	1
Condensate Drain	2
Multi-Position	2-3
Metering Device	5
Refrigerant Line Installation	6
Refrigerant Charging Instructions	6
Coil Cleaning.....	6
Warranty	7-8
Installation Check List	8



Evaporator Coil Safety

SAFETY CONSIDERATIONS

Your safety and the safety of others are very important.

We have provided many important safety messages in this manual and on your appliance. Always read and obey all safety messages.



This is the safety alert symbol.

This symbol alerts you to potential hazards that can kill or hurt you and others.

All safety messages will follow the safety alert symbol and signal word. These signals words mean the following:

DANGER: You can be killed or seriously injured if you don't immediately follow instructions.

WARNING: Indicate a potentially hazardous situation which, if not avoided, could result in death or serious injury.

CAUTION: Indicates a potentially hazardous situation which, if not avoided, may result in minor or moderate injury. Caution may also be used to alert against unsafe practices.

NOTICE: Indicates a statement of company policy as the message relates directly or indirectly to the safety of personnel or protection of property.

IMPORTANT: More detailed information concerning the statement of company policy as the message relates directly or indirectly to the safety of personnel or protection of property.





CAUTION





This appliance is not intended for use by persons (including children) with reduced physical, sensory or mental capabilities, or lack of experience and knowledge, unless they have been given supervision or instruction concerning use of the appliance by a person responsible for their safety. Children should be supervised to ensure that they do not play with the appliance.





Evaporator Coil Safety

 **IMPORTANT** 



This unit is a PARTIAL UNIT AIR CONDITIONER, complying with PARTIAL UNIT requirements of this Standard, and must only be connected to other units that have been confirmed as complying to corresponding PARTIAL UNIT requirements of this Standard, UL 60335-2-40/CSA C22.2 No. 60335-2-40, or UL 1995/CSA C22.2 No 236.

 **IMPORTANT** 



The Clean Air Act of 1990 bans the intentional venting of refrigerant (CFC's and HFC's). Approved methods of reclaiming must be followed. Fines and/or incarceration may be levied for non-compliance.

 **IMPORTANT** 



This unit is a PARTIAL UNIT, it shall only be connected to an appliance using the same refrigerant as listed in the name plate of this unit.

 **NOTICE** 

Leak detection system Installed. Unit must be powered except for service

 **CAUTION** 

Some soaps used for leak detection are corrosive to certain metals. Carefully rinse the piping thoroughly after leak test has been completed. Do not use matches, candles, flame or other sources of ignition to check for gas leaks.

 **IMPORTANT** 

In addition to conventional charging procedures, the following requirements shall be followed.



1. Ensure that contamination of different refrigerants does not occur when using charging equipment. Hoses or lines shall be as short as possible to minimize the amount of refrigerant contained in them.
2. Cylinders shall be kept in an appropriate position according to the instructions.
3. Ensure that the REFRIGERATION SYSTEM is earthed before charging the system with refrigerant.
4. Label the system when charging is complete
5. Extreme care shall be taken not to overfill the REFRIGERATION SYSTEM. Prior to recharging the system, it shall be pressure-tested with appropriate purging gas. The system shall be leak-tested on completion of charging but prior to commissioning. A follow-up leak test shall be carried out prior to leaving the site.

 **CAUTION** 

Any service personnel installing, decommissioning, or performing maintenance on the unit must be properly trained with A2L refrigerants



 **NOTICE** 

Sealed electrical components shall be replaced, not repaired.



 **NOTICE** 

Intrinsically safe components shall be replaced, not repaired.



 **WARNING** 

Do not use means to accelerate the defrosting process or to clean other than those recommended by the manufacturer. The appliance shall be stored in a room without continuously operating ignition sources (for example: open flames, an operating gas appliance or an operating electric heater. Do not pierce or burn. Be aware that refrigerants may not contain an odor.

 **CAUTION** 

Equipment shall be labeled stating that it has been decommissioned and emptied of refrigerant. The label shall be dated and signed. For appliances containing flammable refrigerants, ensure that there are labels on the equipment stating the equipment contains flammable refrigerant.

 **NOTICE** 

Ensure that the cabling is not subject to wear, corrosion, excessive pressure, vibration, sharp edges or any other adverse environmental effects.



 **NOTICE** 

This unit incorporates an earth connection for functional purposes only.



Evaporator Coil Safety

 **IMPORTANT** 



Work shall be undertaken under a controlled procedure so as to minimize the risk of a flammable gas or vapor being present while the work is being performed.

 **NOTICE** 



All maintenance staff and others should avoid working in confined spaces.

 **IMPORTANT** 



The area shall be checked with an appropriate refrigerant detector prior to and during work, to ensure the technician is aware of potentially toxic or flammable atmospheres. Ensure that the leak detection equipment being used is suitable for use with all applicable refrigerants, i.e. non-sparking, adequately sealed or intrinsically safe.

 **IMPORTANT** 



If any hot work is to be conducted on the refrigerating equipment or any associated parts, appropriate fire extinguishing equipment shall be available to hand. Have a dry powder or CO2 fire extinguisher adjacent to the charging area.

 **CAUTION** 

No person carrying out work in relation to a refrigerating system which involves exposing any pipe work shall use any sources of ignition in such a manner that it may lead to the risk of fire or explosion. All possible ignition sources, including cigarette smoking, should be kept sufficiently far away from the site of installation, repairing, removing and disposal, during which refrigerant can possibly be released to the surrounding space. Prior to work taking place, the area around the equipment is to be surveyed to make sure that there are no flammable hazards or ignition risks. "No Smoking" signs shall be displayed.



 **IMPORTANT** 

Ensure that the area is in the open or that it is adequately ventilated before breaking into the system or conducting any hot work. A degree of ventilation shall continue during the period that the work is carried out.



 **IMPORTANT** 

Where electrical components are being changed, they shall be fit for the purpose and to the correct specification. At all times the manufacturer's maintenance and service guidelines shall be followed. If in doubt, consult the manufacturer's technical department for assistance. The following checks shall be applied to installations using FLAMMABLE REFRIGERANTS as applicable.

1. The actual refrigerant charge is in accordance with the room size within which the refrigerant containing parts are installed.
2. The ventilation machinery and outlets are operating adequately and are not obstructed.
3. If an indirect refrigerating circuit is being used, the secondary circuit shall be checked for the presence of refrigerant.
4. Markings to the equipment continues to be visible and legible. Markings and signs that are illegible shall be corrected
5. Refrigerating pipe or components are installed in a position where they are unlikely to be exposed to any substance which may corrode refrigerant containing components, unless the components are constructed of materials which are inherently resistant to being corroded or are suitably protected against being so corroded.

 **CAUTION** 

Repair and maintenance to electrical components shall include initial safety checks and component inspection procedures such as that capacitors are discharged in a safe manner to avoid possibility of sparking, that no live electrical components and wiring are exposed while charging, recovering, or purging the system, and that there is continuity of earth bonding. If a fault exists that could compromise safety, then no electrical supply shall be connected to the circuit until it is satisfactorily dealt with. If the fault cannot be corrected immediately but it is necessary to continue operation, an adequate temporary solution shall be used that is reported to the owner of the equipment, so all parties are advised.

 **IMPORTANT** 

Improper installation, adjustment, alteration, service or maintenance can cause property damage, personal injury or loss of life. Installation and service must be performed by a licensed professional HVAC installer or equivalent, service agency, or the gas supplier.

Evaporator Coil Safety

WARNING

Auxiliary devices which may be a potential ignition source shall not be installed in the duct work. Examples of such potential ignition sources are hot surfaces with a temperature exceeding 700°C and electric switching devices.

NOTICE

All maintenance staff and others working in the local area shall be instructed on the nature of work being carried out with work in confined spaces being avoided.

WARNING

For appliances using A2L refrigerants connected via an air duct system to one or more rooms, only auxiliary devices approved by the appliance manufacturer or declared suitable with the refrigerant shall be installed in connecting ductwork.

WARNING

For duct connected appliances, false ceilings or drop ceilings may be used as a return air plenum if a REFRIGERANT DETECTION SYSTEM is provided in the appliance and any external connections are also provided with a sensor immediately below the return air plenum duct joint.

WARNING

If this appliance is conditioning a space with an area smaller than the TA_{min} as defined by instructions, then that space must be without continuously operating open flames (e.g. an operating gas appliance) or other potential ignition sources (e.g. an operating electric heater or similar hot surface). A flame producing device may be installed in the same space if the device is provided with an effective flame arrest system.

WARNING

It is the installers responsibility to ensure that the Q_{min} air flow rate requirement presented on TA_{min} , Q_{min} table is met when pairing ADP coils with OEM equipment.

Evaporator coils using A2L refrigerants (R-454B & R-32) installed at building site ground level altitude, must comply with a minimum conditioned area requirements are show below.

TA_{min} Table							
R-454B/ R-32 Refrigerant Charge (lbs)	3	5	10	15	20	25	30
R-454B/ R-32 Refrigerant Charge (kg)	1.4	2.3	4.5	6.8	9.1	11.3	13.6
MINIMUM CONDITIONED AREA (ft²)	45	75	150	225	300	375	450
MINIMUM CONDITIONED AREA (m²)	4.2	7.0	13.9	20.9	27.9	34.8	41.8
MINIMUM AIR FLOW RATE Q_{min} (m³/Hr)	138	230	460	689	919	1149	1379
MINIMUM AIR FLOW RATE Q_{min} (CFM)	81	135	270	406	541	676	811

Minimum conditioned area requirements must be adjusted by multiplying with the altitude adjustment factor (AF) for installation at higher altitudes (H_{alt}). Tables shown below lists the AF values for different altitudes in meters.

ALTITUDE ADJUSTMENT FACTOR													
H_{alt} (METERS)	0 - 600	800	1000	1200	1400	1600	1800	2000	2200	2400	2600	3000	3200
AF	1.00	1.02	1.05	1.07	1.10	1.12	1.15	1.18	1.21	1.25	1.28	1.36	1.40

GENERAL

Evaporator coils are designed for use with AC condensing units or heat pump units. These instructions are intended as a general guide and do not supersede local codes in any way. Consult with local authorities having jurisdiction before installation. **Read this installation manual and all safety messages prior to installing the evaporator coil.**

Check coil for shipping damage and verify the contents of the box containing the evaporator coil. If you should find damage, immediately contact the last carrier. Verify the efficiency performance requirements, such as SEER2, EER2, and/or HSPF2, are appropriate with the matched condensing or heat pump units. Check outdoor unit manufacturer for proper line sizing. **Coils are shipped with a 10 psi dry air holding charge. Puncture rubber plug on suction line to release charge before removing plugs.** The absence of pressure does not verify a leak. Check the coil for leaks before installing or returning it to your wholesaler.

Position the coil on the outlet of the furnace using sheet metal screws. In horizontal installations, the coil should be pitched approximately 1/2" toward the drain connections. **NOTE:** Sloping over 5/8" may cause blow off into the auxiliary drain hole in high static situations. Drain pans are made of a polymer that can withstand temperatures up to 450°F. **Maintain a 3" clearance on oil or drum type heat exchangers and 1½" on sectionalized heat exchangers. See Specification Guide for recommended downflow applications.** Refer to Specification Guide for limitations.



DO NOT BRAZE ANY LINE SETS without reviewing the Refrigerant Detection System Kit Installation manual for specific requirements on primary and secondary joints within the installed spaces.

NOTICE

Pipe-work including piping material, pipe routing, and installation shall include protection from physical damage in operation and service, and be in compliance with national and local codes and standards, such as ASHRAE 15, ASHRAE 15.2, IAPMO Uniform Mechanical Code, ICC International Mechanical Code, or CSA B52. All field joints shall be accessible for inspection prior to being covered or enclosed.

NOTICE

After completion of field piping for split systems, the field pipe-work shall be pressure tested with an inert gas to a minimum of 450 psig and then vacuum tested prior to refrigerant charging.

NOTICE

Field-made refrigerant joints indoors shall be tightness tested. The test method shall have a sensitivity of 5 grams per year of refrigerant or better under a pressure of at least 0.25 times the maximum allowable pressure. No leak shall be detected.

LOCATION AND CLEARANCE REQUIREMENTS

NOTICE

Maximum altitude of application is 3200 m above sea level.

MIN ENCLOSURE SIZE FOR UNCASED COILS			
	Front	Side	Back
DIM FROM DRAIN PAN	0.5"	0.5"	0.5"

SERVICE CLEARANCES			
	Front	Side	Back
CLEARANCES	6"	0"	0"

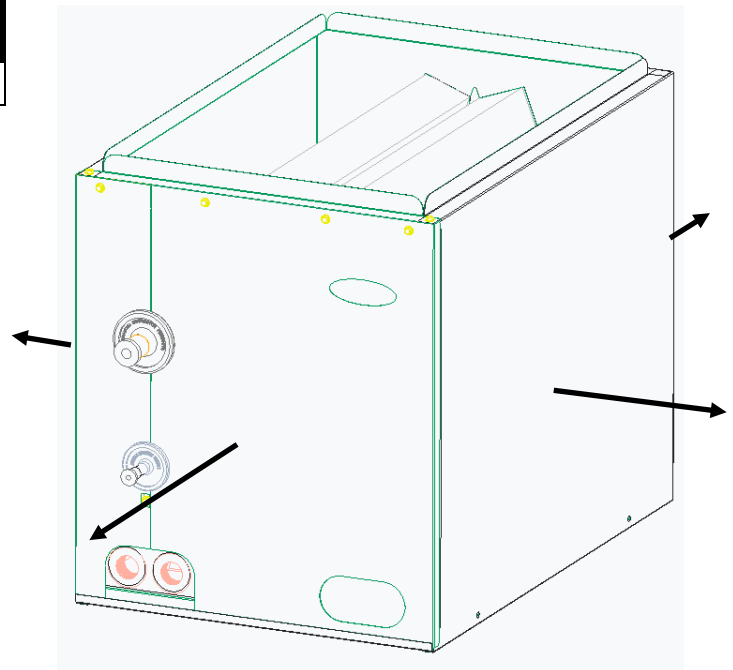

MCG MULTI-POSITION

Multi-Position A-Coils come factory installed with a vertical and horizontal drain pans and can be configured for upflow, downflow, horizontal blow-through or horizontal pull-through installations. In the center opening of vertical drain pan, a metal Inlet Air Restrictor is factory installed and is required for horizontal applications. It may be removed for vertical applications. **Airflow face velocity above 350 ft/min is not recommended for downflow or counterflow applications due to potential water blow-off.** Refer to Specification Guide for limitations.

For horizontal configurations, install splash guard (included) onto the coil outlet, and extend suction line insulation into the coil cabinet by 2" to prevent moisture from dripping onto the insulation (the rubber grommet may need to be moved). Splash guard installation is not required for vertical configurations. Bottom flange of guard should rest on pan and sides screwed to the duct flanges. See page 4, Figures 3 and 4 for splash guard instructions.

In downflow and counter flow configurations, aluminum foil tape must be applied to seal the top edge of the insulation to the cabinet. This tape will prevent the possibility of the insulation delaminating and blocking airflow. In horizontal pull-through and counter flow configurations, a minimum 12" transition is required in front of the coil as shown in Figure 1. This is required to ensure proper airflow distribution and to reduce pressure drop.

Coils that are 20" or less in height and are installed in a cabinet with a height of 25-1/2" or greater do not require a transition; all other coil models require this transition. Coil should be level, or pitched slightly toward the drain connection. It is recommended to add silicone caulk between drain pans to prevent water carryover. **Note: Multi-Position A-Coils are also field convertible from left-to-right or right-to-left; see page 5 for instructions on field conversion for horizontal airflow.**

Additional pre-startup checklist for Multi-Position A-Coils:

- Install splash guard (Figure 1 configurations A and B)
- Install 12" transition as shown (non-standard horizontal applications / Figure 1 configurations B and C)
- Factory installed Inlet Air Restrictor should be present in the center opening of the drain pan (horizontal applications)
- Factory installed internal water diverter should be in place (Figure 5, item 5)
- Extend suction line insulation into cabinet (counter flow)
- Tape top edge of insulation (counter flow)

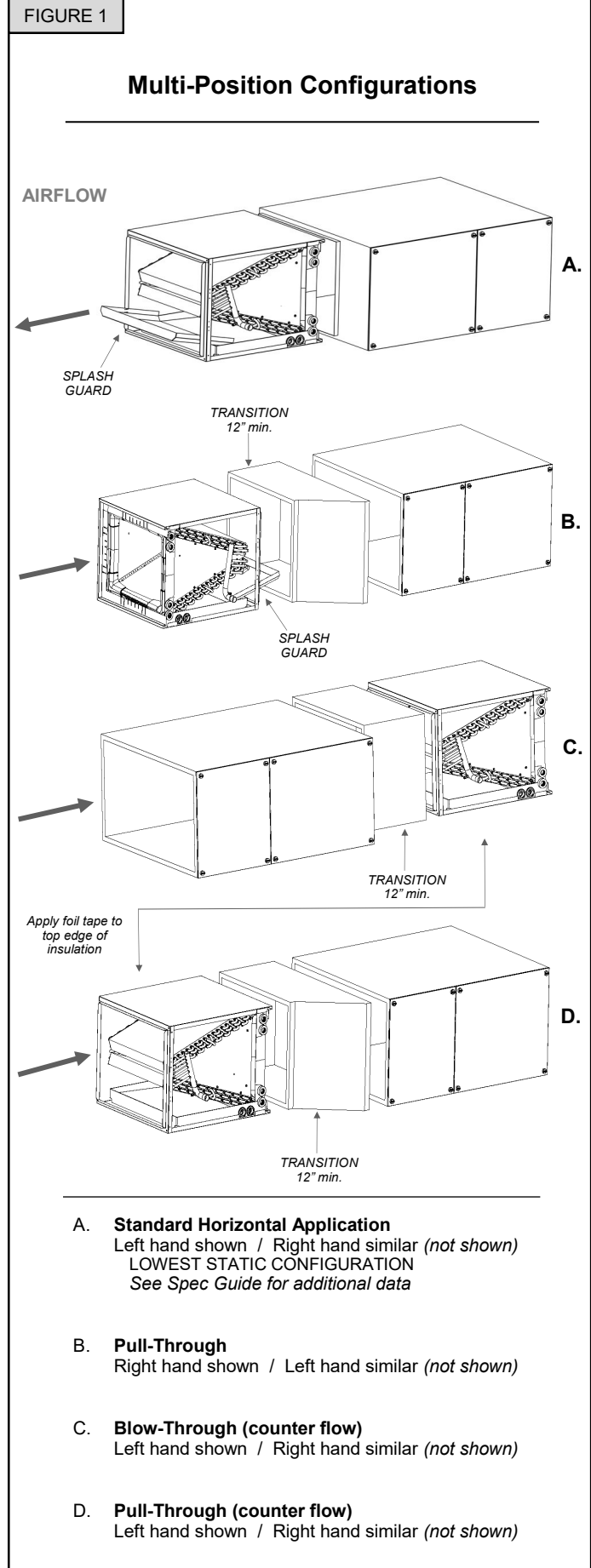

MCG MULTI-POSITION (field conversion) CONDENSATE DRAIN

Field Conversion Instructions from Left-to-Right or Right-to-Left Airflow

Note: This applies only to models available in multi-position; see Specification Guide for details; typical horizontal left-to-right conversion is shown.

FOR EACH STEP, REFER TO FIGURE 5:

1. Remove front panels.
2. Remove the top tie bar and pull the coil assembly from the housing.
3. Remove the horizontal drain pan, and re-install it to the opposite side of the coil (**Note:** horizontal drain pan must have drain plugs tightly closed in the rear of the unit).
4. Remove the top plate.
5. Remove the water diverter, and re-install it to the opposite slab (**Note:** If water diverter is attached by screws, remove screws, and bend tab straight or cut tab off).
6. Replace the top plate, and apply sealant to seal any air gaps.
7. Before re-inserting the coil assembly, cut the front flange on the housing and fold it back to allow access to the horizontal drain connections (**Note:** Copy the factory cut-out on the opposite side of the housing).
8. Slide the coil assembly back into the housing (**Note:** If unit is equipped with a sheet metal spacer, it must be moved to the opposite side of the housing).
9. Re-install the top tie bar.
10. Re-install the piping panel to the housing.
11. Cut a hole in the access panel to allow access to the horizontal drain connections, and re-install the access panel to the housing (**Note:** Access panel may need to be notched to allow access to suction header).
12. Seal unused condensate drain connection cutout holes in the front panel to prevent air leakage.

Coils are equipped with multiple drain connections. Determine the drain connections to be used and note the difference between the primary (green) and secondary (red) openings. Drain plugs are provided for all openings; remove and discard the appropriate plugs with 1/2" drive ratchet and verify that remaining plugs are tight (2.5 ft-lbs). Attach drain line to pan with 3/4" male pipe thread PVC fittings. Hand tight is adequate – **do not over tighten & do not reduce drain line size!**

Route drain(s) line so they will not be exposed to freezing temperatures and do not interfere with accessibility to the coil, air handling system or filter. The drain should be pitched downward 1" per 10' with a 2" trap as close to the coil as possible. If line makes a second trap, or has an extended run before termination, a vent tee should be installed after the trap closest to the pan. See Figure 2.

If the coil is located in or above a living space where damage may result from condensate overflow, a separate 3/4" drain must be provided from the secondary drain connection. Run this drain to a place in compliance with local installation codes where it will be noticed when unit is operational. Condensate flowing from the secondary drain indicates a plugged primary drain. Prime the trap with water. Test line for leaks. Test water flow with unit in operation. An auxiliary drain pan should be installed under the unit, and have a larger footprint than the coil, as specified by most local building codes.

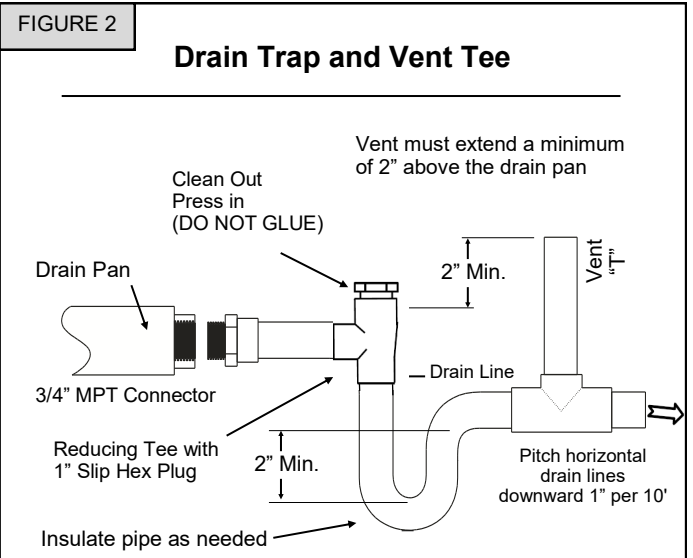

IMPORTANT

The Clean Air Act of 1990 bans the intentional venting of refrigerant (CFC's and HFC's). Approved methods of reclaiming must be followed. Fines and/or incarceration may be levied for non-compliance.

MCG MULTI-POSITION (splash guard)

FIGURE 3

Splashguard without Front Slope

Seal splashguard seams with silicone or other sealant.

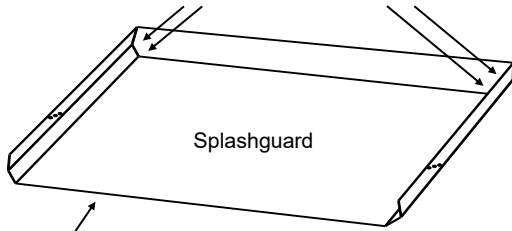

Open end of splashguard should rest on the horizontal drain pan.

Fasten splash guard to duct flanges with (4) sheet metal screws. (2) on each side. Screws can be installed from the inside or outside.

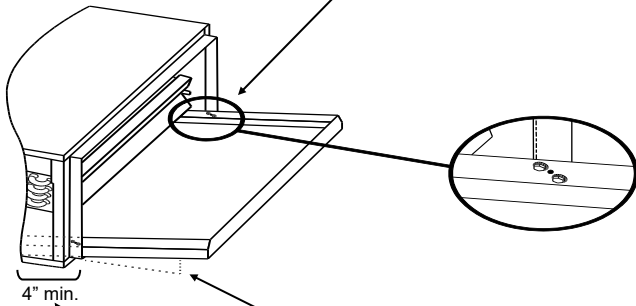

4" min.

Angle splashguard to ensure proper water drainage back into horizontal drain pan.

Splashguard should overlap the horizontal drain pan by at least 4".

FIGURE 4

Splashguard with Front Slope

Holes used to mount splashguard to duct flanges.

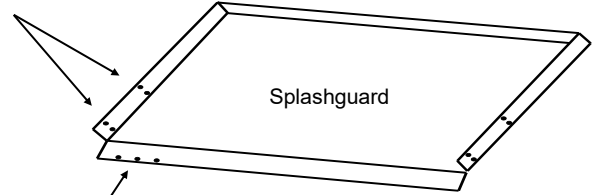

Caution: These holes are for manufacturing purposes only. **DO NOT** use for installation!

First set of mounting holes are used when horizontal drain pan is flush with housing.

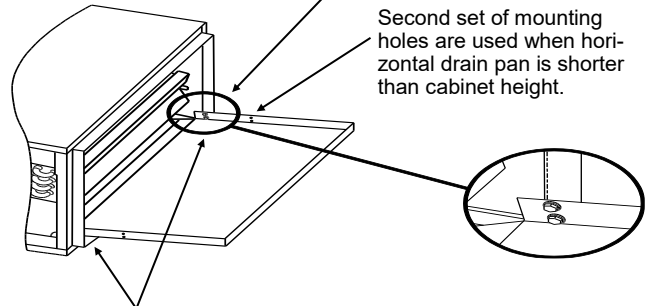

Second set of mounting holes are used when horizontal drain pan is shorter than cabinet height.

Fasten splash guard to duct flanges with (4) sheet metal screws. (2) on each side. Screws can be installed from the inside or outside.

FIGURE 5

Multi-Position Field Conversion

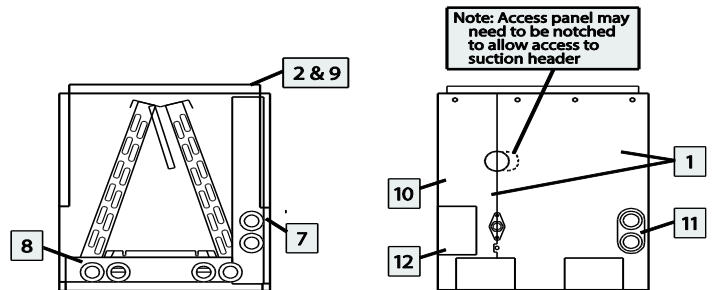
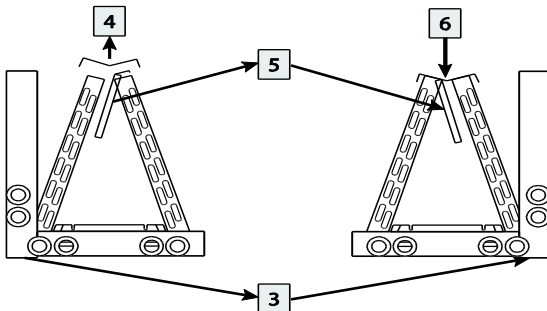

SUSPENDED COIL DETAIL



Suspended cabinet installation:

The suspending means must be field fabricated and should consist of a minimum of two "cradles" positioned at a distance symmetrically away from the centerline of the coil and design structure adequate to support the weight of the coil under operating condition. Example: Cradles may be made by attaching two 3/8" all thread rods to a length of 1-5/8" x 7/8" unistrut rods or equivalent. Adequate space must be provided in front of the coil panels for its removal and cradles should not interfere with panel removal, drain connections or refrigerant connections. Cradles should be at a minimum of 2" away from the edges of the coil.

METERING DEVICE

Coils are suited for R-32 and R-454B refrigerants and can be used with a piston or a TXV. Replacement TXV part numbers are listed below; see kit instructions for change out or installation. It is recommended to place a wet rag around the suction line at the cabinet during brazing to prevent overheating and damaging the sensing bulb.

For optimum performance, reattach and insulate the bulb at a 10 to 2 o'clock position outside of the cabinet to the main suction line no more than one foot from the suction line connection. If necessary, the bulb can be installed on a vertical suction line. In this instance, the bulb must be placed before any trap, with the bulb's capillary tube facing upward. When changing a system from AC to heat pump or heat pump to AC, check the current TXV specifications to determine if a TXV replacement is required. **If the evaporator coil contains a non-bleed TXV and is used with a condensing unit containing a reciprocating compressor, a hard start kit will be required on the condensing unit.**

R-32 TXV Part Numbers	
18-36 MBTUH A/C-HP	167758801A
42-60 MBTUH A/C-HP	167758802A

R-454B TXV Part Numbers	
18-36 MBTUH A/C-HP	26Z70
42-48 MBTUH A/C-HP	26Z71
60 MBTUH A/C-HP	26Z72

Cased coils with a piston metering device are shipped with a cap and hex nut over the threaded fitting. Remove the cap and nut slowly, allowing charge to escape, and secure the liquid line stub (attached to cabinet) to the distributor assembly with hex nut. Discard cap.

For optimum performance, the piston should be sized to match the recommendation from the outdoor unit manufacturer. If the outdoor unit manufacturer does not recommend a piston size, refer to the piston size chart. When changing pistons, refer to Figure 6 and use the following procedure:

1. Loosen hex nut located on liquid line and separate from distributor assembly.
2. Remove the existing piston from inside the distributor assembly.
3. Insert the desired piston into the distributor assembly.
4. Inspect Teflon O-Ring and replace if damaged. Ensure Teflon O-Ring is in place.
5. Re-install hex nut to body and torque to 10 ft-lbs.

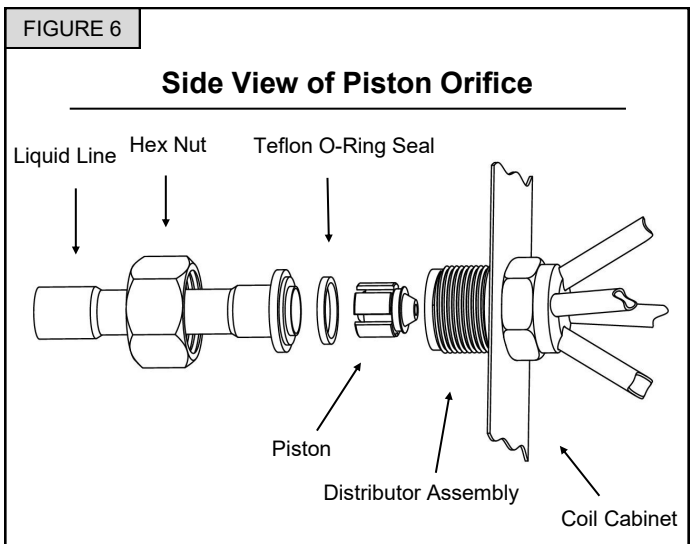

! **IMPORTANT** !

When changing the metering device, ensure the metering device matches the refrigerant type and capacity of the condensing unit. Failure to do so will result in poor performance and possible compressor damage. All coils must be matched properly as listed in the AHRI directory.

REFRIGERANT LINE INSTALLATION



DO NOT BRAZE ANY LINE SETS without reviewing the Refrigerant Detection System Kit Installation manual for specific requirements on primary and secondary joints within the installed spaces.

IMPORTANT

Evaporator primary line set joints in all applications shall have a refrigerant sleeve.

IMPORTANT

Evaporator primary line set joints should not have secondary joints.
If secondary joints are present, they shall be at least 2 feet away from the primary line set joints And comply with one of the option below.

It is recommended to install a filter drier and sight glass in the liquid line. While brazing, purge the system with Nitrogen to prevent contamination. It is recommended to reattach and insulate the TXV sensing bulb at a 10 to 2 o'clock position on the suction line, inside the coil housing. Evacuate the system to 500 microns to ensure proper air and moisture removal (**Note: Deep evacuation or triple evacuation method recommended**). Open the suction service valve slowly and

allow the refrigerant to bleed into the system before opening the liquid service valve.

FLAMMABLE REFRIGERANT DETECTION

Under no circumstances shall potential sources of ignition be used in the searching for or detection of refrigerant leaks.

A halide torch (or any other detector using a naked flame) shall not be used.

The following leak detection methods are deemed acceptable for all refrigerant systems.

Electronic leak detectors may be used to detect refrigerant leaks but, in the case of FLAMMABLE REFRIGERANTS, the sensitivity may not be adequate, or may need re-calibration. (Detection equipment shall be calibrated in a refrigerant-free area.) Ensure that the detector is not a potential source of ignition and is suitable for the refrigerant used. Leak detection equipment shall be set at a percentage of the LFL of the refrigerant and shall be calibrated to the refrigerant employed, and the appropriate percentage of gas (25 % maximum) is confirmed.

Leak detection fluids are also suitable for use with most refrigerants but the use of detergents containing chlorine shall be avoided as the chlorine may react with the refrigerant and corrode the copper pipe-work.

NOTE: Examples of leak detection fluids are

- bubble method,
- fluorescent method agents.

If a leak is suspected, all naked flames shall be removed/ extinguished.

If a leakage of refrigerant is found which requires brazing, all of the refrigerant shall be recovered from the system, or isolated (by means of shut off valves) in a part of the system remote from the leak. Removal of refrigerant shall be according to removal and evacuation procedure

REFRIGERANT CHARGING INSTRUCTIONS ¹

When charging in cooling mode, the outdoor temperature should be 60°F or higher. To allow the pressures to stabilize, operate the system a minimum of 15 minutes between adjustments. When adjusting charge to systems with micro-channel outdoor coils, make small (1 ounce or less) adjustments as these systems are very sensitive to refrigerant charge.

TXV Charging^{2,3,4} – Use the charging method recommended by the outdoor unit instructions. Alternatively, it is recommended to charge to 12°F sub-cooling for AC units and 10°F sub-cooling for heat pump units. In addition, if equipped with an adjustable valve, adjust to 10°F superheat.

Fixed Orifice Charging^{2,3,4} – For refrigerant installation use the superheat recommended by the outdoor unit instructions.

Outdoor Air Temp. (°F)	60	65	70	75	80	85	90	95	100	105	110	115
Superheat (°F)	31	28	25	22	20	16	13	10	8	6	5	5

For heat pump units initially charged in the cooling mode, final adjustments to charge in the heating mode are acceptable if necessary. Some heat pump units require charging in the heating mode. In this case, refer to the outdoor instructions for recommended charging procedures.

If the system is undercharged after the initial charge, add refrigerant until the sight glass is clear and recommended pressures, temperatures, sub-cooling and superheat can be obtained. If the system is overcharged after the initial charge, recover refrigerant until recommended pressures, temperatures, sub-cooling and superheat can be obtained.

Notes:

1. If any problems or questions regarding charge occur, contact customer service.
2. OEM charging methods vary depending on design and application. Verify all recommended pressures, temperatures, sub-cooling and superheat settings result in the proper charge.
3. Coils may require charge compensation due to size variation versus the OEM coil.
4. Temperatures are ±2°F unless otherwise recommended.

LABEL INSTALLATION

Permanently mark the serial label with the appropriate A2L (R-454B & R-32) refrigerant & metering device used. See example below.

REFRIGERANT: FACTORY CONFIGURED FOR R-454B
 ● FIELD INSTALLED AS R-454B
 ○ FIELD CONFIGURED TO R-32

METERING DEVICE
 ● TXV
 ○ PISTON

REFRIGERANT RECOVERY

Before carrying out work on systems containing refrigerant, it is essential that the technician is completely familiar with the equipment and all its detail. It is recommended good practice that all refrigerants are recovered safely. Prior to the task being carried out, an oil and refrigerant sample shall be taken in case analysis is required prior to re-use of recovered refrigerant. It is essential that electrical power is available before the task is commenced. Steps to ensure this are: becoming familiar with the equipment and its operation, isolating the system electrically, ensuring that before attempting the procedure that mechanical handling equipment is available, if required, for handling refrigerant cylinders, and that all personal protective equipment is available and being used correctly while the recovery process is supervised at all times by a competent person and that the recovery equipment and cylinders conform to the appropriate standards.

Additionally, pump down refrigerant system, if possible, and if a vacuum is not possible, make a manifold so that refrigerant can be removed from various parts of the system. Make sure that cylinders are situated on the scales before recovery takes place. Start the recovery machine and operate in accordance with instructions. Do not overfill cylinders (no more than 80 % volume liquid charge). Do not exceed the maximum working pressure of the cylinder, even temporarily. When the cylinders have been filled correctly and the process completed, make sure that the cylinders and the equipment are removed from site promptly and all isolation valves on the equipment are closed off. Recovered refrigerant shall not be charged into another refrigerating system unless it has been cleaned and checked.

When removing refrigerant from a system, either for servicing or decommissioning, it is recommended good practice that all refrigerants are removed safely. When transferring refrigerant into cylinders, ensure that only appropriate refrigerant recovery cylinders are employed. Ensure that the correct number of cylinders for holding the total system charge is available. All cylinders to be used are designated for the recovered refrigerant and labelled for that refrigerant (i.e. special cylinders for the recovery of refrigerant). Cylinders shall be complete with pressure-relief valve and associated shut-off valves in good working order. Empty recovery cylinders are evacuated and, if possible, cooled before recovery occurs.

The recovery equipment shall be in good working order with a set of instructions concerning the equipment that is at hand and shall be suitable for the recovery of the flammable refrigerant. If in doubt, the manufacturer should be consulted. In addition, a set of calibrated weighing scales shall be available and in good working order. Hoses shall be complete with leak-free disconnect couplings and in good condition.

The recovered refrigerant shall be processed according to local legislation in the correct recovery cylinder, and the relevant waste transfer note arranged. Do not mix refrigerants in recovery units and especially not in cylinders.

If compressors or compressor oils are to be removed, ensure that they have been evacuated to an acceptable level to make certain that flammable refrigerant does not remain within the lubricant. The compressor body shall not be heated by an open flame or other ignition sources to accelerate this process. When oil is drained from a system, it shall be carried out safely.

MAINTENANCE AND REPAIR INSTRUCTIONS

When breaking into the refrigerant circuit to make repairs – or for any other purpose – conventional procedures shall be used. However, for flammable refrigerants it is important that best practice be followed, since flammability is a consideration. Safely remove refrigerant following local and national regulations.

The refrigerant charge shall be recovered into the correct recovery cylinders if venting is not allowed by local and national codes. For appliances containing flammable refrigerants, the system shall be purged with oxygen-free nitrogen to render the appliance safe for flammable refrigerants. This process might need to be repeated several times. Compressed air or oxygen shall not be used for purging refrigerant systems.

For appliances containing flammable refrigerants, refrigerants purging shall be achieved by breaking the vacuum in the system with oxygen-free nitrogen and continuing to fill until the working pressure is achieved, then venting to atmosphere, and finally pulling down to a vacuum. This process shall be repeated until no refrigerant is within the system. When the final oxygen-free nitrogen charge is used, the system shall be vented down to atmospheric pressure to enable work to take place. Ensure that the outlet for the vacuum pump is not close to any potential ignition sources and that ventilation is available.

COIL CLEANING

The coils should be inspected and preferably cleaned a minimum of once a year or more often, if necessary. Cleaning of the indoor unit's coil should be performed by a licensed professional service technician (or equivalent).

1. Put on personal protective equipment – Safety glasses and/or face shield, waterproof clothing and gloves.
2. Vacuum or brush the coil to remove any matted or surface foreign debris from the fins (dirt, animal hair, etc).
3. Only clean potable water should be used to clean the coils. Clean coil slab surfaces by spraying steady and uniformly at a vertical angle of 30 to 45 degrees with a constant stream of water at moderate pressure (**less than 50 psig**) from top to bottom. A fan nozzle will work best. Do not spray the coil from a horizontal direction.

4. Use of acidic (below 5) or alkaline (above 9) cleaners can strip off factory protective coatings and reduce the life of an aluminum coil.
5. Alkaline (also called no-acid) coil cleaners are products that has a pH greater than 7. Acid coil cleaners are products that have a pH less than 7.

Note: Attempting to back flush from the inside of the coil will require removing parts from the unit, and it may be very difficult to flush the whole coil surface. Attempting to blow water through a coil will slow the water stream and reduce the *flushing action of the outer fin surface*.

INSTALLATION CHECKLIST

Downflow:

- <350 ft/min
- Tape top edge of insulation

Multi-Position:

- Complete additional checklist on page 3

Horizontal:

- Slope the coil approximately 1/2" toward the drain connections.

Metering Device:

- Verify and/or install correct TXV or piston

TXV Installation Only:

- Place TXV bulb at 10 to 2 o'clock position
- Insulate bulb
- Connect equalizer line

Charging:

- Charge per charging instructions

Drains:

- Install and trap primary and secondary condensate drains
- If over a finished space, install secondary drain pan

Air Path:

- Cover any unused knockouts

TERM OF WARRANTY

LIMITED FIVE (5) YEAR PARTS EXPRESS WARRANTY

All parts are warranted to be free from defects in workmanship and materials for normal residential use and maintenance for five (5) years from the date of purchase by the original consumer for the original residential installation, when the air handler or coil is installed in a non-AHRI matched system. This Limited Express Warranty applies only when the air handler or coil is installed per Comfort-Aire/Century installation instructions and in accordance with all local, state and national codes for normal residential use.

MATCHED SYSTEM LIMITED EXPRESS WARRANTY

When the air handler or coil is installed as part of a residential AHRI-matched system with a Comfort-Aire/Century air conditioning condenser or heat pump, the condenser or heat pump warranty applies to the air handler or coil under normal use and maintenance. Refer to the condenser or heat pump warranty for details, and register the product within 90 days of the purchase for the AHRI-matched system warranty.

EXCEPTIONS

The Limited Express Warranty does not cover normal maintenance—Comfort-Aire/Century recommends that regular inspection/maintenance be performed according to the Installation/Operation/Maintenance Manual. Additionally, labor charges, transportation charges for replacement parts, replacement of refrigerant or filters, any other service calls/repairs are not covered by this Limited Express Warranty. It also does not cover any portion or component of the system that is not supplied by Comfort-Aire/Century, regardless of the cause of failure of such portion or component.

CONDITIONS FOR WARRANTY COVERAGE

- Unit must be operated according to Comfort-Aire/Century operating instructions included with the unit and cannot have been subjected to accident, neglect or misuse, alteration, improper repair, or an act of God (such as a flood)
- Installation was done by a trained, licensed or otherwise qualified HVAC dealer/contractor
- Performance has not been impaired by use of any product not authorized by Comfort-Aire/Century, or by any adjustments or adaptations to components
- Serial numbers and/or rating plate have not been altered or removed
- Damage has not been a result of inadequate wiring or voltage conditions, use during brown-out conditions, or circuit interruptions
- Air flow around the unit has not been restricted
- Unit remains in the original residential installation
- Any extended warranty is valid to original purchaser only (non-transferable)
- Owner must supply proof of proper maintenance over the life of the unit
- Unit was not purchased over the internet

DURATION OF WARRANTY & REGISTRATION

With registration, the warranty begins on the date of purchase by the original consumer (homeowner). The original consumer must complete and return the warranty registration card or register at www.heatcontroller.com within 90 days of purchase. The original consumer must retain a receipted bill of sale as proof of warranty period. To receive the AHRI-matched system warranty, also retain proof of the AHRI-matched system installation (part numbers, serial numbers, purchase and installation dates). Without this proof, the warranty begins on date of shipment from the factory and reverts to the Five-Year Limited Express Parts Warranty.

REMEDY PROVIDED BY THE LIMITED EXPRESS WARRANTY

The sole remedy under the Limited Warranty is replacement of the defective part. If replacement parts are required within the period of this warranty, Comfort-Aire/Century replacement parts shall be used; any warranty on the replacement part(s) shall not affect the applicable original unit warranty. Labor to diagnose and replace the defective part is not covered by this Limited Express Warranty. Ready access to the unit for service is the owner's responsibility. If for any reason the replacement part/product is no longer available during the warranty period, Comfort-Aire/Century shall have the right to allow a credit in the amount of the current suggested retail price of the part/product instead of providing repair or replacement.

LIMITATION OF LIABILITY

1. EXCLUSION OF ALL IMPLIED WARRANTIES AND LIMITATION. There are no other express or implied warranties. Comfort-Aire/Century makes no warranty of merchantability. We do not warrant that the unit is suitable for any particular purpose or can be used in buildings or rooms of any particular size or condition except as specifically provided in this document. There are no other warranties, express or implied, which extend beyond the description in this document.
2. All warranties implied by law are limited in duration to the five-year term of the non-AHRI matched system Pars Warranty. Your exclusive remedy is limited to the replacement of defective parts. We will not be liable for any consequential or incidental damages caused by any defect in this unit.
3. This warranty gives you specific legal rights and you may also have other rights which vary from state to state. Some states do not allow limitation on how long an implied warranty lasts or do not allow the exclusion or limitation of incidental or consequential damages, so the above limitations or exclusions may not apply to you.

LIMITED WARRANTY

- No warranties are made for units sold outside the continental United States and Canada. Your distributor or final seller may provide a warranty on units sold outside these areas.
- Comfort-Aire/Century will not be liable for damages if our performance regarding warranty resolution is delayed by events beyond our control including accident, alteration, abuse, war, government restrictions, strikes, fire, flood, or other acts of God.

HOW TO OBTAIN WARRANTY SERVICE OR PARTS

If you have a warranty claim, notify your installer promptly. If he doesn't take care of your claim, write to Comfort-Aire/Century, P.O. Box 1089, Jackson MI 49204. Enclose a report of inspection by your installer or service person. Include model number, serial number, and date of purchase.

COMMERCIAL INSTALLATION LIMITED EXPRESS WARRANTY

When installed in a commercial application, all parts are warranted to be free from defects in material and workmanship for ONE YEAR from the date of purchase by the original consumer for the original installation. The compressor only is warranted to be free from defects in material and workmanship for FIVE (5) YEARS from the date of purchase by the original consumer. All conditions/exceptions/remedy/limitation of liability as described in this warranty document apply to commercial installation coverage except for references to "residential" installation. Registration is required for units used in commercial applications. *Form No. 7954-1084Rev. 06/13*

Congratulations on your new HVAC equipment!

All Comfort-Aire/Century products are designed for long life and reliable service to help keep your home comfortable. We're so confident in the design, quality components and construction that we back your unit with one of the strongest warranties in the industry. To be eligible for the full term of this Limited Warranty coverage, register your purchase within 90 days of the purchase.

Save time and money—register online 24/7 at www.heatcontroller.com

Registration also may be completed by mail using card below.

Don't forget to read your owner's manual and ask your installer about regular maintenance procedures that will help keep your unit operating at peak efficiency.

Please follow the below steps to register your product.

- Please log onto our website www.heatcontroller.com
- Resources • Product Registration
- Complete the requested information in all caps especially the Email Address
- Press the "Continue" button at the bottom
- A copy of the registration will be sent to the email address that you entered at the top of the page for your records

KEEP THIS INFORMATION AS A RECORD OF YOUR PURCHASE	
Apply Serial Number and Model Number sticker here (from product carton). If unavailable, write serial number and model number below (can be found on unit rating plate).	
<hr/>	
<hr/>	<hr/>
Date of Purchase	Date Installation Completed
<input type="checkbox"/> Component of new HVAC system	<input type="checkbox"/> Replacement air handler only
Retain your bill of sale as proof of warranty period and ownership.	

709517A
(Replaces 7095170)
