

INSTALLATION, OPERATION & MAINTENANCE MANUAL

Multi-Zone Indoor Unit Floor Console

B-VFH09FA-1

B-VFH12FA-1

B-VFH18FA-1

ATTENTION

**When using a mini-split condensate pump
on a multi-head system,
the pump must be on a separate electrical circuit.
Do not access power from the indoor unit.**

TABLE OF CONTENTS

1.Part names and their functions.....	4
2.How to use the remote control to operate the unit	5
3. Maintenance.....	9
4.Operating guide	12
5. Precautions.....	14
6.Things to check before you call for service.....	15
7.Installation of indoor unit	16
8.Routine checks after installation	24
9.Configuration of connection pipe and additional volume of refrigerant.....	25

Thank you for selecting our product

Take the next few minutes to discover how to get comfort and economy from your new room air conditioner.

Data and diagrams in this manual may be different than actually posted on your equipment. Please refer to information on the equipment.

This appliance is not intended for use by persons (including children) with reduced physical , sensory or mental capabilities or lack of experience and knowledge,unless they have been given supervision or instruction concerning use of the appliance by a person responsible for their safety. Children should be supervised to ensure that they do not play with the appliance.

External static pressures at the appliance was tested is 0 Pa
Fuse link: T250 V; 3.15 A

1 Part Names and their Functions

Indoor Unit

⚠ Caution!

Before opening the front panel, be sure to stop the operation and turn the breaker OFF. Do not touch the metal parts on the inside of the indoor unit, as it may result in injury.

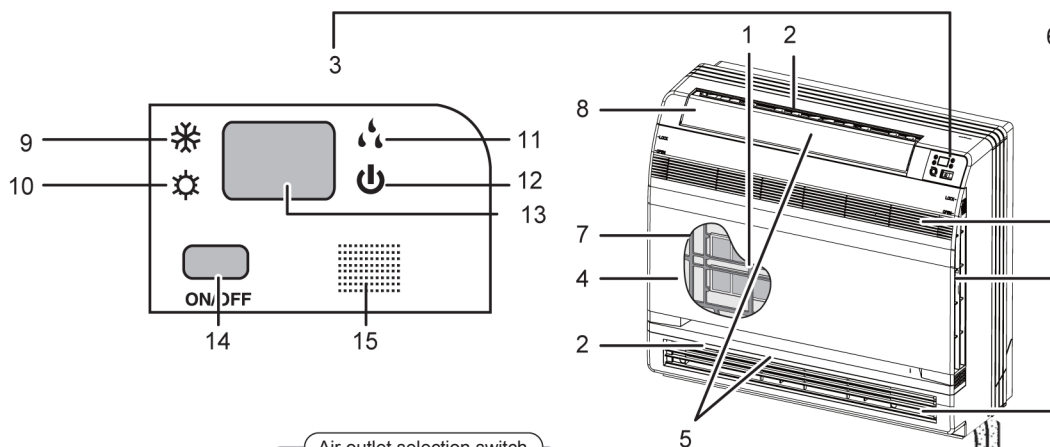

- 2. Air outlet
- 3. Display
- 4. Front panel
- 5. Louvers 9 vertical blades
 - The louvers are inside of the air outlet.
- 6. Air inlet
- 7. Air filter
- 8. Flap (horizontal blade)
- 9. Cool mode lamp
- 10. Heat mode lamp
- 11. Dry mode lamp
- 12. Run lamp
- 13. LED display
- 14. Indoor Unit ON/OFF switch:
 - Push this switch once to start operation. Push once again to stop it.
 - The operation mode refers to the following table.
- 15. Signal receiver:
 - Receives signals from the remote controller.
 - When the unit receives a signal, you will hear a short beep.

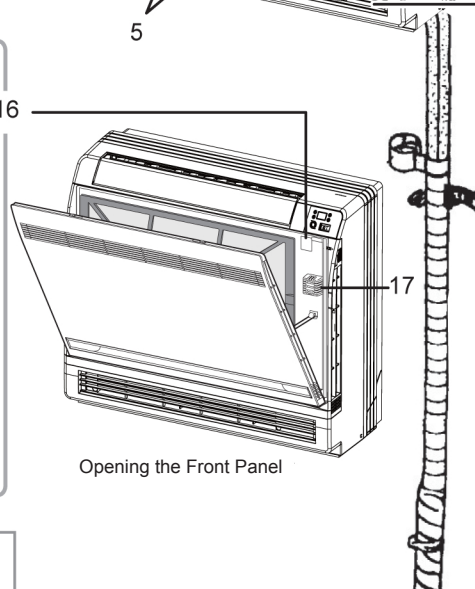
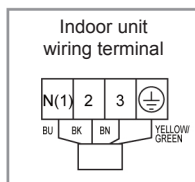
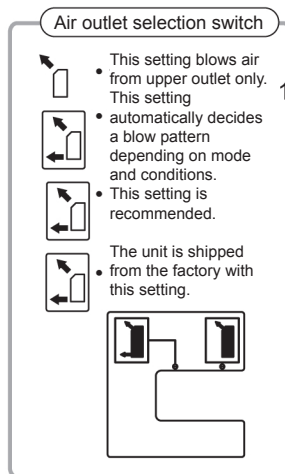

Model	Mode	Temperature Setting	Air Flow Rate
Cooling Only	Cool	77°F (25°C)	Auto
Heat Pump	Auto	77°F (25°C)	Auto

- Settings changed. . . beep
- 16. Air outlet selection switch
- 17. Room temperature sensor:
 - Senses the air temperature around the unit.

NOTE:

- ① If the power cord is damaged, it must be replaced by your service agent or a similarly qualified person in order to avoid a hazard.
- ② The appliance shall be installed in accordance with national wiring regulations.
- ③ An all-pole disconnect switch should be connected via fixed wiring.

2 How to use the remote control to operate the unit

● Remote Controller Description



- 1 ON/OFF
Press to start or stop operation
- 2 - : Press to decrease temperature setting.
- 3 + : Press to increase temperature setting.
- 4 MODE
Press to select operation mode (AUTO/COOL/DRY/FAN/HEAT).
- 5 FAN
Press to set fan speed.
- 6 SWING
Press set swing angle.
- 7 I FEEL
- 8  (This function is only applicable for some models.)
Press it to set HEALTH or AIR function.
- 9 SLEEP
- 10 TEMP
- 11 QUIET
Press to set QUIET function.
- 12 CLOCK
Press set clock.
- 13 T-ON / T-OFF
Press to set auto-off/auto-on timer.
- 14 TURBO
- 15 LIGHT
Press to turn on/off the light.
- 16 X-FAN

2 How to use the remote control to operate the unit





Remote Controller Description

- 1** ON/OFF
Press button to turn on the unit. Press button again to turn off the unit.
- 2** —: Press button to decrease set temperature. Holding down more than 2 seconds rapidly increases set temperature. In AUTO mode, set temperature is not adjustable.
- 3** +: Press button to increase set temperature. Holding down more than 2 seconds rapidly increases set temperature. In AUTO mode, set temperature is not adjustable.
- 4** MODE: Each time you press button, a mode is selected in a sequence that goes from AUTO, COOL, DRY, FAN, and HEAT *, as the following:



*Note: Only for models with heating function.



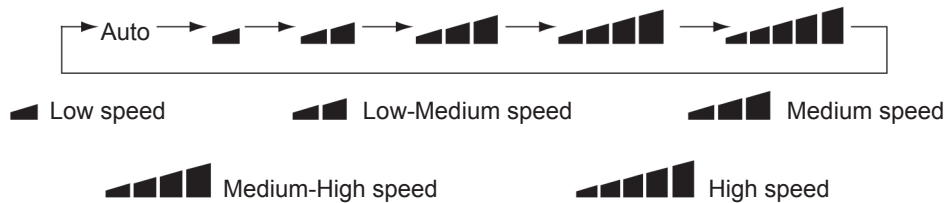

After energizing, AUTO mode is default. In AUTO mode, the set temperature will not be displayed on the LED of the indoor, and the unit will automatically select the suitable operation mode in accordance with the room temperature to make room comfortable.



- 5** FAN: This button is used for setting Fan Speed in the sequence that goes from AUTO, , , , , then back to AUTO.



- 6** SWING: Press this button to set up & down swing angle, which circularly changes as below.



This remote controller is universal. If an command ,  or  is sent out, the unit will carry out the command as 



 indicates the guide louver swings as 

- 7** I FEEL: Press this button to turn on I FEEL function. The unit automatically adjusts temperature according to the sensed indoor ambient temperature. Press this button again to cancel I FEEL function.

2 How to use the remote control to operate the unit

8 NOT AVAILABLE ON THESE UNITS.





9 SLEEP:

- Press this button, to select between Sleep 1 (), Sleep 2 (), Sleep 3 () and cancel the Sleep, circulate between these, after electrified, Sleep Cancel will default.
- Sleep 1 is Sleep mode 1, in Cool, Dehumidify modes: after running for one hour, the unit set temperature will increase 2°F (1°C) 4°F (2°C), the unit will then run at this temperature; In Heat mode: sleep status after run for one hour, the setting temperature will decrease (1°C), 2 hours, setting temperature will decrease 4°F (2°C) then the unit will run at this set temperature.
- Sleep 2 is sleep mode 2. Air conditioner will run according to the preset sleep temperature curve.
- Sleep 3 the sleep curve setting under Sleep mode by DIY:
 - (1) Under Sleep 3 mode, press and hold “Turbo” button, remote control enters into user individualizes sleep setting status, at this time, the time of remote control will display “1 hour”, the setting temperature “88” will display the corresponding temperature of last setting sleep curve and blink (The first entering will display according to the original factory);
 - (2) Adjusting “+” and “-” button will change the corresponding setting temperature, after adjusted, press “Turbo” button for confirmation.
 - (3) At this time, 1 hour increments will advance at the timer position on the remote control, (“2 hours”, “3 hours”, or “8 hours”), the set temperature display “88” will show the corresponding temperature of last setting and blink;
 - (4) Repeat the above step(2)~(3) operation, until 8 hours temperature setting finished, sleep curve setting finished, at this time, the remote control will resume the original timer display; display the corresponding temperature of last setting sleep curve and blink (The first entering will display according to the initial curve setting value of original factory); “2 hours “ or “3 hours “ or “8 hours “), the place of setting temperature “88” will display the corresponding temperature of last setting sleep curve and blink; temperature display will resume to original setting temperature.
- Sleep 3- the sleep curve setting under SLEEP mode by DIY could be inquired:
- User can choose the sleep curve setting to check the preset sleep curve, enter into user sleep setting status, but do not change the temperature, press “Turbo” button directly for confirmation. Note: In the above presetting or inquiry procedure, if within 10 s, there is no button pressed, the sleep curve setting status will automatically revert to display the original display. In the presetting or inquiry procedure, press “ON/OFF” button, “Mode” button, “TIMER” button or “SLEEP” button, the sleep curve setting or inquiry status will stop similarly.









10 TEMP:

Cycles between set temperature and indoor ambient temperature.

11 QUIET:

Press this button, the Quiet status displays under the Auto Quiet mode (display “  ” and “Auto” signal) and Quiet mode (display “  ” signal) and Quiet OFF (there is no signal of “  ” displayed), after powered on, the Quiet OFF is defaulted. Note: the Quiet function cannot be set up in Fan and Dry mode; Under the Quiet mode (Display “  ” signal), the fan speed is not available.

2 How to use the remote control to operate the unit

- 12** CLOCK:
Press CLOCK button, blinking . Within 5 seconds, pressing + or - button adjusts the present time. Holding down either button over 2 seconds increases or decreases the time by 1 minute every 0.5 second and then by 10 minutes every 0.5 second. During blinking after setting, press CLOCK button again to confirm the setting, and then  will be constantly displayed.
- 13** T-ON / T-OFF:
Press T-ON button to initiate the auto-ON timer. To cancel the auto-timer program, simply press this button again.
After pressing of this button,  disappears and "ON" blinks. 00:00 is displayed for ON time setting. Within 5 seconds, press + or - button to adjust the time value. Every press of either button changes the time setting by 1 minute. Holding down either button rapidly changes the time setting by 1 minute and then 10 minutes. Within 5 Seconds after setting, press TIMER ON button to confirm.
Press T-OFF button to initiate the auto-off timer. To cancel the auto-timer program, simply press the button again. TIMER OFF setting is the same as TIMER ON.
- 14** TURBO:
Press this button to activate / deactivate the Turbo function which enables the unit to reach the preset temperature in the shortest time. In COOL mode, the unit will blow strong cool air at super high fan speed. In HEAT mode, the unit will blow strong heating air at super high fan speed.
- 15** LIGHT:
Press LIGHT button to turn on the display's light and press this button again to turn off the display's light. If the light is turned on,  is displayed. If the light is turned off,  disappears.
- 16** X-FAN:
Pressing X-FAN button in COOL or DRY mode, the icon  is displayed and the indoor fan will continue operation for 10 minutes in order to dry the indoor unit even though you have turned off the unit. After energization, X-FAN OFF is defaulted. X-FAN is not available in AUTO, FAN or HEAT mode.
- 17** Combination of "+" and "-" buttons: lock:
Press "+" and "-" buttons simultaneously to lock or unlock the keypad. If the remote controller is locked,  is displayed. In this case, pressing any button,  blinks three times.
- 18** Combination of "MODE" and "-" buttons: switches between Fahrenheit and centigrade
At unit OFF, press "MODE" and "-" buttons simultaneously to switch between °C and °F.
- 19** Combination of "TEMP" and "CLOCK" buttons: About Energy-saving Function
Press "TEMP" and "CLOCK" simultaneously in COOL mode to start energy-saving function. Nixie tube on the remote controller displays "SE". Repeat the operation to quit the function.
- 20** Combination of "TEMP" and "CLOCK" buttons: About 46°F (8°C) Heating Function
Press "TEMP" and "CLOCK" simultaneously in HEAT mode to start 46°F (8°C) Heating Function. Nixie tube on the remote controller displays "" and a selected temperature of "46°F (8°C)". Repeat the operation to quit the function.
- 21** Back-lighting Function
The unit lights for 4s when energizing for the first time, and 3s for each additional press.

3 Maintenance

Replacement of Batteries

1. Remove the battery cover plate from the rear of the remote controller.
(As shown in the figure)
2. Take out the old batteries.
3. Insert two new AAA 1.5V dry batteries, and pay attention to the polarity.
4. Reinstall the battery cover plate.

NOTES:

- When replacing the batteries, do not use old or different types of batteries, otherwise, it may cause malfunction.
- If the remote controller will not be used for along time, please remove batteries to prevent batteries from leaking.
- The operation should be performed in its receiving range.
- The operation should be performed in its receiving range.
- Remote controller should be kept 4 ft. away from the TV set or stereo sound sets.
- If the remote controller does not operate normally, please take the batteries out and reinsert them after 30 seconds. If it still doesn't operate properly, replace the batteries.

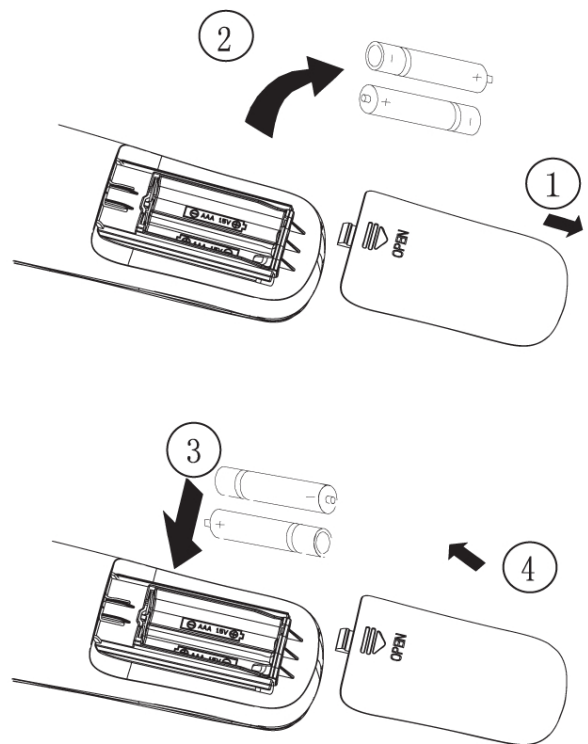

3 Maintenance

Before inspection and maintenance of the unit.
PLEASE set power switch to "OFF" to cut off the power supply.

3.1 Units

• Indoor unit, Outdoor unit and Remote controller

1. Wipe them with dry soft cloth.

• Front panel

1. Open the front panel.

Slide the two stoppers on the left and right sides inward until they click.

2. Remove the air filter. Slide the two stoppers on the left and right sides inward until they click. 2. Remove the front panel.

- Remove the string.
- Allowing the front panel to fall forward will enable you to remove it.

3. Cleaning the front panel.

- Wipe it with a soft cloth soaked in water.
- Only neutral detergent may be used.
- In case of washing the front panel with water, dry it with cloth, dry in the shade after washing.

4. Attach the front panel.

- Insert the front panel into the grooves of the unit (3 places).
- Attach the string to the right, inner-side of the front grille.
- Close the panel slowly.

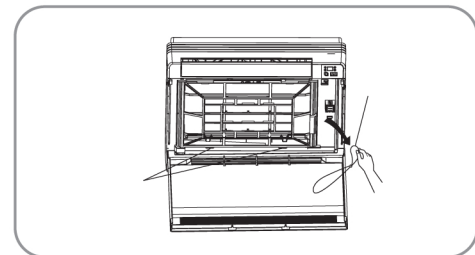
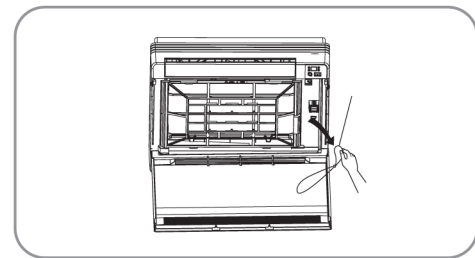
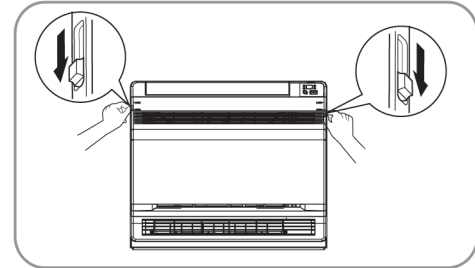

CAUTION

- Don't touch the metal parts of the indoor unit. If you touch those parts, this may cause an injury
- When removing or attaching the front panel, use a robust and stable stool and watch your steps carefully
- When removing or attaching the front panel, support the panel securely with hand to prevent it from falling.
- For cleaning, do not use hot water above 104°F (40°C), benzene, gasoline, thinner, nor other volatile oils, polishing compound, scrubbing brushes, nor other hand stuff.
- After cleaning, make sure that the front panel is securely fixed.

3.2 Filters

1. Open the front panel.

2. Remove the air filter.

- Press the claws to the right and left of the air filter down slightly, then pull upward.

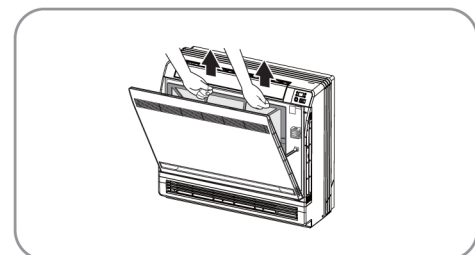

3 Maintenance

6. Wash the air filters with water or clean them with vacuum cleaner.
 - If the dust does not come off easily, wash them with neutral detergent thinned with lukewarm water, then dry them up in the shade.
 - It is recommended to clean the air filters every week.
 - Operation without air filters may result in troubles as dust will accumulate inside the indoor unit.

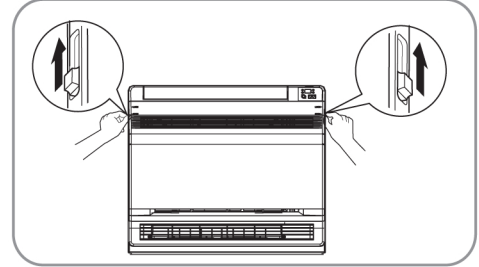

3.3 Titanium Apatite Photocatalytic Air-Purifying Filter (if available)

The Titanium Apatite Photocatalytic Air-Purifying Filter can be renewed by washing it with water once every 6 months. We recommend replacing it once every 3 years.

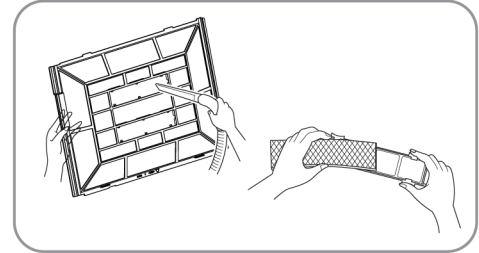

• Maintenance

1. Vacuum dusts, and soak in warm water or water for about 10 to 15 minutes if dirt is heavy.
2. Do not remove filter from frame when washing with water.
3. After washing, shake off remaining water and dry in the shade.
4. Since the material is made out of paper, do not wring out the filter when removing water from it.

• Replacement

Remove the tabs on the filter frame and replace with a new filter.

- Dispose of the old filter as flammable waste.

NOTE

- Operation with dirty filters:
 - 1) cannot deodorize the air
 - 2) cannot clean the air
 - 3) results in poor heating or cooling
 - 4) may cause odor

3.4 Before a long idle period

1. Operate the “FAN only” for several hours on a mild day to dry out the inside.
 - Press ‘MODE’ button to select “FAN” operation.
 - Press “ON/OFF” button and start operation.
2. After operation stops, turn off the breaker for the room air conditioner.
3. Clean the air filters and re-install.
4. Take out batteries from the remote controller.

NOTE

- When a multi outdoor unit is connected, make sure the heating operation is not currently being used in any other room before you use the fan operation.

4 Operating Guide

Working principle and special functions for cooling

Principle:

Air conditioner absorbs heat in the room and transmits to outdoor and discharged, so that indoor ambient temperature decreased, its cooling capacity will increase or decrease by outdoor ambient temperature.

Anti-freezing function:

If the unit is running in COOL mode and in low temperature, there will be frost formed on the heat exchanger, when indoor heat exchanger temperature decreased below 32°F (0°C), the indoor unit microcomputer will stop compressor and protect the unit.

Working principle and special functions for heating

Principle:

- Air conditioner absorbs heat from outdoor and transmits to indoor, to increase room temperature. This is the heat pump heating principle, its heating capacity will be reduced due to outdoor temperature decrease.
- If outdoor temperature becomes very low, please use other heating sources.

Defrost:

- When outdoor temperature is low but high humidity, after a long while running, frost will form on outdoor unit, that will effect the heating effect, at this time, the auto defrosting function will act, and the heat will stop for 8-10 mins.
 - During the auto defrosting, the fan motors of indoor unit and outdoor unit will stop.
 - During the defrosting, the indoor indicator flashes(or displays "H1"), the outdoor unit may emit vapor, This is due to the defrosting, it is a normal condition.
 - After defrosting is finished, the heating will resume.
-

Anti-cool wind function:

In certain situations the indoor fan will be delayed due to cool indoor coil temperatures:

1. Heat operation just starting up.
2. After Auto defrost operation is finished.
3. Heating under low temperature.

4 Operating Guide

- The temperature should not be set lower than what you need. This would result to increased energy cost.

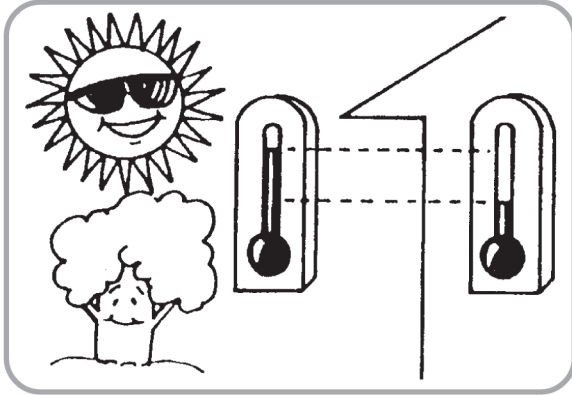

- To distribute cool air through out the room, adjust air flow direction as shown by the arrows (see picture) do diffuse cool air.

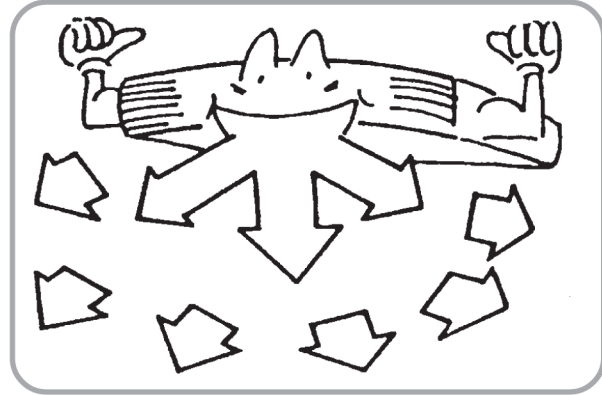

- Clean the air filter every week during heavy use for higher efficiency.

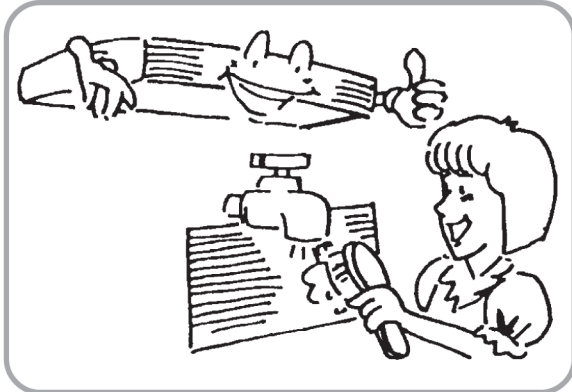

- Close windows and doors while operating the unit to prevent leakage of cooled air to save energy.

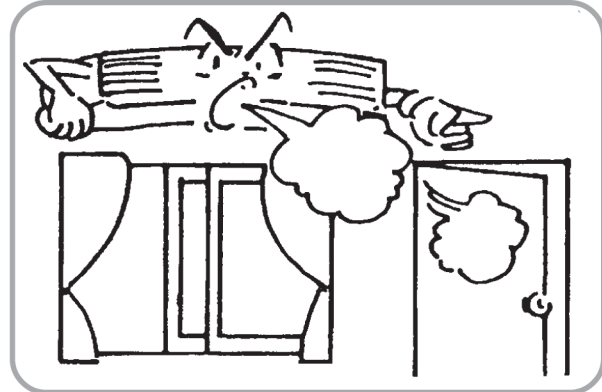

- Draw close curtains or close glass window when cooling to prevent heat load from sunlight.



- In case of insufficient ventilation, open the window to ventilate the room air once in a while but not too long since cooled air will be lost.

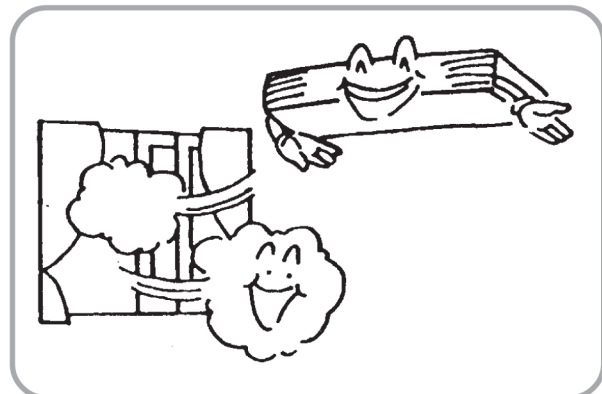

5 Precautions

■ Check electrical system (voltage and frequency). Use the proper power supply indicated on the unit to operate the air conditioner and only uses with specified capacity. Do not use pieces of wire instead of fuse.



■ Turn off the air conditioner if, while running, electricity interference occurs. If the unit is not to be used for a long time, cut off the power disconnect switch.

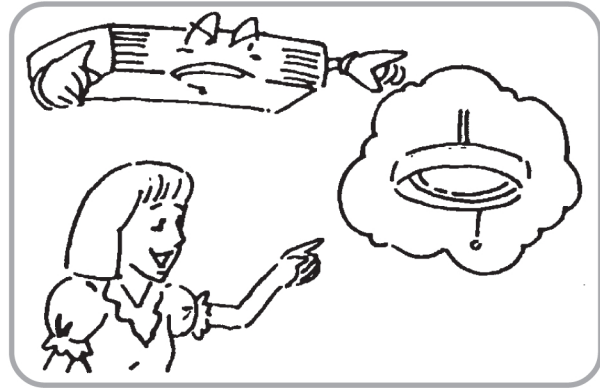

■ Do not insert objects into the air inlet or outlet when the air conditioner is running as it may cause damage or personal injury. Also pay special attention when children are around.

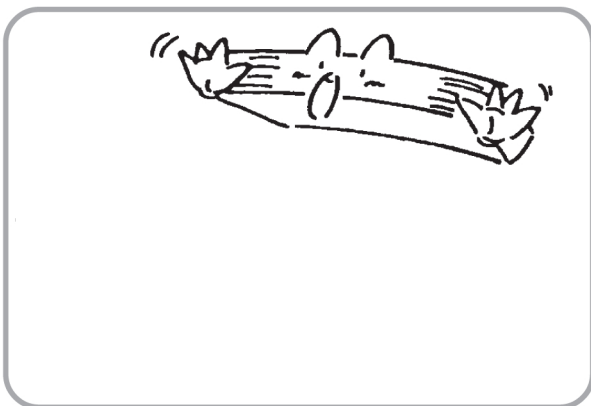

■ Do not locate any obstacle against the air flow direction of indoor and outdoor unit. Inefficient performance or malfunction may result.

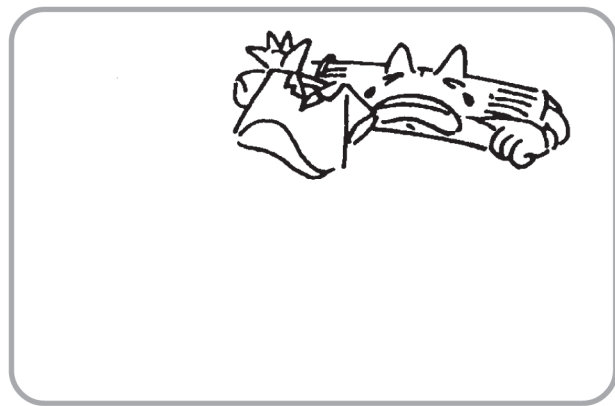

■ Do not channel the air flow directly at people, especially infant, aged persons, anyone is ill.



■ Do not locate a heater or any other heat source close to the unit. The heat may deform plastic parts.



6 Things to check before you call for service

Check the following before contacting the service man.

PROBLEM	CAUSES
No operation.	<ul style="list-style-type: none">• Check if electrical wire is damaged & check if breaker switch is still on.• Check if the power supply is in order.• Check if the timer switch is on or not.
The air conditioner runs but does not cool enough.	<ul style="list-style-type: none">• Check if the preset temperature is too high.• Check if the sunlight shines directly into the room.• Check if the door and window are opened.• Check if there is anything obstructing the air discharge.• Check if the exhaust fan still operates.• Check if the air filter is dirty or clogged.
Vapor or mist coming out of the unit while running.	<ul style="list-style-type: none">• Hot air in the room mixes with cool air. This causes a mist to discharge.
Inoperative remote control.	<ul style="list-style-type: none">• Check batteries.• Check if the batteries are inserted in correct directions.

7 Installation of indoor unit

Selection of installation location

- An area where cool air can be distributed throughout the room.
- Such a place where condensation water is easily drained out.
- A mounting surface that can handle the weight of indoor unit.
- An area that has easy access for maintenance.
- Do not install in a laundry.

There are 2 styles of installation

• CEILING TYPE

• FLOOR TYPE

Each type is similar to there other as follows;

Indoor Unit

The indoor unit should be sited in a place where:

- 1) the restrictions on installation specified in the indoor unit installation drawings are met.
- 2) both air intake and exhaust have clear paths.
- 3) the unit is not in the path of direct sunlight.
- 4) the unit is away from any source of heat or steam.
- 5) there is no source of machine oil vapor (this may shorten indoor unit life).
- 6) cool (warm) air is circulated throughout the room.
- 7) the unit is away from electronic ignition type fluorescent lamps inverter or rapid start type) as they may shorten the remote controller range.
- 8) the unit is at least 4 ft. away from any television or radio set (unit may cause interference with the picture or sound).

Cautions for installation where air conditioner trouble is liable to occur

- Where there is too much of oil area.
- Where it is acid base area.
- Where there is irregular electrical supply.

Indoor Unit Installation Drawings

The indoor unit may be mounted in any of the three styles shown here.

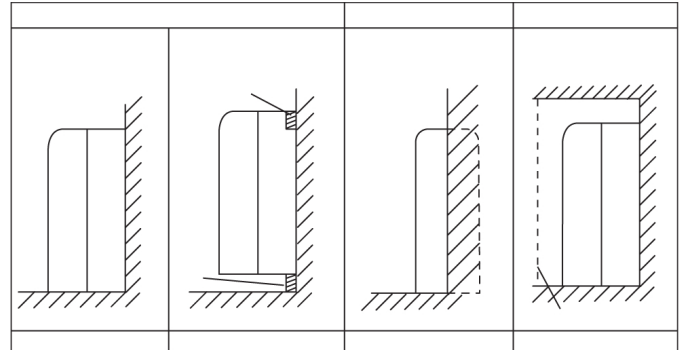

Location for securing the installation panel.

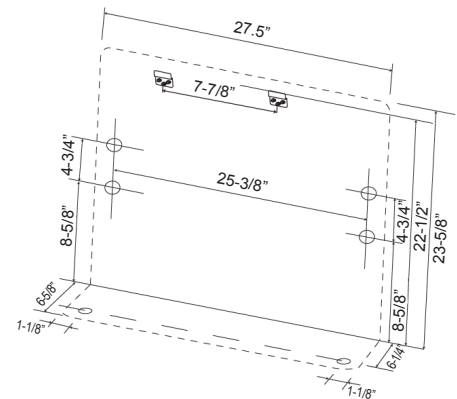

Schematic drawing of hooks:

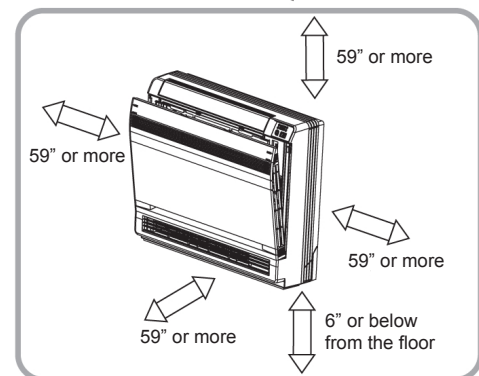
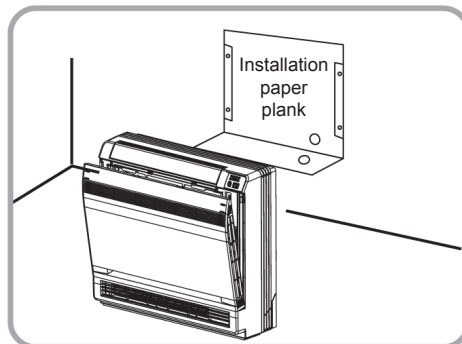
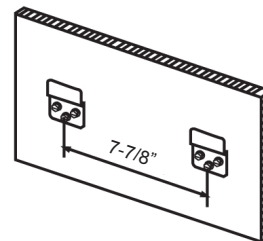

7 Installation of indoor unit

Refrigerant Piping

- 1) Drill a hole (2" in diameter) in the spot indicated by the  symbol in the illustration as below.
- 2) The location of the hole is different depending on which side the pipe is taken out.
- 3) For piping, see **Connecting the refrigerant pipe**, under Indoor Unit Installation (1).
- 4) Allow space around the pipe for a easier indoor unit pipe connection.

(Unit: inches)

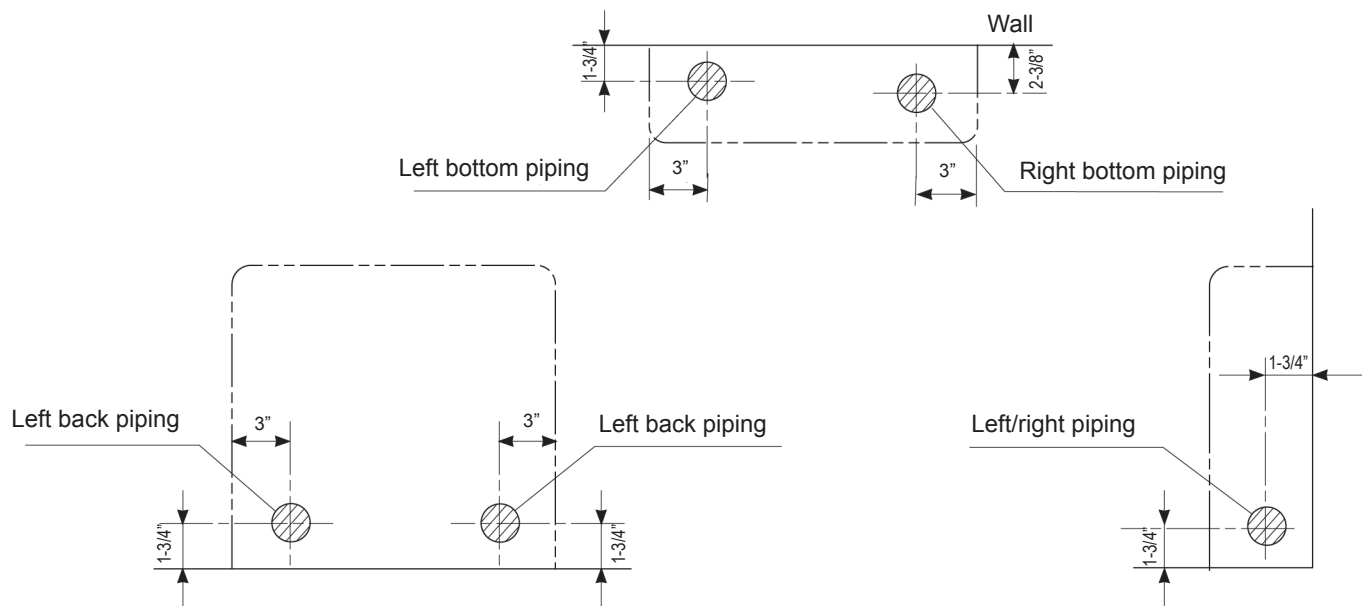

Caution!

Min. allowable length

- The suggested shortest pipe length is 10 ft. in order to avoid noise from the outdoor unit and vibration. (Mechanical noise and vibration may occur depending on how the unit is installed and the environment in which it is used.)
- See the installation manual for the outdoor unit for the maximum pipe length.

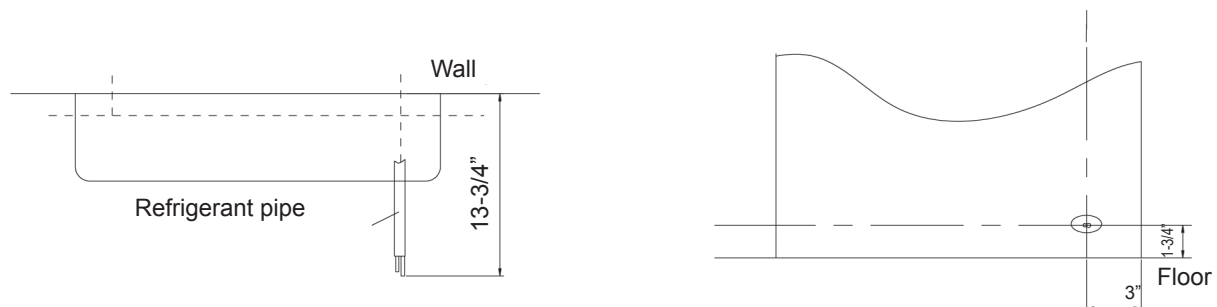

7 Installation of indoor unit

Boring a wall hole and installing wall embedded pipe

- For walls containing metal frame or metal board, be sure to use a wall embedded pipe and wall cover in the feed-through hole to prevent water leakage.
- Be sure to caulk the gaps around the pipes with caulking material to prevent water leakage.

10 Bore a feed-through hole of 2-1/8" in the wall so it has a down slope toward the outside.

- 2) Insert a wall pipe into the hole.
- 3) Insert a wall cover into wall pipe.
- 4) After completing refrigerant piping, wiring, and drain piping, caulk pipe hole gap with putty.

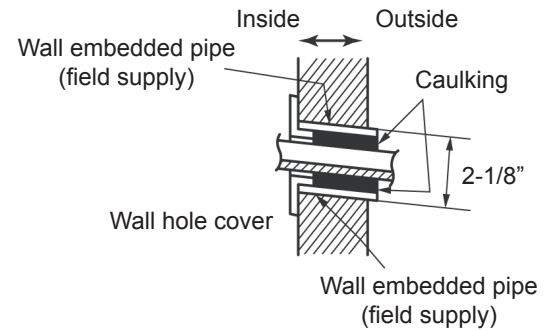

Drain piping

- 1) Use commercial rigid polyvinyl chloride pipe (general VP 20 pipe, outer diameter 1", inner diameter 3/4" for the drain pipe.
- 2) The drain hose is supplied with the indoor unit. Prepare the drain per the pipe picture below.
- 3) The drain pipe should be inclined downward so that water will flow smoothly without any accumulation. (Should not be trapped).
- 4) Insert the drain hose to this depth so it won't be pulled out of the drain pipe.
- 5) Insulate the indoor drain pipe with 3/8" or more of insulation material to prevent condensation.
- 6) Remove the air filters and pour some water into the drain pan to check that water flows smoothly.

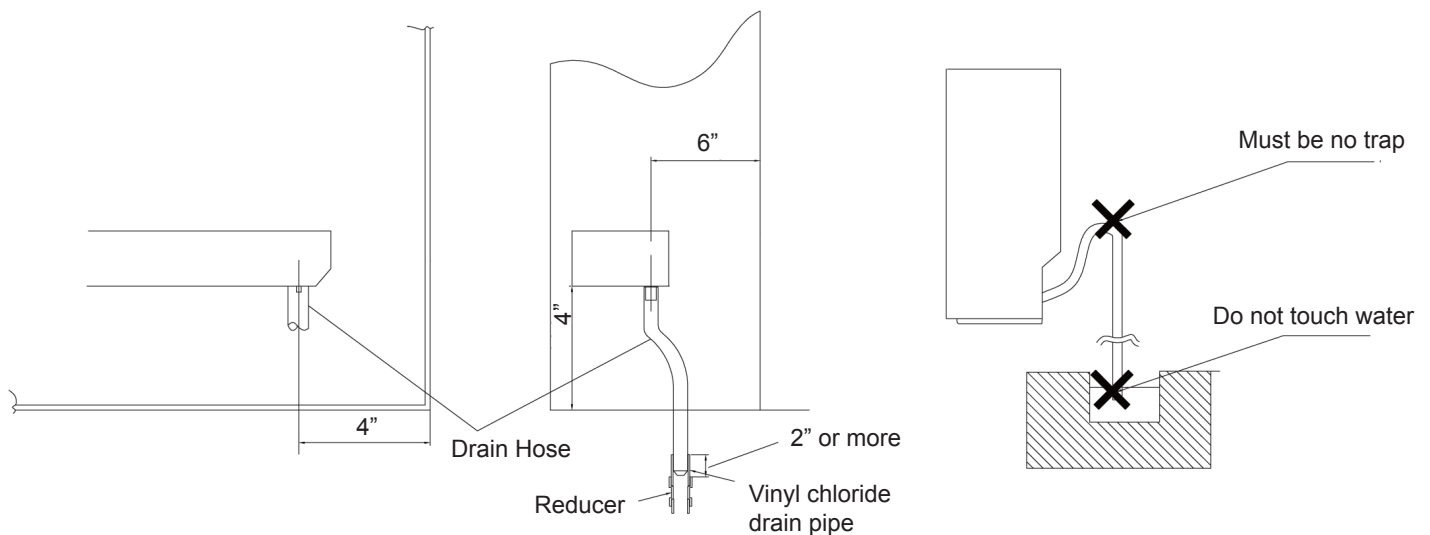

7 Installation of indoor unit

Installing indoor unit

1. Preparation

- Open the front panel, remove the 4 screws and dis-mount the front grille while pulling it forward.
- Follow the arrows to disengage the clasps on the front case to remove it.
- Follow the procedure below when removing the slit portions.

For Moldings

- Remove the pillars. (Remove the slit portions on the bottom frame using nippers.)

For Side Piping

- 1) Remove the 7 screws.
- 2) Remove the upper casing (2 tabs).
- 3) Remove the left and right casings (2 tabs on each side).
- 4) Remove the slit portions on the bottom frame and casings using nippers.
- 5) Return by following the steps in reverse order(3>2>1).

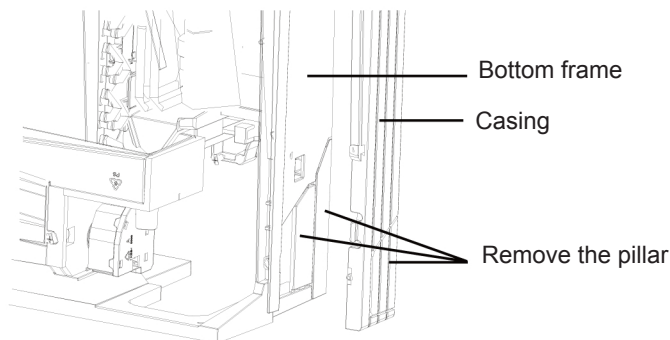
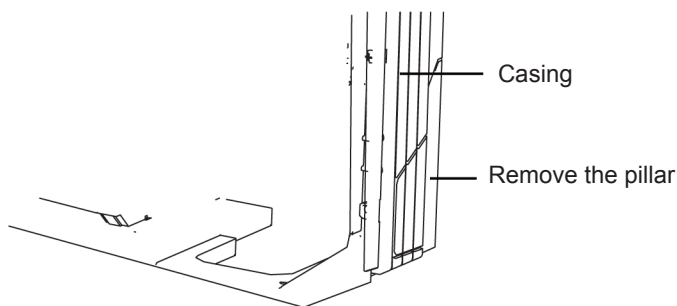
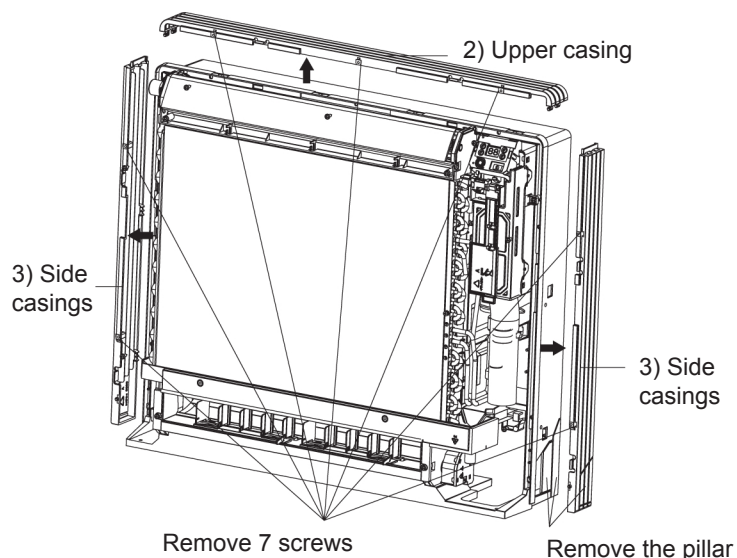
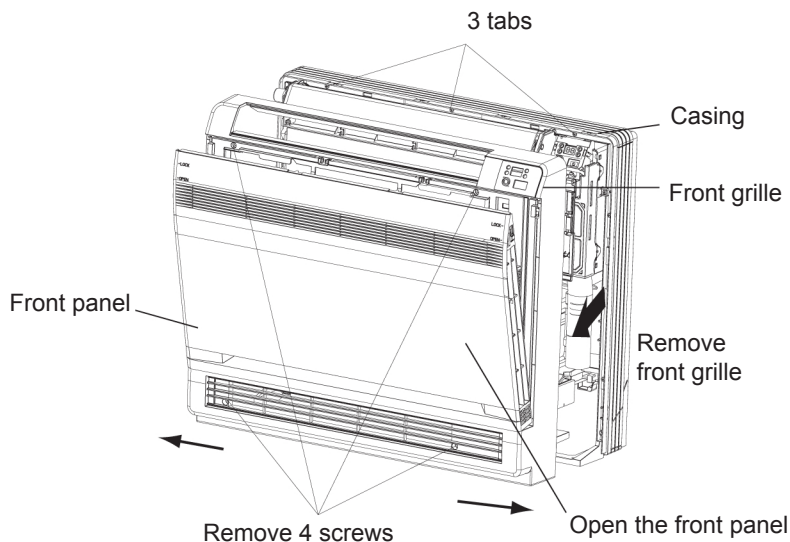

2. Installation

- Secure using 6 screws for floor installations. (Do not forget to secure to the rear wall.)
- For wall installations, secure the mounting plate using 5 screws and the indoor unit using 4 screws.

7 Installation of indoor unit

The mounting plate should be installed on a wall which can support the weight of the indoor unit.

- 1) Temporarily secure the mounting plate to the wall, make sure that the panel is completely level, and mark the boring points on the wall.
- 2) Secure the mounting plate to the wall with screws.

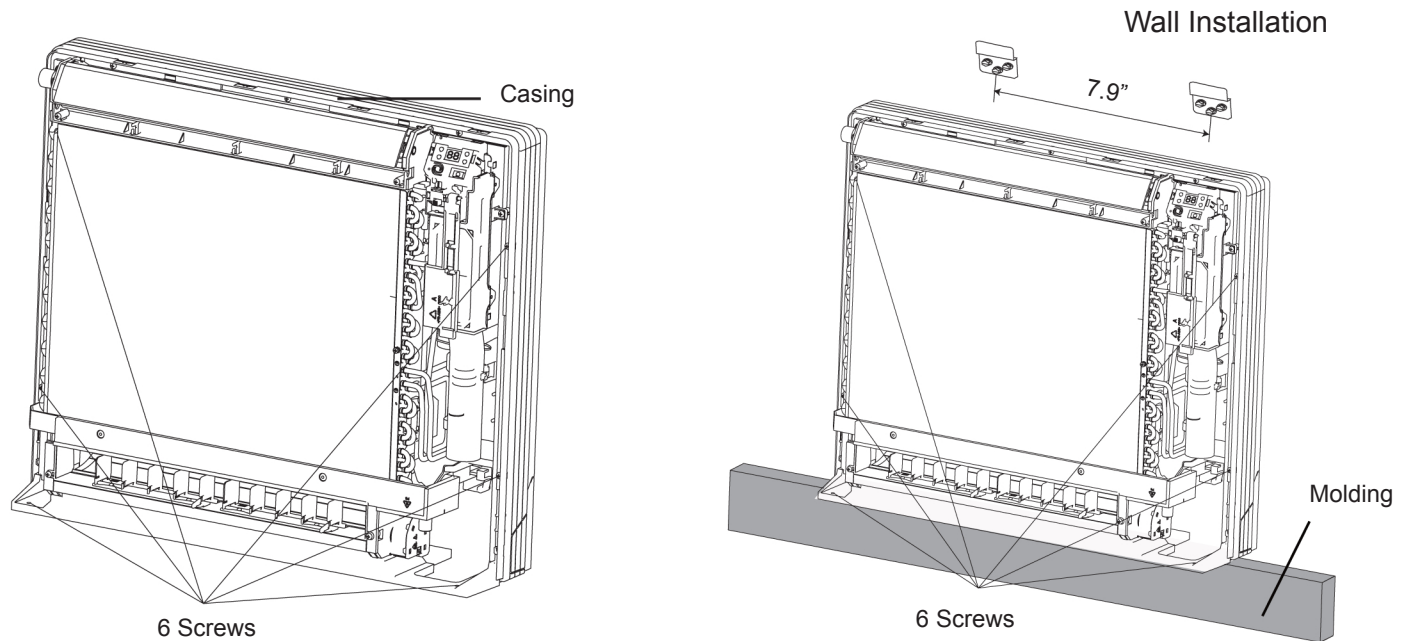

- 3) Once refrigerant piping and drain piping connections are complete, fill in the gap of the through hole with putty. A gap can lead to condensation on the refrigerant pipe, and drain pipe, and the entry of insects into the pipes.

- 4) Attach the front panel and front grille in their original positions once all connections are complete.

Flaring the pipe end

- 1) Cut the pipe end with a pipe cutter.
- 2) Remove burrs with the cut surface facing downward so that the chips do not enter the pipe.
- 3) Fit the flare nut on the pipe.
- 4) Flare the pipe.
- 5) Check that the flaring is properly made.

Warning!

- 1) DO not use mineral oil on flared part.
- 2) Prevent mineral oil from getting into the system as this would reduce the lifetime of the units.
- 3) Never use piping which had been used for previous installations. Only use parts which are delivered with the unit.
- 4) Never install a drier to this R410A unit.
- 5) The drying material may dissolve and damage the system.
- 6) Incomplete flaring may cause refrigerant gas leakage

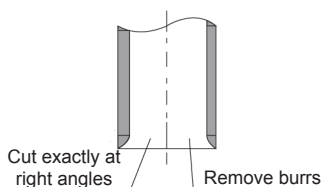

Flaring

Set exactly at the position shown below

	Flare tool for R410A		Conventional flare tool	
	Clutch-type	Clutch-type (Rigid-type)	Wing-nuttype (Imperial-type)	
A	0-0.5mm	1.0-1.5mm	1.5-2.0mm	

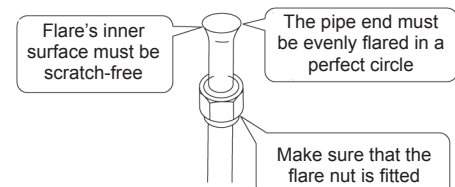

7 Installation of indoor unit

Caution on piping handling

- 1) Protect the open end of the pipe against dust and moisture.
- 2) All pipe bends should be as gentle as possible. Use a pipe bender for bending.
(Bending radius should be 1-1/4" to 1-1/2" or larger.)

Selection of copper and heat insulation materials

- When using commercial copper pipes and fittings, observe the following:
 - Refrigerant gas pipe's surface temperature reaches 230°F (110°C) max.
 - Choose heat insulation materials that will withstand this temperature.
- 1) Be sure to insulate both the gas and liquid piping.
 - 2) Use separate thermal insulation pipes for gas and liquid refrigerant pipes.

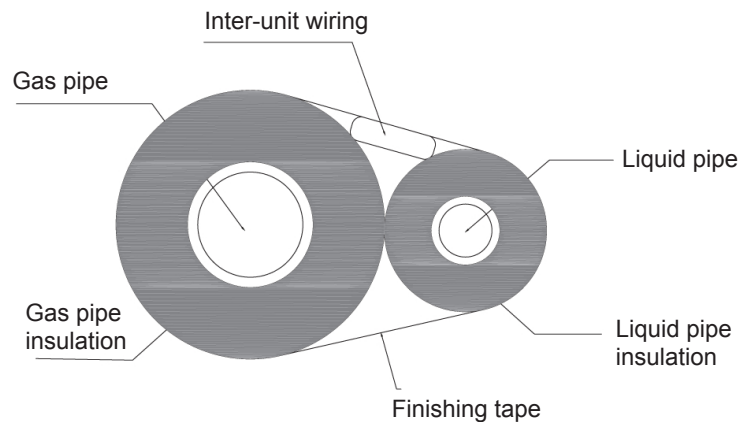
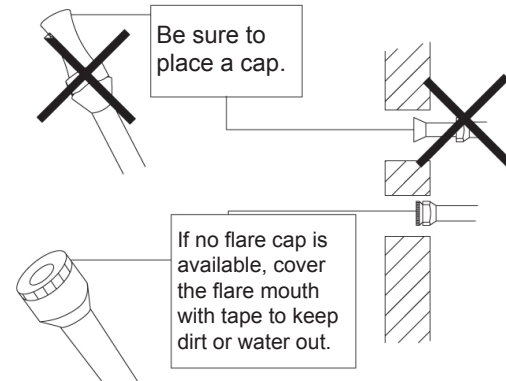

7 Installation of indoor unit

Checking for gas leakage

- 1) Check for leakage of gas after evacuation and nitrogen charge.
- 2) See the sections on air purges and gas leak checks in the installation manual for the outdoor unit.

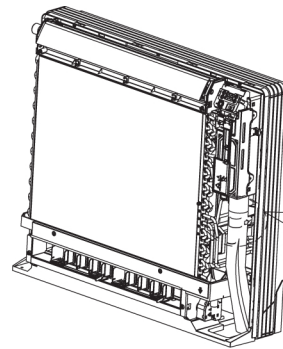

- Check for leakage here
- Apply soapy water and check carefully for leaking gas.
 - Wipe soapy water off after the check is complete.

Attaching the connection pipe

- Attach the pipe after checking for gas leakage, described above.

- 1) Cut the insulated portion of the on-site piping, matching it up with the connecting portion.
- 2) Secure the slit on the refrigerant piping side with the butt joint on the auxiliary piping using the tape, making sure there are no gaps.
- (3) Wrap the slit and butt joint with the included insulation sheet, making sure there are no gaps.

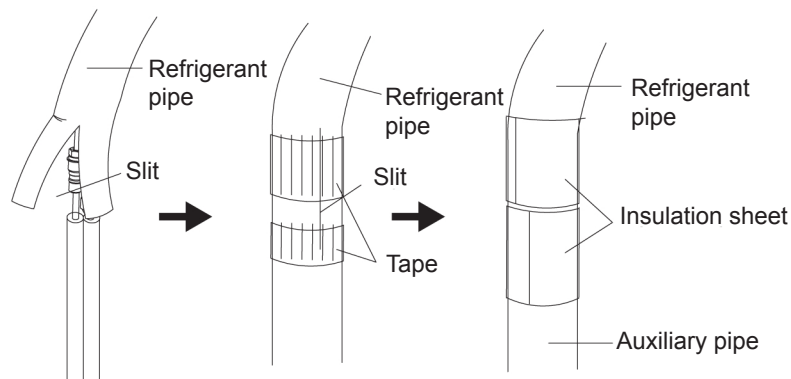

⚠ Caution!

- 1) Insulate the joint of the pipes securely.
Incomplete insulation may lead to water leakage.
 - 2) Push the pipe inside so it does not place undue force on the front grille.
-

Connecting the drain hose

Insert the supplied C drain hose into the socket of the drain pan.

Fully insert the drain hose until it adheres to a seat of the socket.

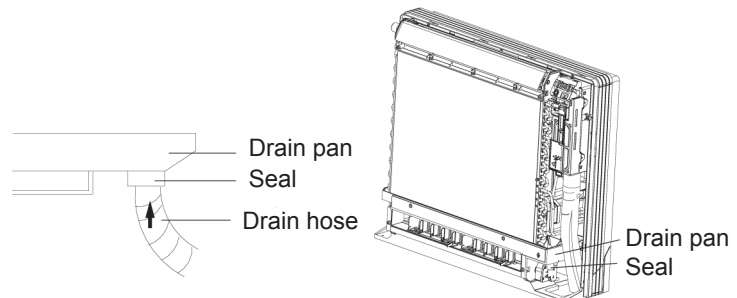

7 Installation of indoor unit

- Open the sensor securing plate, remove the front metal plate cover, and connect the branch wiring to the terminal block.
 - 1) Strip wire ends (5/8”).
 - 2) Match wire colors with terminal numbers on indoor and outdoor unit’s terminal blocks and firmly screw wires to the corresponding terminals.
 - 3) Connect the earth wires to the corresponding terminals.
 - 4) Pull wires to make sure that they are securely attached, then secure wires with wire retainer.

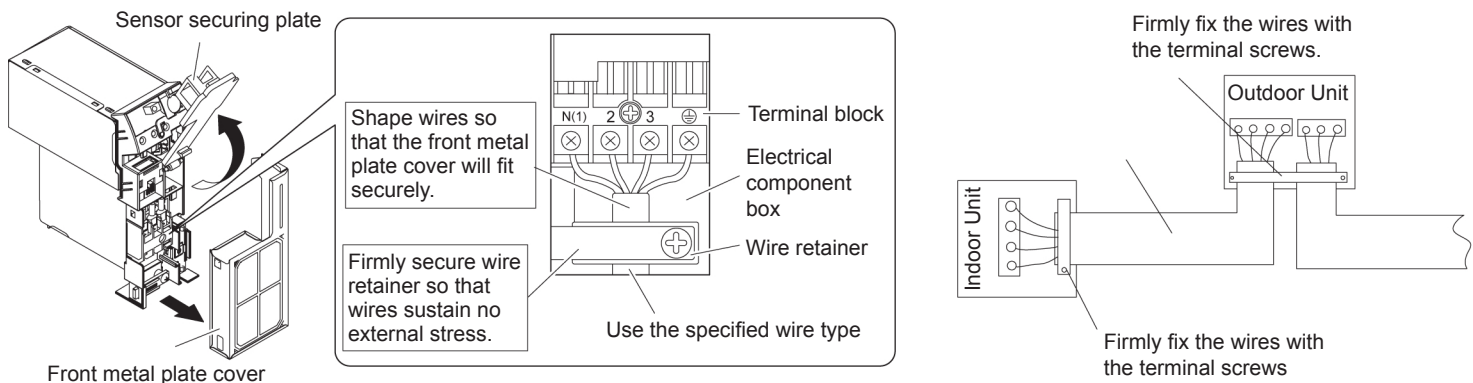

Caution!

- 1) Do not use taped wires, extension cords, or starburst connections, as they may cause overheating, electrical shock, or fire.
 - 2) Do not use locally purchased electrical parts inside the product. (Do not branch the power for the drain pump, etc, from the terminal block.) Doing so may cause electric shock or fire.)
-

8 Routine checks after installation

Check after installation

Items to be checked	Items to be checked	Situation
Has it been mounted firmly?	The unit may drop,shake or emit noise.	
Have you done the refrigerant leakage test?	It may cause insufficient refrigerating capacity.	
Is line insulation sufficient?	It may cause condensation and dripping .	
Does the unit drain well?	It may cause condensation and dripping.	
Is the voltage in accordance with the rated voltage marked on the nameplate?	It may cause electric malfunction or damage parts.	
Is the electrical wiring and piping connection installed correctly and securely?	It may cause electric malfunction or damage parts.	
Has the unit been connected to a secure earth connection?	It may cause electrical leakage, injury or death.	
Is the power cord as specified?	It may cause electric malfunction or damage the part.	
Has the inlet and outlet been insulation?	It may cause insufficient refrigerating capacity.	
Has the length of connection pipes and the refrigerant charge been recorded?	The refrigerating capacity will not be accurate.	

9 Configuration of connection pipe and additional volume of refrigerant

1. Standard length of connection pipe 16.5 ft.
2. Min. length of connection pipe 10 ft.
3. Max length of connection pipe.

Sheet 1. Max length of connection pipe Unit: ft. (m)

Capacity	Max length of connection pipe
5000 Btu/h (1465 W)	50 ft.
7000 Btu/h (2051 W)	50 ft.
9000 Btu/h (2637 W)	50 ft.
12000 Btu/h (3516 W)	65 ft.
1800 Btu/h (5274 W)	82 ft.

Capacity	Max length of connection pipe
24000 Btu/h (7032 W)	82 ft.
28000 Btu/h (8204 W)	98 ft.
36000 Btu/h (10548 W)	98 ft.
42000 Btu/h (12306 W)	98 ft.
48000 Btu/h (14064 W)	98 ft.

4. The calculation method of additional refrigerant oil and refrigerant charging amount after prolonging connection pipe. After the length of connection pipe is extended past 33 ft. (10 m) over standard length, you should add 1-3/4 oz. (5 ml) of refrigerant oil for each additional 16.5 ft of connection pipe. The calculation method of additional refrigerant charging amount (on the basis of liquid pipe):
 - (1) Additional refrigerant charging amount= prolonged length of liquid pipe × additional refrigerant charging amount per meter.
 - (2) When the length of connection pipe is above 16.5 ft, add refrigerant according to the prolonged length of liquid pipe. The additional refrigerant charging amount per ft. is different according to the diameter of liquid pipe. See Sheet 2.

Sheet 2. Additional refrigerant charging amount for R410A.

Liquid Line Size

1/4" - .02 oz/ft.

3/8" - .04 oz/ft.

1/2" - .05 oz/ft.

This page is left intentionally blank.

This page is left intentionally blank.

This page is left intentionally blank.

Due to ongoing product improvements, specifications and dimensions are subject to change and correction without notice or incurring obligations. Determining the application and suitability for use of any product is the responsibility of the installer. Additionally, the installer is responsible for verifying dimensional data on the actual product prior to beginning any installation preparations.

Incentive and rebate programs have precise requirements as to product performance and certification. All products meet applicable regulations in effect on date of manufacture; however, certifications are not necessarily granted for the life of a product. Therefore, it is the responsibility of the applicant to determine whether a specific model qualifies for these incentive/rebate programs.

1900 Wellworth Ave., Jackson MI 49203 • Ph. 517-787-2100 • www.heatcontroller.com