Comfort-Aire®

Century®

SERVICE MANUAL

VHP SERIES

Multi-Zone Mini-Splits

Model

VHP183A-1

VHP284A-1

VHP365A-1

VHP486A-1

VHP556A-1



Table of Contents

1. Safety Precautions

1. Precautions
2. Information servicing(For flammable materials)

2. Specifications

1. Model Reference
2. Pipe Length and Drop Height
3. Indoor units combination
4. Refrigeration Cycle Diagrams
5. Electrical Wiring Diagrams

3. Electronic Functions

- 1 Abbreviation
- 2 Main Protection

4. Outdoor Unit Disassembly

1. Outdoor Unit Table
2. Dimension
3. Outdoor Unit Disassembly

5. Troubleshooting

1. Safety Caution
2. General Troubleshooting
3. Outdoor Unit Point Check Function
4. Quick Maintenance by Error Code
5. Troubleshooting by Error Code
6. Check Procedures

Appendix

- i) Temperature Sensor Resistance Value Table for TP (°C – K)
 - ii) Other Temperature Sensor Resistance Value Table (°C – K)
 - iii) Pressure On Service Port
- 

Safety Precautions

Contents

1.	Precautions.....	2
2.	Information servicing(For flammable materials).....	4

1. Precautions

To prevent personal injury, or property or unit damage, adhere to all precautionary measures and instructions outlined in this manual. Before servicing a unit, refer to this service manual and its relevant sections.

Failure to adhere to all precautionary measures listed in this section may result in personal injury, damage to the unit or to property, or in extreme cases, death.

 **WARNING** indicates a potentially hazardous situation which if not avoided could result in serious personal injury, or death.

 **CAUTION** indicates a potentially hazardous situation which if not avoided could result in minor or moderate personal injury, or unit damage.

1.1 In case of Accidents or Emergency

WARNING

- If a gas leak is suspected, immediately turn off the gas and ventilate the area if a gas leak is suspected before turning the unit on.
- If strange sounds or smoke is detected from the unit, turn the breaker off and disconnect the power supply cable.
- If the unit comes into contact with liquid, contact an authorized service center.
- If liquid from the batteries makes contact with skin or clothing, immediately rinse or wash the area well with clean water.
- Do not insert hands or other objects into the air inlet or outlet while the unit is plugged in.
- Do not operate the unit with wet hands.
- Do not use a remote controller that has previously been exposed to battery damage or battery leakage.

CAUTION

- Clean and ventilate the unit at regular intervals when operating it near a stove or near similar devices.
- Do not use the unit during severe weather conditions. If possible, remove the product from the window before such occurrences.

1.2 Pre-Installation and Installation

WARNING

- Use this unit only on a dedicated circuit.
- Damage to the installation area could cause the unit to fall, potentially resulting in personal injury, property damage, or product failure.
- Only qualified personnel should disassemble, install, remove, or repair the unit.
- Only a qualified electrician should perform electrical work. For more information, contact your dealer, seller, or an authorized service center.

CAUTION

- While unpacking be careful of sharp edges around the unit as well as the edges of the fins on the condenser and evaporator.

1.3 Operation and Maintenance

WARNING

- Do not use defective or under-rated circuit breakers.
- Ensure the unit is properly grounded and that a dedicated circuit and breaker are installed.
- Do not modify or extend the power cable. Ensure the power cable is secure and not damaged during operation.
- Do not unplug the power supply plug during operation.
- Do not store or use flammable materials near the unit.
- Do not open the inlet grill of the unit during operation.
- Do not touch the electrostatic filter if the unit is equipped with one.
- Do not block the inlet or outlet of air flow to the unit.
- Do not use harsh detergents, solvents, or similar items to clean the unit. Use a soft cloth for cleaning.
- Do not touch the metal parts of the unit when removing the air filter as they are very sharp.
- Do not step on or place anything on the unit or outdoor units.
- Do not drink water drained from the unit
- Avoid direct skin contact with water drained from the unit.
- Use a firm stool or step ladder according to manufacturer procedures when cleaning or maintaining the unit.

CAUTION

- Do not install or operate the unit for an extended period of time in areas of high humidity or in an environment directly exposing it to sea wind or salt spray.
- Do not install the unit on a defective or damaged installation stand, or in an unsecure location.
- Ensure the unit is installed at a level position
- Do not install the unit where noise or air discharge created by the outdoor unit will negatively impact the environment or nearby residences.
- Do not expose skin directly to the air discharged by the unit for prolonged periods of time.
- Ensure the unit do not operate in areas water or other liquids.
- Ensure the drain hose is installed correctly to ensure proper water drainage.
- When lifting or transporting the unit, it is recommended that two or more people are used for this task.
- When the unit is not to be used for an extended time, disconnect the power supply or turn off the breaker.

WARNING For Using Flammable Refrigerant

1. Installation (where refrigerant pipes are allowed)
 - Any person who is involved with working on or breaking into a refrigerant circuit should hold a current valid certificate from an industry-accredited assessment authority, which authorises their competence to handle refrigerants safely in accordance with an industry recognised assessment specification.
 - Maintenance and repair requiring the assistance of other skilled personnel shall be carried out under the supervision of the person competent in the use of flammable refrigerants.
 - That the installation of pipe-work shall be kept to a minimum.
 - That pipe-work shall be protected from physical damage.
 - Where refrigerant pipes shall be compliance with national gas regulations.
 - That mechanical connections shall be accessible for maintenance purposes.
 - Be more careful that foreign matter (oil, water, etc) does not enter the piping.
 - Also, when storing the piping, securely seal the opening by pinching, taping, etc.
 - Appliance shall be stored in a well ventilated area where the room size corresponds to the room area as specified for operation.
 - Appliance shall be stored in a well ventilated area where the room size corresponds to the room area as specified for operation.
 - Joints shall be tested with detection equipment with a capability of 5 g/year of refrigerant or better, with the equipment in standstill and under operation or under a pressure of at least these standstill or operation conditions after installation. Detachable joints shall NOT be used in the indoor side of the unit (brazed, welded joint could be used).
 - In cases that require mechanical ventilation, ventilation openings shall be kept clear of obstruction.
2. When a FLAMMABLE REFRIGERANT is used, the requirements for installation space of appliance and /or ventilation requirements are determined according to
 - the mass charge amount (M) used in the appliance,
 - the installation location,
 - the type of ventilation of the location or of the appliance.
 - piping material, pipe routing, and installation shall include protection from physical damage in operation and service, and be in compliance with national and local codes and standards, such as ASHRAE 15, IAPMO Uniform Mechanical Code, ICC International Mechanical Code, or CSA B52. All field joints shall be accessible for inspection prior to being covered or enclosed.
 - that protection devices, piping, and fittings shall be protected as far as possible against adverse environmental effects, for example, the danger of water collecting and freezing in relief pipes or the accumulation of dirt and debris;
 - that piping in refrigeration systems shall be so designed and installed to minimize the likelihood of hydraulic shock damaging the system;
 - that steel pipes and components shall be protected against corrosion with a rustproof coating before applying any insulation;
 - that precautions shall be taken to avoid excessive vibration or pulsation;
 - the minimum floor area of the room shall be mentioned in the form of a table or a single figure without reference to a formula;
 - after completion of field piping for split systems, the field pipe-work shall be pressure tested with an inert gas and then vacuum

tested prior to refrigerant charging, according to the following requirements:

- a. The minimum test pressure for the low side of the system shall be the low side design pressure and the minimum test pressure for the high side of the system shall be the high side design pressure, unless the high side of the system can not be isolated from the low side of the system in which case the entire system shall be pressure tested to the low side design pressure.
- b. The test pressure after removal of pressure source shall be maintained for at least 1 h with no decrease of pressure indicated by the test gauge, with test gauge resolution not exceeding 5% of the test pressure.
- c. During the evacuation test, after achieving a vacuum level specified in the manual or less, the refrigeration system shall be isolated from the vacuum pump and the pressure shall not rise above 1500 microns within 10 min. The vacuum pressure level shall be specified in the manual, and shall be the lesser of 500 microns or the value required for compliance with national and local codes and standards, which may vary between residential, commercial, and industrial buildings.
 - field-made refrigerant joints indoors shall be tightness tested according to the following requirements: The test method shall have a sensitivity of 5 grams per year of refrigerant or better under a pressure of at least 0,25 times the maximum allowable pressure. No leak shall be detected.
 - Any servicing shall be performed only as recommended by the manufacturer.

3. Qualification of workers

Any maintenance, service and repair operations must be required qualification of the working personnel. Every working procedure that affects safety means shall only be carried out by competent persons that joined the training and achieved competence should be documented by a certificate. The training of these procedures is carried out by national training organizations or manufacturers that are accredited to teach the relevant national competency standards that may be set in legislation. All training shall follow the ANNEX HH requirements of UL 60335-2-40 4th Edition.

Examples for such working procedures are:

- breaking into the refrigerating circuit;
- opening of sealed components;
- opening of ventilated enclosures.

2. Information servicing(For flammable materials)

2.1 Checks to the area

- Prior to beginning work on systems containing flammable refrigerants, safety checks are necessary to ensure that the risk of ignition is minimized. For repair to the refrigerating system, the following precautions shall be complied with prior to conducting work on the system.

2.2 Work procedure

- Work shall be undertaken under a controlled procedure so as to minimise the risk of a flammable gas or vapour being present while the work is being performed.

2.3 General work area

- All maintenance staff and others working in the local area shall be instructed on the nature of work being carried out. Work in confined spaces shall be avoided.

2.4 Checking for presence of refrigerant

- The area shall be checked with an appropriate refrigerant detector prior to and during work, to ensure the technician is aware of potentially flammable atmospheres.
- Ensure that the leak detection equipment being used is suitable for use with flammable refrigerants, i.e. no sparking, adequately sealed or intrinsically safe.

2.5 Presence of fire extinguisher

- If any hot work is to be conducted on the refrigeration equipment or any associated parts, appropriate fire extinguishing equipment shall be available to hand. Have a dry powder or CO2 fire extinguisher adjacent to the charging area.

2.6 No ignition sources

- No person carrying out work in relation to a REFRIGERATING SYSTEM which involves exposing any pipe work shall use any sources of ignition in such a manner that it may lead to the risk of fire or explosion. All possible ignition sources, including cigarette smoking, should be kept sufficiently far away from the site of installation, repairing, removing and disposal, during which refrigerant can possibly be released to the surrounding space. Prior to work taking place, the area around the equipment is to be surveyed to make sure that there are no flammable hazards or ignition risks.
- "No Smoking" signs shall be displayed.

2.7 Ventilated area

- Ensure that the area is in the open or that it is adequately ventilated before breaking into the system or conducting any

hot work. A degree of ventilation shall continue during the period that the work is carried out. The ventilation should safely disperse any released refrigerant and preferably expel it externally into the atmosphere.

2.8 Checks to the refrigeration equipment

- Where electrical components are being changed, they shall be fit for the purpose and to the correct specification. At all times the manufacturer's maintenance and service guidelines shall be followed. If in doubt consult the manufacturer's technical department for assistance. The following checks shall be applied to installations using FLAMMABLE REFRIGERANTS:
 - the actual refrigerant charge is in accordance with the room size within which the refrigerant containing parts are installed;
 - the ventilation machinery and outlets are operating adequately and are not obstructed;
 - if an indirect refrigerating circuit is being used, the secondary circuits shall be checked for the presence of refrigerant;
 - marking to the equipment continues to be visible and legible, marking and signs that are illegible shall be corrected;
 - refrigeration pipe or components are installed in a position where they are unlikely to be exposed to any substance which may corrode refrigerant containing components, unless the components are constructed of materials which are inherently resistant to being corroded or are suitably protected against being so corroded.

2.9 Checks to electrical devices

- Repair and maintenance to electrical components shall include initial safety checks and component inspection procedures. If a fault exists that could compromise safety, then no electrical supply shall be connected to the circuit until it is satisfactorily dealt with. If the fault cannot be corrected immediately but it is necessary to continue operation, an adequate temporary solution shall be used. This shall be reported to the owner of the equipment so all parties are advised.

Initial safety checks shall include:

- that capacitors are discharged: this shall be done in a safe manner to avoid possibility of sparking;
- that there no live electrical components and wiring are exposed while charging, recovering or purging the system;
- that there is continuity of earth bonding.

2.10 Sealed electrical components shall be replaced

2.11 Intrinsically safe components must be replaced

2.12 Cabling

- Check that cabling will not be subject to wear, corrosion, excessive pressure, vibration, sharp edges or any other adverse environmental effects. The check shall also take into account the effects of aging or continual vibration from sources such as compressors or fans.

2.13 Detection of flammable refrigerants

- Under no circumstances shall potential sources of ignition be used in the searching for or detection of refrigerant leaks. A halide torch (or any other detector using a naked flame) shall not be used.
- The following leak detection methods are deemed acceptable for refrigerant systems. Electronic leak detectors may be used to detect refrigerant leaks but, in the case of FLAMMABLE REFRIGERANTS, the sensitivity may not be adequate, or may need re-calibration. (Detection equipment shall be calibrated in a refrigerant-free area.) Ensure that the detector is not a potential source of ignition and is suitable for the refrigerant used. Leak detection equipment shall be set at a percentage of the LFL of the refrigerant and shall be calibrated to the refrigerant employed, and the appropriate percentage of gas (25 % maximum) is confirmed. Leak detection fluids are also suitable for use with most refrigerants but the use of detergents containing chlorine shall be avoided as the chlorine may react with the refrigerant and corrode the copper pipe-work.

NOTE Examples of leak detection fluids are

- bubble method,
- fluorescent method agents.
- If a leak is suspected, all naked flames shall be removed/ extinguished.
- If a leakage of refrigerant is found which requires brazing, all of the refrigerant shall be recovered from the system, or isolated (by means of shut of valves) in a part of the system remote from the leak. See the following instructions of removal of refrigerant.

2.14 Removal and evacuation

- When breaking into the refrigerant circuit to make repairs or for any other purpose, conventional procedures shall be used. However, it is important that best practice is followed since flammability is a consideration.
- The following procedure shall be adhered to:
 - safely remove refrigerant following local and national regulations;
 - evacuate;
 - purge the circuit with inert gas(optional for A2L);
 - evacuate(optional for A2L);
 - continuously flush or purge with inert gas when using flame to open circuit; and open the circuit;
- The refrigerant charge shall be recovered into the correct recovery cylinders if venting is not allowed by local and

national codes. For appliances containing flammable refrigerants, the system shall be purged with oxygen-free nitrogen to render the appliance safe for flammable refrigerants. This process might need to be repeated several times. Compressed air or oxygen shall not be used for purging refrigerant systems.

- For appliances containing flammable refrigerants, refrigerants purging shall be achieved by breaking the vacuum in the system with oxygen-free nitrogen and continuing to fill until the working pressure is achieved, then venting to atmosphere, and finally pulling down to a vacuum (optional for A2L). This process shall be repeated until no refrigerant is within the system (optional for A2L). When the final oxygen-free nitrogen charge is used, the system shall be vented down to atmospheric pressure to enable work to take place.
- The outlet for the vacuum pump shall not be close to any potential ignition sources, and ventilation shall be available.

2.15 Charging procedures

- In addition to conventional charging procedures, the following requirements shall be followed:
 - Works shall be undertaken with appropriate tools only (In case of uncertainty, please consult the manufacturer of the tools for use with flammable refrigerants)
 - Ensure that contamination of different refrigerants does not occur when using charging equipment. Hoses or lines shall be as short as possible to minimize the amount of refrigerant contained in them.
 - Cylinders shall be kept upright.
 - Ensure that the refrigeration system is earthed prior to charging the system with refrigerant.
 - Label the system when charging is complete(if not already).
 - Extreme care shall be taken not to overfill the refrigeration system.
 - Prior to recharging the system it shall be pressure tested with OFN. The system shall be leak tested on completion of charging but prior to commissioning. A follow up leak test shall be carried out prior to leaving the site.

2.16 Decommissioning

Before carrying out this procedure, it is essential that the technician is completely familiar with the equipment and all its detail. It is recommended good practice that all refrigerants are recovered safely. Prior to the task being carried out, an oil and refrigerant sample shall be taken in case analysis is required prior to re-use of recovered refrigerant. It is essential that electrical power is available before the task is commenced.

- Become familiar with the equipment and its operation.
- Isolate system electrically.
- Before attempting the procedure ensure that:
 - mechanical handling equipment is available, if required, for handling refrigerant cylinders;
 - all personal protective equipment is available and being

- used correctly;
- the recovery process is supervised at all times by a competent person;
- recovery equipment and cylinders conform to the appropriate standards.
- Pump down refrigerant system, if possible.
- If a vacuum is not possible, make a manifold so that refrigerant can be removed from various parts of the system.
- Make sure that cylinder is situated on the scales before recovery takes place.
- Start the recovery machine and operate in accordance with manufacturer's instructions.
- Do not overfill cylinders. (No more than 80 % volume liquid charge).
- Do not exceed the maximum working pressure of the cylinder, even temporarily.
- When the cylinders have been filled correctly and the process completed, make sure that the cylinders and the equipment are removed from site promptly and all isolation valves on the equipment are closed off.
- Recovered refrigerant shall not be charged into another refrigeration system unless it has been cleaned and checked.

2.17 Labelling

- Equipment shall be labelled stating that it has been de-commissioned and emptied of refrigerant. The label shall be dated and signed. For appliances containing FLAMMABLE REFRIGERANTS, ensure that there are labels on the equipment stating the equipment contains FLAMMABLE REFRIGERANT.

2.18 Recovery

- When removing refrigerant from a system, either for servicing or decommissioning,
- it is recommended good practice that all refrigerants are removed safely.
- When transferring refrigerant into cylinders, ensure that only appropriate refrigerant recovery cylinders are employed. Ensure that the correct number of cylinders for holding the total system charge is available. All cylinders to be used are designated for the recovered refrigerant and labelled for that refrigerant (i. e. special cylinders for the recovery of refrigerant). Cylinders shall be complete with pressure-relief valve and associated shut-of valves in good working order. Empty recovery cylinders are evacuated and, if possible, cooled before recovery occurs.
- The recovery equipment shall be in good working order with a set of instructions concerning the equipment that is at hand and shall be suitable for the recovery of the flammable refrigerant. If in doubt the manufacturer should be consulted. In addition, a set of calibrated weighing scales shall be available and in good working order. Hoses shall be complete with leak-free disconnect couplings and in good condition.

- The recovered refrigerant shall be processed according to local legislation in the correct recovery cylinder, and the relevant waste transfer note arranged. Do not mix refrigerants in recovery units and especially not in cylinders.
- If compressors or compressor oils are to be removed, ensure that they have been evacuated to an acceptable level to make certain that flammable refrigerant does not remain within the lubricant. The compressor body shall not be heated by an open flame or other ignition sources to accelerate this process. When oil is drained from a system, it shall be carried out safely.

2.19 Transportation, marking and storage for units

1. Transport of equipment containing flammable refrigerants

Compliance with the transport regulations

2. Marking of equipment using signs

Compliance with local regulations

3. Disposal of equipment using flammable refrigerants

Compliance with national regulations

4. Storage of equipment/appliances

The storage of equipment should be in accordance with the manufacturer's instructions.

5. Storage of packed (unsold) equipment

Storage package protection should be constructed such that mechanical damage to the equipment inside the package will not cause a leak of the refrigerant charge. The maximum number of pieces of equipment permitted to be stored together will be determined by local regulations.

Specifications

Contents

1.	Model Reference.....	2
2.	Pipe Length and Drop Height.....	3
3.	Indoor units combination	6
4.	Refrigeration Cycle Diagrams.....	18
5.	Electrical Wiring Diagrams.....	20

1. Model Reference

Refer to the following table to determine the specific outdoor unit model.

Indoor Unit Model	Outdoor Unit Model	Capacity (Btu/h)	Power Supply
B-VHP183A-1	A-VHP183A-1	18k Hyper Heat Series	208/230V~, 60Hz, 1 Phase
B-VHP284A-1	A-VHP284A-1	27k Hyper Heat Series	
B-VHP365A-1	A-VHP365A-1	36k Hyper Heat Series	
B-VHP486A-1	A-VHP486A-1	48k Hyper Heat Series	
B-VHP556A-1	A-VHP556A-1	55k Hyper Heat Series	

2. Pipe Length and Drop Height

Ensure that the length of the refrigerant pipe and the drop height between the indoor and outdoor units meets the requirements shown in the following table.

	1 drive 2	1 drive 3	1 drive 4	1 drive 5	1 drive 6
Max. length for all rooms (ft/m)	131/40	197/60	262/80	262/80	262/80
Max. length for one IU (ft/m)	82/25	98/30	115/35	115/35	115/35
Max. height difference between IU and OU (ft/m)	49/15	49/15	49/15	49/15	49/15
Max. height difference between IUs (ft/m)	33/10	33/10	33/10	33/10	33/10

Caution:

- Refrigerant pipe diameter is different according to indoor unit to be connected. When using the extension pipe, refer to the tables below.
- When refrigerant pipe diameter is different from that of outdoor unit union, additional transfer connector needs to be used on outdoor unit.

Indoor unit		
Model	Pipe diameter (inch(mm))	
6k,9k,12k	Liquid	Φ1/4(Φ6.35)
	Gas	Φ3/8(Φ9.52)
18k	Liquid	Φ1/4(6.35)
	Gas	Φ1/2(Φ12.7)
24k,33k	Liquid	Φ3/8(Φ9.52)
	Gas	Φ5/8(Φ16)

Outdoor unit				
Model	Pipe diameter (inch(mm))		Adaptor(inch(mm))	Qty
A-VHP183A-1	Liquid	Φ1/4(Φ6.35)*3	Φ3/8(Φ9.52)-->Φ1/2(Φ12.7)	2
	Gas	Φ3/8(Φ9.52)*3	Φ1/2(Φ12.7)-->Φ5/8(Φ16)	1
A-VHP284A-1	Liquid	Φ1/4(6.35)*4	Φ1/4(Φ6.35)-->Φ3/8(Φ9.52)	1
	Gas	Φ3/8(Φ9.52)*3	Φ1/2(Φ12.7)-->Φ5/8(Φ16)	1
		Φ3/8(Φ9.52)-->Φ1/2(Φ12.7)	Φ3/8(Φ9.52)-->Φ1/2(Φ12.7)	1
		Φ1/2(Φ12.7)*1	Φ1/2(Φ12.7)-->Φ3/8(Φ9.52)	1
A-VHP365A-1	Liquid	Φ1/4(6.35)*5	Φ1/4(Φ6.35)-->Φ3/8(Φ9.52)	2
	Gas	Φ3/8(Φ9.52)*3	Φ1/2(Φ12.7)-->Φ5/8(Φ16)	2
		Φ1/2(Φ12.7)*2	Φ3/8(Φ9.52)-->Φ1/2(Φ12.7)	1
		Φ1/2(Φ12.7)-->Φ3/8(Φ9.52)	Φ1/2(Φ12.7)-->Φ3/8(Φ9.52)	2
A-VHP486A-1	Liquid	Φ1/4(6.35)*6	Φ1/4(Φ6.35)-->Φ3/8(Φ9.52)	2
	Gas	Φ3/8(Φ9.52)*4	Φ1/2(Φ12.7)-->Φ5/8(Φ16)	2
Φ3/8(Φ9.52)-->Φ1/2(Φ12.7)		Φ3/8(Φ9.52)-->Φ1/2(Φ12.7)	1	
A-VHP556A-1		Φ1/2(Φ12.7)*2	Φ1/2(Φ12.7)-->Φ3/8(Φ9.52)	2

3. Indoor units combination

3.1 Indoor unit combination for A-VHP183A-1

Available Indoor	One unit	Two units		Three units	
Wall mounted(AG/EP): 6K/9K/12K/18K/24K; Cassette/Low Static Slim Duct/ console: 6K/9K/12K/18K/24K;	18	6+6	9+18	6+6+6	6+12+12
	24	6+9	9+24	6+6+9	6+12+18
		6+12	12+12	6+6+12	9+9+9
		6+18	12+18	6+6+18	9+9+12
		6+24	12+24	6+6+24	9+9+18
		9+9	18+18	6+9+9	9+12+12
		9+12		6+9+12	12+12+12
				6+9+18	
Wall mounted(AG/EP): 6K/9K/12K; Cassette/Low Static Slim Duct/Console: 6K/9K/12K; AHU:18K/24K (At least one AHU)	18	6+18		6+6+18	
	24	9+18		6+9+18	
		12+18		9+9+18	
High Static Slim Duct:9K/12K/18K/24K	9	9+9	12+12		
	12	9+12	12+18		
	18	9+18	12+24		
	24	9+24			

3.2 Indoor unit combination for A-VHP284A-1

Available Indoor	One unit	Two units	Three units			
Wall mounted(AG/EP): 6K/ 9K/12K/18K/24K/30K; Cassette/Low Static Slim Duct/Console: 6K/9K/12K/18K/24K;	24	6+18	6+6+6	6+12+12	9+12+12	
	30	6+24	6+6+9	6+12+18	9+12+18	
		9+9	6+6+12	6+12+24	9+12+24	
		9+12	6+6+18	6+18+18	9+18+18	
		9+18	6+6+24	6+18+24	12+12+12	
		9+24	6+9+9	9+9+9	12+12+18	
		12+12	6+9+12	9+9+12	12+12+24	
		12+18	6+9+18	9+9+18	12+18+18	
		12+24	6+9+24	9+9+24		
		18+18				
	Four units					
		6+6+6+6	6+6+9+12	6+6+18+18	6+9+12+18	9+9+9+18
		6+6+6+9	6+6+9+18	6+9+9+9	6+12+12+12	9+9+12+12
		6+6+6+12	6+6+9+24	6+9+9+12	6+12+12+18	9+9+12+18
		6+6+6+18	6+6+12+12	6+9+9+18	9+9+9+9	9+12+12+12
		6+6+6+24	6+6+12+18	6+9+9+24	9+9+9+12	12+12+12+12
	6+6+9+9	6+6+12+24	6+9+12+12			
High Static Slim Duct:9K/12K/18K/24K	One unit	Two units		Three units		
	18	9+9	12+12	9+9+9	9+12+18	
	24	9+12	12+18	9+9+12	9+12+24	
		9+18	12+24	9+9+18	12+12+12	
		9+24		9+9+24	12+12+18	
				9+12+12	12+12+24	

Available Indoor	One unit	Two units	Three units	Four units
Wall mounted(AG/EP): 6K/9K/12K/18K; Cassette/Low Static Slim Duct/ Console: 6K/9K/12K/18K; AHU: 18K/24K/30K (At least one AHU)	24	6+18	6+6+18	6+6+6+18
	30	6+24	6+6+24	6+6+6+24
		9+18	6+9+18	6+6+9+18
		9+24	6+9+24	6+6+9+24
		12+18	6+12+18	6+9+9+18
		12+24	6+12+24	6+9+9+24
		18+18	9+9+18	9+9+9+18
			9+9+24	
			9+12+18	
			9+12+24	
			12+12+18	
			12+12+24	

3.3 Indoor unit combination for A-VHP365A-1

Available Indoor	One unit	Two units		Three units			
Wall mounted(AG/EP): 6K/9K/12K/18K/24K/30K/36K; Cassette/Low Static Slim Duct/Console: 6K/9K/12K/18K/24K	30	6+24	12+18	6+6+12	6+12+18	9+12+18	
	36	6+30	12+24	6+6+18	6+12+24	9+12+24	
		6+36	12+30	6+6+24	6+12+30	9+18+18	
		9+18	12+36	6+6+30	6+18+18	9+18+24	
		9+24	18+18	6+6+36	6+18+24	12+12+12	
		9+30	18+24	6+9+9	9+9+9	12+12+18	
		9+36	18+30	6+9+12	9+9+12	12+12+24	
		12+12	24+24	6+9+18	9+9+18	12+18+18	
				6+9+24	9+9+24	12+18+24	
				6+9+30	9+9+30	18+18+18	
				6+12+12	9+12+12		
	Four units			Five units			
		6+6+6+6	6+6+18+18	6+12+12+18	9+9+18+18	6+6+6+6+6	6+6+9+9+12
		6+6+6+9	6+6+18+24	6+12+12+24	9+9+18+24	6+6+6+6+9	6+6+9+9+18
		6+6+6+12	6+9+9+9	6+12+18+18	9+12+12+12	6+6+6+6+12	6+6+9+12+12
		6+6+6+18	6+9+9+12	6+12+18+24	9+12+12+18	6+6+6+6+18	6+6+12+12+12
		6+6+6+24	6+9+9+18	6+18+18+18	9+12+12+24	6+6+6+9+9	6+9+9+9+9
		6+6+9+9	6+9+9+24	9+9+9+9	9+12+18+18	6+6+6+9+12	6+9+9+9+12
		6+6+9+12	6+9+12+12	9+9+9+12	9+18+18+18	6+6+6+9+18	6+9+9+12+12
		6+6+9+18	6+9+12+18	9+9+9+18	12+12+12+12	6+6+6+12+12	9+9+9+9+9
	6+6+9+24	6+9+12+24	9+9+9+24	12+12+12+18	6+6+6+12+18	9+9+9+9+12	
	6+6+12+12	6+9+18+18	9+9+12+12	12+12+12+24	6+6+9+9+9		
	6+6+12+18	6+9+18+24	9+9+12+18	12+12+18+18			
	6+6+12+24	6+12+12+12	9+9+12+24				

Available Indoor	One unit	Two units	Three units	Four units			
High Static Slim Duct: 9K/12K/18K/24K	18	9+9	12+18	9+9+9	9+12+18	9+9+9+9	9+12+12+12
	24	9+12	12+24	9+9+12	9+12+24	9+9+9+12	9+12+12+18
		9+18	18+18	9+9+18	12+12+12	9+9+9+18	9+12+12+24
		9+24	18+24	9+9+24	12+12+18	9+9+9+24	12+12+12+12
		12+12	24+24	9+12+12	12+12+24	9+9+12+12	12+12+12+18
						9+9+12+18	12+12+12+24
						9+9+12+24	

Available Indoor	One unit	Two units	Three units	Four units	Five units	
Wall mounted(AG/EP): 6K/9K/12K/18K/24K/30K/36K; Cassette/Low Static Slim Duct/Console: 6K/9K/12K/18K/24K; AHU: 18K/24K/30K/36K (At least one AHU)	30	6+18	12+18	6+6+18	6+12+30	
	36	6+24	12+24	6+6+24	9+9+18	
		6+30	12+30	6+6+30	9+9+24	
		6+36	12+36	6+6+36	9+9+30	
		9+18	18+18	6+9+18	9+12+18	
		9+24	18+24	6+9+24	9+12+24	
		9+30	18+30	6+9+30	12+12+18	
		9+36	24+24	6+12+18	12+12+24	
				6+12+24		
	Four units			Five units		
		6+6+6+18	6+6+12+24	6+12+12+18	9+9+12+24	6+6+6+6+18
		6+6+6+24	6+9+9+18	6+12+12+24	9+12+12+18	6+6+6+9+18
		6+6+9+18	6+9+9+24	9+9+9+18	9+12+12+24	6+6+9+9+18
		6+6+9+24	6+9+12+18	9+9+9+24	12+12+12+18	
		6+6+12+18	6+9+12+24	9+9+12+18	12+12+12+24	

3.4 Indoor unit combination for A-VHP486A-1, A-VHP556A-1

Available Indoor	One unit	Two units		Three units				
Wall mounted(AG/EP): 6K/9K/12K/18K/24K/30K/36K; Cassette/Low Static Slim Duct/Console: 6K/9K/12K/18K/24K;	30	6+24	12+30	6+6+18	6+12+18	9+9+24	9+18+36	
	36	6+30	12+36	6+6+24	6+12+24	9+9+30	12+12+12	
		6+36	18+18	6+6+30	6+12+30	9+9+36	12+12+18	
		9+18	18+24	6+6+36	6+12+36	9+12+12	12+12+24	
		9+24	18+30	6+9+9	6+18+18	9+12+18	12+12+30	
		9+30	18+36	6+9+12	6+18+24	9+12+24	12+12+36	
		9+36	24+24	6+9+18	6+18+30	9+12+30	12+18+18	
		12+12	24+30	6+9+24	6+18+36	9+12+36	12+18+24	
		12+18	24+36	6+9+30	9+9+9	9+18+18	12+18+30	
		12+24		6+9+36	9+9+12	9+18+24	12+18+36	
				6+12+12	9+9+18	9+18+30	18+18+18	
	Four units							
		6+6+6+6	6+6+9+24	6+9+9+18	6+12+12+12	9+9+9+9	9+9+18+18	9+18+18+18
		6+6+6+9	6+6+12+12	6+9+9+24	6+12+12+18	9+9+9+12	9+9+18+24	12+12+12+12
		6+6+6+12	6+6+12+18	6+9+12+12	6+12+12+24	9+9+9+18	9+12+12+12	12+12+12+18
		6+6+6+18	6+6+12+24	6+9+12+18	6+12+18+18	9+9+9+24	9+12+12+18	12+12+12+24
		6+6+6+24	6+6+18+18	6+9+12+24	6+12+18+24	9+9+12+12	9+12+12+24	12+12+18+18
		6+6+9+9	6+6+18+24	6+9+18+18	6+18+18+18	9+9+12+18	9+12+18+18	12+12+18+24
		6+6+9+12	6+9+9+9	6+9+18+24	6+18+18+24	9+9+12+24	9+12+18+24	12+18+18+18
		6+6+9+18	6+9+9+12					
	Five units							
		6+6+6+6+6	6+6+6+12+24	6+6+9+18+24	6+9+9+9+24	6+9+12+18+24	9+9+9+9+24	9+9+12+18+24
		6+6+6+6+9	6+6+6+18+18	6+6+12+12+12	6+9+9+12+12	6+9+18+18+18	9+9+9+12+12	9+9+18+18+18
		6+6+6+6+12	6+6+6+18+24	6+6+12+12+18	6+9+9+12+18	6+12+12+12+12	9+9+9+12+18	9+12+12+12+12
		6+6+6+6+18	6+6+9+9+9	6+6+12+12+24	6+9+9+12+24	6+12+12+12+18	9+9+9+12+24	9+12+12+12+18
		6+6+6+6+24	6+6+9+9+12	6+6+12+18+18	6+9+9+18+18	6+12+12+12+24	9+9+9+18+18	9+12+12+12+24
		6+6+6+9+9	6+6+9+9+18	6+6+12+18+24	6+9+9+18+24	6+12+12+18+18	9+9+9+18+24	9+12+12+18+18
		6+6+6+9+12	6+6+9+9+24	6+6+18+18+18	6+9+12+12+12	6+12+18+18+18	9+9+12+12+12	12+12+12+12+12
	6+6+6+9+18	6+6+9+12+12	6+6+18+18+24	6+9+12+12+18	9+9+9+9+9	9+9+12+12+18	12+12+12+12+18	
	6+6+6+9+24	6+6+9+12+18	6+9+9+9+9	6+9+12+12+24	9+9+9+9+12	9+9+12+12+24	12+12+12+12+24	
	6+6+6+12+12	6+6+9+12+24	6+9+9+9+12	6+9+12+18+18	9+9+9+9+18	9+9+12+18+18	12+12+12+18+18	
	6+6+6+12+18	6+6+9+18+18	6+9+9+9+18					
Six units								
	6+6+6+6+6+6	6+6+6+6+12+12	6+6+6+9+12+24	6+6+9+9+12+18	6+9+9+9+9+12	6+9+12+12+12+12	9+9+9+9+12+18	
	6+6+6+6+6+9	6+6+6+6+12+18	6+6+6+12+12+12	6+6+9+9+12+24	6+9+9+9+9+18	6+9+12+12+12+18	9+9+9+9+12+24	
	6+6+6+6+6+12	6+6+6+6+12+24	6+6+6+12+12+18	6+6+9+9+12+12+12	6+9+9+9+9+24	6+12+12+12+12+12	9+9+9+12+12+12	
	6+6+6+6+6+18	6+6+6+9+9+9	6+6+6+12+12+24	6+6+9+9+12+12+18	6+9+9+9+12+12	6+12+12+12+12+18	9+9+9+12+12+18	
	6+6+6+6+6+24	6+6+6+9+9+12	6+6+9+9+9+9	6+6+9+12+12+24	6+9+9+9+12+18	9+9+9+9+9+9	9+9+12+12+12+12	
	6+6+6+6+9+9	6+6+6+9+9+18	6+6+9+9+9+12	6+6+12+12+12+12	6+9+9+9+12+24	9+9+9+9+9+12	9+9+12+12+12+18	
	6+6+6+6+9+12	6+6+6+9+9+24	6+6+9+9+9+18	6+6+12+12+12+18	6+9+9+12+12+12	9+9+9+9+9+18	9+12+12+12+12+12	
	6+6+6+6+9+18	6+6+6+9+12+12	6+6+9+9+9+24	6+6+12+12+12+24	6+9+9+12+12+18	9+9+9+9+9+24	12+12+12+12+12+12	
	6+6+6+6+9+24	6+6+6+9+12+18	6+6+9+9+12+12	6+9+9+9+9+9	6+9+9+12+12+24	9+9+9+9+12+12		

A-VHP486A-1, A-VHP556A-1

Available Indoor	One unit	Two units		Three units		Four units		
High Static Slim Duct: 9K/12K/18K/24K	18	9+9	12+18	9+9+9	9+18+24	9+9+9+9	9+12+12+18	9+9+9+9+9
	24	9+12	12+24	9+9+12	9+24+24	9+9+9+12	9+12+12+24	9+9+9+9+12
		9+18	18+18	9+9+18	12+12+12	9+9+9+18	9+12+18+18	9+9+9+12+12
		9+24	18+24	9+9+24	12+12+18	9+9+9+24	9+12+18+24	9+9+12+12+12
		12+12	24+24	9+12+12	12+12+24	9+9+12+12	12+12+12+12	9+12+12+12+12
				9+12+18	12+18+18	9+9+12+18	12+12+12+18	12+12+12+12+12
				9+12+24	12+18+24	9+9+12+24	12+12+12+24	
				9+18+18	12+24+24	9+9+18+18	12+12+18+18	
						9+9+18+24	12+12+18+24	
					9+12+12+12			

Available Indoor	One unit	Two units		Three units			
Wall mounted(AG/EP): 6K/9K/12K/18K/24K/30K/36K; Cassette/Low Static Slim Duct/ Console: 6K/9K/12K/18K/24K; AHU: 18K/24K/30K/36K (At least one AHU)	30	6+18	12+30	6+6+18	9+9+18		
	36	6+24	12+36	6+6+24	9+9+24		
		6+30	18+18	6+6+30	9+9+30		
		6+36	18+24	6+6+36	9+9+36		
		9+18	18+30	6+9+18	9+12+18		
		9+24	18+36	6+9+24	9+12+24		
		9+30	24+24	6+9+30	9+12+30		
		9+36	24+30	6+9+36	9+12+36		
		12+18	24+36	6+12+18	12+12+18		
		12+24		6+12+24	12+12+24		
				6+12+30	12+12+30		
				6+12+36			
	Four units						
		6+6+6+18	6+6+12+18	6+9+12+18	9+9+9+18	9+12+12+18	
		6+6+6+24	6+6+12+24	6+9+12+24	9+9+9+24	9+12+12+24	
		6+6+9+18	6+9+9+18	6+12+12+18	9+9+12+18	12+12+12+18	
		6+6+9+24	6+9+9+24	6+12+12+24	9+9+12+24	12+12+12+24	
	Five units					Six units	
		6+6+6+6+18	6+9+9+9+24	6+9+12+12+24	9+9+9+12+24	6+6+6+6+6+18	
		6+6+6+6+24	6+9+9+12+18	6+12+12+12+18	9+9+9+12+18	6+6+6+6+9+18	
		6+6+6+12+18	6+9+9+12+24	9+9+9+9+18	9+9+12+12+18	6+6+6+9+9+18	
		6+6+6+12+24	6+9+12+12+18	9+9+9+9+24	9+12+12+12+18	6+6+9+9+9+18	
		6+9+9+9+18				6+9+9+9+9+18	
					9+9+9+9+9+18		

4.7 Refrigeration Cycle Diagram of A-VHP183A-1

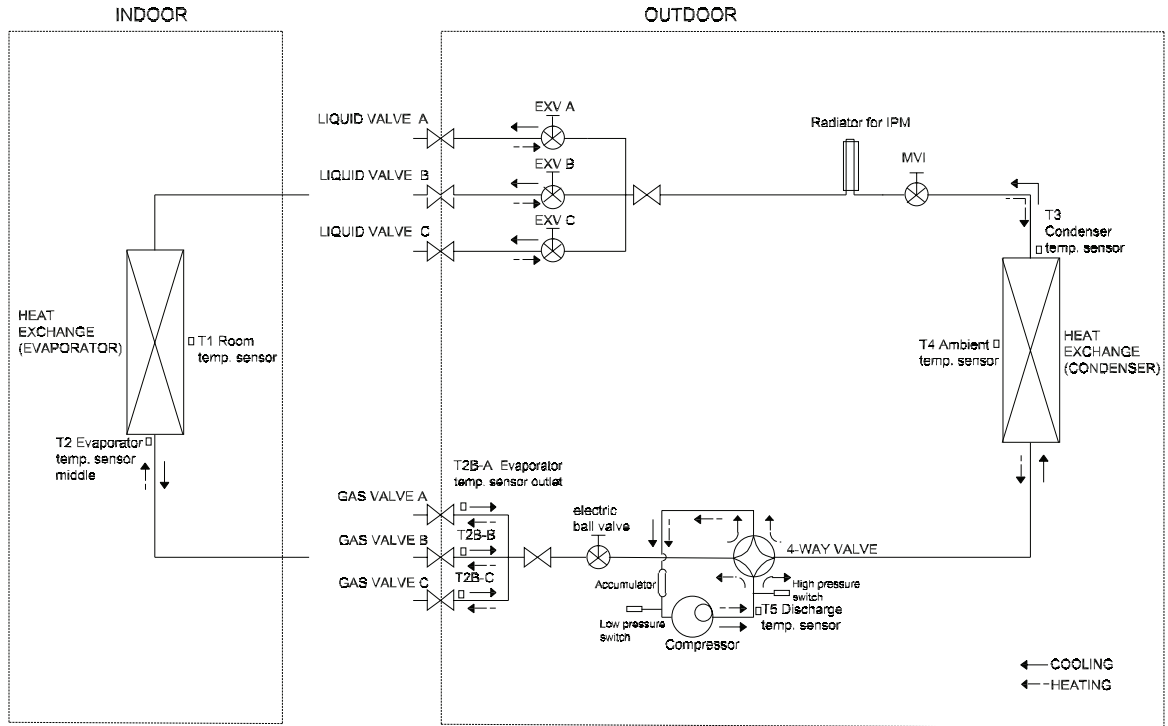

4.8 Refrigeration Cycle Diagram of A-VHP284A-1

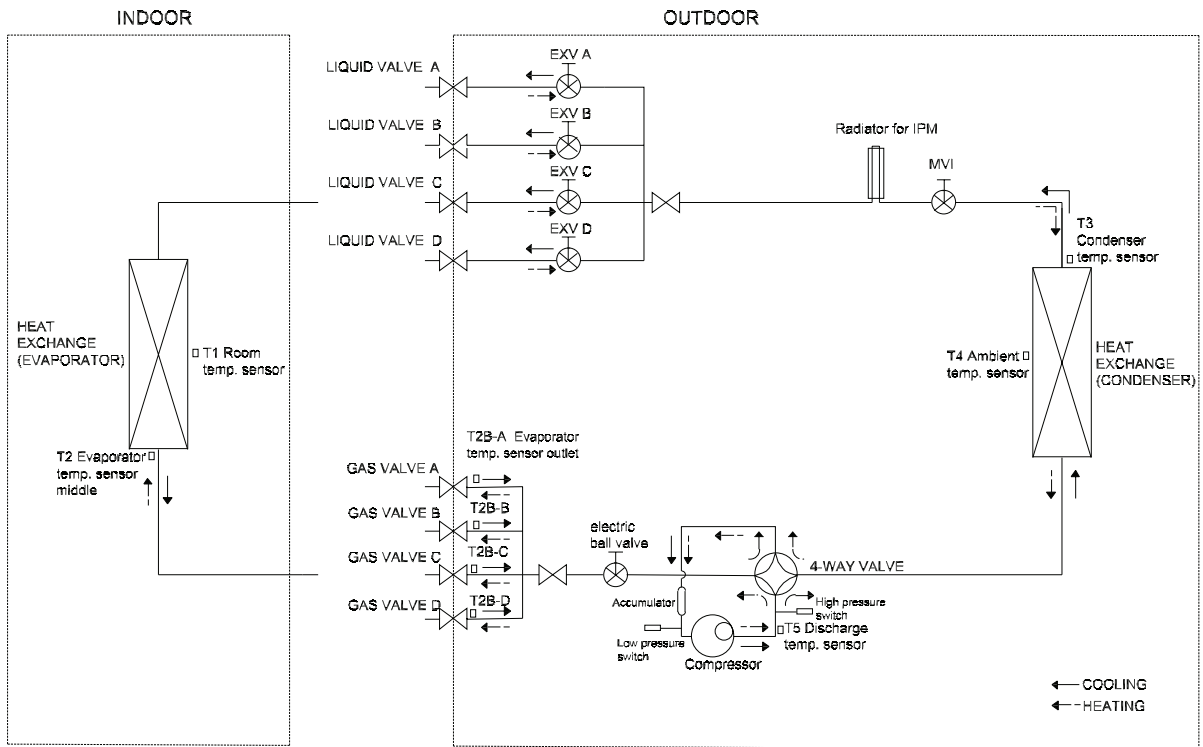

4.10 Refrigeration Cycle Diagram of A-VHP365A-1

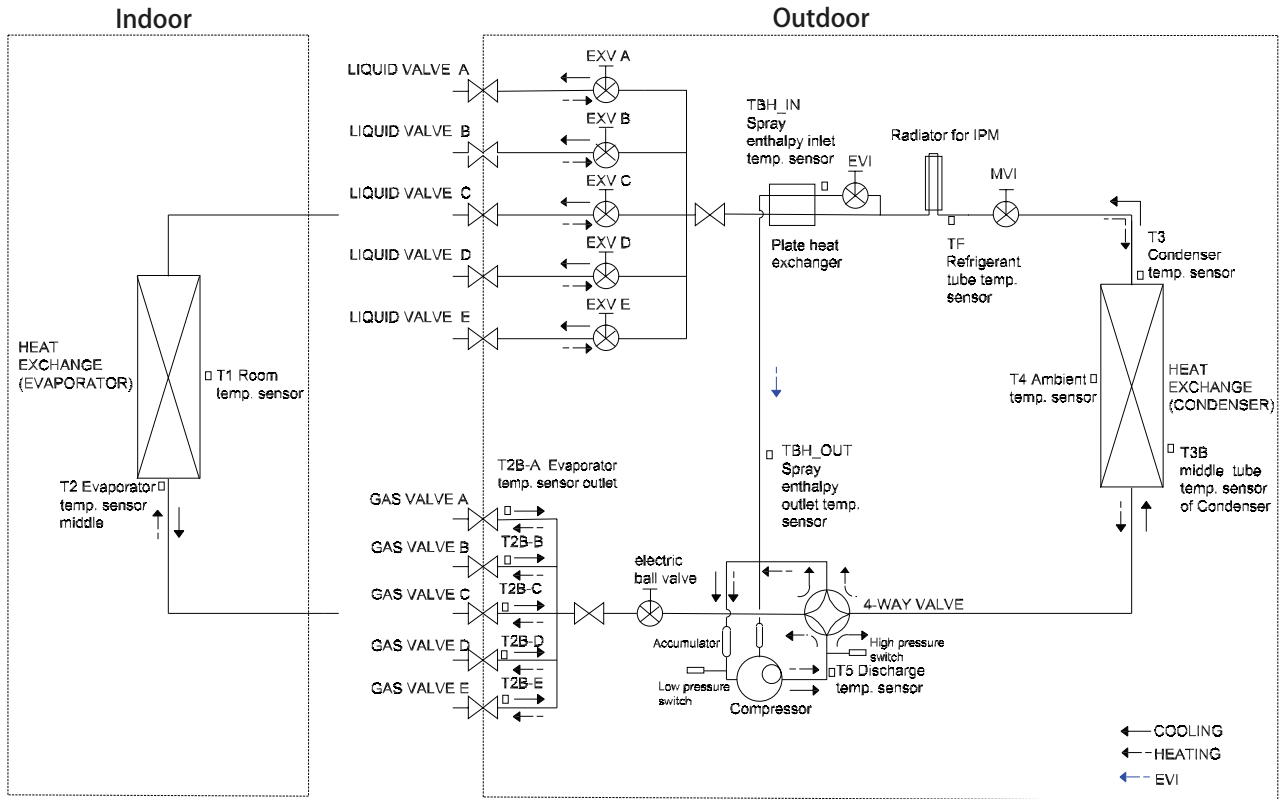

4.12 Refrigeration Cycle Diagram of A-VHP486A-1, A-VHP556A-1

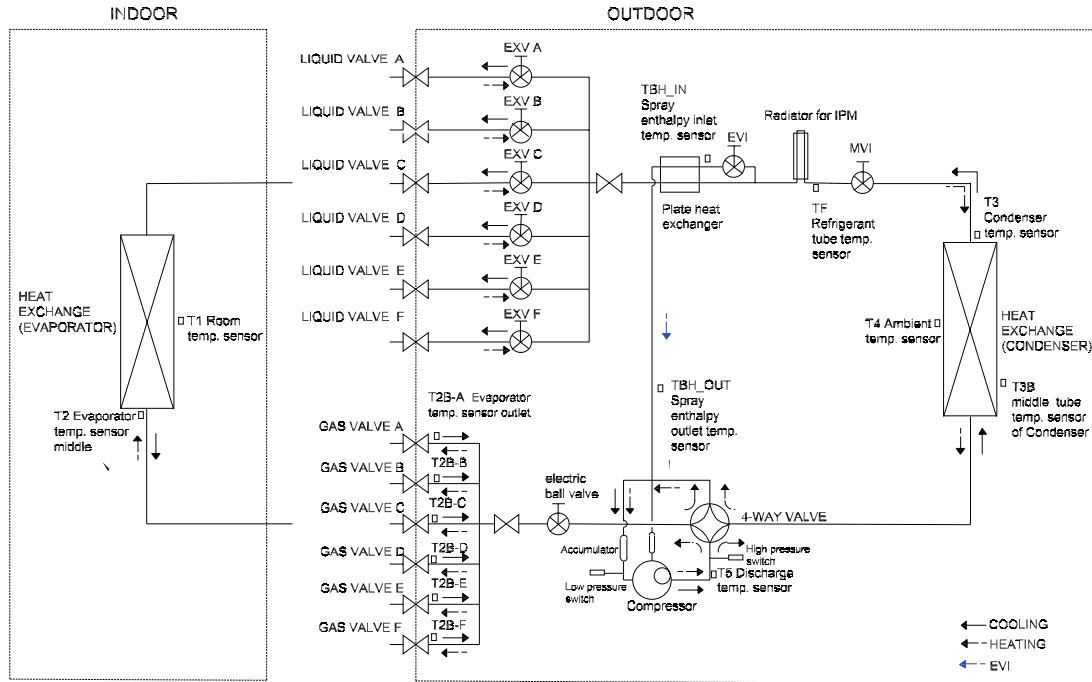

5. Electrical Wiring Diagrams

Outdoor unit wiring diagram

Outdoor Unit	
ODU Model	ODU Wiring Diagram
A-VHP183A-1	16022300005874
A-VHP284A-1	16022300005875
A-VHP365A-1	16022300005713
A-VHP486A-1 A-VHP556A-1	16022000041470

Outdoor unit printed circuit board diagram

Outdoor Unit	
ODU Model	ODU Printed Circuit Board
A-VHP183A-1	17122300008875
A-VHP284A-1 A-VHP365A-1	17122300008875
A-VHP486A-1 A-VHP556A-1	17122300008875

Outdoor unit wiring diagram:16022300005874

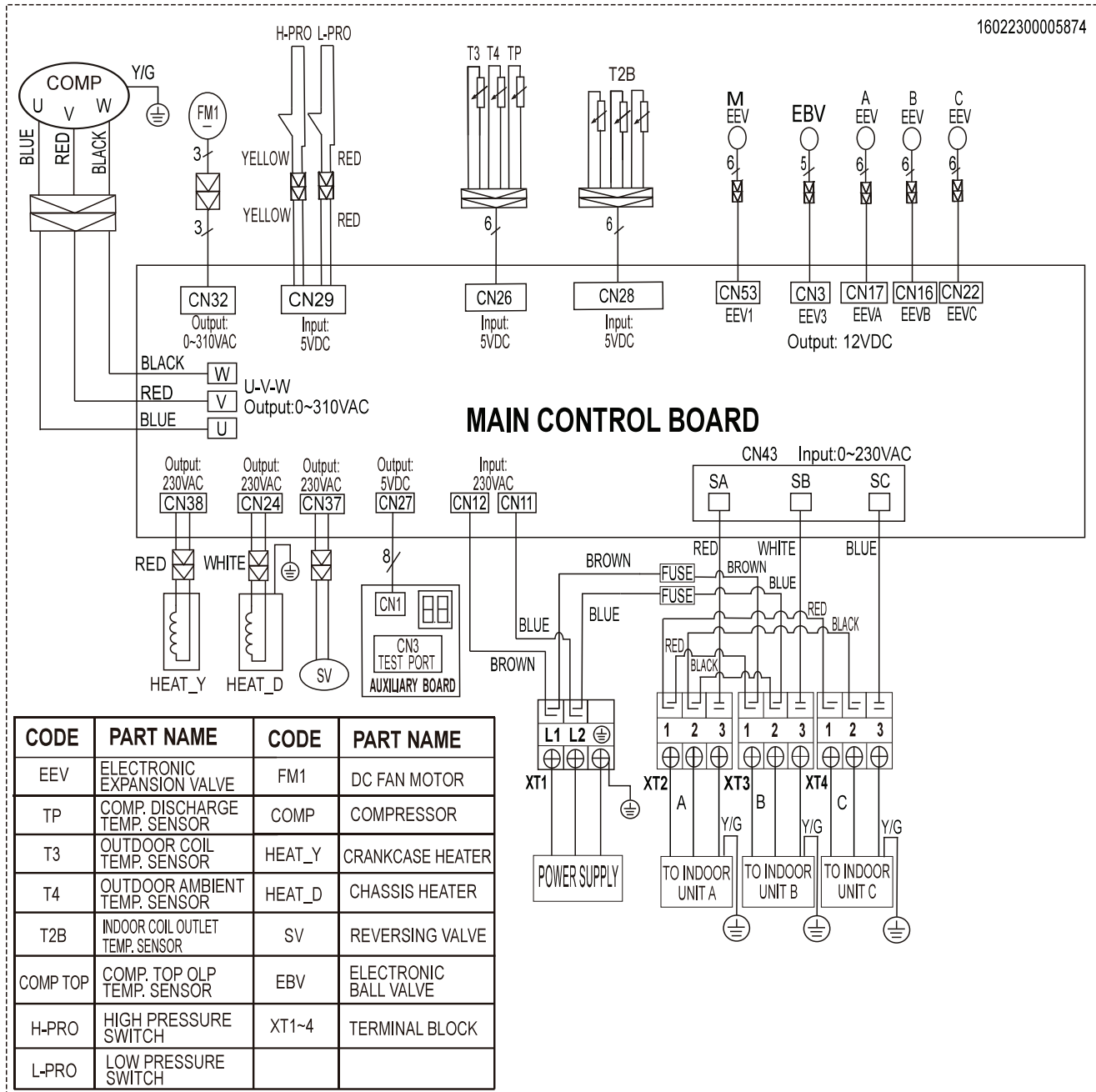

Outdoor unit wiring diagram:16022300005875

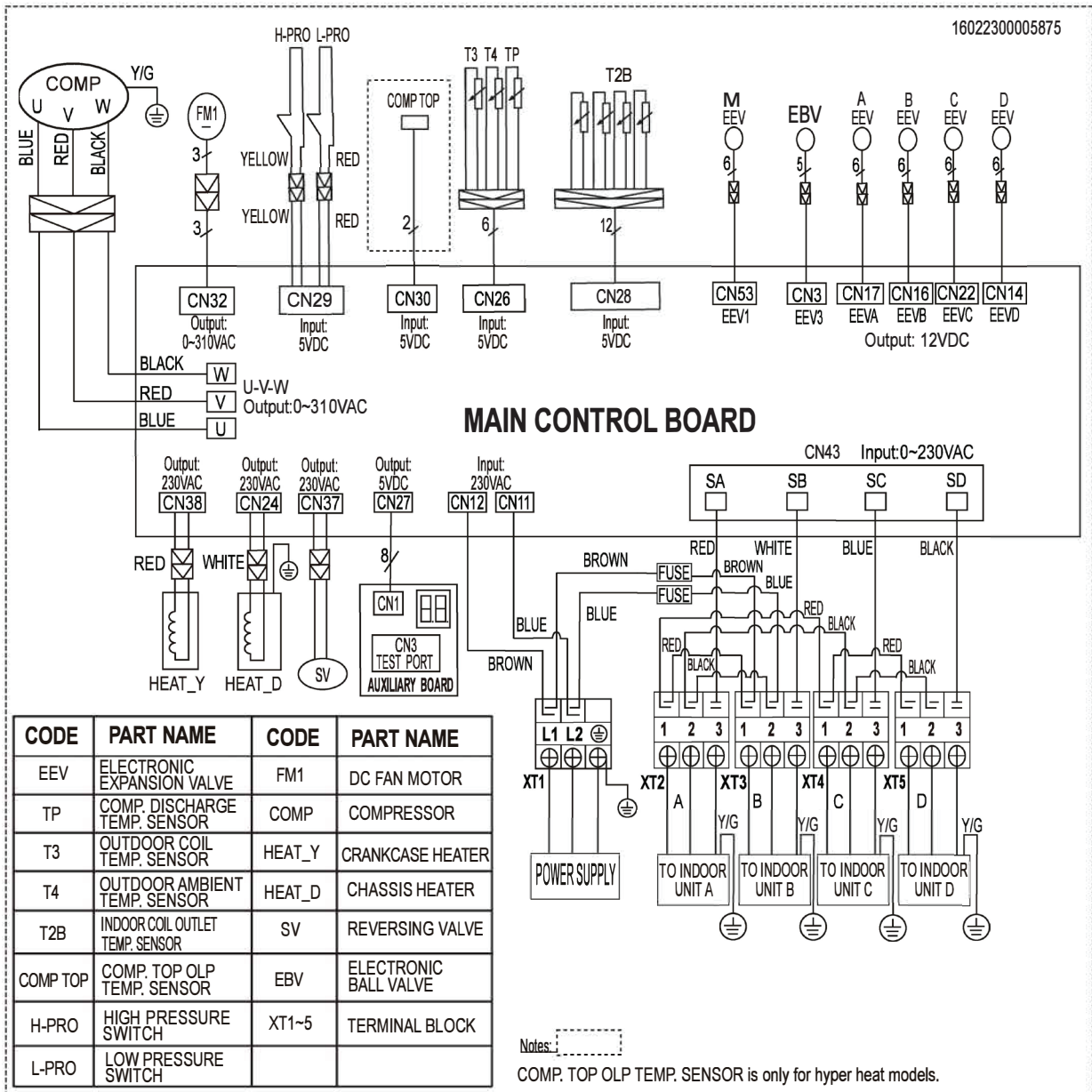

Outdoor unit printed circuit board diagram: 17122300008875

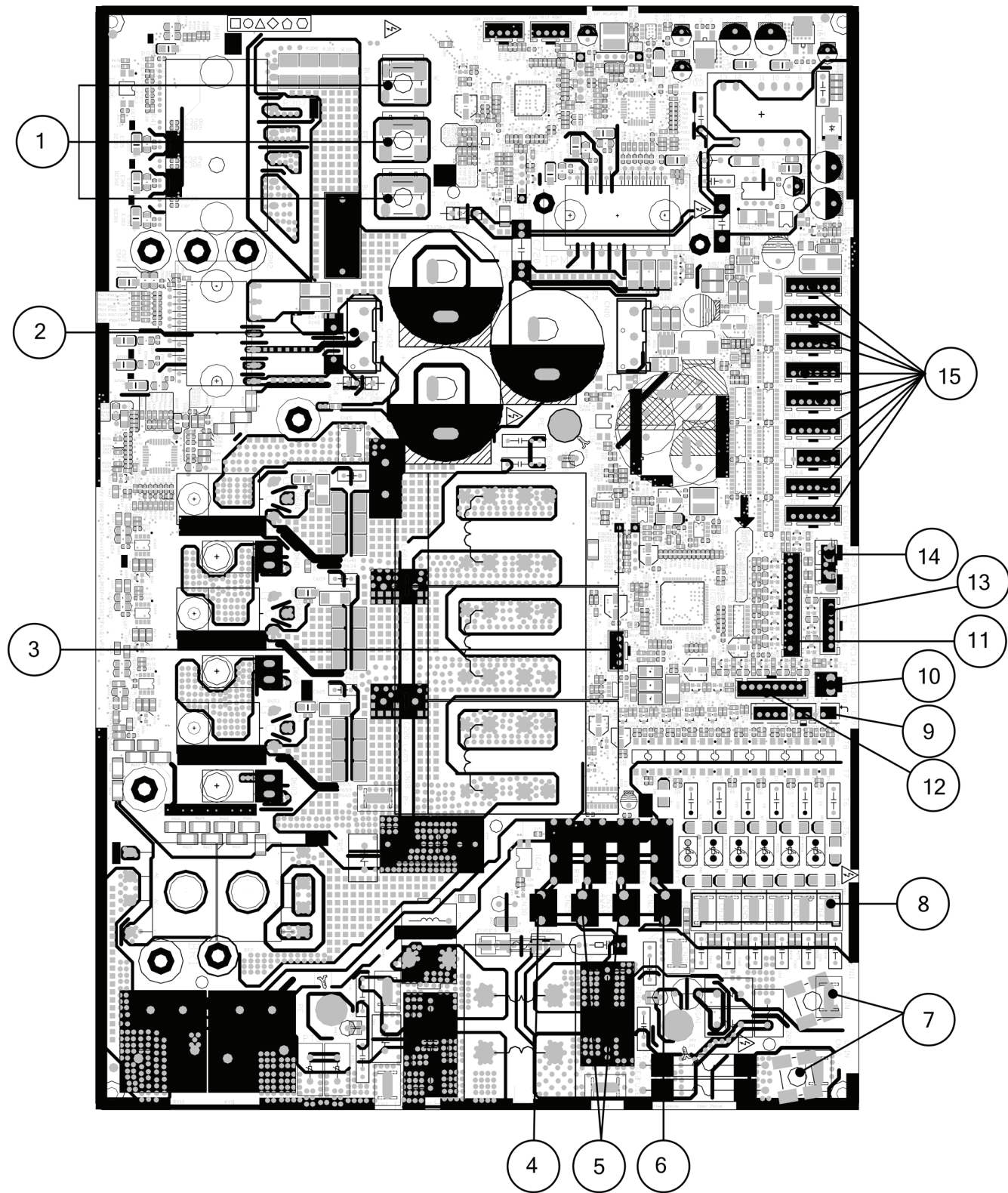

No.	Name	CN#	Meaning
1	COMPRESSOR	W	connect to compressor; 0V AC (standby); 10-310V AC (running)
		V	
		U	
2	DC-FAN	CN32	connect to DC fan
3	TESTPORT	CN45	used for testing
4	HEAT_Y	CN38	connect to compressor heater, 208-230V AC when is ON
5	4-WAY	CN37	connect to 4 way valve 1, 208-230V AC when is ON.
		CN25	connect to 4 way valve 2, 208-230V AC when is ON.
6	HEAT_D	CN24	connect to chassis heater, 208-230V AC when is ON
7	Power Supply	CN11	N_in: connect to N-line (208-230V AC input)
		CN12	L_in: connect to L-line (208-230V AC input)
8	S-A	CN43	S: connect to indoor unit communication(pin1-pin2: 24VDC Pulse wave; pin2-pin3: 208-230V AC input)
	S-B		
	S-C		
	S-D		
	S-E		
	S-F		
9	TBH-IN TBH-OUT T3B TF	CN9	connect to cold plate inlet temp. sensor TBH-IN, cold plate outlet temp. sensor TBH-OUT, condenser coil middle temp. sensor T3B, refrigerant tube inlet temp. sensor TF
10	OLP TEMP. SENSOR	CN30	connect to compressor top temp. sensor (5VDC Pulse wave)
11	T2B	CN28	connect to evaporator coil outlet temperature sensor T2B
12	/	CN27	connect to key board CN1
13	T3 T4 TP	CN26	connect to condenser coil temp. sensor T3, ambient temp. sensor T4, exhaust temp. sensor TP
14	H-PRO,L-RPO	CN29	connect to high and low pressure switch(pin1-pin2&pin3-pin4:5VDC pulse wave)

No.	Name	CN#	Meaning
15	EEVA	CN17	connect to electric expansion valve
	EEVB	CN16	
	EEVC	CN22	
	EEVD	CN14	
	EEVE	CN13	
	EEVF	CN1	
	EEV1	CN53	
	EEV2	CN44	
	EEV3	CN3	

Note: This section is for reference only. Please take practicality as standard.

Electronic Functions

Contents

1	Abbreviation	2
2	Main Protection	2

1. Abbreviation

Unit element abbreviations

Abbreviation	Element
T1	Indoor room temperature
T2	Middle indoor heat exchanger coil temperature
T2B	Indoor heat exchanger exhaust coil temperature (located on the outdoor unit)
T3	Coil temperature of condenser
T4	Outdoor ambient temperature
T3B	Condenser middle temperature
T5	Refrigerant pipe inlet temperature
T6A	Economizer branch inlet temperature
T6B	Economizer branch outlet temperature
TP	Compressor discharge temperature

NOTE: T3B, T5, T6A&T6B are only for hyper heat models.

2. Main Protection

2.1 Sensor redundancy and automatic shutoff

- If one temperature sensor(T3, T4, T2B or TP) malfunctions, the unit ceases operation and displays the corresponding error code.

2.2 Automatic shutoff based on fan

If the outdoor fan speed is operating outside of the normal range, fan lack of phase or fan zero speed failure, the unit ceases operation.

2.3 Inverter module protection

The inverter module has an automatic shutoff mechanism based on the unit's current and temperature. If automatic shutoff is initiated, the corresponding error code is displayed and the unit ceases operation.

2.4 Indoor / Outdoor Units Communication Protection

If the indoor units do not receive the feedback signal from the outdoor units for 2 consecutive minutes or the outdoor units do not receive the feedback signal from any one of indoor units for 3 consecutive minutes, the unit ceases

operation. The unit displays the failure code.

2.5 EEPROM parameter error

If main chip does not receive feedback from EEPROM chip or parameter check error, the unit ceases operation.

2.6 Automatic shutoff based on compressor

If the compressor speed has been out of control, compressor lack of phase or voltage too low failure, the unit ceases operation.

2.7 Temperature Protection of Compressor Discharge

When the discharge temperature of the compressor rises, the running frequency is limited. If discharge temperature is too high, the compressor stops and then restart until discharge temperature reduced to normal range.

2.8 Evaporator Anti-Freezing Protection

The T2 sent from the indoor unit to the outdoor unit is low, and the unit limits the compressor to run at a low frequency.

2.9 Oil Return

- 1) If the unit runs at low frequency for a long time, the unit will run the oil return program to increase the frequency of the compressor;
- 2) After the unit runs continuously for a period of time, the unit will run the oil return program to increase the compressor frequency;

Outdoor Unit Disassembly

Contents

1.	Outdoor Unit Table.....	2
2.	Dimension	3
3.	Outdoor Unit Disassembly.....	6
3.1	Panel Plate.....	6
3.2	Electrical Parts	13
3.3	Fan Assembly	36
3.4	Fan Motor	37
3.5	Sound blanket.....	38
3.6	Four-way valve.....	39
3.7	Compressor.....	40

1. Outdoor Unit Disassembly

1.1 Outdoor Unit Table

Outdoor Unit Model	Panel Plate	PCB Board
A-VHP183A-1	D30	PCB board 9
A-VHP284A-1	D30	PCB board 9
A-VHP365A-1	D30	PCB board 9
A-VHP486A-1	E30	PCB board 10
A-VHP556A-1	E30	PCB board 10

2. Dimension

2.1. Panel Plate D30 (1 drive 3, 1 drive 4 & 1 drive 5)

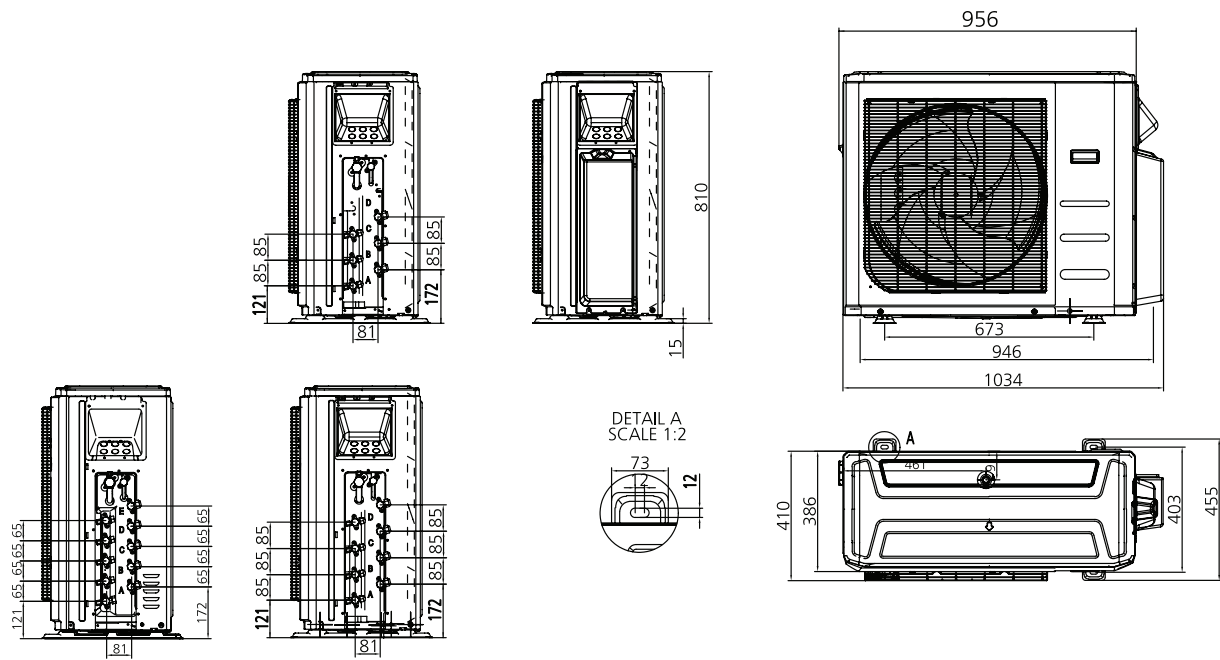

2.2. Panel Plate E30 (1 drive 4&1 drive 5)

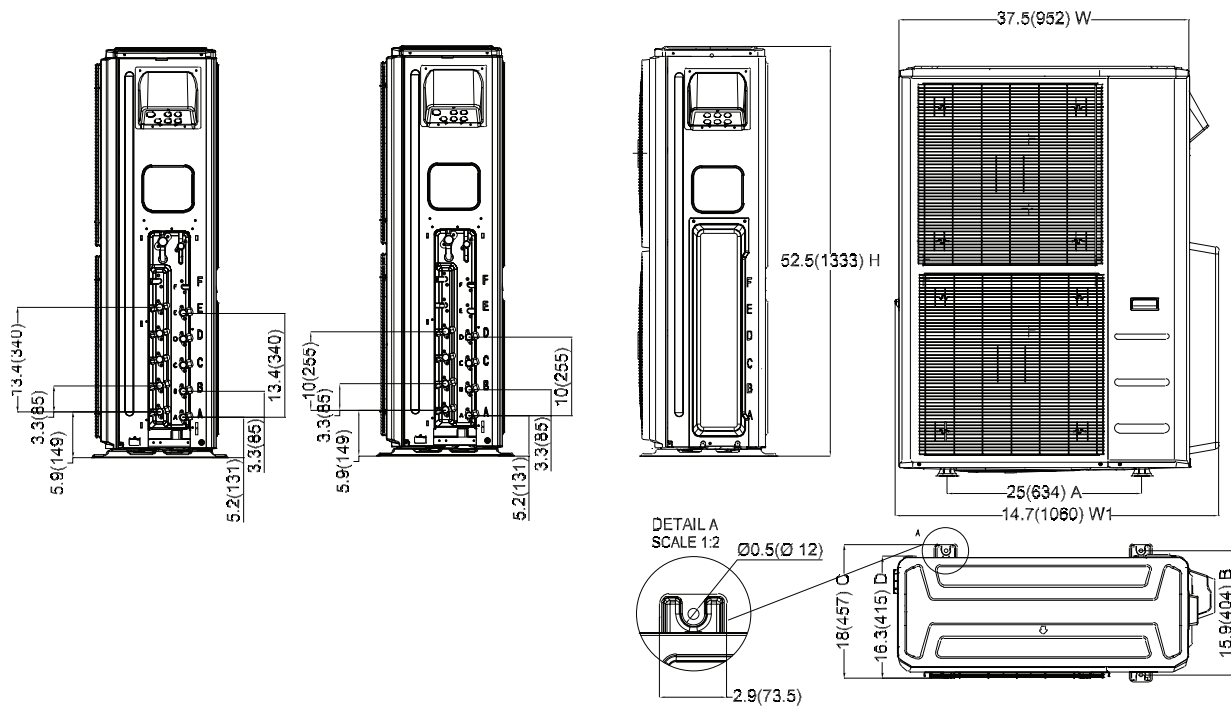

2.2. Panel Plate E30 (1 drive 6)

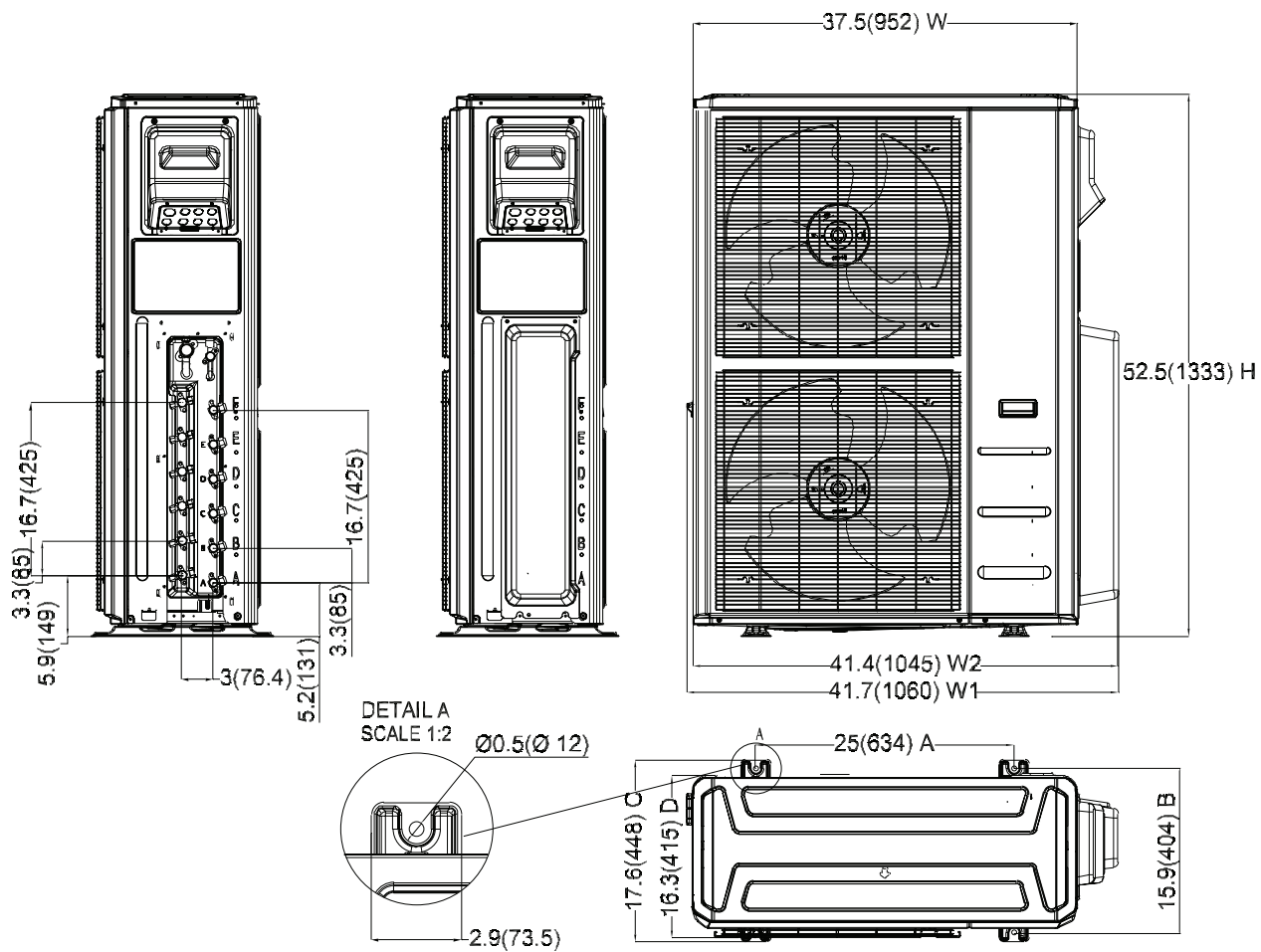

3. Outdoor Unit Disassembly

3.1 Panel Plate

3. D30

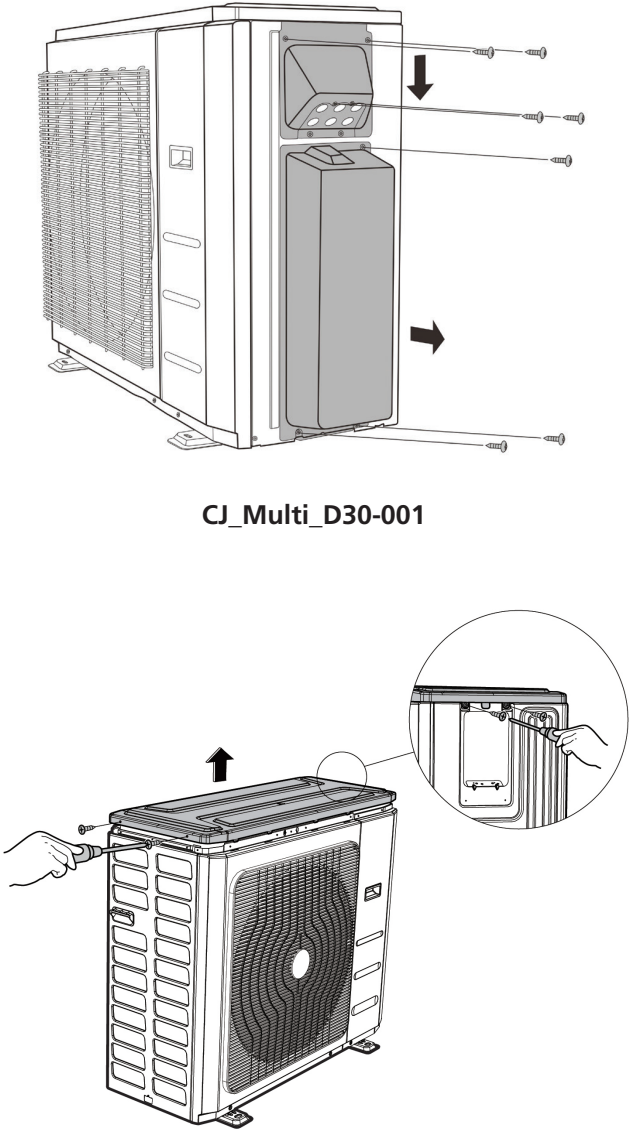
Procedure	Illustration
<p>1) Turn off the air conditioner and the power breaker.</p> <p>2) Remove four screws and then remove the big handle.</p> <p>3) Remove three screws and then remove the water collecting cover. (see CJ_Multi_D30-001).</p> <p>4) Remove the screws of the top cover and then remove the top cover (4 screws). Two of the screws is located underneath the big handle (see CJ_Multi_D30-002).</p>	 <p>The illustration is divided into two parts. The top part, labeled 'CJ_Multi_D30-001', shows a side view of the outdoor unit with a large vertical handle on the right side. Four screws are shown being removed from the handle. A downward arrow indicates the handle's removal. Below this, a horizontal arrow points to the right, indicating the next step. The bottom part, labeled 'CJ_Multi_D30-002', shows a front view of the outdoor unit with a hand using a screwdriver to remove a screw from the top cover. An upward arrow indicates the cover's removal. A circular inset provides a close-up of the handle area, showing a screw being removed from underneath it.</p> <p style="text-align: center;">CJ_Multi_D30-001</p> <p style="text-align: center;">CJ_Multi_D30-002</p>

Note: This section is for reference only. Actual unit appearance may vary.

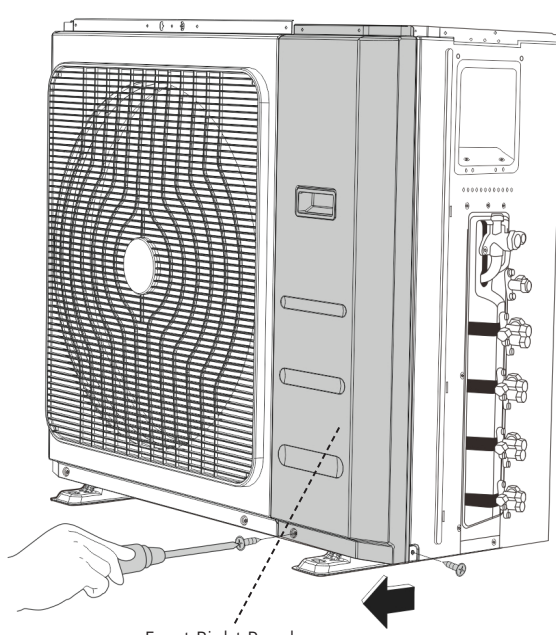
Procedure	Illustration
<p>5) Remove the screws of the front right panel and then remove the front right panel (2 screws) (see CJ_Multi_D30-003).</p>	 <p>Front Right Panel</p> <p>CJ_Multi_D30-003</p>

Note: This section is for reference only. Actual unit appearance may vary.

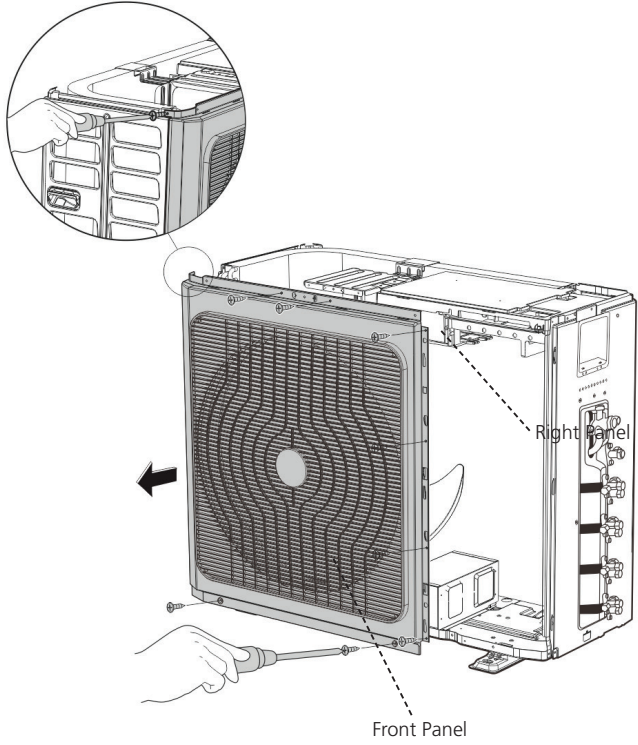
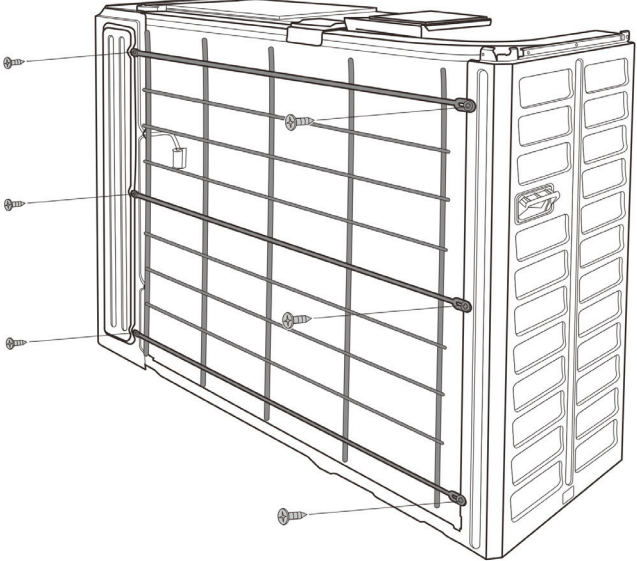
Procedure	Illustration
<p>6) Remove the screws of the front panel and then remove the front panel (9 screws) (see CJ_Multi_D30-004).</p>	 <p style="text-align: center;">CJ_Multi_D30-004</p>
<p>7) Remove the screws of the rear net and then remove the rear net (6 screws) (see CJ_Multi_D30-005). (for some models)</p>	 <p style="text-align: center;">CJ_Multi_D30-005</p>

Note: This section is for reference only. Actual unit appearance may vary.

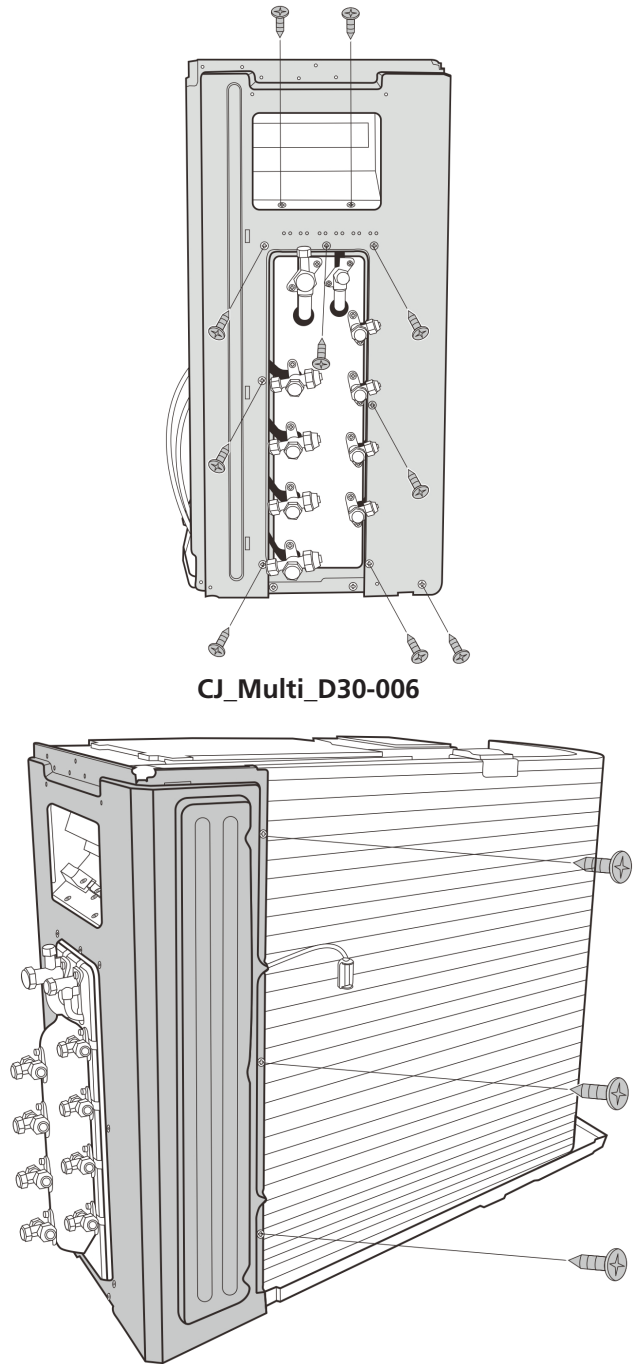
Procedure	Illustration
<p>8) Remove the screws of the right panel and then remove the right panel (12 screws) (see CJ_multi_D30-006 and CJ_Multi_D30-007).</p>	 <p style="text-align: center;">CJ_Multi_D30-006</p> <p style="text-align: center;">CJ_Multi_D30-007</p>

Note: This section is for reference only. Actual unit appearance may vary.

4. E30

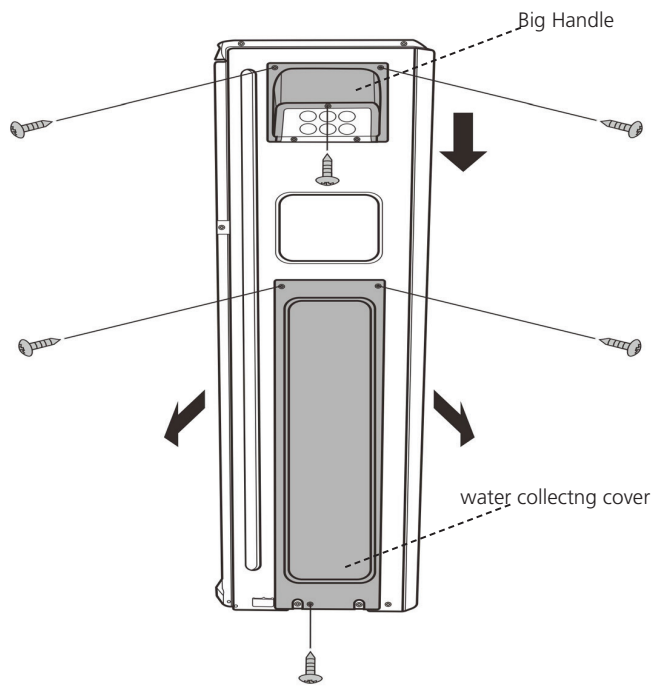
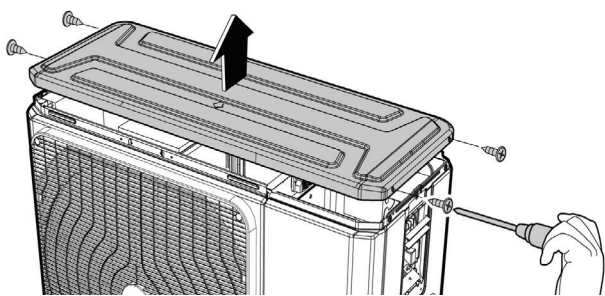
Procedure	Illustration
<ol style="list-style-type: none"> 1) Turn off the air conditioner and the power breaker. 2) Remove the screws of the big handle and then remove it.(3 screws) (see CJ_Multi_E30-001). 3) Remove the screws of the water collecting cover and then remove it.(3 screws) (see CJ_Multi_E30-001). 	 <p style="text-align: center;">CJ_Multi_E30-001</p>
<ol style="list-style-type: none"> 4) Unfix the four screws of the top cover and then remove it. (see CJ_Multi_E30-002). 	 <p style="text-align: center;">CJ_Multi_E30-002</p>

Note: This section is for reference only. Actual unit appearance may vary.

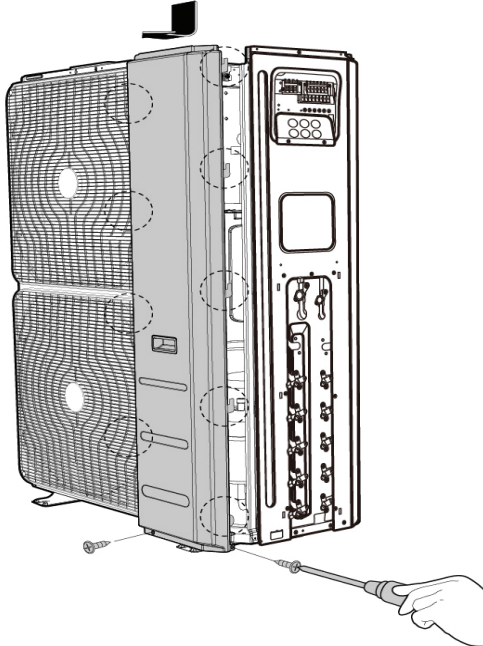
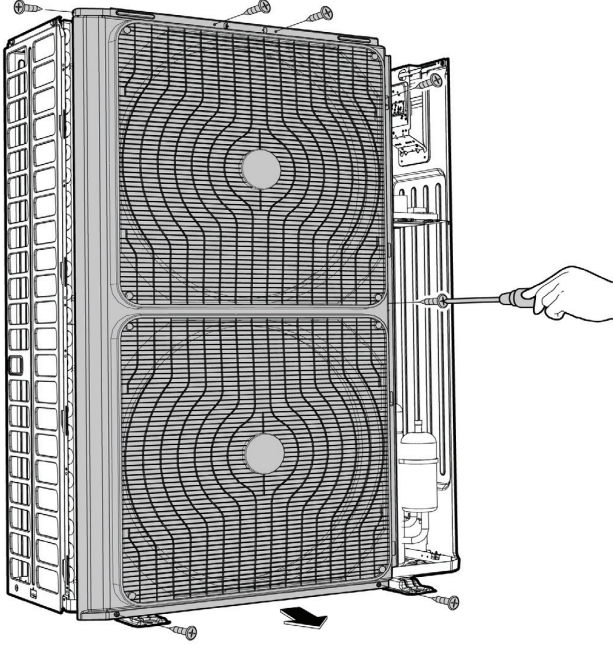
Procedure	Illustration
<p>5) Remove the two screws of the right front panel and then push it down to unhook the right front panel from the nine hooks.(see CJ_Multi_E30-003).</p>	 <p style="text-align: center;">CJ_Multi_E30-003</p>
<p>6) Remove the seven screws of the front panel and then remove the front panel (see CJ_Multi_E30-004).</p>	 <p style="text-align: center;">CJ_Multi_E30-004</p>

Note: This section is for reference only. Actual unit appearance may vary.

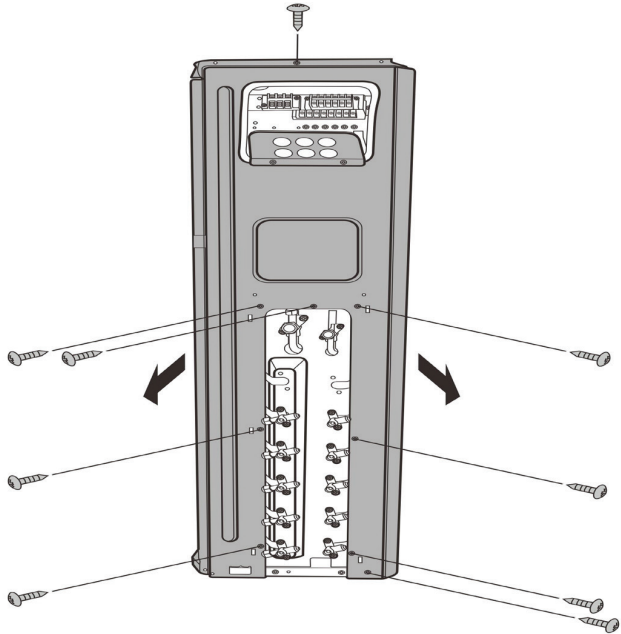
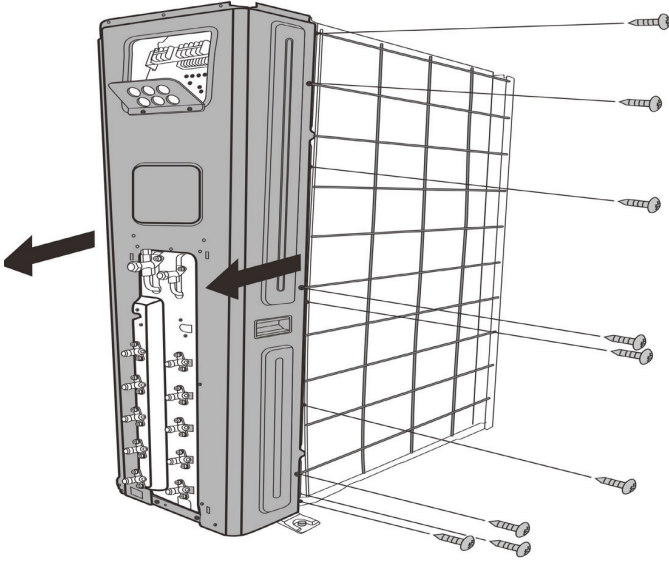
Procedure	Illustration
<p>7) Unfix the screws on the right side of the right panel.(9 screws)(see CJ_Multi_E30-005).</p>	 <p>The diagram shows a side view of the outdoor unit's right panel. Nine screws are shown being removed from the right edge of the panel. Two large black arrows point outwards from the panel, indicating its removal. The screws are labeled with lines pointing to their locations on the panel.</p> <p style="text-align: center;">CJ_Multi_E30-005</p>
<p>8) Remove the screws on the back of the right panel and then remove the right panel and rear net.(9 screws).(see CJ_Multi_E30-006).</p>	 <p>The diagram shows the outdoor unit with the right panel and rear net removed. Nine screws are shown being removed from the back of the right panel. Two large black arrows point outwards from the panel, indicating its removal. The screws are labeled with lines pointing to their locations on the back of the panel.</p> <p style="text-align: center;">CJ_Multi_E30-006</p>

Note: This section is for reference only. Actual unit appearance may vary.

3.2 Electrical parts

⚠ WARNING: Antistatic gloves must be worn when you disassemble the electronic box.

Note: Remove the air outlet grille(refer to 1.1 Panel Plate) before disassembling electrical parts.

PCB Board 1

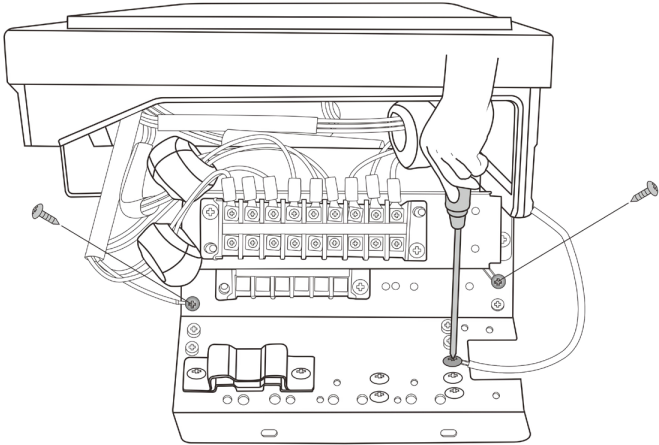
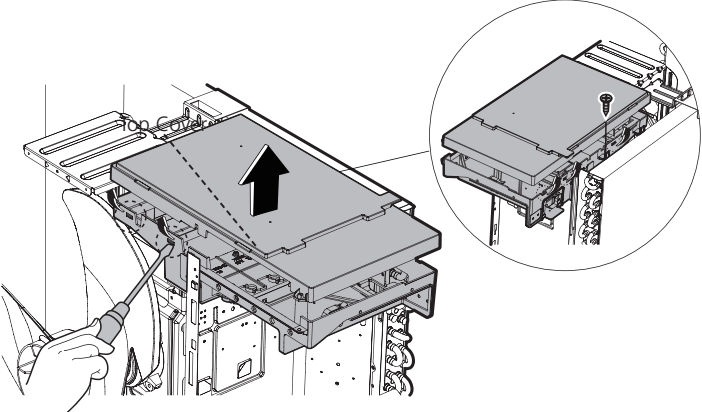
Procedure	Illustration
<p>1) Remove the screws of the ground wirings. (3 screws) (CJ_Multi-PCB_001-1).</p>	 <p style="text-align: center;">CJ_Multi-PCB_001-1</p>
<p>2) Unfix the hooks and screw and then open the electronic control box cover (5 hooks and 1 screw)(see CJ_Multi-PCB_001-2).</p>	 <p style="text-align: center;">CJ_Multi-PCB_001-2</p>

Note: This section is for reference only. Actual unit appearance may vary.

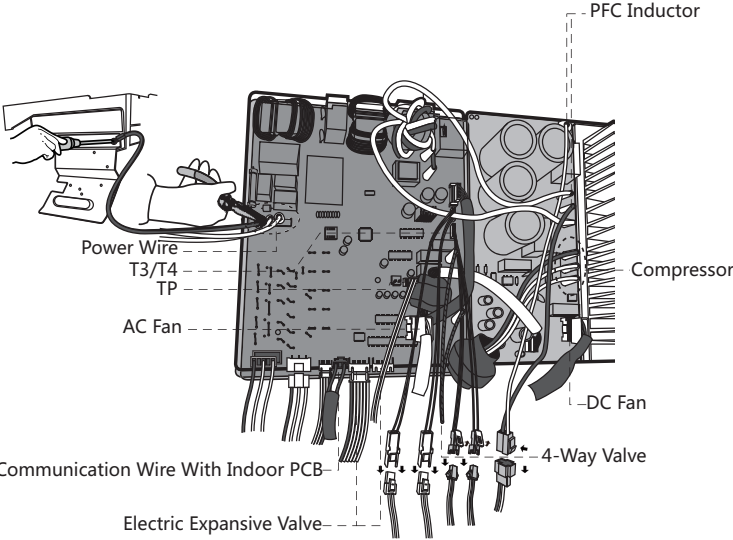
Procedure	Illustration
<ol style="list-style-type: none"> 3) Disconnect the connector for outdoor DC fan from the electronic control board (see CJ_Multi-PCB_001-3). 4) Remove the connector for the compressor (see CJ_Multi-PCB_001-3). 5) Pull out the two blue wires connected with the four way valve (see CJ_Multi-PCB_001-3). 6) Pull out connectors of the condenser coil temp. sensor(T3),outdoor ambient temp. sensor(T4) and discharge temp. sensor(TP) (see CJ_Multi-PCB_001-3). 7) Disconnect the electronic expansion valve wire (see CJ_Multi-PCB_001-3). 8) Disconnect the communication wire indoor PCB (see CJ_Multi-PCB_001-3). 9) Disconnect the PFC inductor (see CJ_Multi-PCB_001-3). 10)Then remove the electronic control box (see CJ_Multi-PCB_001-3). 	 <p style="text-align: center;">CJ_Multi-PCB_001-3</p>

Note: This section is for reference only. Actual unit appearance may vary.

PCB Board 2

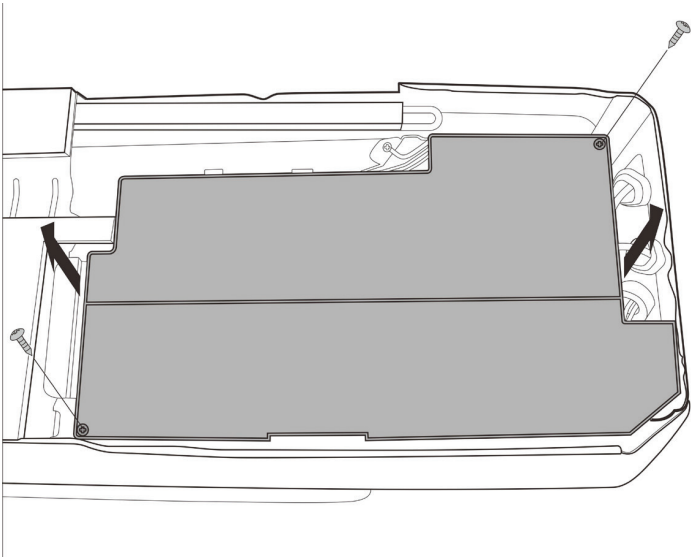
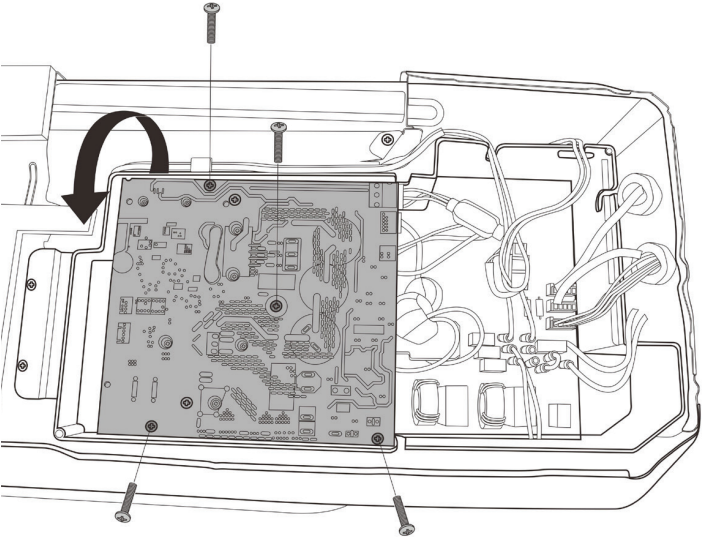
Procedure	Illustration
<p>1) Remove the screws of the top cover. (2 screws) (CJ_Multi-PCB_002-1).</p>	 <p style="text-align: center;">CJ_Multi-PCB_002-1</p>
<p>2) Unfix the screws and then turn over the IPM board (4 screws) (see CJ_Multi-PCB_002-2).</p>	 <p style="text-align: center;">CJ_Multi-PCB_002-2</p>

Note: This section is for reference only. Actual unit appearance may vary.

Procedure	Illustration
<ol style="list-style-type: none"> 3) Disconnect the connector for outdoor DC fan from the electronic control board (see CJ_Multi-PCB_002-3). 4) Remove the connector for the compressor (see CJ_Multi-PCB_002-4). 5) Pull out the two blue wires connected with the four way valve (see CJ_Multi-PCB_002-4). 6) Pull out connectors of the condenser coil temp. sensor(T3),outdoor ambient temp. sensor(T4) and discharge temp. sensor(TP) (see CJ_Multi-PCB_002-4). 7) Disconnect the electronic expansion valve wire (see CJ_Multi-PCB_002-4). 8) Disconnect the communication wire indoor PCB (see CJ_Multi-PCB_002-4). 9) Disconnect the PFC inductor (see CJ_Multi-PCB_002-4). 10)Then remove the electronic control box (see CJ_Multi-PCB_002-4). 	<p style="text-align: center;">CJ_Multi-PCB_002-3</p> <p style="text-align: center;">CJ_Multi-PCB_002-4</p>

Note: This section is for reference only. Actual unit appearance may vary.

PCB board 3

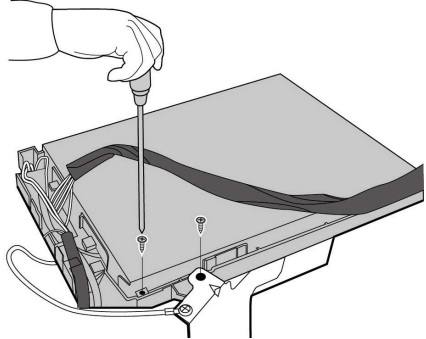
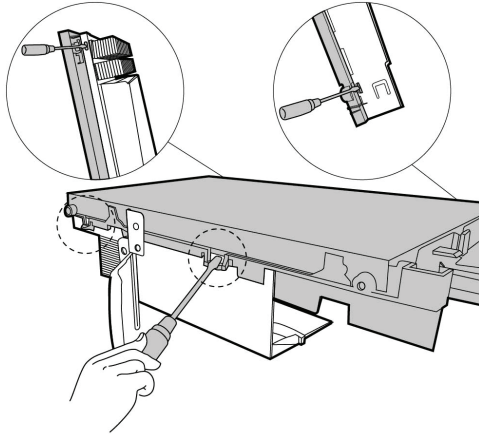
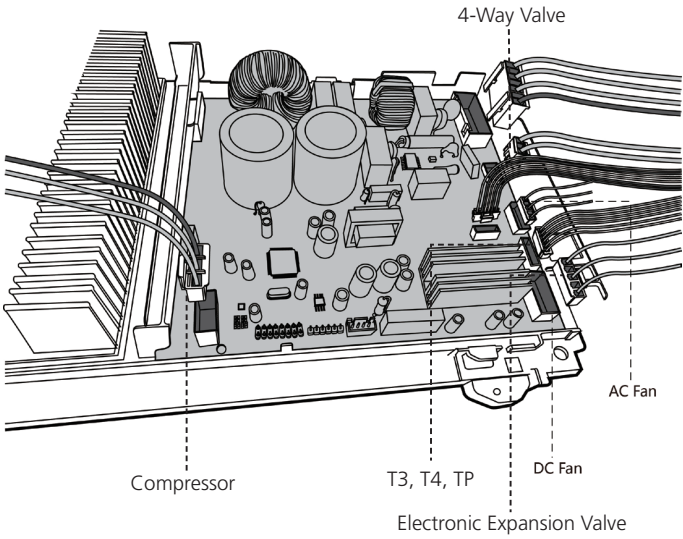
Procedure	Illustration
<p>1) Remove the screws of the top cover. (2 screws) (see CJ_Multi-PCB_003-1).</p>	 <p style="text-align: center;">CJ_Multi-PCB_003-1</p>
<p>2) Unfix the hooks and then open the electronic control box cover (4 hooks) (see CJ_Multi-PCB_003-2).</p>	 <p style="text-align: center;">CJ_Multi-PCB_003-2</p>
<p>3) Disconnect the connector for fan motor from the electronic control board (see CJ_Multi-PCB_003-3).</p> <p>4) Remove the connector for the compressor (see CJ_Multi-PCB_003-3).</p> <p>5) Pull out the two blue wires connected with the four way valve (CJ_Multi-PCB_003-3).</p> <p>6) Pull out connectors of the condenser coil temp. sensor(T3), outdoor ambient temp. sensor(T4) and discharge temp. sensor(TP) (CJ_Multi-PCB_003-3).</p> <p>7) Disconnect the electronic expansion valve wire (CJ_Multi-PCB_003-3).</p> <p>8) Then remove the electronic control board.</p>	 <p style="text-align: center;">CJ_Multi-PCB_003-3</p>

Note: This section is for reference only. Actual unit appearance may vary.

PCB board 3

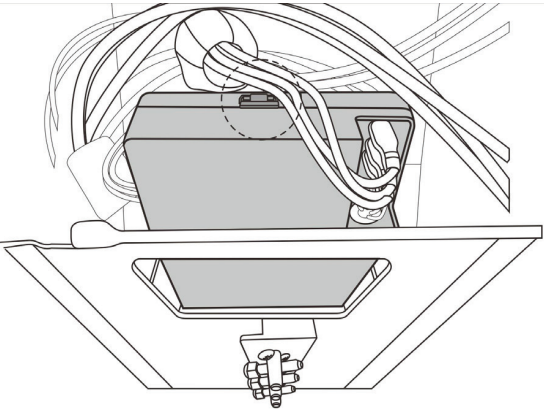
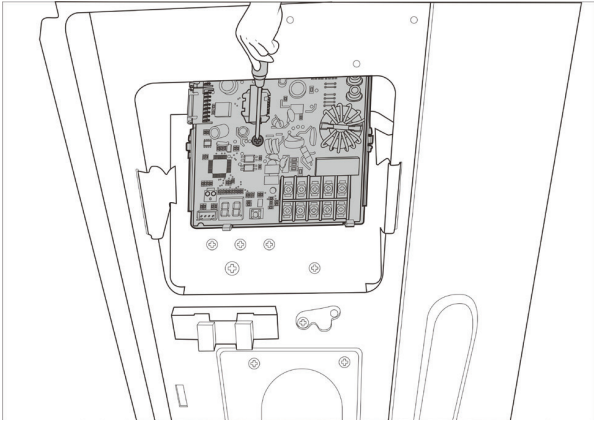
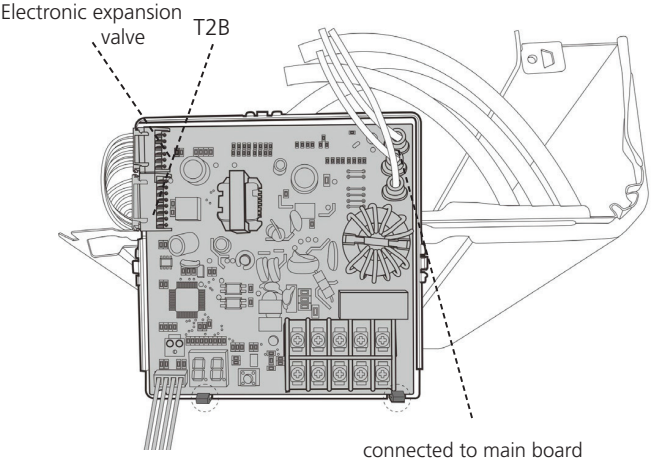
Procedure	Illustration
<p>1) Unfix the hooks and then remove the electronic installing box . (2 screws) (see CJ_Multi_PCB_003-4) .</p>	 <p style="text-align: center;">CJ_Multi-PCB_003-4</p>
<p>2) Remove one screw of module board. (see CJ_Multi_PCB_003-5).</p>	 <p style="text-align: center;">CJ_Multi-PCB_003-5</p>
<p>3) Disconnect the connectors of the module board. (see CJ_Multi_PCB_003-6).</p>	 <p style="text-align: center;">CJ_Multi-PCB_003-6</p>

Note: This section is for reference only. Actual unit appearance may vary.

PCB board 4

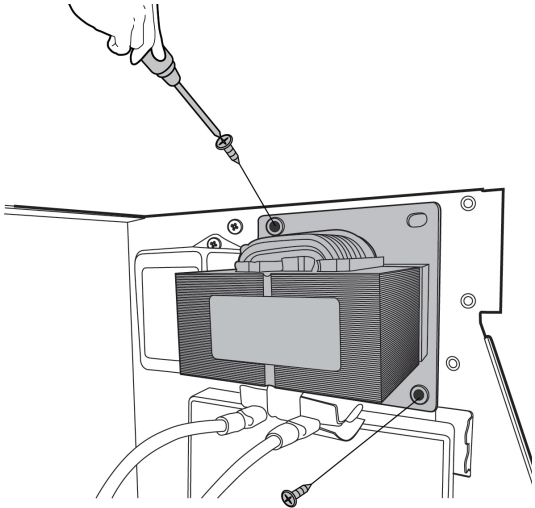
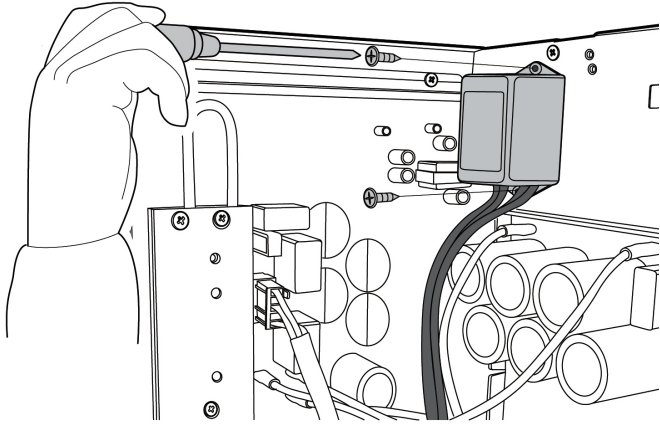
Procedure	Illustration
<p>1) Remove the screws and then remove the reactor 1. (2 screws) (see CJ_Multi_PCB_004-1).</p>	 <p style="text-align: center;">CJ_Multi-PCB_004-1</p>
<p>2) Remove the screws and then remove the reactor 2 (see CJ_Multi_PCB_004-2).</p>	 <p style="text-align: center;">CJ_Multi-PCB_004-2</p>

Note: This section is for reference only. Actual unit appearance may vary.

PCB board 4

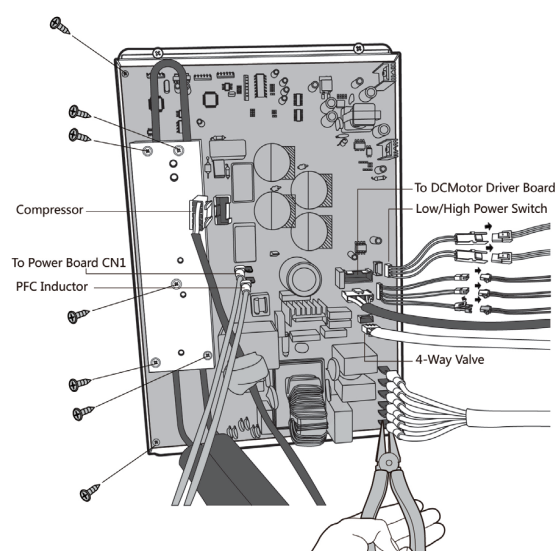
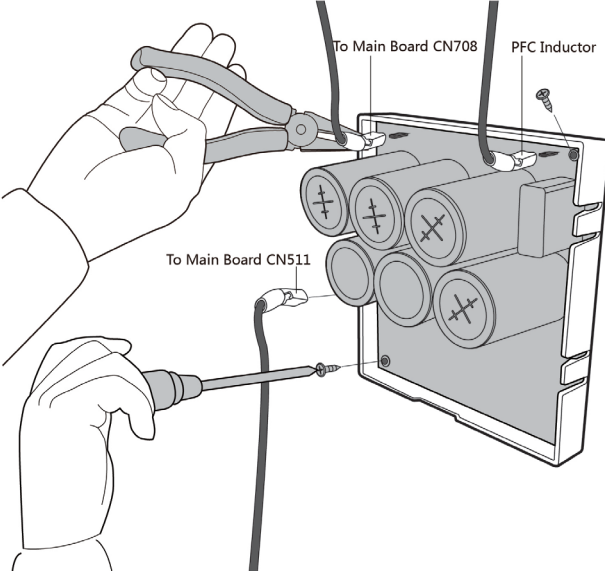
Procedure	Illustration
<ol style="list-style-type: none"> 1) Unfix five screws and then remove the radiating pipe. (see CJ_Multi_PCB_004-3). 2) Unfix two screws on the main board (see CJ_Multi_PCB_004-3). 3) Disconnect the connectors on the main board.(see CJ_Multi_PCB_004-3). 	 <p style="text-align: center;">CJ_Multi-PCB_004-3</p>
<ol style="list-style-type: none"> 4) Unfix two screws on the upper board (see CJ_Multi_PCB_004-4). 5) Remove the connectors on the upper board (see CJ_Multi_PCB_004-4). 	 <p style="text-align: center;">CJ_Multi-PCB_004-4</p>

Note: This section is for reference only. Actual unit appearance may vary.

PCB board 4

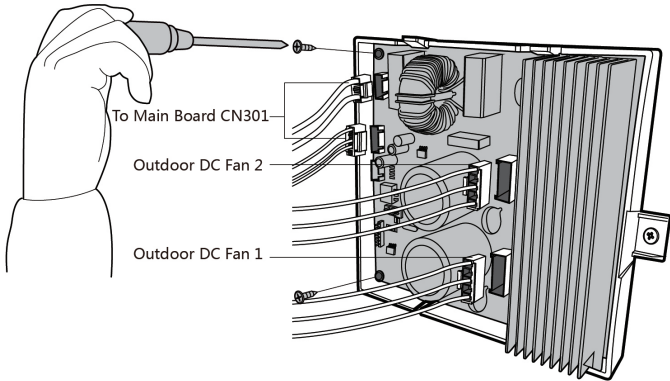
Procedure	Illustration
<p>1) Unfix two screws on the bottom board. (see CJ_Multi_PCB_004-5).</p> <p>2) Disconnect the connectors on the bottom board (see CJ_Multi_PCB_004-5).</p>	 <p style="text-align: center;">CJ_Multi-PCB_004-5</p>

Note: This section is for reference only. Actual unit appearance may vary.

PCB board 5

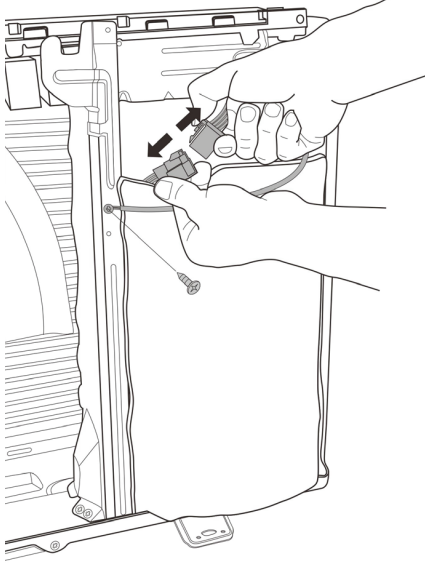
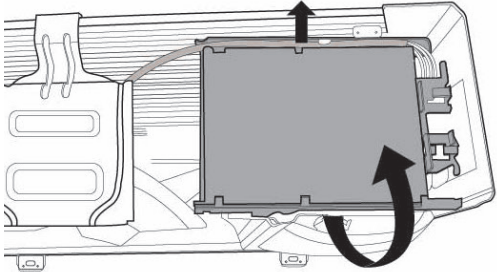
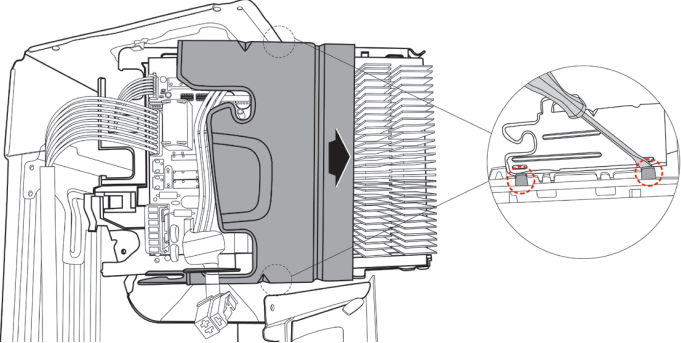
Procedure	Illustration
<p>1) Disconnect the connector for compressor and release the ground wire(1 screw). (see CJ_ODU_Multi_PCB_005-1).</p> <p>2) Pull out the wires from electrical supporting plate and turn over the electronic control assembly. (see CJ_ODU_Multi_PCB_005-2).</p> <p>3) Remove the electronic installing box subassembly (4 hooks) (see CJ_ODU_Multi_PCB_005-3).</p>	 <p style="text-align: center;">CJ_ODU_Multi_PCB_005-1</p>  <p style="text-align: center;">CJ_ODU_Multi_PCB_005-2</p>  <p style="text-align: center;">CJ_ODU_Multi_PCB_005-3</p>

Note: This section is for reference only. Actual unit appearance may vary.

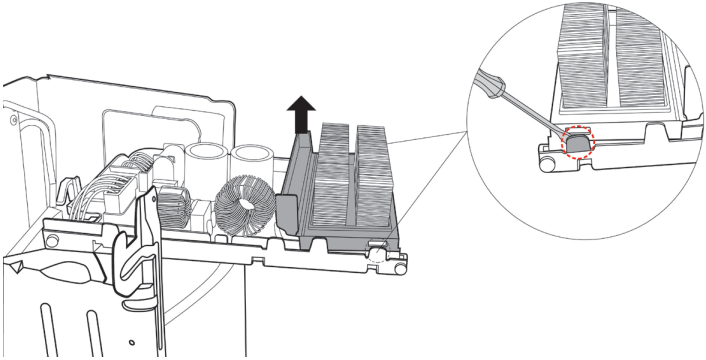
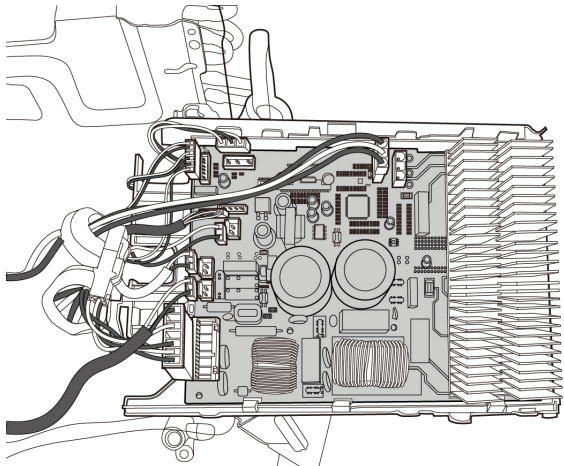
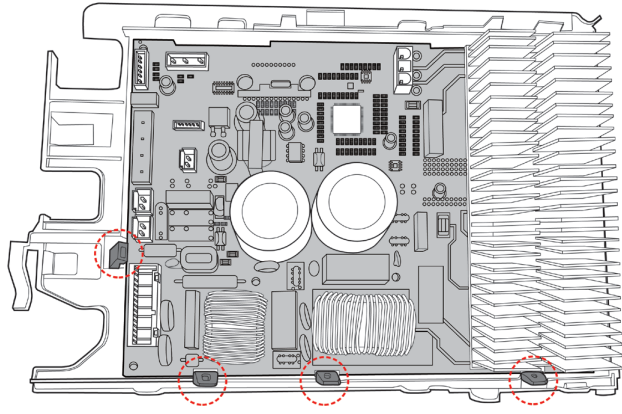
Procedure	Illustration
<p>4) Remove the fixing board (2 hooks) (see CJ_ODU_Multi_PCB_005-4).</p>	 <p style="text-align: center;">CJ_ODU_Multi_PCB_005-4</p>
<p>5) Disconnect the connectors from the electronic control board (see CJ_ODU_Multi_PCB_005-5).</p>	 <p style="text-align: center;">CJ_ODU_Multi_PCB_005-5</p>
<p>6) Then remove the electronic control board (4 hooks).(see CJ_ODU_Multi_PCB_005-6).</p>	 <p style="text-align: center;">CJ_ODU_Multi_PCB_005-6</p>

Note: This section is for reference only. Actual unit appearance may vary.

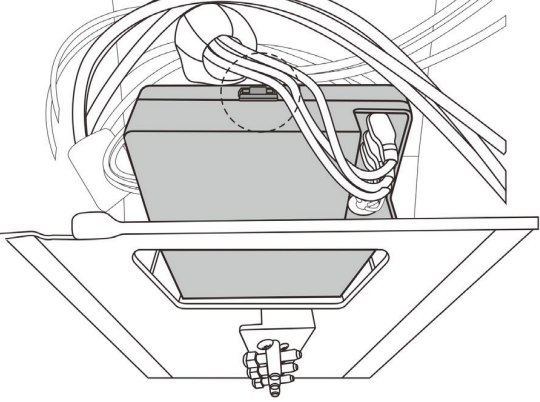
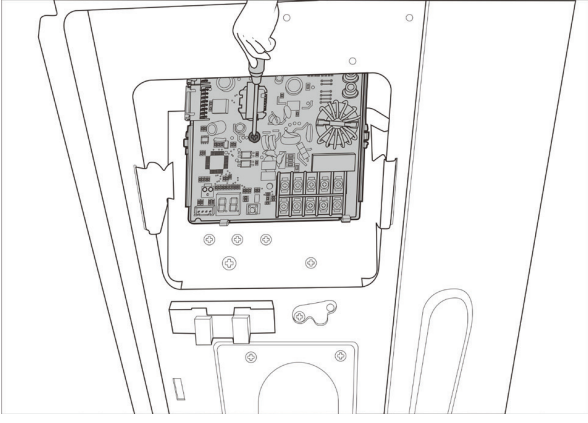
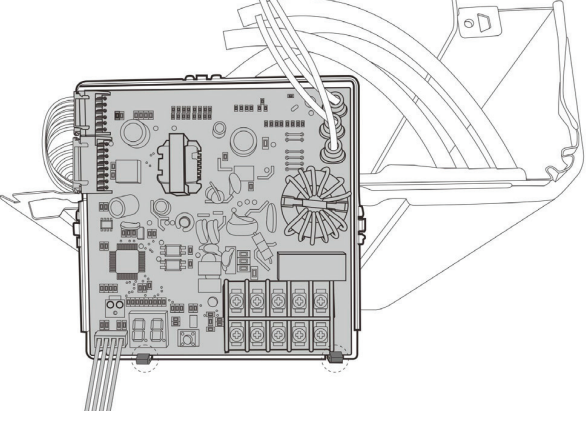
Procedure	Illustration
7) Unfix the hooks and then remove the electronic installing box . (2 screws) (see CJ_Multi_PCB_005-7) .	 <p style="text-align: center;">CJ_Multi-PCB_005-7</p>
8) Remove one screw of module board. (see CJ_Multi_PCB_005-8).	 <p style="text-align: center;">CJ_Multi-PCB_005-8</p>
9) Disconnect the connectors of the module board. (see CJ_Multi_PCB_005-9).	 <p style="text-align: center;">CJ_Multi-PCB_005-9</p>

Note: This section is for reference only. Actual unit appearance may vary.

PCB board 6

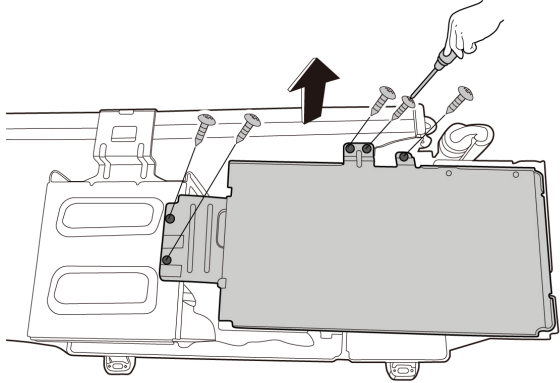
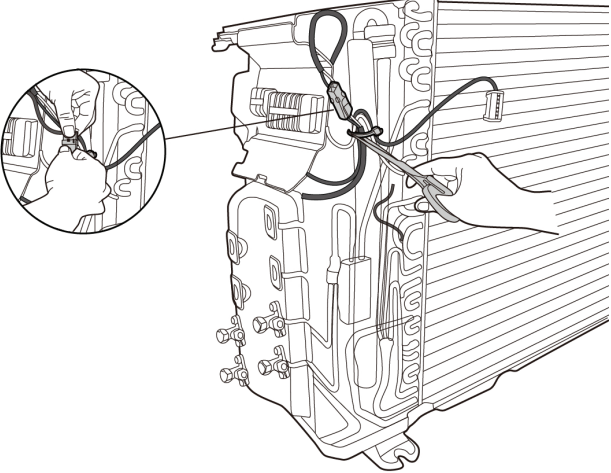
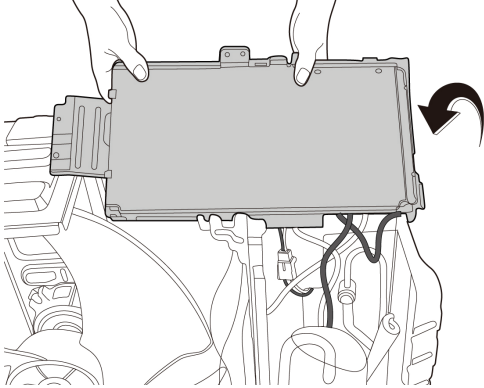
Procedure	Illustration
<p>1) Remove 5 screws of electrical control box cover and remove it. (see CJ_ODU_Multi_PCB_006-1).</p>	 <p style="text-align: center;">CJ_ODU_Multi_PCB_006-1</p>
<p>2) Cut the ribbon by a shear and disconnect the 4-way valve connector. (see CJ_ODU_Multi_PCB_006-2).</p>	 <p style="text-align: center;">CJ_ODU_Multi_PCB_006-2</p>
<p>3) Turn over the electronic control box subassembly. (see CJ_ODU_Multi_PCB_006-3).</p>	 <p style="text-align: center;">CJ_ODU_Multi_PCB_006-3</p>

Note: This section is for reference only. Actual unit appearance may vary.

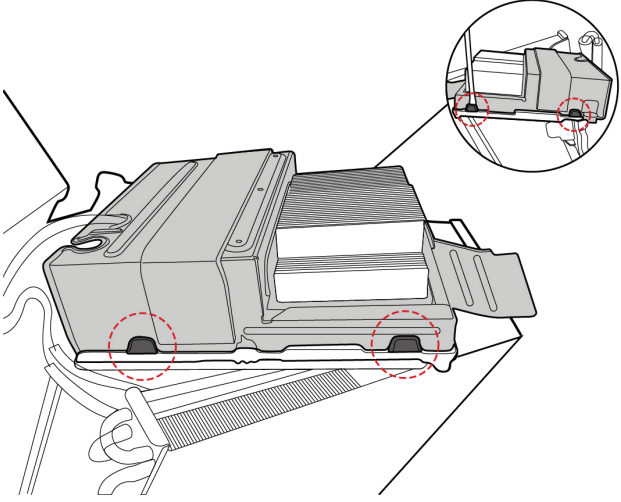
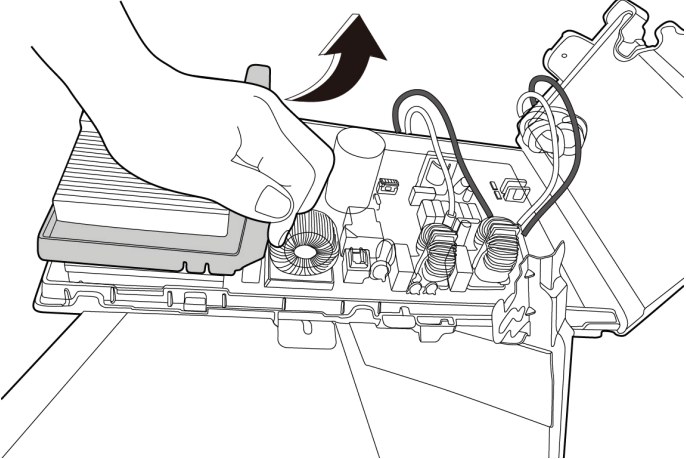
Procedure	Illustration
<p>4) Remove the electronic installing box subassembly (4 hooks) (see CJ_ODU_Multi_PCB_006-4).</p>	 <p style="text-align: center;">CJ_ODU_Multi_PCB_006-4</p>
<p>5) Remove the support of electronic control box.(see CJ_ODU_Multi_PCB_006-5).</p>	 <p style="text-align: center;">CJ_ODU_Multi_PCB_006-5</p>

Note: This section is for reference only. Actual unit appearance may vary.

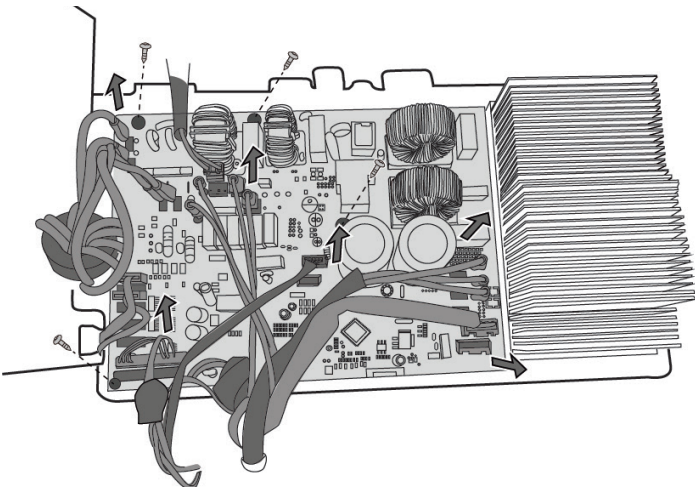
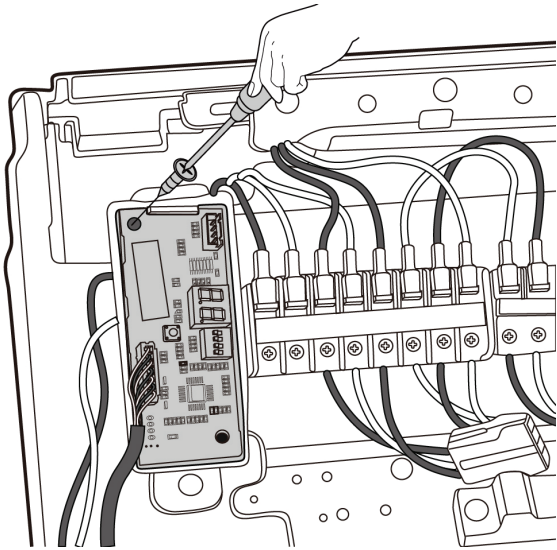
Procedure	Illustration
<p>6) Disconnect the connectors from the electronic control board (see CJ_ODU_Multi_PCB_006-6).</p> <p>7) Remove 4 screws and then remove the electronic control board.(see CJ_ODU_Multi_PCB_006-6).</p>	 <p style="text-align: center;">CJ_ODU_Multi_PCB_006-6</p>
<p>8) Pull out the connector, remove one screw and then remove the key board subassembly on terminal board. (see CJ_Multi_PCB_006-7).</p>	 <p style="text-align: center;">CJ_Multi-PCB_006-7</p>

Note: This section is for reference only. Actual unit appearance may vary.

PCB board 7

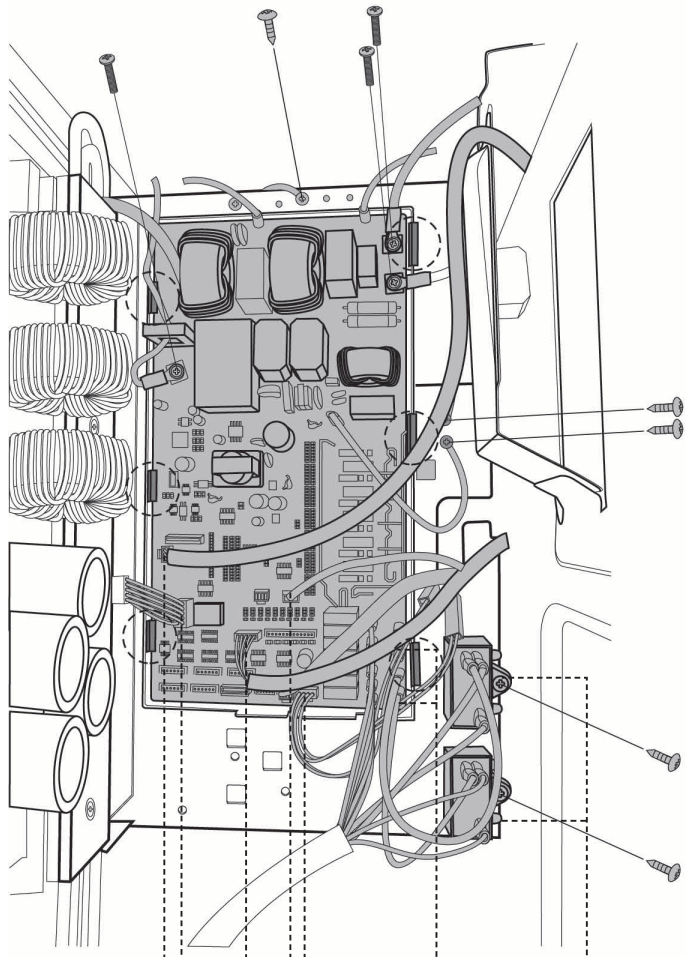
Procedure	Illustration
<ol style="list-style-type: none"> 1) Remove 2 screws to disconnect the power supply wires. (see CJ_ODU_Multi_PCB_007-1) 2) Remove 3 screws to disconnect ground wires. (see CJ_ODU_Multi_PCB_007-1) 3) Disconnect the wires connected to main control board. (see CJ_ODU_Multi_PCB_007-1) 4) Disconnect the wires between main control board and IPM module board. (see CJ_ODU_Multi_PCB_007-1) 5) Remove the 4 screws and unfix the 6 hooks and then remove the main control board.(see CJ_ODU_Multi_PCB_007-1) 6) Remove 1 screw to remove the fan motor capacitor(1 screw for each capacitor).(see CJ_ODU_Multi_PCB_007-1). 	 <p style="text-align: center;">CJ_ODU_Multi_PCB_007-1</p>

Note: This section is for reference only. Actual unit appearance may vary.

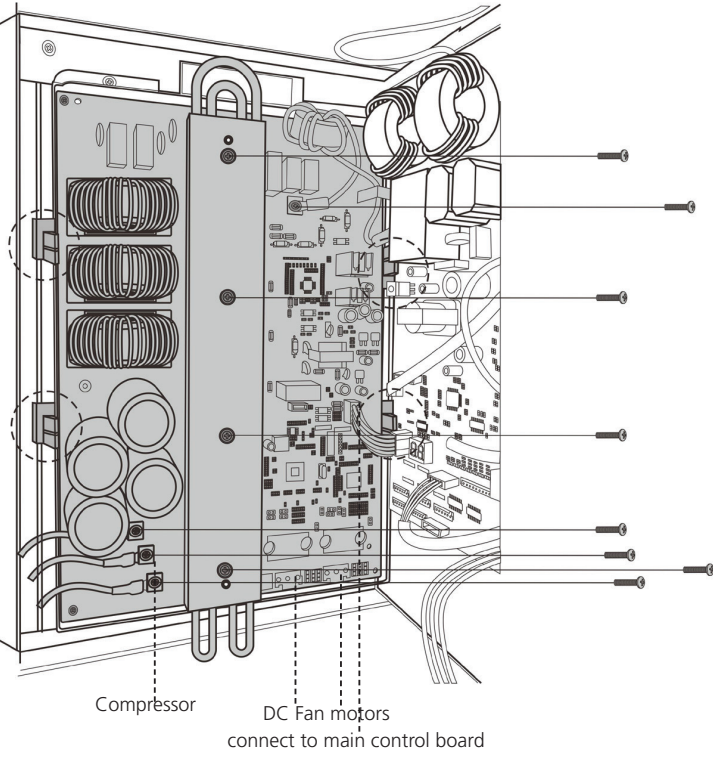
Procedure	Illustration
<ol style="list-style-type: none"> 1) Remove 2 screws to disconnect the power supply wires. (see CJ_ODU_Multi_PCB_007-2) 2) Remove 3 screws to disconnect the wires connected to the compressor. (see CJ_ODU_Multi_PCB_007-2) 3) Remove 3 screws to remove the radiator. (see CJ_ODU_Multi_PCB_007-2) 4) Disconnect the wires between IPM module board and main control board. (see CJ_ODU_Multi_PCB_007-2) 5) Remove the 4 screws and unfix the 4 hooks and then remove the IPM module board. (see CJ_ODU_Multi_PCB_007-2) 	 <p style="text-align: center;">Compressor</p> <p style="text-align: center;">DC Fan motors connect to main control board</p> <p style="text-align: center;">CJ_ODU_Multi_PCB_007-2</p>

Note: This section is for reference only. Actual unit appearance may vary.

PCB board 8

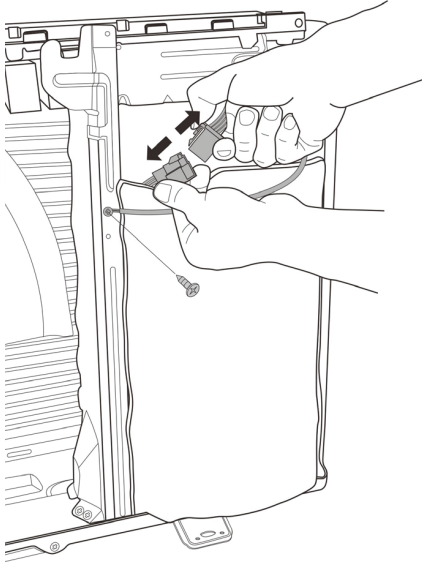
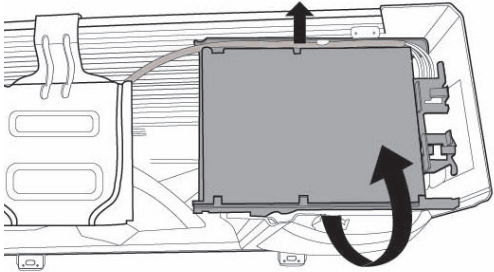
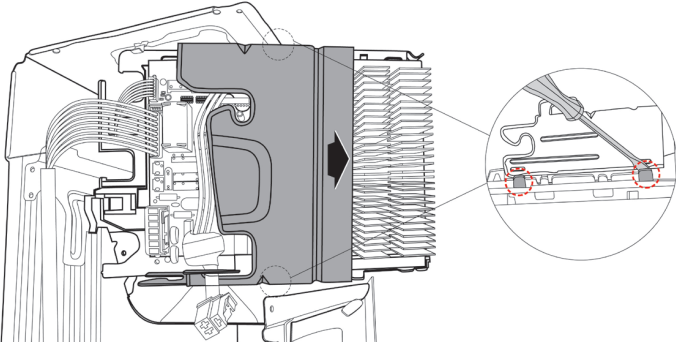
Procedure	Illustration
<p>1) Disconnect the connector for compressor and release the ground wire(1 screw). (see CJ_ODU_Multi_PCB_008-1).</p> <p>2) Pull out the wires from electrical supporting plate and turn over the electronic control assembly. (see CJ_ODU_Multi_PCB_008-2).</p> <p>3) Remove the electronic installing box subassembly (4 hooks) (see CJ_ODU_Multi_PCB_008-3).</p>	 <p style="text-align: center;">CJ_ODU_Multi_PCB_008-1</p>  <p style="text-align: center;">CJ_ODU_Multi_PCB_008-2</p>  <p style="text-align: center;">CJ_ODU_Multi_PCB_008-3</p>

Note: This section is for reference only. Actual unit appearance may vary.

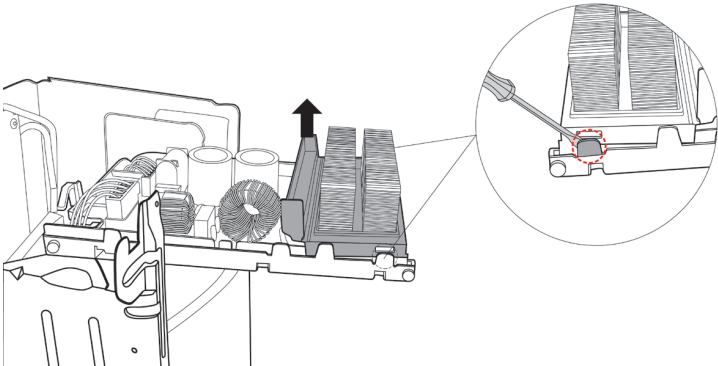
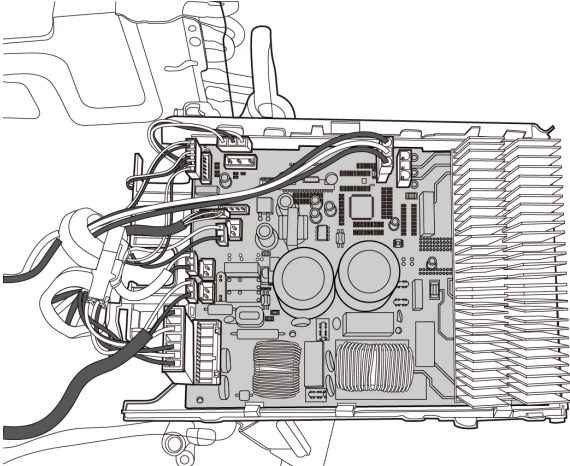
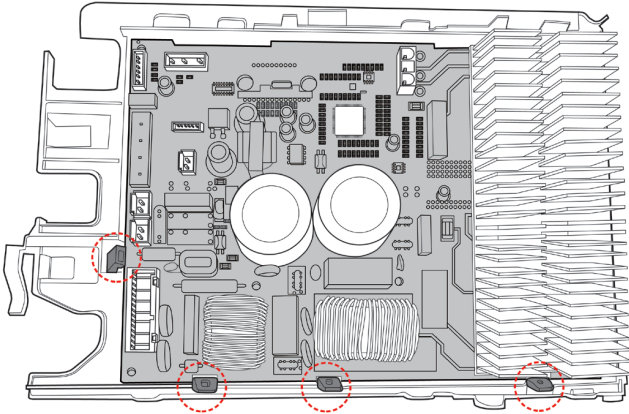
Procedure	Illustration
<p>4) Remove the fixing board (2 hooks) (see CJ_ODU_Multi_PCB_008-4).</p>	 <p style="text-align: center;">CJ_ODU_Multi_PCB_008-4</p>
<p>5) Disconnect the connectors from the electronic control board (see CJ_ODU_Multi_PCB_008-5).</p>	 <p style="text-align: center;">CJ_ODU_Multi_PCB_008-5</p>
<p>6) Then remove the electronic control board (4 hooks).(see CJ_ODU_Multi_PCB_008-6).</p>	 <p style="text-align: center;">CJ_ODU_Multi_PCB_008-6</p>

Note: This section is for reference only. Actual unit appearance may vary.

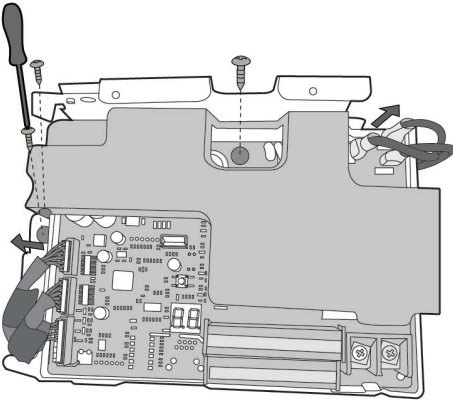
Procedure	Illustration
<p>7) Remove 3 screws and then remove the cover of electronic installing box. (see CJ_Multi_PCB_008-7) .</p> <p>8) Disconnect the connectors of the module board and then remove the module board. (see CJ_Multi_PCB_008-7).</p>	 <p data-bbox="889 703 1140 735">CJ_Multi-PCB_008-7</p>

Note: This section is for reference only. Actual unit appearance may vary.

PCB board 9

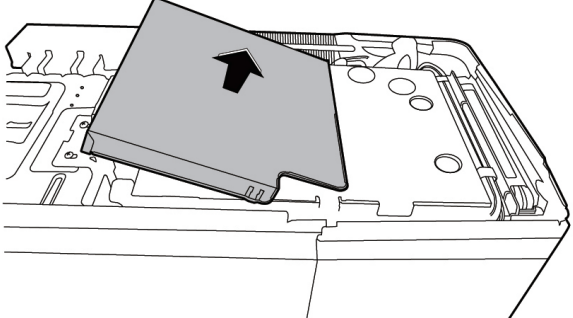
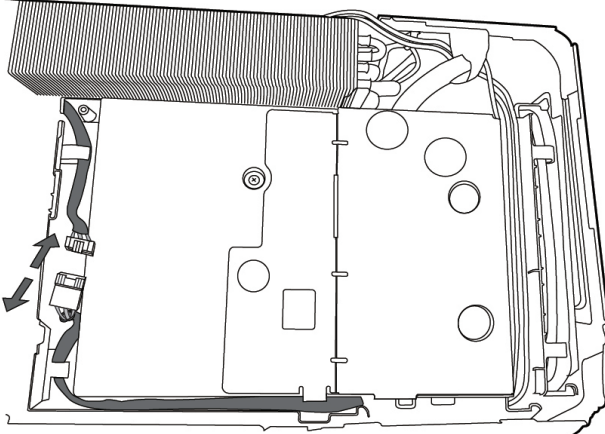
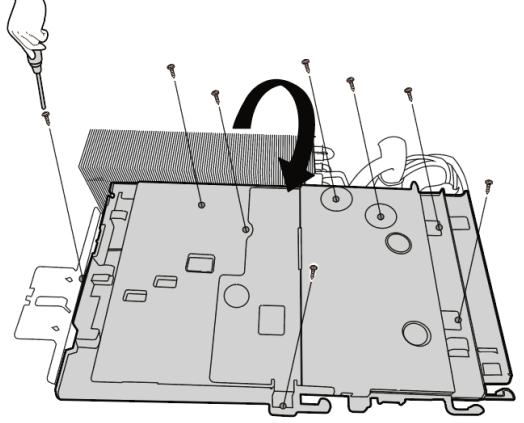
Procedure	Illustration
<p>1) Remove the cover of electrical control box. (see CJ_ODU_Multi_PCB_009-1).</p>	 <p style="text-align: center;">CJ_ODU_Multi_PCB_009-1</p>
<p>2) Disconnect the fan motor connector. (see CJ_ODU_Multi_PCB_009-2).</p>	 <p style="text-align: center;">CJ_ODU_Multi_PCB_009-2</p>
<p>3) Remove eight fixing screws.</p> <p>4) Turn over the electronic control box subassembly. (see CJ_ODU_Multi_PCB_009-3).</p>	 <p style="text-align: center;">CJ_ODU_Multi_PCB_009-3</p>

Note: This section is for reference only. Actual unit appearance may vary.

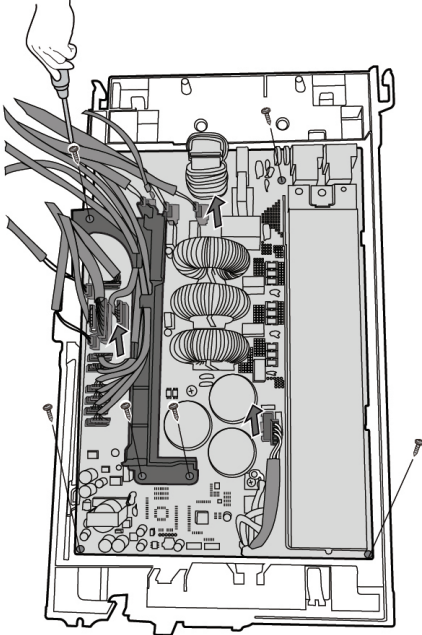
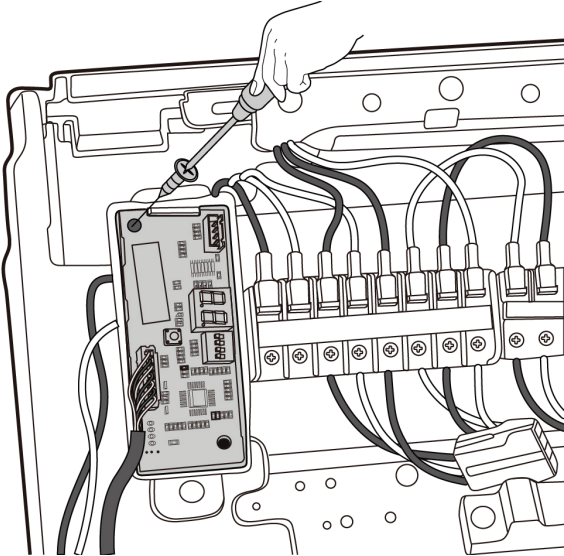
Procedure	Illustration
<p>5) Remove 3 screws and then remove the bracket. (see CJ_ODU_Multi_PCB_009-4).</p> <p>6) Disconnect the connectors from the electronic control board (see CJ_ODU_Multi_PCB_009-4).</p> <p>7) Remove 3 screws and then remove the electronic control board.(see CJ_ODU_Multi_PCB_009-4).</p>	 <p data-bbox="850 890 1179 919">CJ_ODU_Multi_PCB_009-4</p>
<p>8) Pull out the connector, remove one screw and then remove the key board subassembly on terminal board. (see CJ_Multi_PCB_009-5).</p>	 <p data-bbox="850 1577 1179 1606">CJ_ODU_Multi_PCB_009-5</p>

Note: This section is for reference only. Actual unit appearance may vary.

PCB board 10

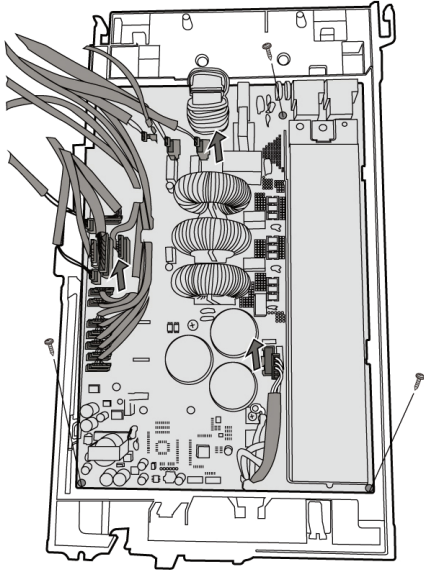
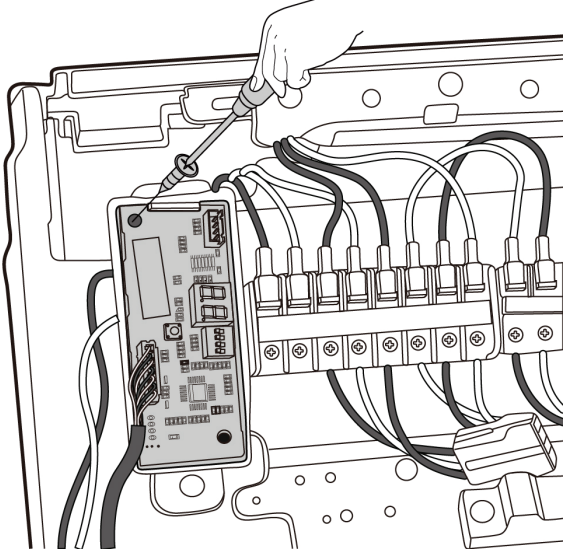
Procedure	Illustration
<p>9) Disconnect the connectors from the electronic control board (see CJ_ODU_Multi_PCB_010-1).</p> <p>10) Remove 3 screws and then remove the electronic control board.(see CJ_ODU_Multi_PCB_010-1).</p>	 <p style="text-align: center;">CJ_ODU_Multi_PCB_010-1</p>
<p>11) Pull out the connector, remove one screw and then remove the key board subassembly on terminal board. (see CJ_Multi_PCB_010-2).</p>	 <p style="text-align: center;">CJ_ODU_Multi_PCB_010-2</p>

Note: This section is for reference only. Actual unit appearance may vary.

3.3 Fan Assembly

Note: Remove the panel plate (refer to 1.1 Panel Plate) before disassembling fan.

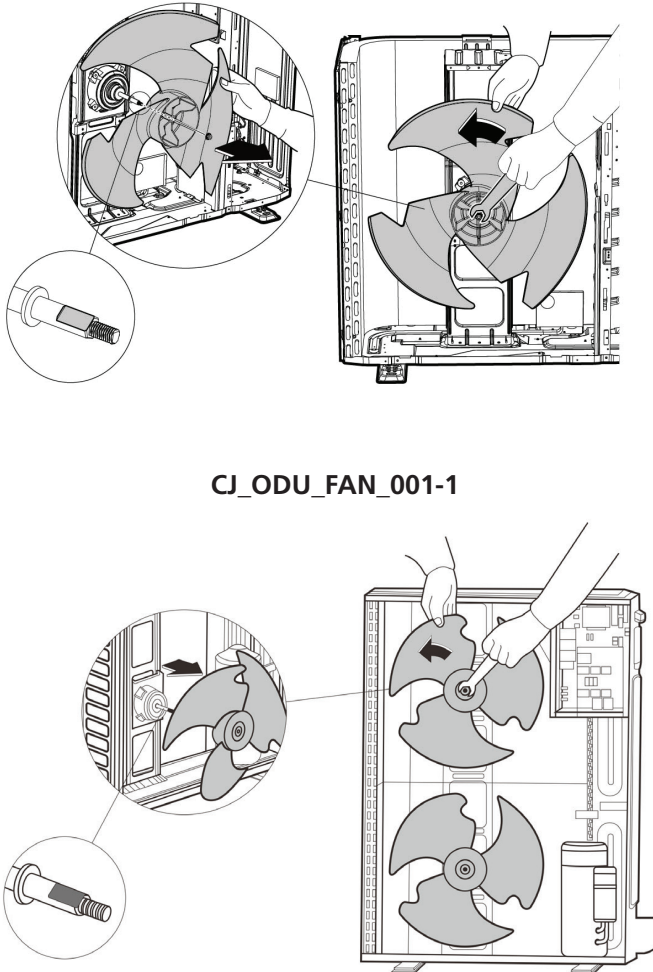
Procedure	Illustration
<p>1) Remove the nut securing the fan with a spanner (see CJ_ODU_FAN_001-1&2).</p> <p>2) Remove the fan.</p>	 <p style="text-align: center;">CJ_ODU_FAN_001-1</p> <p style="text-align: center;">CJ_ODU_FAN_001-2</p>

Note: This section is for reference only. Actual unit appearance may vary.

3.4 Fan Motor

Note: Remove the panel plate and the connection of fan motor on PCB (refer to 1.1 Panel Plate and 1.2 Electrical parts) before disassembling fan motor.

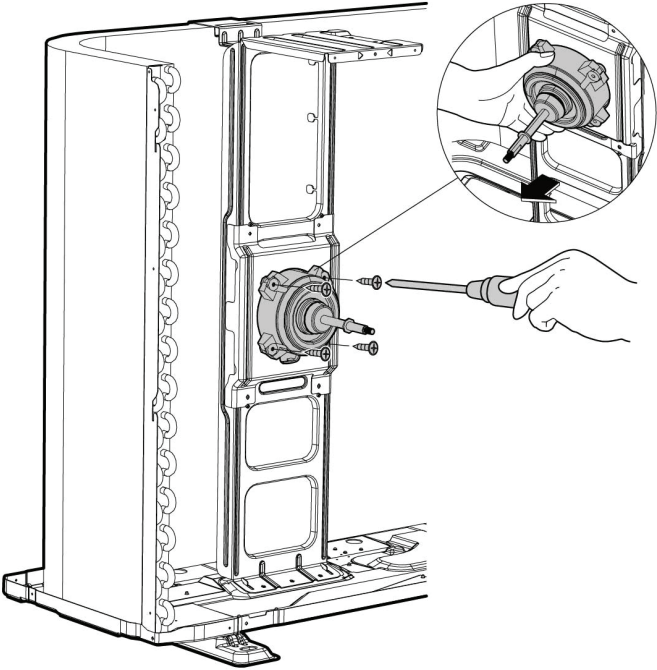
Procedure	Illustration
<p>3) Remove the fixing screws of the fan motor (4 screws) (see CJ_ODU_MOTOR_001).</p> <p>4) Remove the fan motor.</p>	 <p data-bbox="906 1115 1179 1146">CJ_ODU_MOTOR_001</p>

Note: This section is for reference only. Actual unit appearance may vary.

3.5 Sound blanket

Note: Remove the panel plate (refer to 1.1 Panel plate) before disassembling sound blanket.

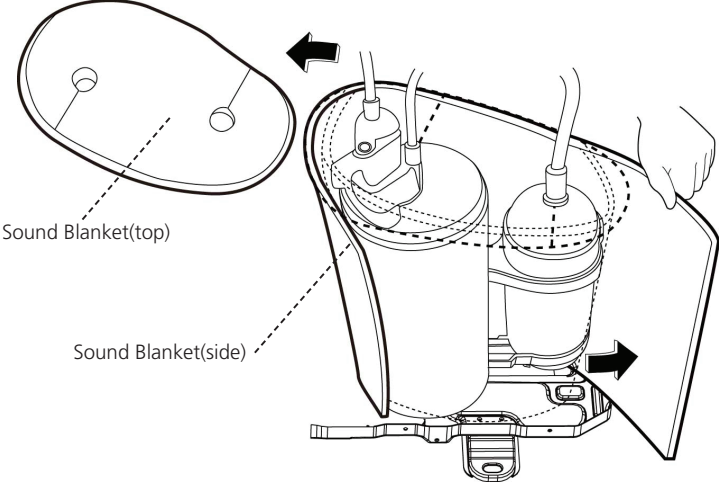
Procedure	Illustration
1) Remove the sound blanket (side and top) (see CJ_ODU_BLANKET_001).	 <p>The illustration shows a side view of an outdoor unit with a hand lifting a sound blanket. A separate diagram shows the sound blanket with two circular cutouts. Labels 'Sound Blanket(top)' and 'Sound Blanket(side)' point to the top and side of the blanket respectively. Arrows indicate the direction of removal.</p> <p>CJ_ODU_BLANKET_001</p>

Note: This section is for reference only. Actual unit appearance may vary.

3.6 Four-way valve (for heat pump models)

! WARNING: Evacuate the system and confirm that there is no refrigerant left in the system before removing the four-way valve and the compressor. (For R32 & R290, you should evacuate the system with the vacuum pump; flush the system with nitrogen; then repeat the two steps before heating up the brazed parts. The operations above should be implemented by professionals.)

Note: Remove the panel plate, connection of four-way valve on PCB (refer to 1.1 Panel plate and 1.2 Electrical parts) before disassembling sound blanket.

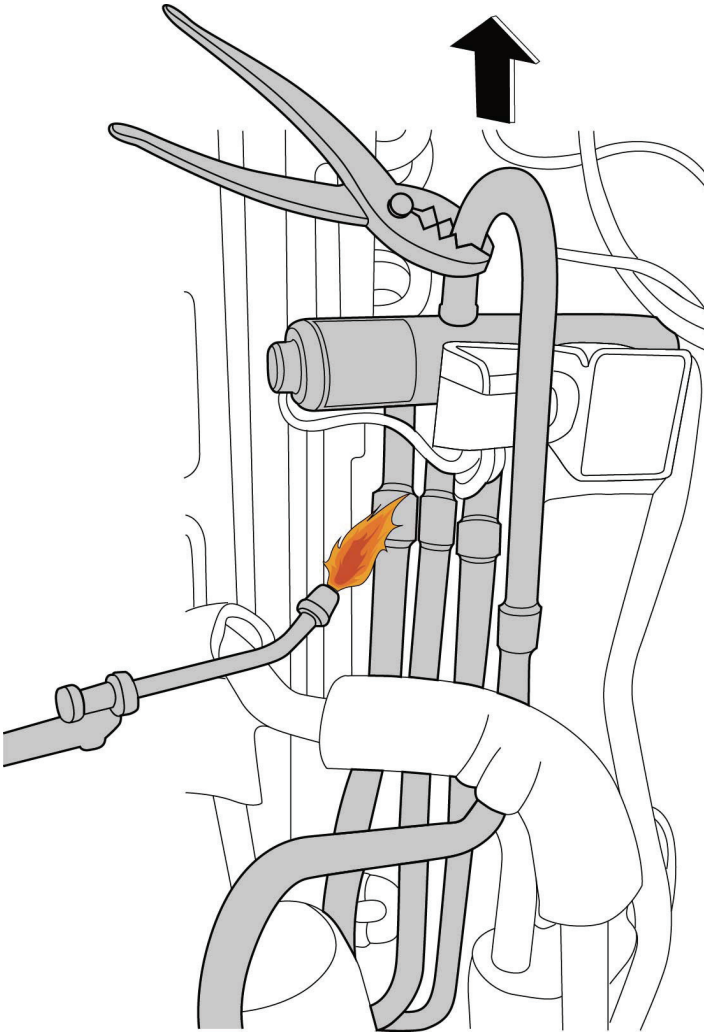
Procedure	Illustration
<ol style="list-style-type: none">1) Heat up the brazed parts and then detach the the four-way valve and the pipe (see CJ_ODU_VALVE_001).2) Remove the four-way valve assembly with pliers.	 <p data-bbox="911 1570 1162 1598">CJ_ODU_VALVE_001</p>

Note: This section is for reference only. Actual unit appearance may vary.

3.7 Compressor

⚠ WARNING: Evacuate the system and confirm that there is no refrigerant left in the system before removing the four-way valve and the compressor. (For R32 & R290, you should evacuate the system with the vacuum pump; flush the system with nitrogen; then repeat the two steps before heating up the brazed parts. The operations above should be implemented by professionals.)

Note: Remove the panel plate, connection of compressor on PCB (refer to 1.1 Panel plate and 1.2 Electrical parts) before disassembling sound blanket.

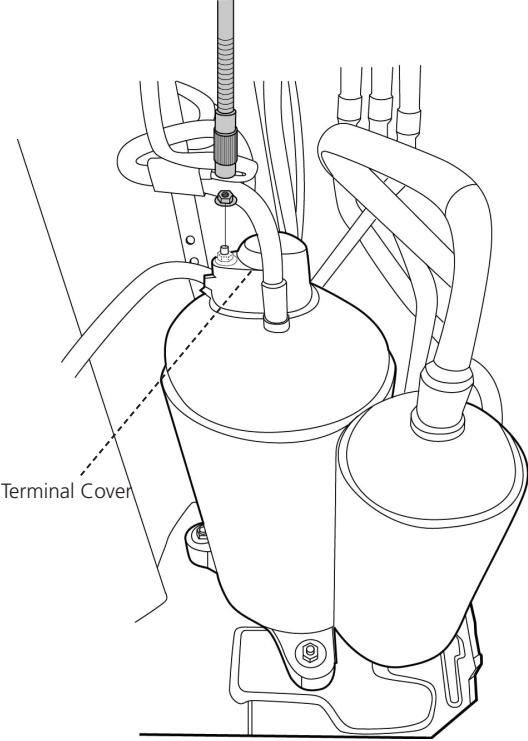
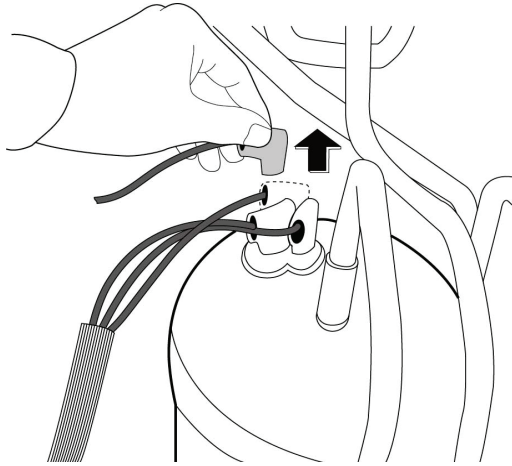
Procedure	Illustration
<p>1) Remove the flange nut of terminal cover and remove the terminal cover (see CJ_ODU_COMP_001).</p>	 <p style="text-align: center;">CJ_ODU_COMP_001</p>
<p>2) Disconnect the connectors (see CJ_ODU_COMP_002).</p>	 <p style="text-align: center;">CJ_ODU_COMP_002</p>

Note: This section is for reference only. Actual unit appearance may vary.

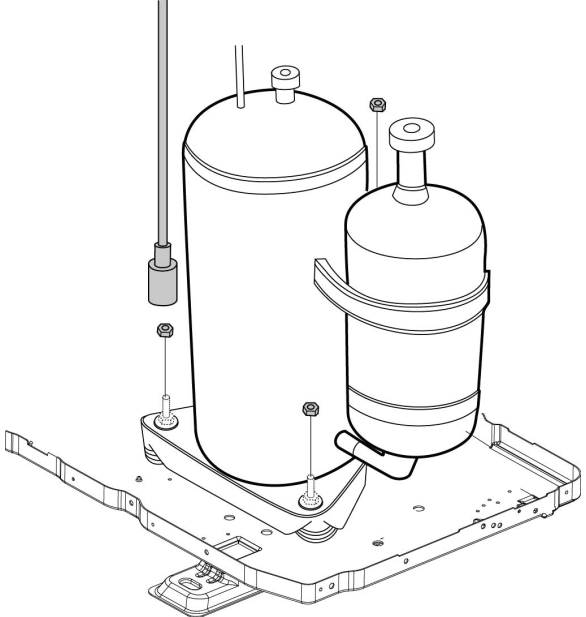
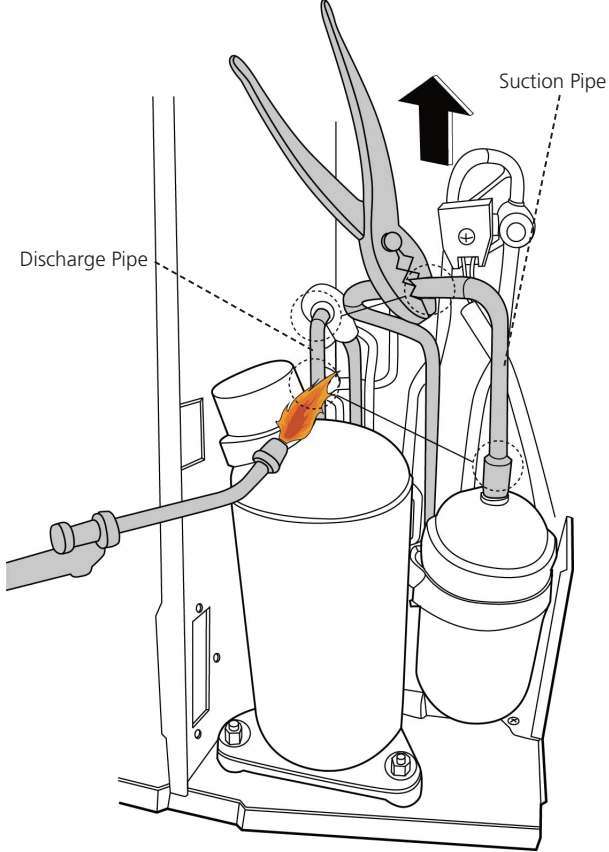
Procedure	Illustration
<p>3) Remove the hex nuts and washers securing the compressor, located on the bottom plate (see CJ_ODU_COMP_003).</p>	 <p style="text-align: center;">CJ_ODU_COMP_003</p>
<p>4) Heat up the brazed parts and then remove the the discharge pipe and the suction pipe (see CJ_ODU_COMP_004).</p> <p>5) Lift the compressor from the base pan assembly with pliers.</p>	 <p style="text-align: center;">CJ_ODU_COMP_004</p>

Note: This section is for reference only. Actual unit appearance may vary.

Troubleshooting

Contents

1. Safety Caution	3
2. General Troubleshooting	4
2.1 Error Display (Outdoor unit)	4
3. Outdoor Unit Point Check Function	6
4. Quick Maintenance by Error Code	10
5. Troubleshooting by Error Code.....	12
5.1 EC 51 (ODU EEPROM parameter error diagnosis and solution)	12
5.2 EL 01(IDU & ODU communication error diagnosis and solution)	13
5.3 EC 07 (Fan Speed Is Operating Outside of Normal Range)/EC 71(Over Current Failure of Outdoor DC Fan Motor) Diagnosis and Solution.....	16
5.4 EC 52/EC 53/EC 54/EC 56/EC 57/EC 5A/EC 5b/EC 5E/EC 50 (Open circuit or short circuit of temperature sensor diagnosis and solution)	18
5.5 PC 08(Current overload protection)/PC 44(ODU zero speed protection) /PC 46(Compressor speed has been out of control)/PC 49(Compressor overcurrent failure)	19
5.6 PC 00(IPM malfunction diagnosis and solution).....	21
5.7 PC 01(Over voltage or too low voltage protection)/PC 10(ODU low AC voltage protection)/PC 11(ODU main control board DC bus high voltage protection)/PC 12(ODU main control board DC bus low voltage protection /341 MCE error) Diagnosis and Solution	23
5.8 PC 40(Communication error between ODU main chip and compressor driven chip diagnosis and solution)	26
5.9 PC 0F(PFC module protection diagnosis and solution)	27
5.10 PC 06(Discharge temperature protection of compressor diagnosis and solution)	29
5.11 PC 0A(High temperature protection of condenser diagnosis and solution)	30

Troubleshooting

Contents

5.12	PC 02/LC 06 (Compressor top(or IPM) temp. protection diagnosis and solution).....	31
5.13	PC 30 (System high pressure protection diagnosis and solution)	33
5.14	PC 31 (System low pressure protection diagnosis and solution)	35
5.15	EC 72 (Lack phase failure of outdoor DC fan motor diagnosis and solution)	37
5.16	PC 43 (ODU compressor lack phase protection diagnosis and solution).....	38
5.17	PC 45 (ODU IR chip drive failure diagnosis and solution).....	39
5.18	CE (Automatic correction of wiring/piping error)	39
5.19	EH C1(Refrigerant sensor detects leakage diagnosis and solution)	40
5.20	EC 55(ODU IPM module temperature sensor malfunction diagnosis and solution)	41
5.21	EC 5C(Pressure sensor failure diagnosis and solution)	42
5.22	PC 13(The AC power is cut off or the AC voltage detection circuit fails diagnosis and solution)	43
5.23	PC A1(Condensation protection of refrigerant pipe diagnosis and solution).....	44
6.	Check Procedures	

1. Safety Caution

WARNING

Be sure to turn off all power supplies or disconnect all wires to avoid electric shock. While checking indoor/outdoor PCB, please equip oneself with antistatic gloves or wrist strap to avoid damage to the board.

WARNING

Electricity remains in capacitors even when the power supply is off. Ensure the capacitors are fully discharged before troubleshooting.

2. General Troubleshooting

2.1 Error Display

Display	Malfunction or Protection	Solution
dF	Defrosting	Normal Display, not error code
FC	Forced cooling	
EE07	ODU fan speed out of control	TS16
EE71	Over current failure of outdoor DC fan motor	TS16
EE72	Lack phase failure of outdoor DC fan motor	TS23
EE50	ODU temp. sensor error(T3,T4.TP)	TS18
EE51	ODU EEPROM parameter error	TS12
EE52	ODU coil temp. sensor(T3) error	TS18
EE53	ODU ambient temp. sensor(T4) error	TS18
EE54	COMP. discharge temp. sensor(TP) error	TS18
EE55	ODU IPM module temperature sensor malfunction	TS42
EE56	IDU coil outlet temp. sensor(T2B) error	TS18
EE57	Refrigerant pipe temperature sensor error	TS18
EE5R	Failure of enthalpy inlet temperature sensor	TS18
EE5b	Failure of enthalpy outlet temperature sensor	TS18
EE5E	Condenser temperature sensor(T3B) failure	TS18
EE5C	Pressure sensor failure	TS43
EHCI	Refrigerant sensor detects leakage	TS41
EL01	IDU & ODU communication error	TS13
PC00	IPM module protection	TS21
PC02	Compressor top(or IPM) temp. protection	TS32
PC06	Discharge temperature protection of compressor	TS29
PC08	Outdoor overcurrent protection	TS19
PC0R	High temperature protection of condenser	TS30
PC0F	PFC module protection	TS27

PC 0L	Low ambient temperature protection	--
PC 10	ODU low AC voltage protection	TS23
PC 11	ODU main control board DC bus high voltage protection	TS23
PC 12	ODU main control board DC bus low voltage protection /B41 MCE error	TS23
PC 13	The AC power is cut off or the AC voltage detection circuit fails	TS44
PC 30	System high pressure protection	TS34
PC 31	System low pressure protection	TS36
PC 40	Communication error between ODU main chip and compressor driven chip	TS26
PC 43	ODU compressor lack phase protection	TS39
PC 44	ODU zero speed protection	TS19
PC 45	ODU IR chip drive failure	TS40
PC 46	Compressor speed has been out of control	TS19
PC 49	Compressor overcurrent failure	TS19
PC R1	Condensation protection of refrigerant pipe	TS45
LC 06	High temperature protection of Inverter module (IPM)	TS32

3. Outdoor Unit Point Check Function

- A check switch is included on the auxiliary PCB.
- Push SW1 to check the unit's status while running. The digital display shows the following codes each time the SW1 is pushed.

Number of Presses	Display	Remark
0	Normal display	Displays running frequency, running state, or malfunction code
1	Quantity of indoor units with working connection	Display Number of indoor unit
2	Outdoor unit running mode code	Standby: 0, Fan only: 1, Cooling/Drying: 2, Heating: 3, Forced cooling: 6, Forced defrosting: A
3	Indoor unit A capacity	The capacity unit is horse power. If the indoor unit is not connected, the digital display shows the following: "--" (6K:0.6HP, 7K:0.8HP, 9K:1.0HP, 12K:1.2HP, 18K:1.5HP, 24K:2.5HP, 30K:3.0HP, 36K:3.2HP)
4	Indoor unit B capacity	
5	Indoor unit C capacity	
6	Indoor unit D capacity	
7	Indoor unit E capacity	
8	Indoor unit A capacity demand code	Norm code*HP (6K:0.6HP, 7K:0.8HP, 9K:1.0HP, 12K:1.2HP, 18K:1.5HP, 24K:2.5HP, 30K:3.0HP, 36K:3.2HP)
9	Indoor unit B capacity demand code	
10	Indoor unit C capacity demand code	
11	Indoor unit D capacity demand code	
12	Indoor unit E capacity demand code	
13	Outdoor unit amendatory capacity demand code	
14	The frequency corresponding to the total indoor units' amendatory capacity demand	
15	The frequency after the frequency limit	
16	The frequency sending to compressor control chip	
17	Indoor unit A evaporator outlet temperature (T2BA)	If the temperature is lower than -9°C, the digital display shows "-9." If the temperature is higher than 70°C, the digital display shows "70." If the indoor unit is not connected, the digital display shows: "--"
18	Indoor unit B evaporator outlet temperature (T2BB)	
19	Indoor unit C evaporator outlet temperature (T2BC)	
20	Indoor unit D evaporator outlet temperature (T2BD)	
21	Indoor unit E evaporator outlet temperature (T2BE)	

22	Indoor unit A room temperature (T1A)	If the temperature is lower than 0°C, the digital display shows "0." If the temperature is higher than 70°C, the digital display shows "70." If the indoor unit is not connected, the digital display shows: "--"
23	Indoor unit B room temperature (T1B)	
24	Indoor unit C room temperature (T1C)	
25	Indoor unit D room temperature (T1D)	
26	Indoor unit E room temperature (T1E)	
27	Indoor unit A evaporator temperature (T2A)	If the temperature is lower than -9°C, the digital display shows "-9." If the temperature is higher than 70°C, the digital display shows "70." If the indoor unit is not connected, the digital display shows: "--"
28	Indoor unit B evaporator temperature (T2B)	
29	Indoor unit C evaporator temperature (T2C)	
30	Indoor unit D evaporator temperature (T2D)	
31	Indoor unit E evaporator temperature (T2E)	
32	Condenser pipe temperature (T3)	
33	Outdoor ambient temperature (T4)	
34	Compressor discharge temperature (TP)	The display value is between 30–129°C. If the temperature is lower than 30°C, the digital display shows "30." If the temperature is higher than 99°C, the digital display shows single and double digits. For example, If the display shows 0.5, so 0.5 multiplied by 10 to become 5, then added to 100 to become 105°C.
35	AD value of current	The display value is a hex number.
36	AD value of AC voltage	For example, the digital display tube shows "Cd", so $C \times 16^1 + d \times 16^0 = 12 \times 16 + 13 = 205$, it means AD value is 205.
37	AD value of DC voltage	
38	EXV open angle for A indoor unit	Actual data/4. If the value is higher than 99, the digital display shows single and double digits. For example, if the digital display shows "2.0", so 2.0 multiplied by 10 to become 20, then added to 100 to become 120, the EXV open angle is $120 \times 4 = 480p$.
39	EXV open angle for B indoor unit	
40	EXV open angle for C indoor unit	
41	EXV open angle for D indoor unit	
42	EXV open angle for E indoor unit	
43	MVI open angle (for some models)	
44	EXI open angle (for some models)	

45	Frequency limit symbol	Bit7	Reserved	The display value is a hexadecimal number. For example, the digital display show 2A, the corresponding binary is 101010, so Bit5=1, Bit3=1, and Bit1=1. This means that a frequency limit may be caused by current, IPM or T3.
		Bit6	Frequency limit caused by voltage	
		Bit5	Frequency limit caused by current.	
		Bit4	Reserved	
		Bit3	Frequency limit caused by IPM.	
		Bit2	Frequency limit caused by Compressor discharge temperature(T5)	
		Bit1	Frequency limit caused by Outdoor heat exchanger pipe temperature(T3)	
		Bit0	Frequency limit caused by Middle indoor heat exchanger coil temperature(T2)	
46	T2B fault	00:No fault,01:T2B-A fault, ,02:T2B-B fault ,03:T2B-C fault,04:T2B-D fault, 05:T2B-E fault, 06:T2B-F fault(The display priority is A-B-C-D-E-F)		
47	Average value of T2	(Sum T2 value of all indoor units)/(number of indoor units in good connection)(The heating is the average value of T2, and the cooling is the average value of T2B) If the temperature is lower than -9°C, the digital display shows "-9".		
48	Outdoor unit fan speed	See next list		
49	Reason of stop			
50~59	Reserved			
60	Air injection enthalpy inlet temperature (for hyper heat models)	If the temperature is lower than -9°C, the digital display shows "-9". If the temperature is higher than 70°C, the digital display shows "70." If the indoor unit is not connected, the digital display shows: "--"		
61	Air injection enthalpy outlet temperature (for hyper heat models)			
62	Condenser coil middle temperature (for hyper heat models)			
63	Refrigerant tube inlet temperature (for hyper heat models)			
64	Target discharge temperature	The display value is between 0–199°C. If the temperature is lower than 30°C, the digital display shows "30." If the temperature is higher than 99°C, the digital display shows single and double digits. For example, If the display shows 0.5, so 0.5 multiplied by 10 to become 5, then added to 100 to become 105°C..		
65	Indoor unit F capacity	The capacity unit is horse power. If the indoor unit is not connected, the digital display shows the following: "--"		

66	Indoor unit F capacity demand code	Norm code*HP (9K: 1HP,12K: 1.2HP,18K: 1.5HP)
67	Indoor unit F evaporator outlet temperature (T2BF)	If the temperature is lower than -9°C, the digital display shows "-9." If the temperature is higher than 70°C, the digital display shows "70." If the indoor unit is not connected, the digital display shows: "--"
68	Indoor unit F room temperature (T1F)	If the temperature is lower than 0°C, the digital display shows "0." If the temperature is higher than 70°C, the digital display shows "70." If the indoor unit is not connected, the digital display shows: "--"
69	Indoor unit F evaporator temperature (T2F)	If the temperature is lower than -9°C, the digital display shows "-9." If the temperature is higher than 70°C, the digital display shows "70." If the indoor unit is not connected, the digital display shows: "--"
70	EXV open angle for F indoor unit	Actual data/4. If the value is higher than 99, the digital display shows single and double digits.
71	IPM module temperature	The display value is between 0–199°C. If the temperature is higher than 99°C, the digital display shows single and double digits. For example, If the display shows 5.0, so 5.0 multiplied by 10 to become 50, then added to 100 to become 150°C.
72	The high pressure sensor detects the pressure corresponding to the condensation temperature(Tc)	The digital display shows: "--"
73	Reserved	
74		

Outdoor unit fan speed corresponding table:

Outdoor unit fan speed	Display
>600rpm	02
>300rpm & ≤ 600rpm	03
≤300rpm	04

4. Quick Maintenance by Error Code

If you do not have the time to test which specific parts are faulty, you can directly change the required parts according to the error code. You can find the parts to replace by error code in the following table.

Part requiring replacement	Error Code											
	EL 01	EC 50	EC 51	EC 52	EC 53	EC 54	EC 55	EC 56	EC 57	EC 5A	EC 5b	EC5E
Indoor PCB	✓	x	x	x	x	x	x	x	x	x	x	x
Outdoor PCB	✓	✓	✓	✓	✓	✓	✓	✓	✓	✓	✓	✓
ODU coil temp. sensor	x	✓	x	✓	x	x	x	x	x	x	x	x
ODU ambient temp. sensor	x	✓	x	x	✓	x	x	x	x	x	x	x
COMP. discharge temp. sensor	x	✓	x	x	x	✓	x	x	x	x	x	x
IPM module temperature sensor	x	x	x	x	x	x	✓	x	x	x	x	x
IDU coil outlet temp. sensor	x	x	x	x	x	x	x	✓	x	x	x	x
Refrigerant pipe temperature sensor	x	x	x	x	x	x	x	x	✓	x	x	x
Enthalpy inlet temperature sensor	x	x	x	x	x	x	x	x	x	✓	x	x
Enthalpy outlet temperature sensor	x	x	x	x	x	x	x	x	x	x	✓	x
Condenser temperature sensor	x	x	x	x	x	x	x	x	x	x	x	✓
Reactor	✓	x	x	x	x	x	x	x	x	x	x	x
IPM module board	✓	x	x	x	x	x	x	x	x	x	x	x

Part requiring replacement	Error Code									
	EC 5C	EH C1	EC 07/EC 71	PC 00	PC 01/PC 10/PC 11/PC 12	PC 02	PC 08/PC 44/PC 45/PC 49	PC 13	PC 11	PC 0F
Outdoor PCB	✓	x	✓	✓	✓	✓	✓	✓	✓	✓
Outdoor fan motor	x	x	✓	✓	x	x	✓	x	x	x
Reactor or inductance	x	x	x	✓	✓	x	✓	x	x	✓
Compressor	x	x	x	✓	x	x	x	x	x	x
IPM module board	x	x	x	✓	✓	x	✓	x	x	x
Bridge rectifier	x	x	x	✓	✓	x	✓	x	x	x
Pressure sensor	✓	x	x	x	x	x	x	x	x	x
PFC module	x	x	x	x	x	x	x	x	x	✓
Additional refrigerant	x	✓	x	x	x	x	x	x	x	x
Over load protector	x	x	x	x	x	✓	x	x	x	x
ODU ambient temp. sensor	x	x	x	x	x	x	x	x	✓	x
Refrigerant pipe temperature sensor	x	x	x	x	x	x	x	x	✓	x

Part requiring replacement	Error Code							
	PC 40	EC 72	PC 43	PC 45	PC 06	PC 0R	PC 30	PC 31
Outdoor PCB	✓	✓	✓	x	✓	✓	✓	✓
Outdoor fan motor	x	✓	x	x	x	✓	✓	✓
ODU coil temp. sensor	x	x	x	x	x	✓	x	x
COMP. discharge temp. sensor	x	x	x	x	✓	x	x	x
Compressor	x	x	✓	x	x	x	x	x
IPM module board	x	x	x	✓	x	x	x	x
Additional refrigerant	x	x	x	x	✓	✓	x	✓
Electric control box	✓	x	x	x	x	x	x	x
High pressure switch	x	x	x	x	x	x	✓	x
Low pressure switch	x	x	x	x	x	x	x	✓

5. Troubleshooting by Error Code

5.1 EC 51 (ODU EEPROM parameter error diagnosis and solution)

Description: Indoor or outdoor PCB main chip does not receive feedback from EEPROM chip.

Recommended parts to prepare:

- Indoor PCB
- Outdoor PCB

Troubleshooting and repair:

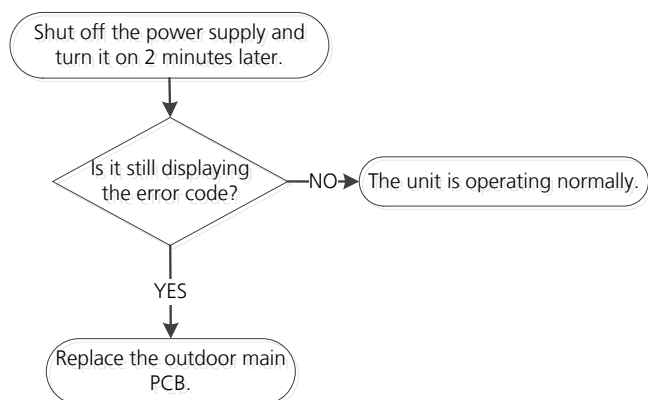

Remarks:

EEPROM: A read-only memory whose contents can be erased and reprogrammed using a pulsed voltage.

The location of the EEPROM chip on the indoor and outdoor PCB is shown in the following two images:

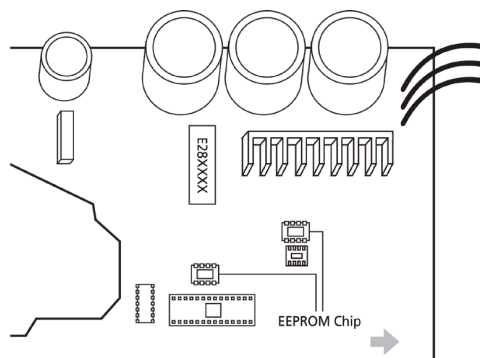

This pictures are only for reference, actual appearance may vary.

5.2 EL 01(IDU & ODU communication error diagnosis and solution)

Description: Indoor unit does not receive the feedback from outdoor unit during 110 seconds and this condition happens 4 times continuously.

Recommended parts to prepare:

- Indoor PCB
- Outdoor PCB
- IPM module board
- Reactor

Troubleshooting and repair:

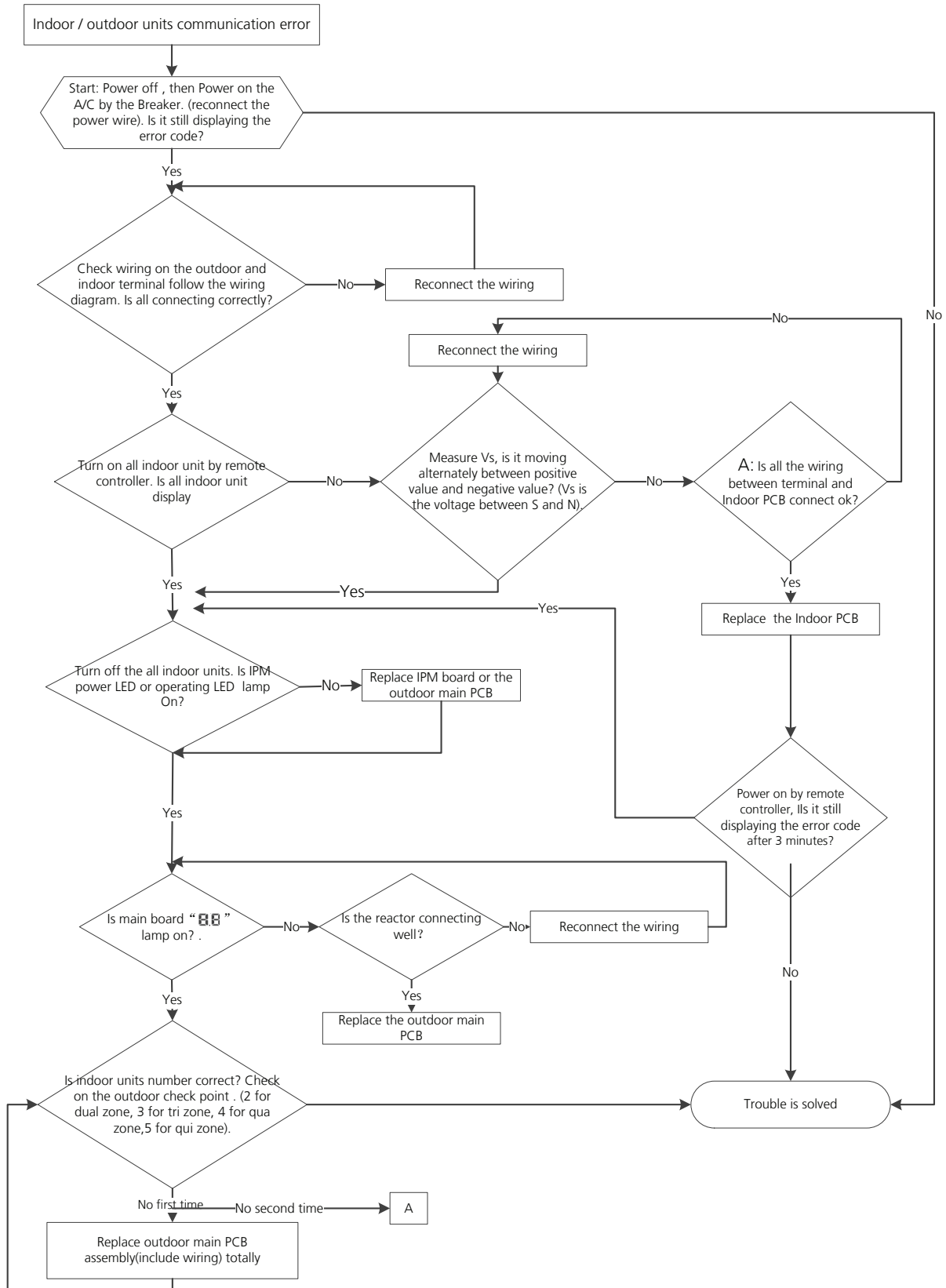

Remarks:

- Use a multimeter to test the resistance of the reactor which does not connect with capacitor.
- The normal value should be around zero ohm. Otherwise, the reactor must have malfunction.

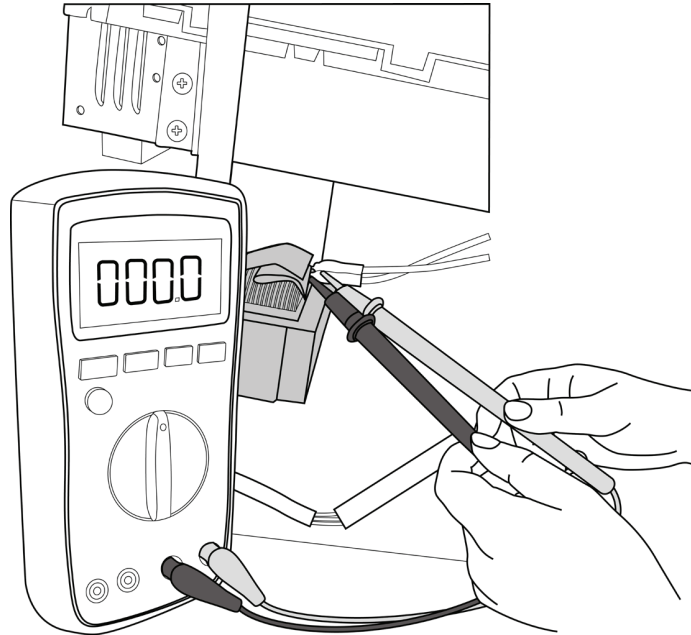

Note: The picture and the value are only for reference, actual condition and specific value may vary.

5.3 EC 07 (Fan Speed Is Operating Outside of Normal Range)/EC 71(Over Current Failure of Outdoor DC Fan Motor) Diagnosis and Solution

Description: When indoor / outdoor fan speed keeps too low or too high for a certain time, the LED displays the failure code and the AC turns off.

Recommended parts to prepare:

- Connection wires
- Fan assembly
- Fan motor
- PCB

Troubleshooting and repair:

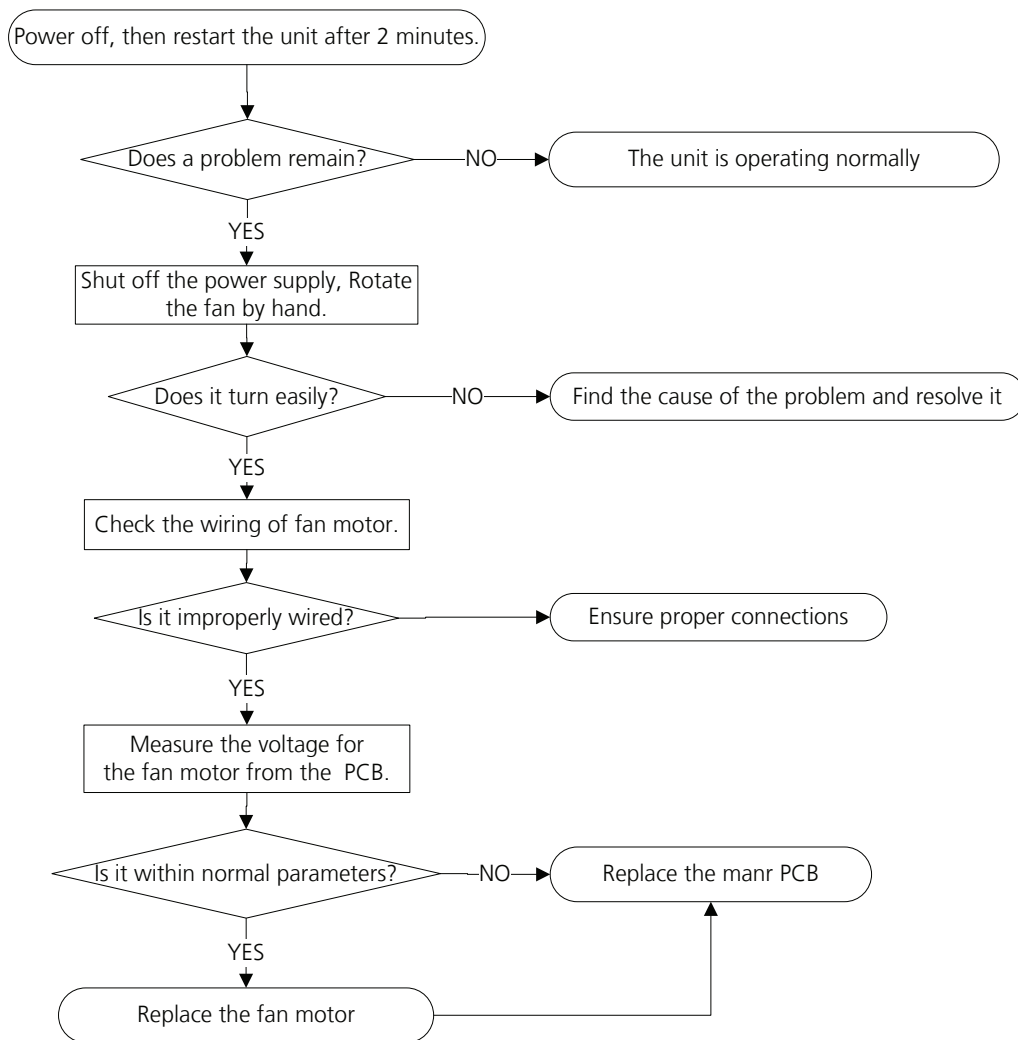

Index:**1. Outdoor DC Fan Motor(control chip is in fan motor)**

Power on and when the unit is in standby, measure the voltage of pin1-pin3, pin4-pin3 in fan motor connector. If the value of the voltage is not in the range showing in below table, the PCB must has problems and need to be replaced.

- DC motor voltage input and output (voltage: 220-240V~):

No.	Color	Signal	Voltage
1	Red	Vs/Vm	192V~380V
2	---	---	---
3	Black	GND	0V
4	White	Vcc	13.5-16.5V
5	Yellow	Vsp	0~6.5V
6	Blue	FG	13.5-16.5V

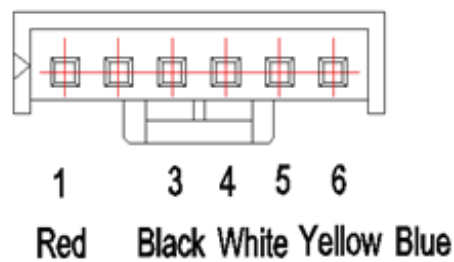
**2. Outdoor DC Fan Motor (control chip is in outdoor PCB)**

Release the UVW connector. Measure the resistance of U-V, U-W, V-W. If the resistance is not equal to each other, the fan motor must has problems and need to be replaced. otherwise the PCB must has problems and need to be replaced.

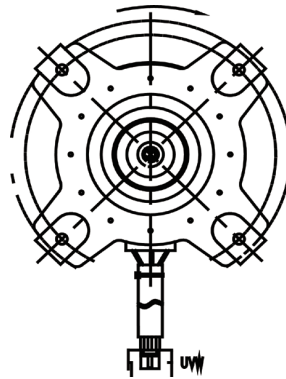

5.4 EC 52/EC 53/EC 54/EC 56/EC 57/EC 5A/EC 5b/EC 5E/EC 50 (Open circuit or short circuit of temperature sensor diagnosis and solution)

Description: If the sampling voltage is lower than 0.06V or higher than 4.94V, the LED displays the failure code.

Recommended parts to prepare:

- Connection wires
- Sensors
- PCB

Troubleshooting and repair:

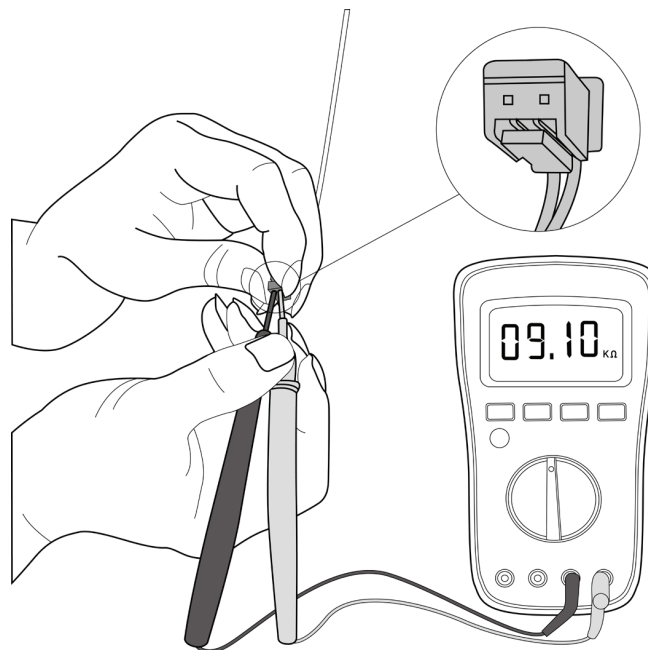
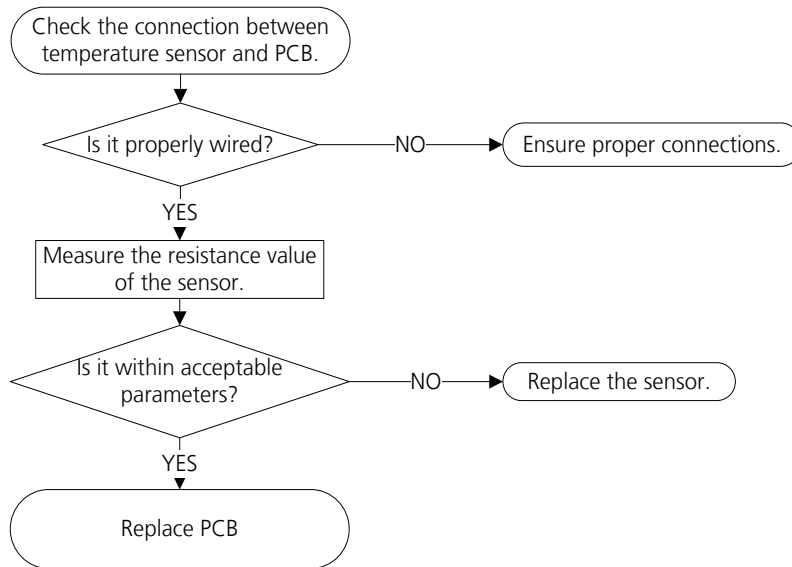

This picture and the value are only for reference, actual appearance and value may vary

5.5 PC 08(Current overload protection)/PC 44(ODU zero speed protection) /PC 46(Compressor speed has been out of control)/PC 49(Compressor overcurrent failure)

Description: An abnormal current rise is detected by checking the specified current detection circuit.

Recommended parts to prepare:

- Outdoor PCB
- Connection wires
- Bridge rectifier
- PFC circuit or reactor
- Refrigeration piping system
- Pressure switch
- Outdoor fan
- IPM module board

Troubleshooting and repair:

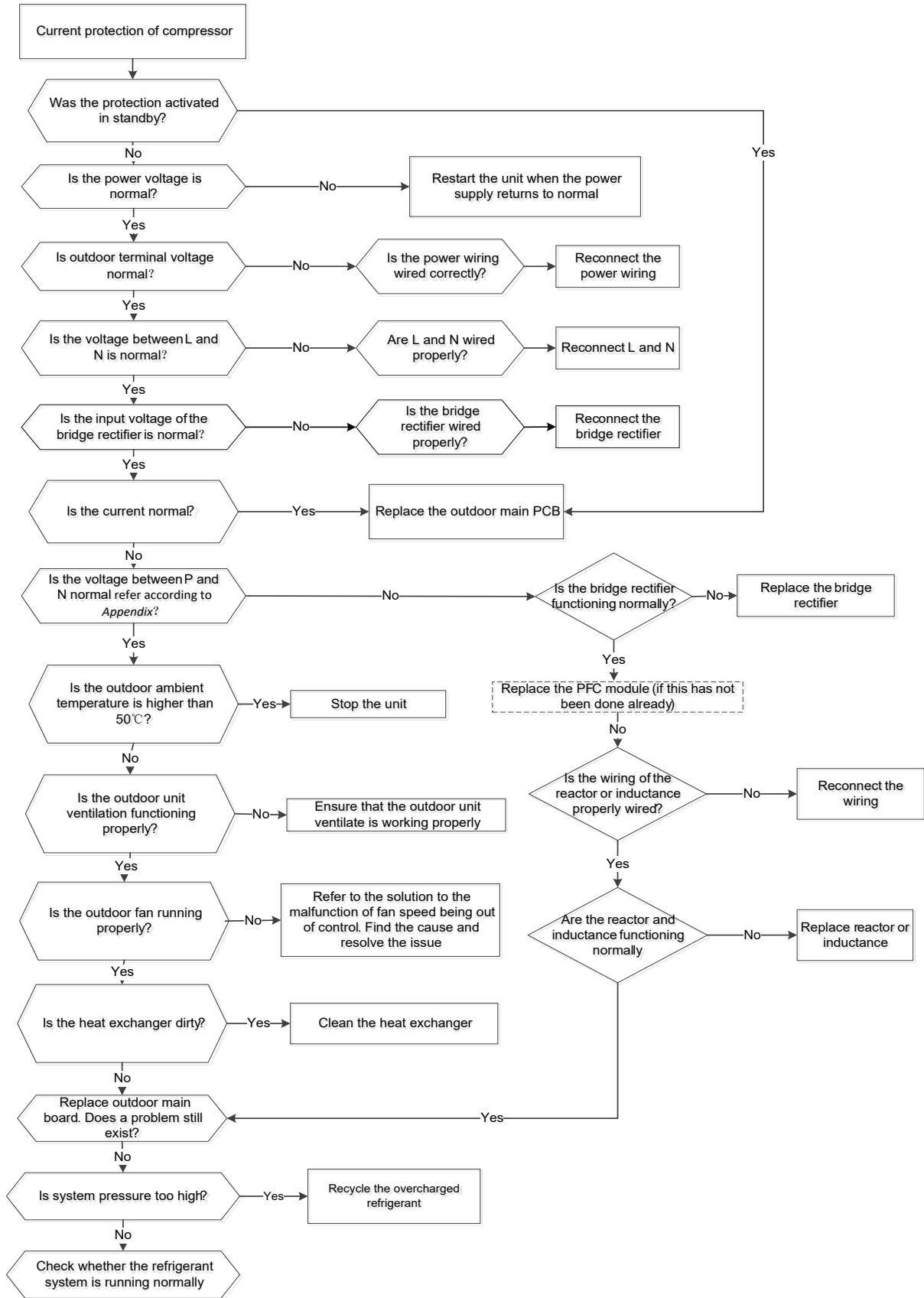

5.6 PC 00(IPM malfunction diagnosis and solution)

Description: When the voltage signal the IPM sends to the compressor drive chip is abnormal, the LED displays the failure code and the AC turns off.

Recommended parts to prepare:

- Connection wires
- IPM module board
- Outdoor fan assembly
- Compressor
- Outdoor PCB
- Reactor or inductance
- Bridge rectifier

Troubleshooting and repair:

At first test the resistance between every two ports of U, V, W of IPM and P, N. If any result of them is 0 or close to 0, the IPM is defective. Otherwise, please follow the procedure below:

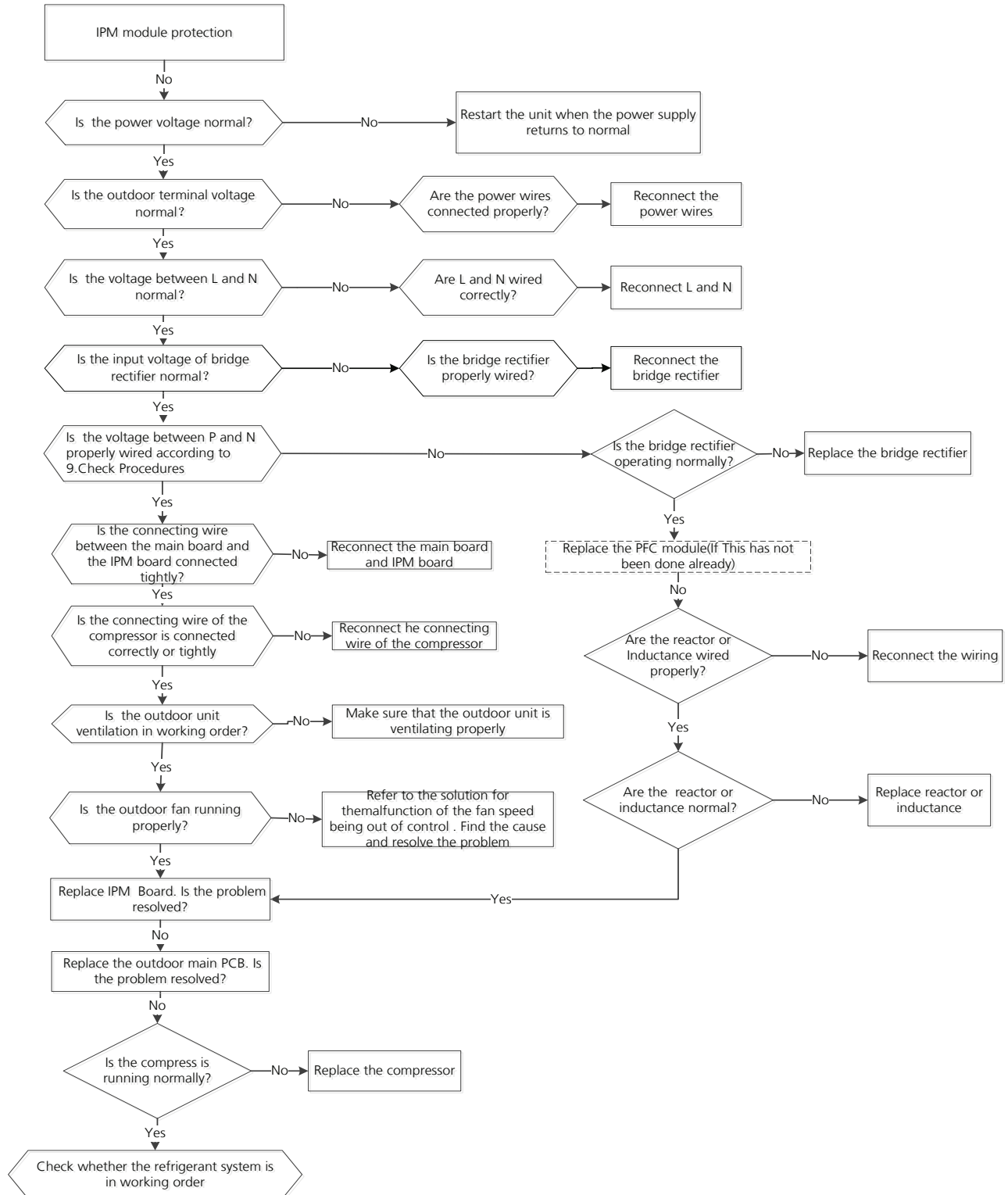

5.7 PC 01(Over voltage or too low voltage protection)/PC 10(ODU low AC voltage protection)/PC 11(ODU main control board DC bus high voltage protection)/PC 12(ODU main control board DC bus low voltage protection /341 MCE error) Diagnosis and Solution

Description: Abnormal increases or decreases in voltage are detected by checking the specified voltage detection circuit.

Recommended parts to prepare:

- Power supply wires
- IPM module board
- Outdoor PCB
- Bridge rectifier
- PFC circuit or reactor

Troubleshooting and repair:

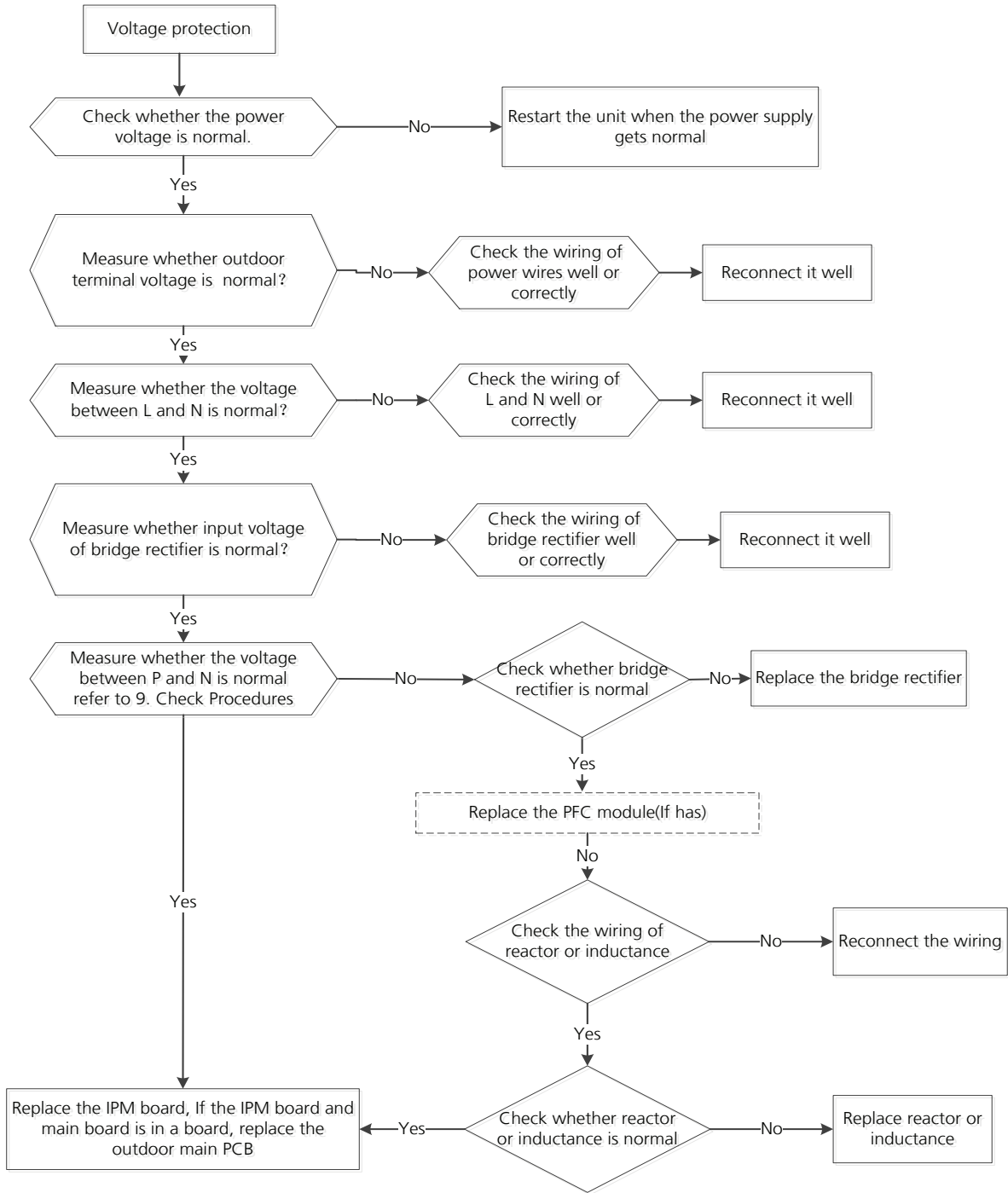

5.8 PC 40(Communication error between ODU main chip and compressor driven chip diagnosis and solution)

Description: The main PCB cannot detect the IPM board.

Recommended parts to prepare:

- Connection wires
- Outdoor PCB
- IPM module board
- Electric control box

Troubleshooting and repair:

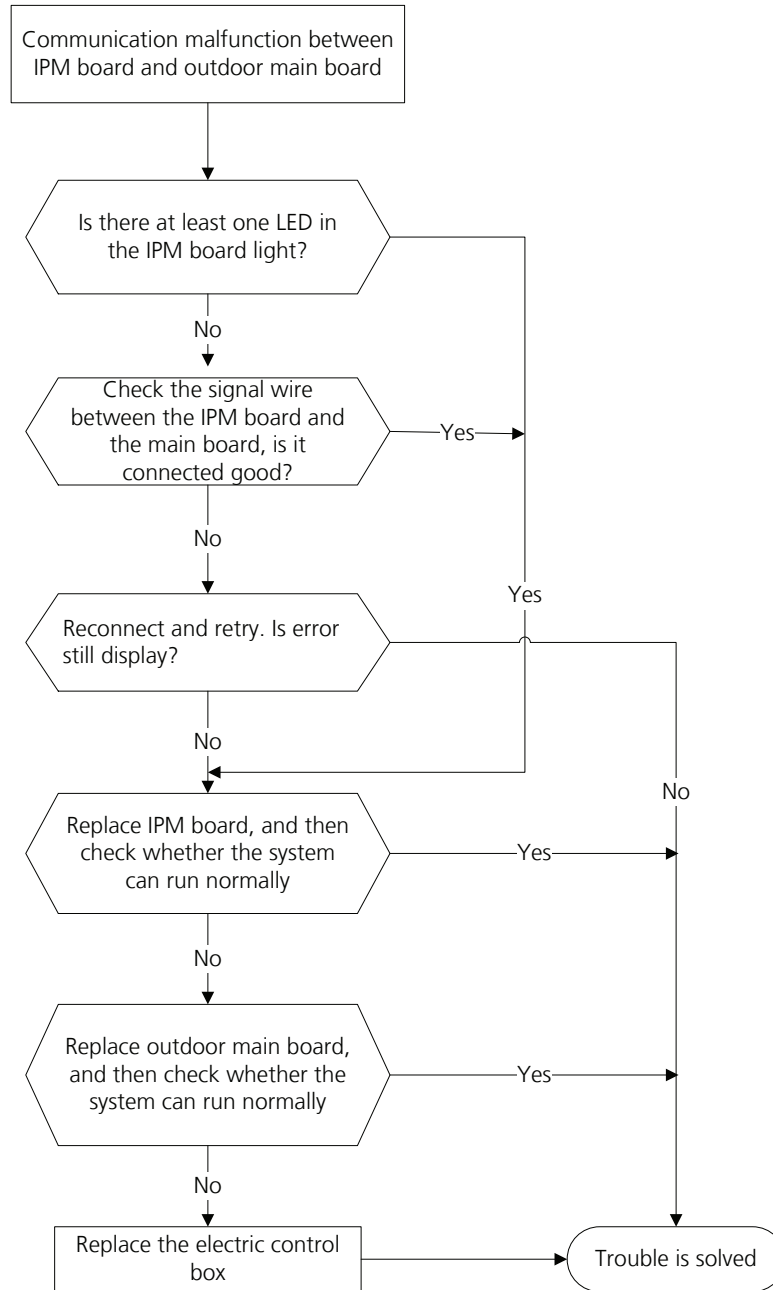

5.9 PC 0F(PFC module protection diagnosis and solution)

Description: Outdoor PCB detects PFC signal is low voltage or DC voltage is lower than 340V for 6s when quick check.

Recommended parts to prepare:

- Connection wires
- Outdoor PCB
- Inductance
- PFC circuit or IPM module board

Troubleshooting and repair:

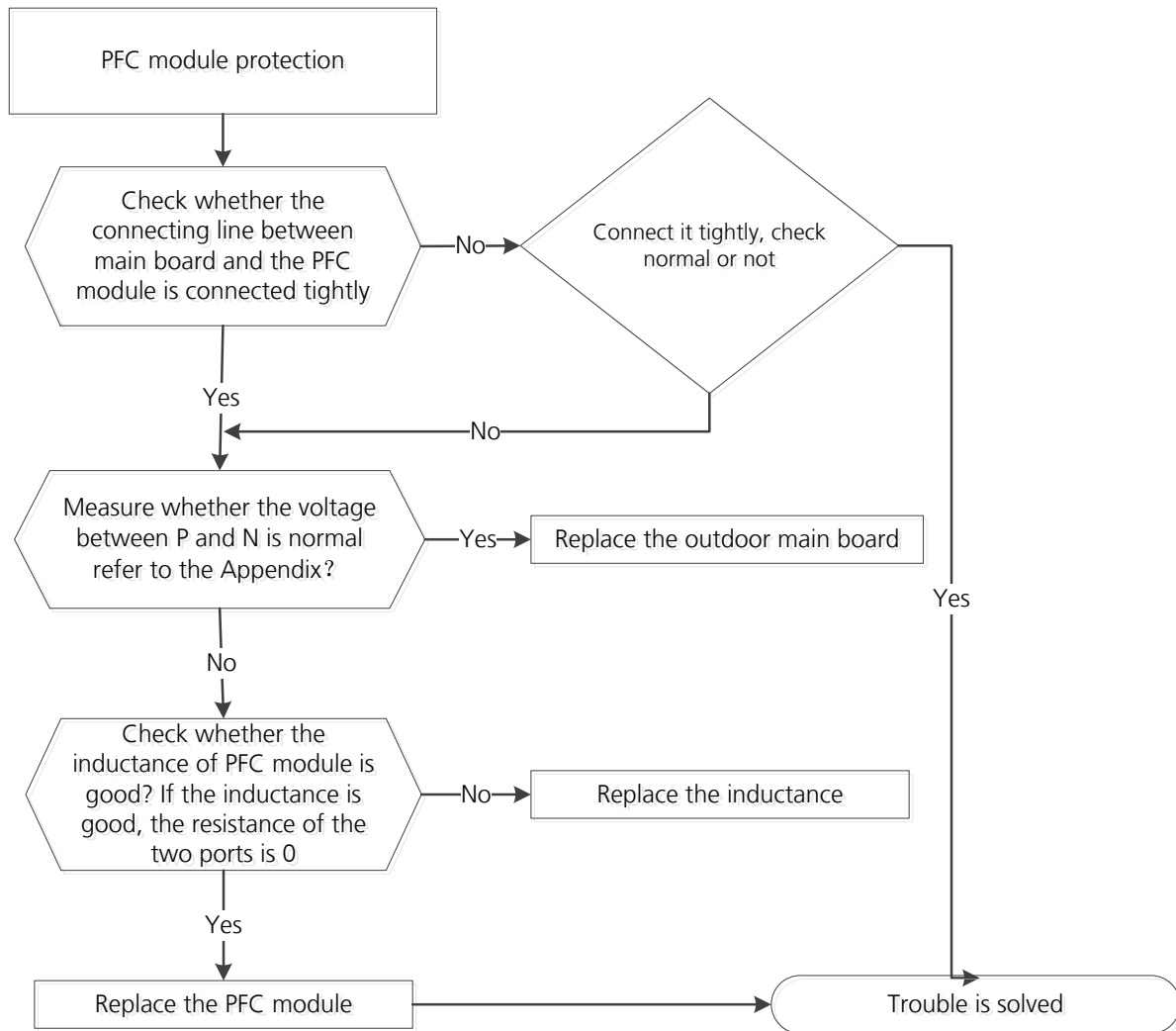

5.10 PC 06(Discharge temperature protection of compressor diagnosis and solution)

Description: When the compressor discharge temperature (T5) is more than 115°C for 10 seconds, the compressor ceases operation and does not restart until T5 is less than 90°C

Recommended parts to prepare:

- Connection wires
- Outdoor PCB
- Discharge temperature sensor
- Refrigerant

Troubleshooting and repair:

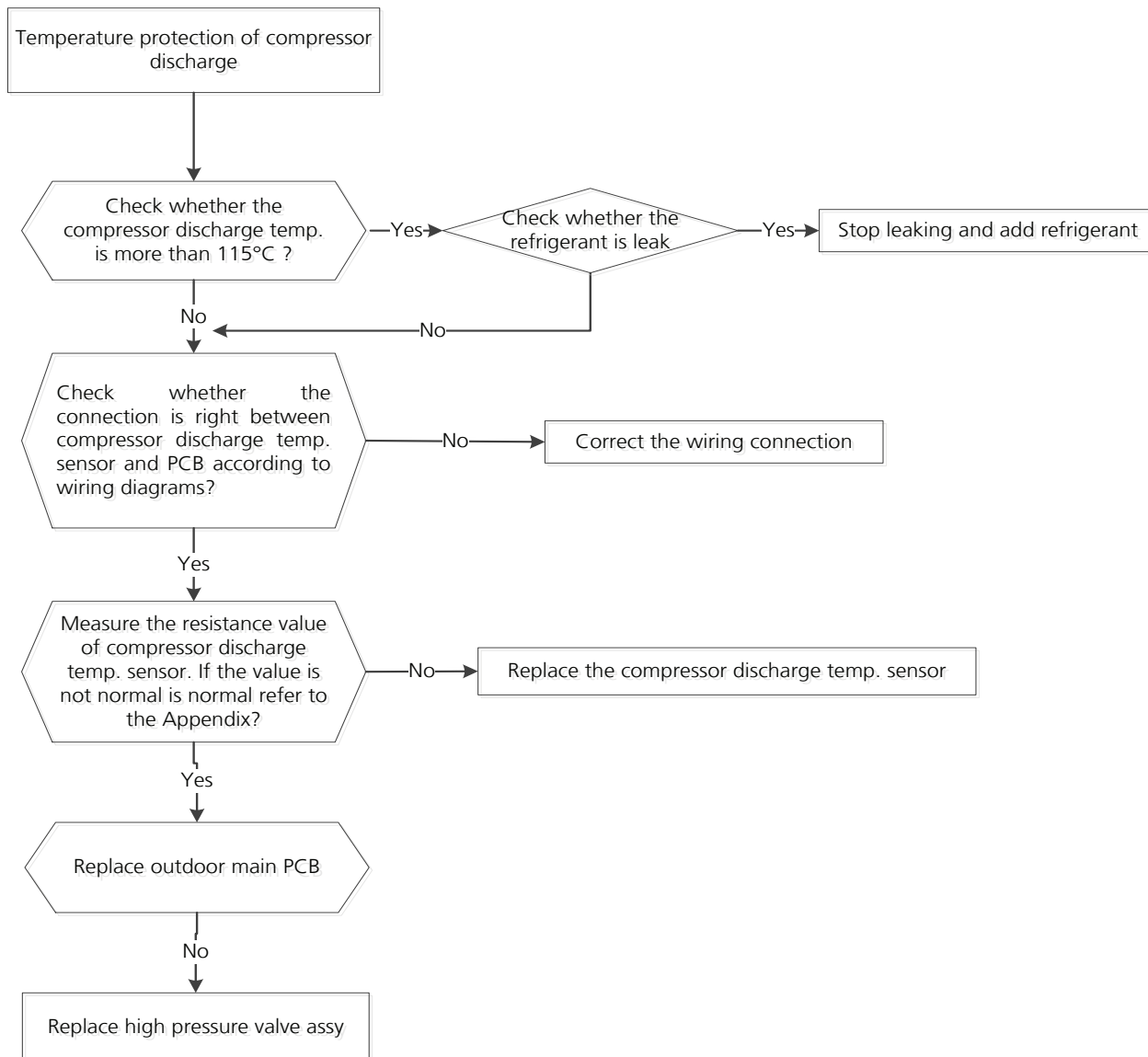

5.11 PC 0A(High temperature protection of condenser diagnosis and solution)

Description: The unit will stop when condenser temperature is higher than 65°C, and runs again when it is less than 52°C

Recommended parts to prepare:

- Connection wires
- Condenser temperature sensor
- Outdoor fan
- Outdoor main PCB
- Refrigerant

Troubleshooting and repair:

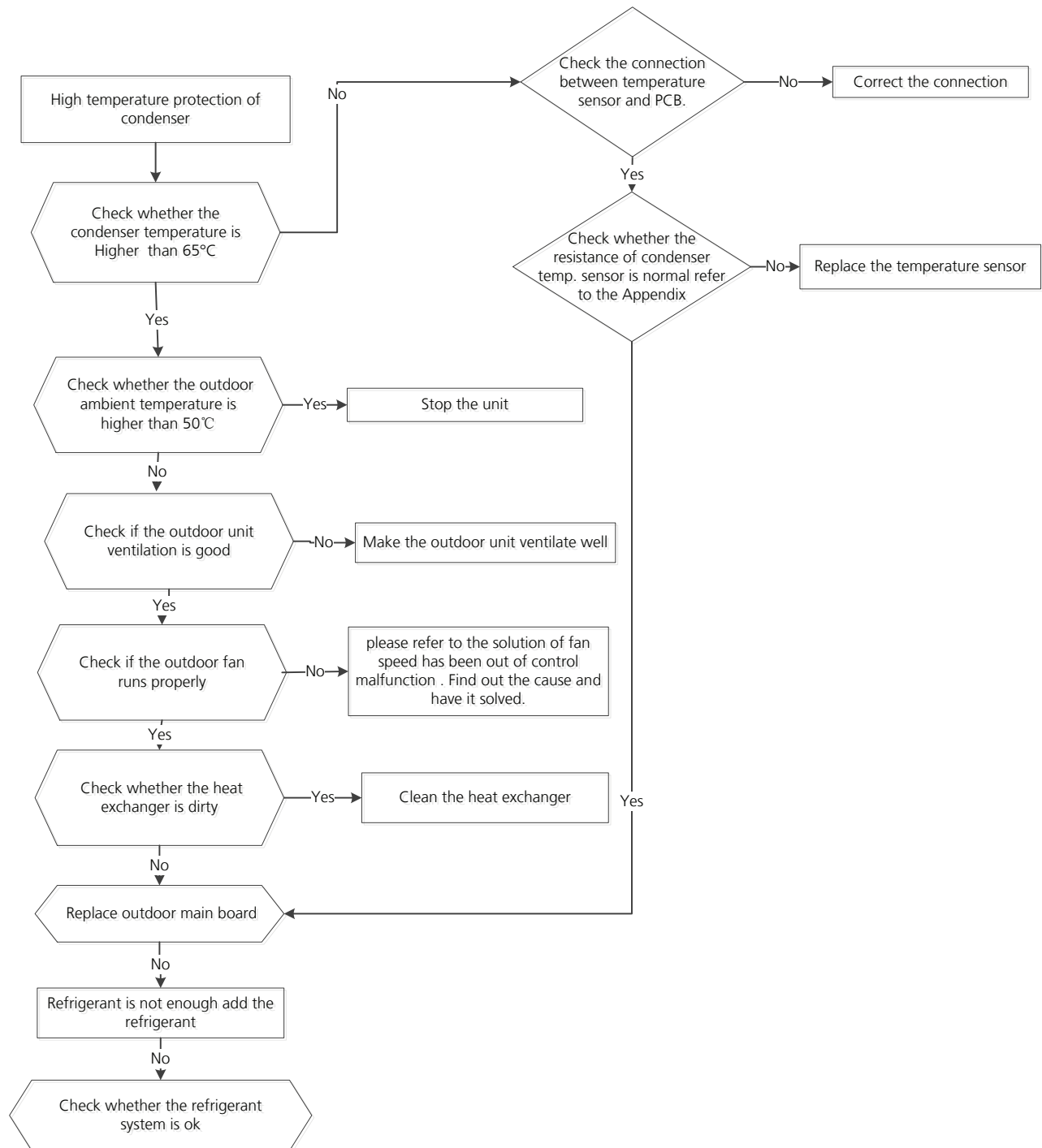

5.12 PC 02/LC 06 (Compressor top(or IPM) temp. protection diagnosis and solution)

Description: For some models with overload protector, If the sampling voltage is not 5V, the LED will display the failure. If the temperature of IPM module is higher than a certain value, the LED displays the failure code.

Models without overload protector should be diagnosed according to the second flowchart.

Recommended parts to prepare:

- Connection wires
- Outdoor PCB
- IPM module board
- High pressure protector
- System blockages

Troubleshooting and repair:

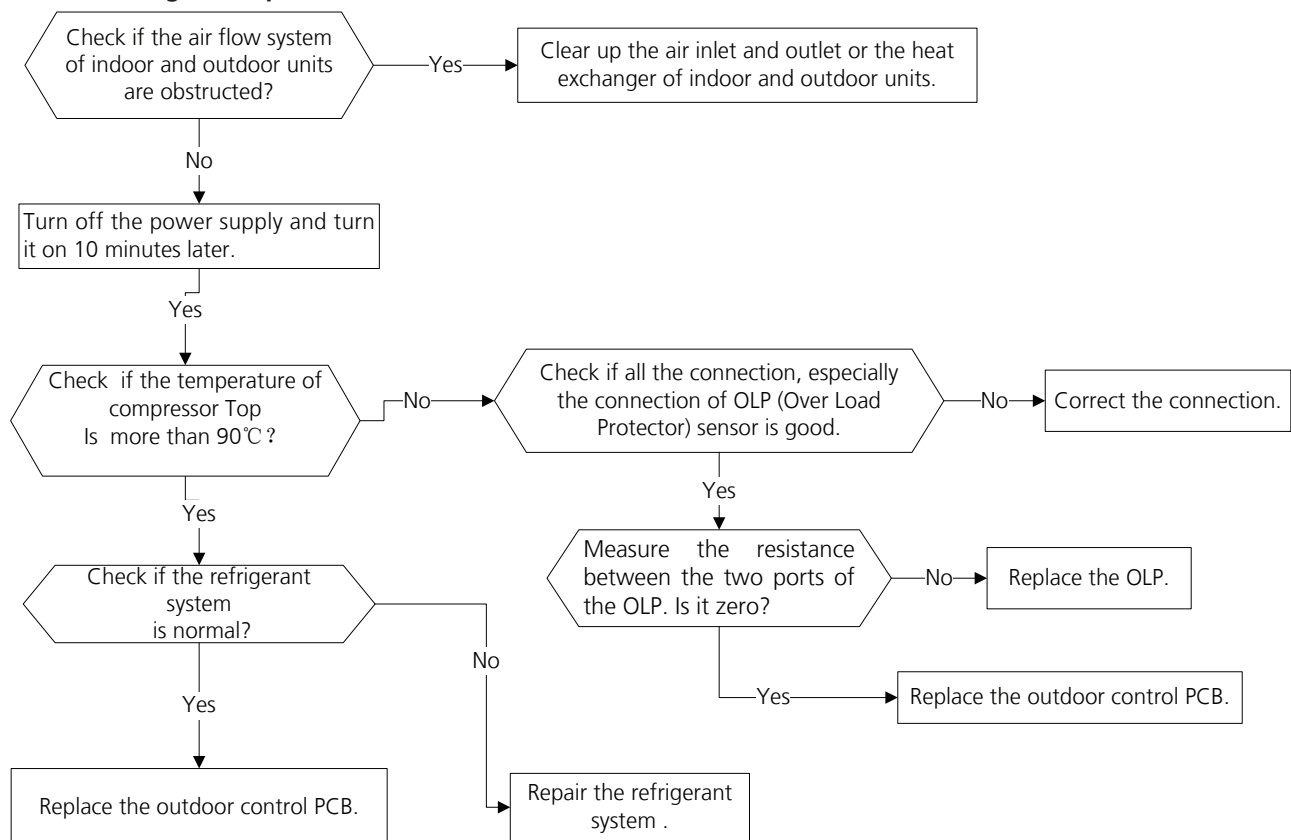

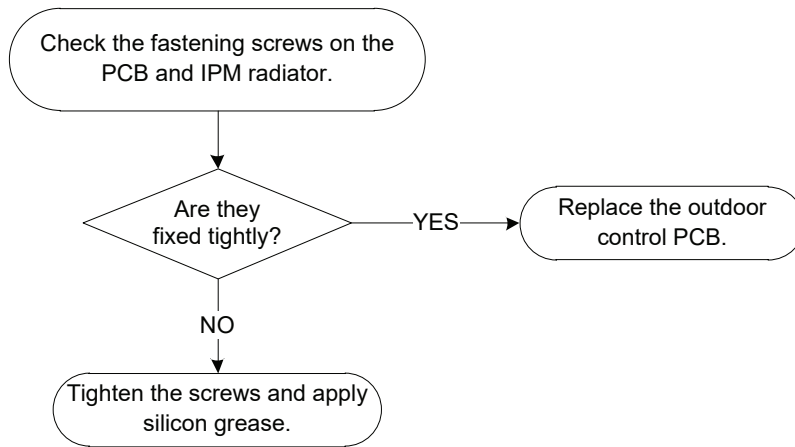

5.13 PC 30 (System high pressure protection diagnosis and solution)

Description: Outdoor pressure switch cut off the system because high pressure is higher than 4.4 MPa

Recommended parts to prepare:

- Connection wires
- Pressure switch
- Outdoor fan
- Outdoor main PCB

Troubleshooting and repair:

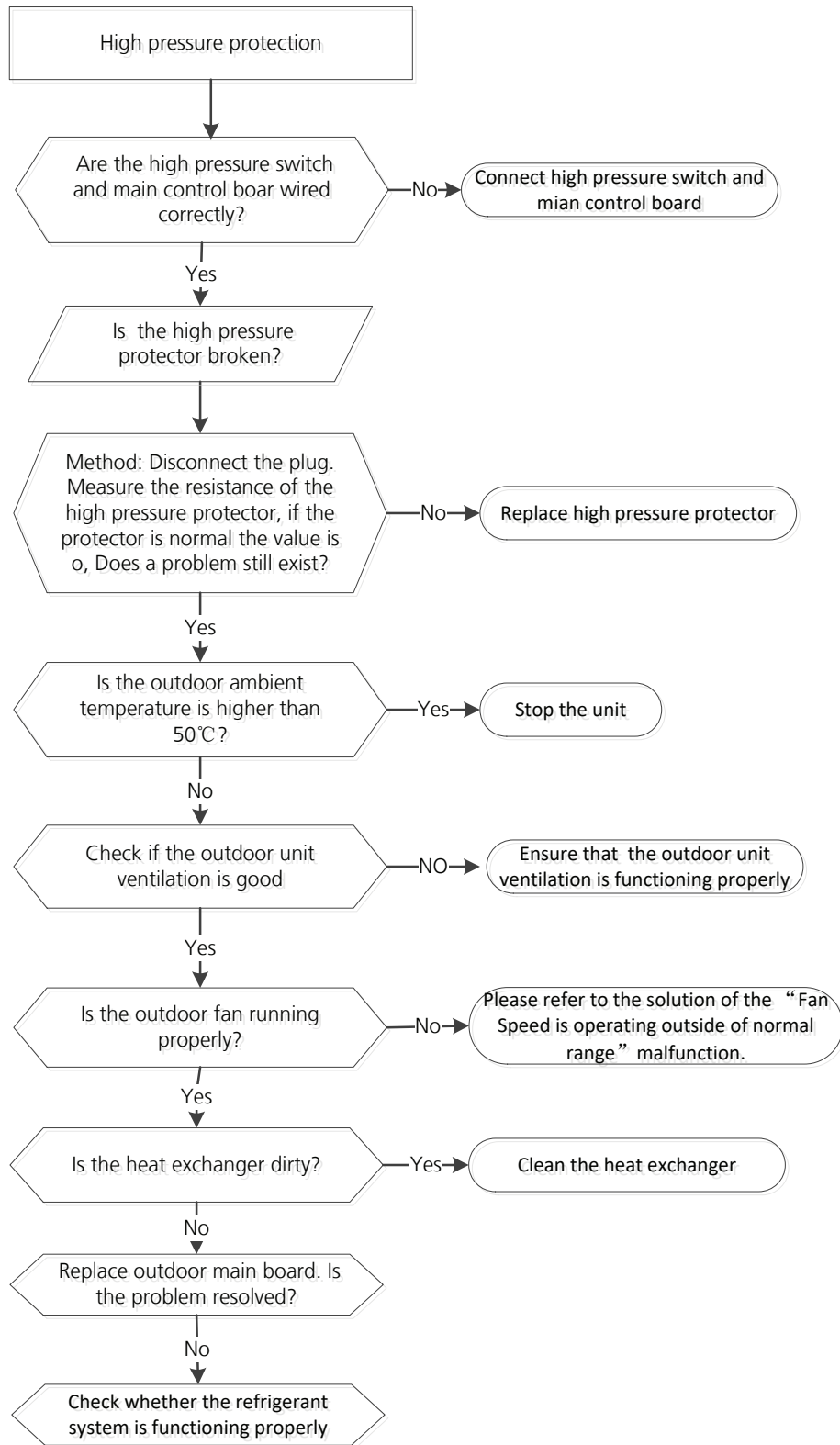

5.14 PC 31 (System low pressure protection diagnosis and solution)

Description: Outdoor pressure switch cut off the system because low pressure is lower than 0.13 MPa, the LED displays the failure code.

Recommended parts to prepare:

- Connection wires
- Outdoor PCB
- Low pressure protector
- Refrigerant

Troubleshooting and repair:

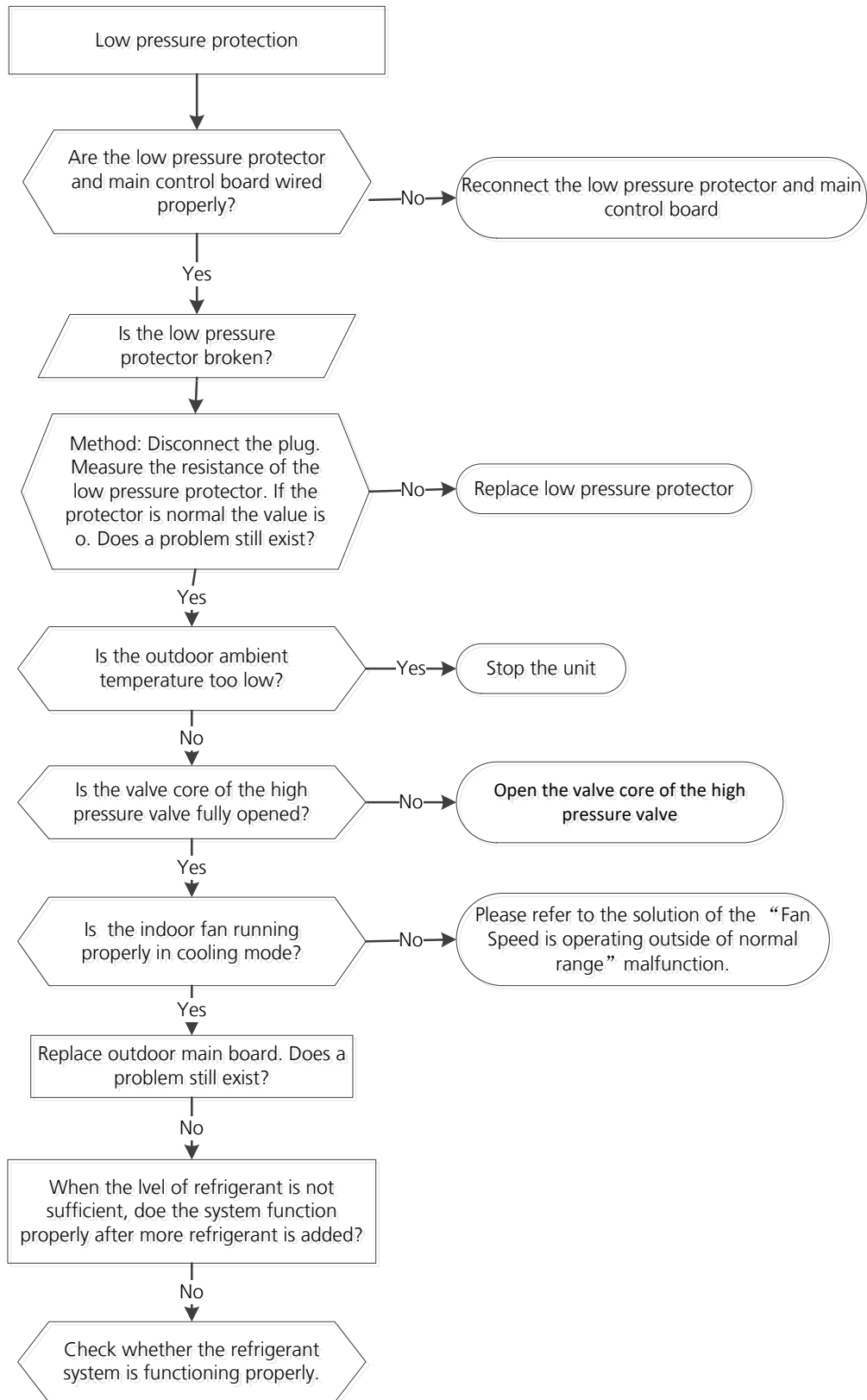

5.15 EC 72 (Lack phase failure of outdoor DC fan motor diagnosis and solution)

Description: When the three-phase sampling current of the DC motor is abnormal, especially when the current of one or more phases is always small and almost 0, the LED displays the failure code.

Recommended parts to prepare:

- Connection wire
- Fan motor
- Outdoor PCB

Troubleshooting and repair:

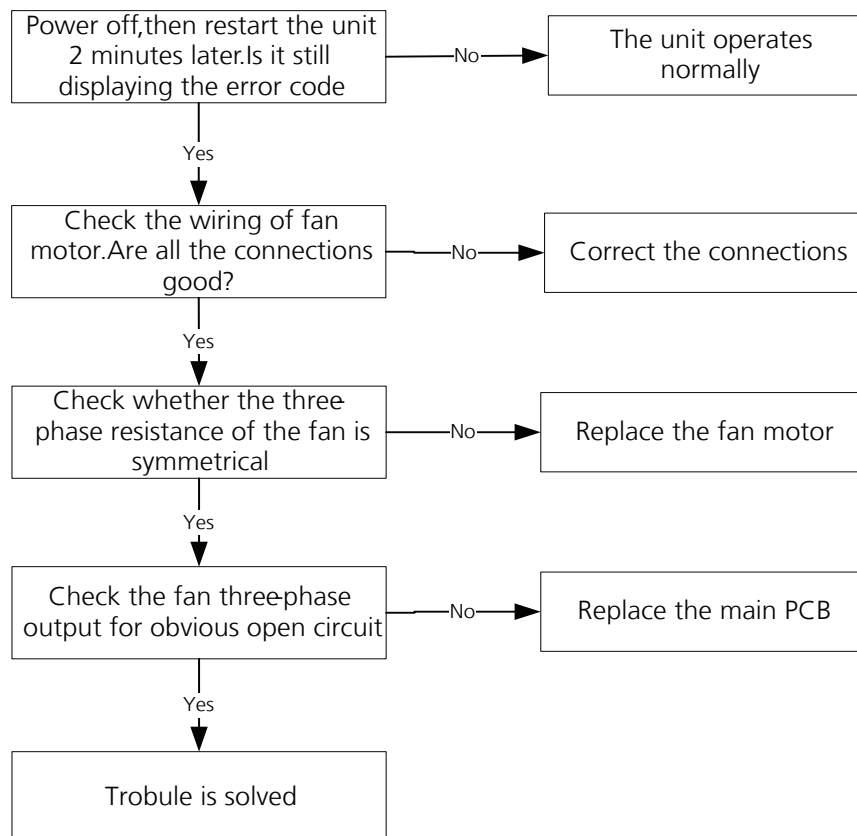

5.16 PC 43 (ODU compressor lack phase protection diagnosis and solution)

Description: When the three-phase sampling current of the compressor is abnormal, especially when the current of one or more phases is always small and almost 0, the LED displays the failure code

Recommended parts to prepare:

- Connection wire
- Compressor
- Outdoor PCB

Troubleshooting and repair:

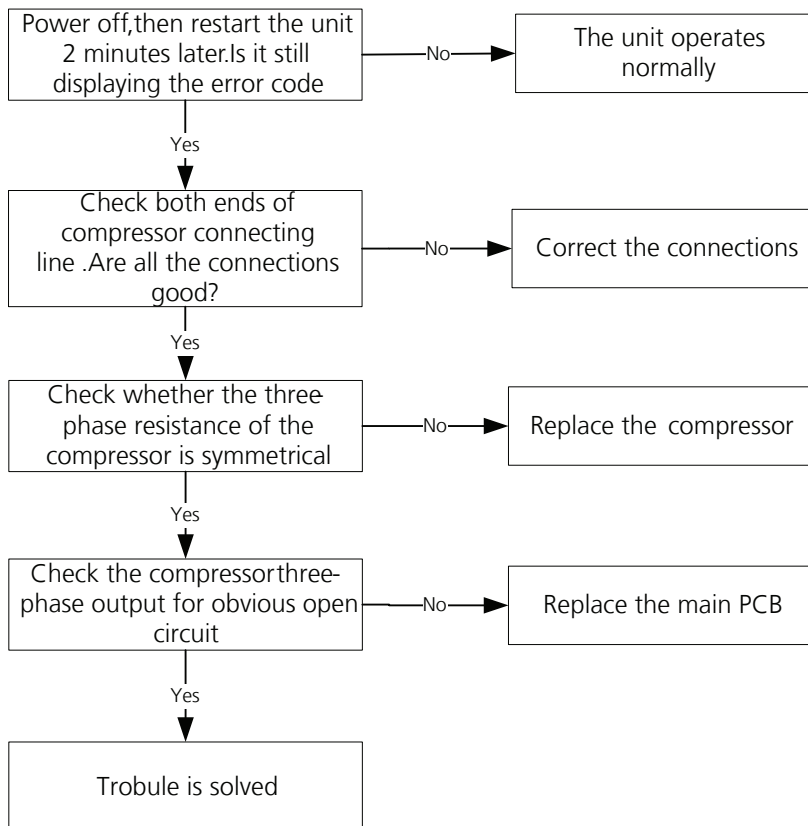

5.17 PC 45 (ODU IR chip drive failure diagnosis and solution)

Description: When the IR chip detects its own parameter error, the LED displays the failure code when power on.

Recommended parts to prepare:

- Inverter module PCB.

Troubleshooting and repair:

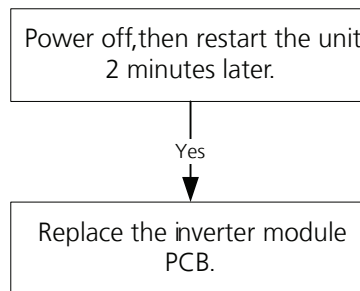

5.18 CE (Automatic correction of wiring/piping error)

Press the "check switch" on the outdoor unit PCB board 5 seconds until LED display "CE", which mean this function is working, Approximately 5-10 minutes after the switch is pressed, the "CE" disappear the wiring/piping error will be corrected, and wiring/piping is properly connected.

5.19 EH C1(Refrigerant sensor detects leakage diagnosis and solution)

Description:

The refrigerant sensor detects a concentration higher than or equal to 10%*LFL for 10 seconds or the refrigerant sensor detects a concentration higher than or equal to 20%*LFL or the multi model receives the refrigerant leakage protection fault sent by the outdoor unit.

Recommended parts to prepare:

- Additional refrigerant

Troubleshooting and repair:

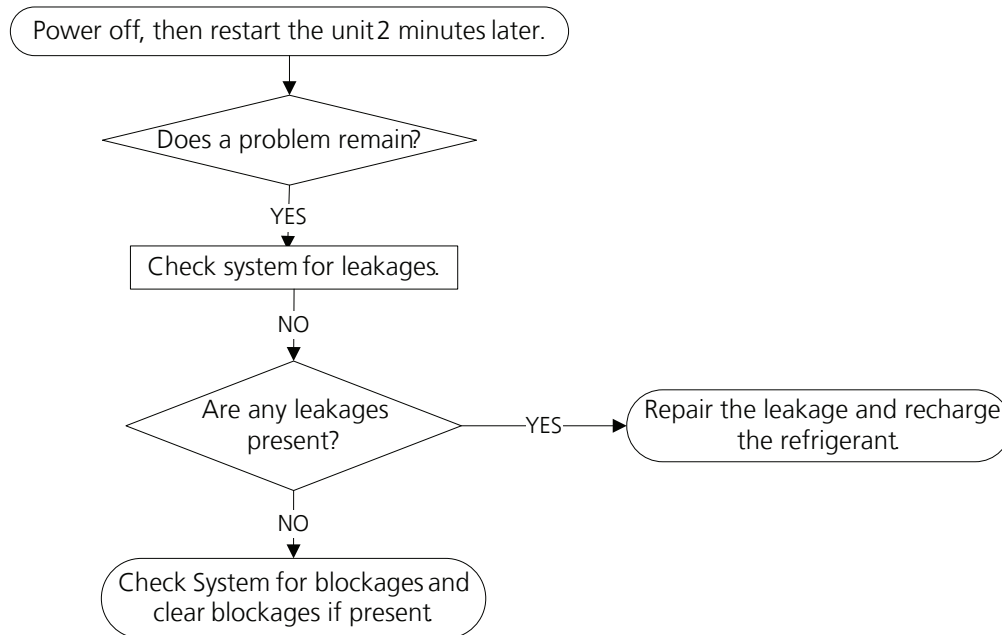

Exit Conditions:

One of the following conditions is met:

1. All connected indoor units have no refrigerant leakage protection signal for more than 2.5 hours;
2. All connected indoor units have no refrigerant leakage protection signal, and receive the signal to clear refrigerant leakage protection (press and hold SW1 on the auxiliary PCB for 10 seconds).
3. The data of EEPROM is protected by refrigerant leakage when the data is read on power-on, and the recovery time of the refrigerant leakage protection is more than 2.5 hours.

5.20 EC 55(ODU IPM module temperature sensor malfunction diagnosis and solution)

Description: If the sampling voltage is 0V or 5V, the LED displays the failure code.

Recommended parts to prepare:

- IPM module PCB
- Connection wires
- Sensors
- Outdoor main PCB

Troubleshooting and repair:

If the radiator has no sensor, follow the steps below to resolve,

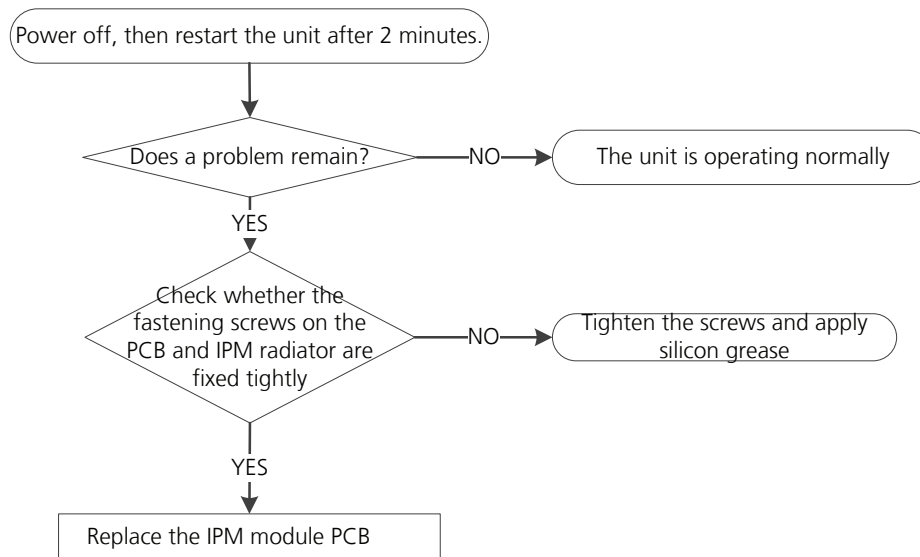

If the radiator has a sensor(TH), follow the steps below to resolve,

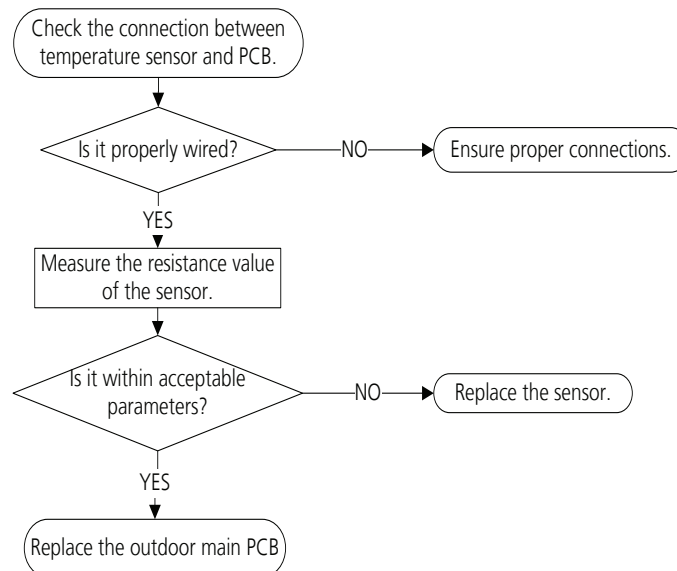

5.21 EC 5C(Pressure sensor failure diagnosis and solution)

Description: If the sampling voltage is lower than 2V or higher than 254V

Recommended parts to prepare:

- Connection wires
- Sensor
- Outdoor PCB

Troubleshooting and repair:

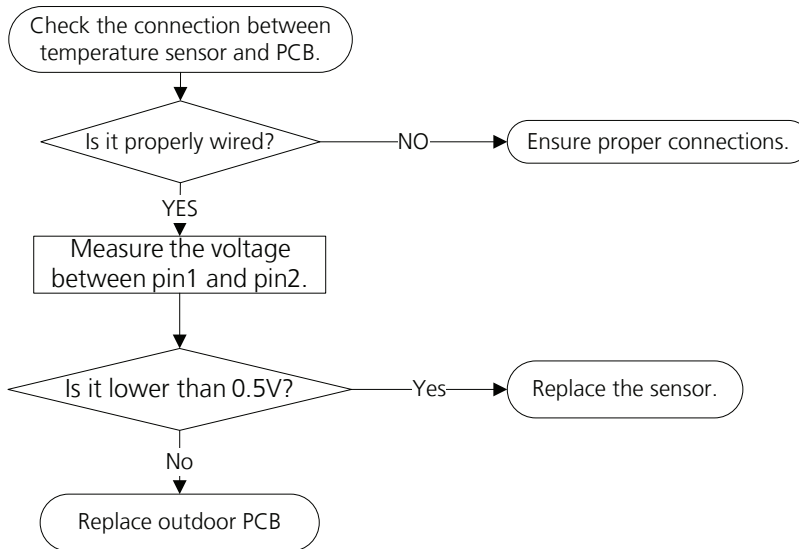

5.22 PC 13(The AC power is cut off or the AC voltage detection circuit fails diagnosis and solution)

Description: The machine equipped with a safety shut-off valve has detected a power outage from the mains.

Recommended parts to prepare:

- Outdoor PCB

Troubleshooting and repair:

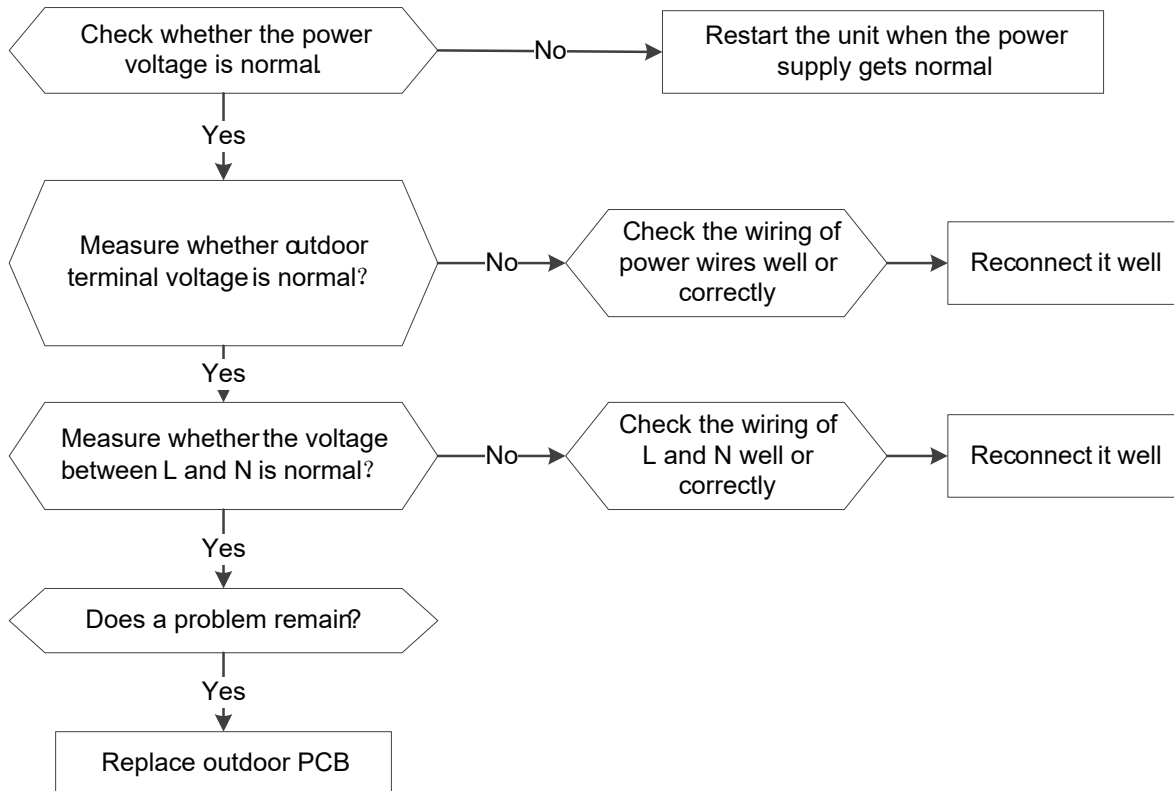

5.23 PC A1(Condensation protection of refrigerant pipe diagnosis and solution)

Description: If outdoor ambient temperature is higher than a certain set value of the refrigerant pipe temperature for a period of time, the LED displays the failure code.

Recommended parts to prepare:

- T4 sensor
- T5 sensor
- Main EXV
- Outdoor PCB

Troubleshooting and repair:

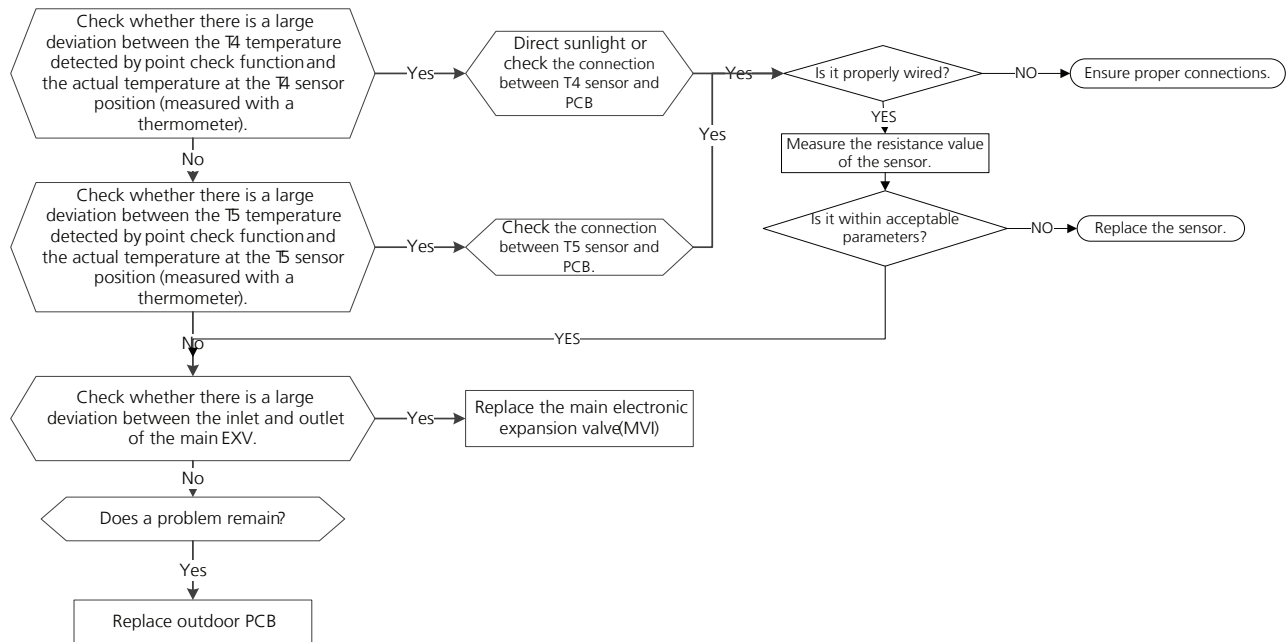

6. Check Procedures

6.1 Temperature Sensor Check

! WARNING

Be sure to turn off all power supplies or disconnect all wires to avoid electric shock. Operate after compressor and coil have returned to normal temperature in case of injury.

1. Disconnect the temperature sensor from PCB (Refer to Chapter 5&6. Indoor&Outdoor Unit Disassembly).
2. Measure the resistance value of the sensor using a multi-meter.
3. Check corresponding temperature sensor resistance value table (Refer to Chapter Appendix).

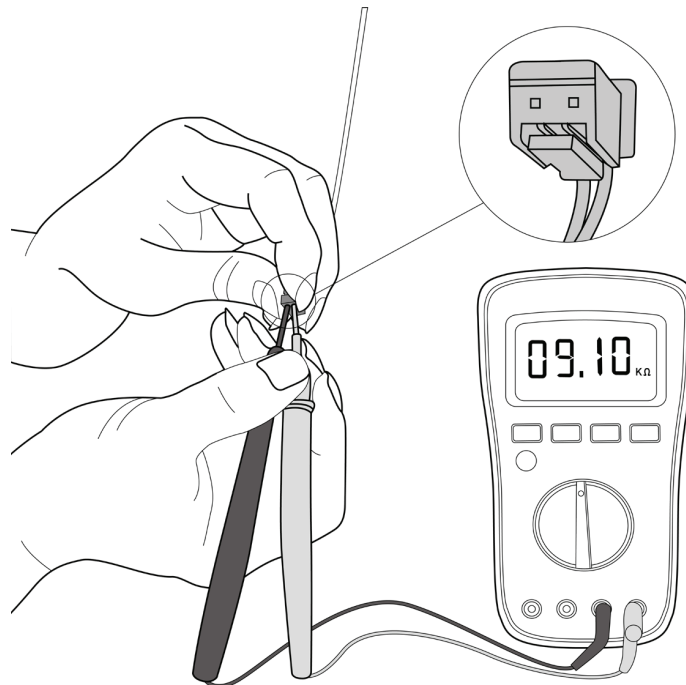

Note: The picture and the value are only for reference, actual condition and specific value may vary.

6.2 Compressor Check

1. Disconnect the compressor power cord from outdoor PCB (Refer to Chapter 6. Outdoor Unit Disassembly)).
2. Measure the resistance value of each winding using a multi-meter.
3. Check the resistance value of each winding in the following table.

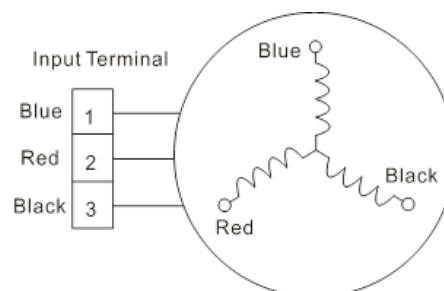

Resistance Value	KSK103D33UEZ3	KSN140D58UFZ	KTF250D22UMT	KTN110D42UFZ	KTF420D62UNT
Blue-Red	2.13Ω	1.86Ω	0.75Ω	1.82Ω	0.86Ω
Blue-Black					
Red-Black					

Resistance Value	KTN150D30UFZA	KTM240D46UKT2	KTF310D43UMT	ETPQ420D1UMUA ETPQ440D1UMUB KTQ420D1UMU EKPQ440D1UMUB	MTH356UKRC8FQL
Blue-Red	1.02Ω	1.04Ω	0.65Ω	0.37Ω	0.487Ω
Blue-Black					
Red-Black					

Resistance Value	MTH550UKPC8FU				
Blue-Red	0.295Ω				
Blue-Black					
Red-Black					

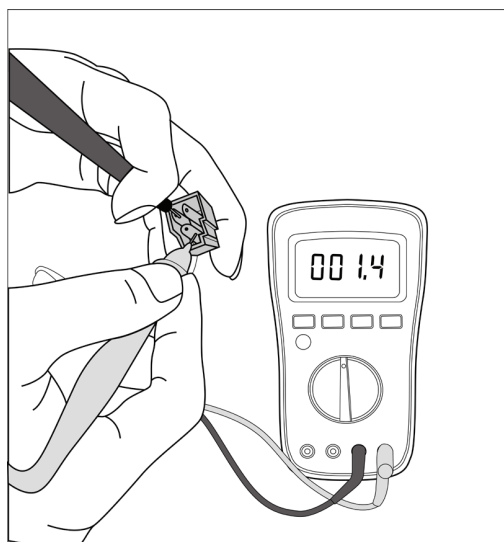

Note: The picture and the value are only for reference, actual condition and specific value may vary.

6.3 IPM Continuity Check

WARNING

**Electricity remains in capacitors even when the power supply is off.
Ensure the capacitors are fully discharged before troubleshooting.**

1. Turn off outdoor unit and disconnect power supply.
2. Discharge electrolytic capacitors and ensure all energy-storage unit has been discharged.
3. Disassemble outdoor PCB or disassemble IPM board.
4. Measure the resistance value between P and U(V, W, N); U(V, W) and N.

Digital tester		Resistance value	Digital tester		Resistance value
(+)Red	(-)Black	∞ (Several MΩ)	(+)Red	(-)Black	∞ (Several MΩ)
P	N		N	U	
	U			V	
	V			W	
	W			-	

Or test the conductivity of IPM with diode mode.

Needle-type Tester		Normal Value	Needle-type Tester		Normal Value
Red	Black		Red	Black	
P	U	Open-circuit	N	U	0.3-0.5V
	V			V	
	W			W	
Needle-type Tester		Normal Value	Needle-type Tester		Normal Value
Black	Red		Black	Red	
P	U	0.3-0.5V	N	U	Open-circuit
	V			V	
	W			W	

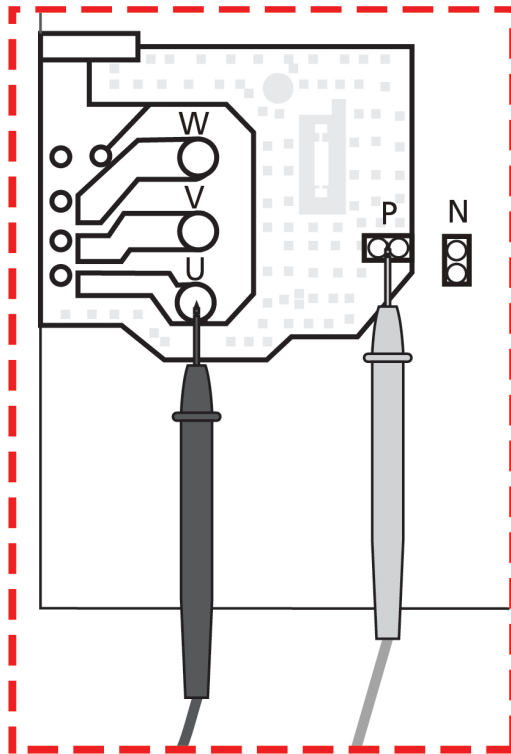

Note: The picture and the value are only for reference, actual condition and specific value may vary.

6.4 Normal voltage of P and N

208-230V(1-phase)		
In standby		
around 310VDC		
In operation		
With passive PFC module	With partial active PFC module	With fully active PFC module
>200VDC	>310VDC	>370VDC

6.5 Reactor Check

Measure the resistance and voltage (to ground) of the reactor. The normal resistance should be around 0.1 ohm. Otherwise, the reactor must have malfunction.

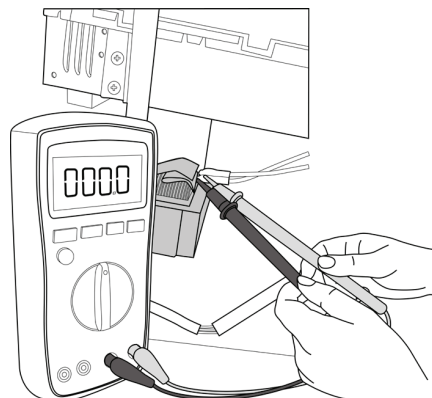

6.6 4-way valve Check

1. Power on, use a digital tester to measure the voltage, when the unit operates in cooling, it is 0V. When the unit operates in heating, it is about equal to power supply voltage.

If the value of the voltage is not in the range, the PCB must have problems and need to be replaced.

2 Turn off the power, use a digital tester to measure the resistance. The value should be 1.8~2.5 K Ω .

6.7 EXV Check

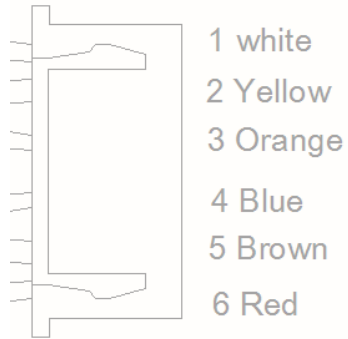

1. Turn off outdoor unit and disconnect power supply.

2. Disconnect the connectors of EXV.

3. Measure the resistance value between Red and Blue(Yellow); Brown and Orange(White).

Resistance to EXV coil

Color of lead wire	Normal Value
Red- Blue	About 50 Ω
Red - Yellow	
Brown-Orange	
Brown-White	

Appendix

Contents

i)	Temperature Sensor Resistance Value Table for TP (°C --K).....	2
ii)	Other Temperature Sensors Resistance Value Table (°C – K).....	3
iii)	System Pressure Table	4

i) Temperature Sensor Resistance Value Table for TP (°C --K)

°C	°F	K Ohm	°C	°F	K Ohm	°C	°F	K Ohm	°C	°F	K Ohm
-20	-4	542.7	20	68	68.66	60	140	13.59	100	212	3.702
-19	-2	511.9	21	70	65.62	61	142	13.11	101	214	3.595
-18	0	483	22	72	62.73	62	144	12.65	102	216	3.492
-17	1	455.9	23	73	59.98	63	145	12.21	103	217	3.392
-16	3	430.5	24	75	57.37	64	147	11.79	104	219	3.296
-15	5	406.7	25	77	54.89	65	149	11.38	105	221	3.203
-14	7	384.3	26	79	52.53	66	151	10.99	106	223	3.113
-13	9	363.3	27	81	50.28	67	153	10.61	107	225	3.025
-12	10	343.6	28	82	48.14	68	154	10.25	108	226	2.941
-11	12	325.1	29	84	46.11	69	156	9.902	109	228	2.86
-10	14	307.7	30	86	44.17	70	158	9.569	110	230	2.781
-9	16	291.3	31	88	42.33	71	160	9.248	111	232	2.704
-8	18	275.9	32	90	40.57	72	162	8.94	112	234	2.63
-7	19	261.4	33	91	38.89	73	163	8.643	113	235	2.559
-6	21	247.8	34	93	37.3	74	165	8.358	114	237	2.489
-5	23	234.9	35	95	35.78	75	167	8.084	115	239	2.422
-4	25	222.8	36	97	34.32	76	169	7.82	116	241	2.357
-3	27	211.4	37	99	32.94	77	171	7.566	117	243	2.294
-2	28	200.7	38	100	31.62	78	172	7.321	118	244	2.233
-1	30	190.5	39	102	30.36	79	174	7.086	119	246	2.174
0	32	180.9	40	104	29.15	80	176	6.859	120	248	2.117
1	34	171.9	41	106	28	81	178	6.641	121	250	2.061
2	36	163.3	42	108	26.9	82	180	6.43	122	252	2.007
3	37	155.2	43	109	25.86	83	181	6.228	123	253	1.955
4	39	147.6	44	111	24.85	84	183	6.033	124	255	1.905
5	41	140.4	45	113	23.89	85	185	5.844	125	257	1.856
6	43	133.5	46	115	22.89	86	187	5.663	126	259	1.808
7	45	127.1	47	117	22.1	87	189	5.488	127	261	1.762
8	46	121	48	118	21.26	88	190	5.32	128	262	1.717
9	48	115.2	49	120	20.46	89	192	5.157	129	264	1.674
10	50	109.8	50	122	19.69	90	194	5	130	266	1.632
11	52	104.6	51	124	18.96	91	196	4.849			
12	54	99.69	52	126	18.26	92	198	4.703			
13	55	95.05	53	127	17.58	93	199	4.562			
14	57	90.66	54	129	16.94	94	201	4.426			
15	59	86.49	55	131	16.32	95	203	4.294			
16	61	82.54	56	133	15.73	96	205	4.167			
17	63	78.79	57	135	15.16	97	207	4.045			
18	64	75.24	58	136	14.62	98	208	3.927			
19	66	71.86	59	138	14.09	99	210	3.812			

ii) Other Temperature Sensors Resistance Value Table (°C – K)

°C	°F	K Ohm	°C	°F	K Ohm	°C	°F	K Ohm	°C	°F	K Ohm
-20	-4	115.266	20	68	12.6431	60	140	2.35774	100	212	0.62973
-19	-2	108.146	21	70	12.0561	61	142	2.27249	101	214	0.61148
-18	0	101.517	22	72	11.5	62	144	2.19073	102	216	0.59386
-17	1	96.3423	23	73	10.9731	63	145	2.11241	103	217	0.57683
-16	3	89.5865	24	75	10.4736	64	147	2.03732	104	219	0.56038
-15	5	84.219	25	77	10	65	149	1.96532	105	221	0.54448
-14	7	79.311	26	79	9.55074	66	151	1.89627	106	223	0.52912
-13	9	74.536	27	81	9.12445	67	153	1.83003	107	225	0.51426
-12	10	70.1698	28	82	8.71983	68	154	1.76647	108	226	0.49989
-11	12	66.0898	29	84	8.33566	69	156	1.70547	109	228	0.486
-10	14	62.2756	30	86	7.97078	70	158	1.64691	110	230	0.47256
-9	16	58.7079	31	88	7.62411	71	160	1.59068	111	232	0.45957
-8	18	56.3694	32	90	7.29464	72	162	1.53668	112	234	0.44699
-7	19	52.2438	33	91	6.98142	73	163	1.48481	113	235	0.43482
-6	21	49.3161	34	93	6.68355	74	165	1.43498	114	237	0.42304
-5	23	46.5725	35	95	6.40021	75	167	1.38703	115	239	0.41164
-4	25	44	36	97	6.13059	76	169	1.34105	116	241	0.4006
-3	27	41.5878	37	99	5.87359	77	171	1.29078	117	243	0.38991
-2	28	39.8239	38	100	5.62961	78	172	1.25423	118	244	0.37956
-1	30	37.1988	39	102	5.39689	79	174	1.2133	119	246	0.36954
0	32	35.2024	40	104	5.17519	80	176	1.17393	120	248	0.35982
1	34	33.3269	41	106	4.96392	81	178	1.13604	121	250	0.35042
2	36	31.5635	42	108	4.76253	82	180	1.09958	122	252	0.3413
3	37	29.9058	43	109	4.5705	83	181	1.06448	123	253	0.33246
4	39	28.3459	44	111	4.38736	84	183	1.03069	124	255	0.3239
5	41	26.8778	45	113	4.21263	85	185	0.99815	125	257	0.31559
6	43	25.4954	46	115	4.04589	86	187	0.96681	126	259	0.30754
7	45	24.1932	47	117	3.88673	87	189	0.93662	127	261	0.29974
8	46	22.5662	48	118	3.73476	88	190	0.90753	128	262	0.29216
9	48	21.8094	49	120	3.58962	89	192	0.8795	129	264	0.28482
10	50	20.7184	50	122	3.45097	90	194	0.85248	130	266	0.2777
11	52	19.6891	51	124	3.31847	91	196	0.82643	131	268	0.27078
12	54	18.7177	52	126	3.19183	92	198	0.80132	132	270	0.26408
13	55	17.8005	53	127	3.07075	93	199	0.77709	133	271	0.25757
14	57	16.9341	54	129	2.95896	94	201	0.75373	134	273	0.25125
15	59	16.1156	55	131	2.84421	95	203	0.73119	135	275	0.24512
16	61	15.3418	56	133	2.73823	96	205	0.70944	136	277	0.23916
17	63	14.6181	57	135	2.63682	97	207	0.68844	137	279	0.23338
18	64	13.918	58	136	2.53973	98	208	0.66818	138	280	0.22776
19	66	13.2631	59	138	2.44677	99	210	0.64862	139	282	0.22231

iii) System Pressure Table-R454B

Pressure			Temperature		Pressure			Temperature	
Kpa	bar	PSI	°C	°F	Kpa	bar	PSI	°C	°F
58.196	0.58	8.44	-60	-76	935.23	9.35	135.64	8	46.4
61.517	0.62	8.92	-59	-74.2	963.75	9.64	139.78	9	48.2
64.988	0.65	9.43	-58	-72.4	992.93	9.93	144.01	10	50
68.615	0.69	9.95	-57	-70.6	1022.8	10.23	148.34	11	51.8
72.402	0.72	10.50	-56	-68.8	1053.3	10.53	152.76	12	53.6
76.354	0.76	11.07	-55	-67	1084.5	10.85	157.29	13	55.4
80.478	0.80	11.67	-54	-65.2	1116.4	11.16	161.91	14	57.2
84.776	0.85	12.30	-53	-63.4	1149	11.49	166.64	15	59
89.256	0.89	12.95	-52	-61.6	1182.3	11.82	171.47	16	60.8
93.923	0.94	13.62	-51	-59.8	1216.3	12.16	176.40	17	62.6
98.781	0.99	14.33	-50	-58	1251.1	12.51	181.45	18	64.4
103.84	1.04	15.06	-49	-56.2	1286.6	12.87	186.60	19	66.2
109.1	1.09	15.82	-48	-54.4	1322.8	13.23	191.85	20	68
114.56	1.15	16.61	-47	-52.6	1359.9	13.60	197.23	21	69.8
120.25	1.20	17.44	-46	-50.8	1397.7	13.98	202.71	22	71.6
126.15	1.26	18.30	-45	-49	1436.3	14.36	208.31	23	73.4
132.28	1.32	19.18	-44	-47.2	1475.7	14.76	214.02	24	75.2
138.64	1.39	20.11	-43	-45.4	1515.9	15.16	219.85	25	77
145.24	1.45	21.06	-42	-43.6	1557	15.57	225.82	26	78.8
152.09	1.52	22.06	-41	-41.8	1598.9	15.99	231.89	27	80.6
159.18	1.59	23.09	-40	-40	1641.6	16.42	238.09	28	82.4
166.54	1.67	24.15	-39	-38.2	1685.2	16.85	244.41	29	84.2
174.15	1.74	25.26	-38	-36.4	1729.7	17.30	250.86	30	86
182.04	1.82	26.40	-37	-34.6	1775	17.75	257.43	31	87.8
190.2	1.90	27.59	-36	-32.8	1821.3	18.21	264.15	32	89.6
198.65	1.99	28.81	-35	-31	1868.4	18.68	270.98	33	91.4
207.39	2.07	30.08	-34	-29.2	1916.5	19.17	277.95	34	93.2
216.42	2.16	31.39	-33	-27.4	1965.6	19.66	285.08	35	95
225.76	2.26	32.74	-32	-25.6	2015.5	20.16	292.31	36	96.8
235.41	2.35	34.14	-31	-23.8	2066.5	20.67	299.71	37	98.6
245.37	2.45	35.59	-30	-22	2118.4	21.18	307.24	38	100.4
255.67	2.56	37.08	-29	-20.2	2171.3	21.71	314.91	39	102.2
266.29	2.66	38.62	-28	-18.4	2225.2	22.25	322.73	40	104
277.25	2.77	40.21	-27	-16.6	2280.2	22.80	330.70	41	105.8
288.56	2.89	41.85	-26	-14.8	2336.1	23.36	338.81	42	107.6
300.22	3.00	43.54	-25	-13	2393.2	23.93	347.09	43	109.4
312.24	3.12	45.28	-24	-11.2	2451.3	24.51	355.52	44	111.2
324.63	3.25	47.08	-23	-9.4	2510.4	25.10	364.09	45	113
337.39	3.37	48.93	-22	-7.6	2570.7	25.71	372.84	46	114.8
350.54	3.51	50.84	-21	-5.8	2632.1	26.32	381.74	47	116.6
364.08	3.64	52.80	-20	-4	2694.7	26.95	390.82	48	118.4
378.02	3.78	54.83	-19	-2.2	2758.3	27.58	400.04	49	120.2
392.37	3.92	56.91	-18	-0.4	2823.2	28.23	409.46	50	122
407.13	4.07	59.05	-17	1.4	2889.3	28.89	419.04	51	123.8

422.31	4.22	61.25	-16	3.2	2956.5	29.57	428.79	52	125.6
437.92	4.38	63.51	-15	5	3025	30.25	438.72	53	127.4
453.98	4.54	65.84	-14	6.8	3094.7	30.95	448.83	54	129.2
470.47	4.70	68.23	-13	8.6	3165.7	31.66	459.13	55	131
487.43	4.87	70.69	-12	10.4	3238.1	32.38	469.63	56	132.8
504.84	5.05	73.22	-11	12.2	3311.7	33.12	480.30	57	134.6
522.73	5.23	75.81	-10	14	3386.7	33.87	491.18	58	136.4
541.1	5.41	78.48	-9	15.8	3463	34.63	502.25	59	138.2
559.95	5.60	81.21	-8	17.6	3540.7	35.41	513.52	60	140
579.31	5.79	84.02	-7	19.4	3619.9	36.20	525.00	61	141.8
599.16	5.99	86.90	-6	21.2	3700.5	37.01	536.69	62	143.6
619.54	6.20	89.85	-5	23	3782.7	37.83	548.61	63	145.4
640.43	6.40	92.88	-4	24.8	3866.3	38.66	560.74	64	147.2
661.86	6.62	95.99	-3	26.6	3951.5	39.52	573.10	65	149
683.82	6.84	99.18	-2	28.4	4038.3	40.38	585.69	66	150.8
706.34	7.06	102.44	-1	30.2	4126.8	41.27	598.52	67	152.6
729.41	7.29	105.79	0	32	4217	42.17	611.60	68	154.4
753.06	7.53	109.22	1	33.8	4309	43.09	624.95	69	156.2
777.28	7.77	112.73	2	35.6	4402.9	44.03	638.56	70	158
802.08	8.02	116.33	3	37.4	4498.7	44.99	652.46	71	159.8
827.48	8.27	120.01	4	39.2	4596.5	45.97	666.64	72	161.6
853.49	8.53	123.78	5	41	4696.5	46.97	681.15	73	163.4
880.11	8.80	127.64	6	42.8	4798.9	47.99	696.00	74	165.2
907.35	9.07	131.60	7	44.6	4904.1	49.04	711.25	75	167

Due to ongoing product improvements, specifications and dimensions are subject to change and correction without notice or incurring obligations. Determining the application and suitability for use of any product is the responsibility of the installer. Additionally, the installer is responsible for verifying dimensional data on the actual product prior to beginning any installation preparations.

Incentive and rebate programs have precise requirements as to product performance and certification. All products meet applicable regulations in effect on date of manufacture; however, certifications are not necessarily granted for the life of a product. Therefore, it is the responsibility of the applicant to determine whether a specific model qualifies for these incentive/rebate programs.



1900 Wellworth Ave., Jackson, MI 49203 • Ph. 517-787-2100 • www.heatcontroller.com