Comfort-Aire®

Century®

Service Manual

VMH-SV Series
Single-Zone Mini-Splits

Model

VMH06, 09, 12, 18, 24 SV Series

Table of Contents

§. Safety Precautions

1. Precautions
2. Information servicing(For flammable materials)

§. Specifications

1. Model Reference
2. Pipe length and the Drop Height
3. Electrical Wiring Diagrams

§. Product Features

1. Display Function[?]
2. Safety Features
3. Basic Features

§. Maintenance

1. First Time Installation Check[?]
2. Refrigerant Recharge
3. Re-Installation

§. Indoor Unit Disassembly

1. Dimension[?]
2. Indoor Unit Disassembly

§. Outdoor Unit Disassembly

1. Outdoor Unit Table
2. Dimension[?]
3. Outdoor Unit Disassembly

Table of Contents

§. Troubleshooting

1. Safety Caution
2. General Troubleshooting
3. Complain Record Form
4. Information Inquiry
5. Error Diagnosis and Troubleshooting Without Error Code
6. Quick Maintenance by Error Code
7. Troubleshooting by Error Code
8. Check Procedures

Appendix

- i) Temperature Sensor Resistance Value Table for T1,T2,T3 and T4 (°C – K)
- ii) Temperature Sensor Resistance Value Table for TP(for some units) (°C – K)
- iii) Pressure On Service Port

Safety Precautions

Contents

1.	Precautions.....	2
2.	Information servicing(For flammable materials).....	3

1. Precautions

To prevent personal injury, or property or unit damage, adhere to all precautionary measures and instructions outlined in this manual. Before servicing a unit, refer to this service manual and its relevant sections.

Failure to adhere to all precautionary measures listed in this section may result in personal injury, damage to the unit or to property, or in extreme cases, death.

 **WARNING** indicates a potentially hazardous situation which if not avoided could result in serious personal injury, or death.

 **CAUTION** indicates a potentially hazardous situation which if not avoided could result in minor or moderate personal injury, or unit damage.

1.1 In case of Accidents or Emergency

WARNING

- If a gas leak is suspected, immediately turn off the gas and ventilate the area if a gas leak is suspected before turning the unit on.
- If strange sounds or smoke is detected from the unit, turn the breaker off and disconnect the power supply cable.
- If the unit comes into contact with liquid, contact an authorized service center.
- If liquid from the batteries makes contact with skin or clothing, immediately rinse or wash the area well with clean water.
- Do not insert hands or other objects into the air inlet or outlet while the unit is plugged in.
- Do not operate the unit with wet hands.
- Do not use a remote controller that has previously been exposed to battery damage or battery leakage.

CAUTION

- Clean and ventilate the unit at regular intervals when operating it near a stove or near similar devices.
- Do not use the unit during severe weather conditions. If possible, remove the product from the window before such occurrences.

1.2 Pre-Installation and Installation

WARNING

- Use this unit only on a dedicated circuit.
- Damage to the installation area could cause the unit to fall, potentially resulting in personal injury, property damage, or product failure.
- Only qualified personnel should disassemble, install, remove, or repair the unit.
- Only a qualified electrician should perform electrical work. For more information, contact your dealer, seller, or an authorized service center.

CAUTION

- While unpacking be careful of sharp edges around the unit as well as the edges of the fins on the condenser and evaporator.

1.3 Operation and Maintenance

WARNING

- Do not use defective or under-rated circuit breakers.
- Ensure the unit is properly grounded and that a dedicated circuit and breaker are installed.
- Do not modify or extend the power cable. Ensure the power cable is secure and not damaged during operation.
- Do not unplug the power supply plug during operation.
- Do not store or use flammable materials near the unit.
- Do not open the inlet grill of the unit during operation.
- Do not touch the electrostatic filter if the unit is equipped with one.
- Do not block the inlet or outlet of air flow to the unit.
- Do not use harsh detergents, solvents, or similar items to clean the unit. Use a soft cloth for cleaning.
- Do not touch the metal parts of the unit when removing the air filter as they are very sharp.
- Do not step on or place anything on the unit or outdoor units.
- Do not drink water drained from the unit
- Avoid direct skin contact with water drained from the unit.
- Use a firm stool or step ladder according to manufacturer procedures when cleaning or maintaining the unit.

CAUTION

- Do not install or operate the unit for an extended period of time in areas of high humidity or in an environment directly exposing it to sea wind or salt spray.
- Do not install the unit on a defective or damaged installation stand, or in an unsecure location.
- Ensure the unit is installed at a level position
- Do not install the unit where noise or air discharge created by the outdoor unit will negatively impact the environment or nearby residences.
- Do not expose skin directly to the air discharged by the unit for prolonged periods of time.
- Ensure the unit operates in areas water or other liquids.
- Ensure the drain hose is installed correctly to ensure proper water drainage.
- When lifting or transporting the unit, it is recommended that two or more people are used for this task.
- When the unit is not to be used for an extended time, disconnect the power supply or turn off the breaker.

2. Information servicing(For flammable materials)

2.1 Checks to the area

- Prior to beginning work on systems containing flammable refrigerants, safety checks are necessary to ensure that the risk of ignition is minimized.
- For repair to the refrigerating system, the following precautions shall be complied with prior to conducting work on the system.

2.2 Work procedure

- Work shall be undertaken under a controlled procedure so as to minimise the risk of a flammable gas or vapour being present while the work is being performed.

2.3 Work procedure

- All maintenance staff and others working in the local area shall be instructed on the nature of work being carried out.
- Work in confined spaces shall be avoided.
- The area around the work space shall be sectioned off. Ensure that the conditions within the area have been made safe by control of flammable material.

2.4 Checking for presence of refrigerant

- The area shall be checked with an appropriate refrigerant detector prior to and during work, to ensure the technician is aware of potentially flammable atmospheres.
- Ensure that the leak detection equipment being used is suitable for use with flammable refrigerants, i.e. no sparking, adequately sealed or intrinsically safe.

2.5 Presence of fire extinguisher

- If any hot work is to be conducted on the refrigeration equipment or any associated parts, appropriate fire extinguishing equipment shall be available to hand.
- Have a dry powder or CO₂ fire extinguisher adjacent to the charging area.

2.6 No ignition sources

- No person carrying out work in relation to a refrigeration system which involves exposing any pipe work that contains or has contained flammable refrigerant shall use any sources of ignition in such a manner that it may lead to the risk of fire or explosion.
- All possible ignition sources, including cigarette smoking, should be kept sufficiently far away from the site of installation, repairing, removing and disposal, during which flammable refrigerant can possibly be released to the surrounding space.

- Prior to work taking place, the area around the equipment is to be surveyed to make sure that there are no flammable hazards or ignition risks.
- NO SMOKING signs shall be displayed.

2.7 Ventilated area

- Ensure that the area is in the open or that it is adequately ventilated before breaking into the system or conducting any hot work. A degree of ventilation shall continue during the period that the work is carried out. The ventilation should safely disperse any released refrigerant and preferably expel it externally into the atmosphere.

2.8 Checks to the refrigeration equipment

- Where electrical components are being changed, they shall be fit for the purpose and to the correct specification. At all times the manufacturer's maintenance and service guidelines shall be followed. If in doubt consult the manufacturer's technical department for assistance. The following checks shall be applied to installations using flammable refrigerants:
 - the charge size is in accordance with the room size within which the refrigerant containing parts are installed;
 - the ventilation machinery and outlets are operating adequately and are not obstructed;
 - if an indirect refrigerating circuit is being used, the secondary circuit shall be checked for the presence of refrigerant; marking to the equipment continues to be visible and legible.
 - markings and signs that are illegible shall be corrected;
 - refrigeration pipe or components are installed in a position where they are unlikely to be exposed to any substance which may corrode refrigerant containing components, unless the components are constructed of materials which are inherently resistant to being corroded or are suitably protected against being so corroded.

2.9 Checks to electrical devices

- Repair and maintenance to electrical components shall include initial safety checks and component inspection procedures. If a fault exists that could compromise safety, then no electrical supply shall be connected to the circuit until it is satisfactorily dealt with. If the fault cannot be corrected immediately but it is necessary to continue operation, an adequate temporary solution shall be used. This shall be reported to the owner of the equipment so all parties are advised. Initial safety checks shall include:

- that capacitors are discharged: this shall be done in a safe manner to avoid possibility of sparking;
- that there no live electrical components and wiring are exposed while charging, recovering or purging the system;
- that there is continuity of earth bonding.

2.10 Repairs to sealed components

- During repairs to sealed components, all electrical supplies shall be disconnected from the equipment being worked upon prior to any removal of sealed covers, etc. If it is absolutely necessary to have an electrical supply to equipment during servicing, then a permanently operating form of leak detection shall be located at the most critical point to warn of a potentially hazardous situation.
- Particular attention shall be paid to the following to ensure that by working on electrical components, the casing is not altered in such a way that the level of protection is affected. This shall include damage to cables, excessive number of connections, terminals not made to original specification, damage to seals, incorrect fitting of glands, etc.
 - Ensure that apparatus is mounted securely.
 - Ensure that seals or sealing materials have not degraded such that they no longer serve the purpose of preventing the ingress of flammable atmospheres. Replacement parts shall be in accordance with the manufacturer's specifications.

NOTE: The use of silicon sealant may inhibit the effectiveness of some types of leak detection equipment. Intrinsically safe components do not have to be isolated prior to working on them.

2.11 Repair to intrinsically safe components

- Do not apply any permanent inductive or capacitance loads to the circuit without ensuring that this will not exceed the permissible voltage and current permitted for the equipment in use. Intrinsically safe components are the only types that can be worked on while live in the presence of a flammable atmosphere. The test apparatus shall be at the correct rating.
- Replace components only with parts specified by the manufacturer. Other parts may result in the ignition of refrigerant in the atmosphere from a leak.

2.12 Cabling

- Check that cabling will not be subject to wear, corrosion, excessive pressure, vibration, sharp edges or any other adverse environmental effects. The check

shall also take into account the effects of aging or continual vibration from sources such as compressors or fans.

2.13 Detection of flammable refrigerants

- Under no circumstances shall potential sources of ignition be used in the searching for or detection of refrigerant leaks. A halide torch (or any other detector using a naked flame) shall not be used.

2.14 Leak detection methods

- The following leak detection methods are deemed acceptable for systems containing flammable refrigerants. Electronic leak detectors shall be used to detect flammable refrigerants, but the sensitivity may not be adequate, or may need re-calibration. (Detection equipment shall be calibrated in a refrigerant-free area.) Ensure that the detector is not a potential source of ignition and is suitable for the refrigerant used. Leak detection equipment shall be set at a percentage of the LFL of the refrigerant and shall be calibrated to the refrigerant employed and the appropriate percentage of gas (25 % maximum) is confirmed. Leak detection fluids are suitable for use with most refrigerants but the use of detergents containing chlorine shall be avoided as the chlorine may react with the refrigerant and corrode the copper pipe-work.
 - If a leak is suspected, all naked flames shall be removed or extinguished.
 - If a leakage of refrigerant is found which requires brazing, all of the refrigerant shall be recovered from the system, or isolated (by means of shut off valves) in a part of the system remote from the leak. Oxygen free nitrogen (OFN) shall then be purged through the system both before and during the brazing process.

2.15 Removal and evacuation

- When breaking into the refrigerant circuit to make repairs or for any other purpose, conventional procedures shall be used. However, it is important that best practice is followed since flammability is a consideration.
- The following procedure shall be adhered to:
 - remove refrigerant;
 - purge the circuit with inert gas;
 - evacuate;
 - purge again with inert gas;
 - open the circuit by cutting or brazing.

- The refrigerant charge shall be recovered into the correct recovery cylinders. The system shall be flushed with OFN to render the unit safe. This process may need to be repeated several times. Compressed air or oxygen shall not be used for this task. Flushing shall be achieved by breaking the vacuum in the system with OFN and continuing to fill until the working pressure is achieved, then venting to atmosphere, and finally pulling down to a vacuum. This process shall be repeated until no refrigerant is within the system. When the final OFN charge is used, the system shall be vented down to atmospheric pressure to enable work to take place. This operation is absolutely vital if brazing operations on the pipe-work are to take place.
- Ensure that the outlet for the vacuum pump is not close to any ignition sources and there is ventilation available.

2.16 Charging procedures

- In addition to conventional charging procedures, the following requirements shall be followed:
 - Ensure that contamination of different refrigerants does not occur when using charging equipment. Hoses or lines shall be as short as possible to minimize the amount of refrigerant contained in them.
 - Cylinders shall be kept upright.
 - Ensure that the refrigeration system is earthed prior to charging the system with refrigerant.
 - Label the system when charging is complete (if not already).
 - Extreme care shall be taken not to overfill the refrigeration system.
 - Prior to recharging the system it shall be pressure tested with OFN. The system shall be leak tested on completion of charging but prior to commissioning. A follow up leak test shall be carried out prior to leaving the site.

2.17 Decommissioning

Before carrying out this procedure, it is essential that the technician is completely familiar with the equipment and all its detail. It is recommended good practice that all refrigerants are recovered safely. Prior to the task being carried out, an oil and refrigerant sample shall be taken.

In case analysis is required prior to re-use of reclaimed refrigerant. It is essential that electrical power is available before the task is commenced.

- Become familiar with the equipment and its operation.
- Isolate system electrically.

- Before attempting the procedure ensure that:
 - mechanical handling equipment is available, if required, for handling refrigerant cylinders;
 - all personal protective equipment is available and being used correctly;
 - the recovery process is supervised at all times by a competent person;
 - recovery equipment and cylinders conform to the appropriate standards.
- Pump down refrigerant system, if possible.
- If a vacuum is not possible, make a manifold so that refrigerant can be removed from various parts of the system.
- Make sure that cylinder is situated on the scales before recovery takes place.
- Start the recovery machine and operate in accordance with manufacturer's instructions.
- Do not overfill cylinders. (No more than 80 % volume liquid charge).
- Do not exceed the maximum working pressure of the cylinder, even temporarily.
- When the cylinders have been filled correctly and the process completed, make sure that the cylinders and the equipment are removed from site promptly and all isolation valves on the equipment are closed off.
- Recovered refrigerant shall not be charged into another refrigeration system unless it has been cleaned and checked.

2.18 Labelling

- Equipment shall be labelled stating that it has been de-commissioned and emptied of
- refrigerant. The label shall be dated and signed. Ensure that there are labels on the equipment stating the equipment contains flammable refrigerant.

2.19 Recovery

- When removing refrigerant from a system, either for servicing or decommissioning, it is recommended good practice that all refrigerants are removed safely.
- When transferring refrigerant into cylinders, ensure that only appropriate refrigerant recovery cylinders are employed. Ensure that the correct numbers of cylinders for holding the total system charge are available. All cylinders to be used are designated for the recovered refrigerant and labelled for that refrigerant (i.e. special cylinders for the recovery of refrigerant). Cylinders shall be complete with pressure relief valve and associated shut-off valves in good working order.

-
- Empty recovery cylinders are evacuated and, if possible, cooled before recovery occurs.
 - The recovery equipment shall be in good working order with a set of instructions concerning the equipment that is at hand and shall be suitable for the recovery of flammable refrigerants. In addition, a set of calibrated weighing scales shall be available and in good working order.
 - Hoses shall be complete with leak-free disconnect couplings and in good condition. Before using the recovery machine, check that it is in satisfactory working order, has been properly maintained and that any associated electrical components are sealed to prevent ignition in the event of a refrigerant release. Consult manufacturer if in doubt.
 - The recovered refrigerant shall be returned to the refrigerant supplier in the correct recovery cylinder, and the relevant Waste Transfer Note arranged. Do not mix refrigerants in recovery units and especially not in cylinders.
 - If compressors or compressor oils are to be removed, ensure that they have been evacuated to an acceptable level to make certain that flammable refrigerant does not remain within the lubricant. The evacuation process shall be carried out prior to returning the compressor to the suppliers. Only electric heating to the compressor body shall be employed to accelerate this process. When oil is drained from a system, it shall be carried out safely.

Specifications

Contents

1.	Model Reference.....	2
2.	Pipe Length and Drop Height	3
3.	Electrical Wiring Diagrams	4

1. Model Reference

Refer to the following table to determine the specific indoor and outdoor unit model.

Indoor Unit Model	Outdoor Unit Model	Capacity (Btu/h)	Power Supply
B-VMH06SV-1	A-VMH06SV-1	6k	208/230~, 60Hz, 1Phase
B-VMH09SV-1	A-VMH09SV-1	9k	
	A-VMH09SV-1		
B-VMH12SV-1	A-VMH12SV-1	12k	
	A-VMH12SV-1		
B-VMH18SV-1	A-VMH18SV-1	18k	
	A-VMH18SV-1		
B-VMH24SV-1	A-VMH24SV-1	24k	
	A-VMH24SV-1		
B-VMH30SV-1	A-VMH30SV-1	30k	
B-VMH36SV-1	A-VMH36SV-1	36k	

2. Pipe Length and Drop Height

The length and elevation of connection pipe are shown in the table below. If the pipe length exceeds max pipe length, additional refrigerant should be charged to ensure nominal cooling/heating capacity.

Capacity(Btu/h)	Standard Length	Max Pipe Length	Max Elevation	Additional Refrigerant
6k~12k	7.5m (24.6ft)	25m (82.0ft)	10m (32.8ft)	15g/m (0.16oz/ft)
18k		30m (98.4ft)	20m (65.6ft)	
24k~30k	7.5m (24.6ft)	50m (164.04ft)	25m (82.02ft)	30g/m (0.32oz/ft)
36k		65m (213.2ft)	30m (82.02ft)	

If oil flows back into the outdoor unit's compressor, this might cause liquid compression or deterioration of oil return. Oil traps in the rising gas pipe can prevent this.

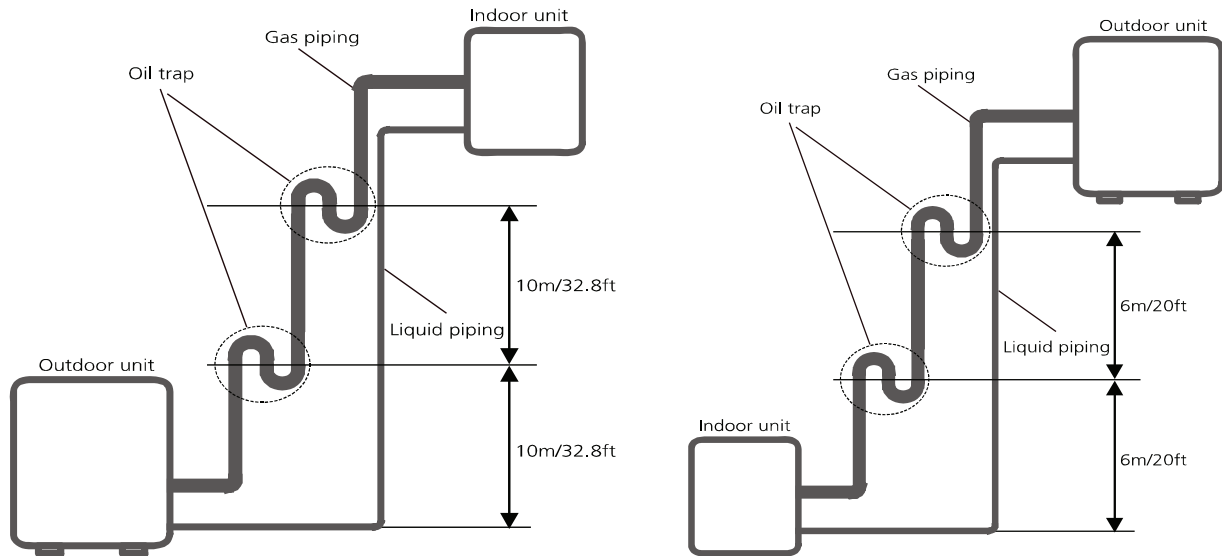

1. Indoor unit is installed higher than outdoor unit

2. Outdoor unit is installed higher than indoor unit

If indoor unit is installed higher than outdoor unit, oil trap should be set every 10m(32.8ft) of vertical distance.

If the outdoor unit is installed higher than the indoor unit, proper oil should return to the compressor along with the suction of refrigerant to keep lubrication of compressor. If the suction flow velocity drops below 7.62m/s(1500fpm (feet per minute)), oil won't return to the compressor. An oil trap should be installed every 6m(20ft) of vertical distance.

3. Electrical Wiring Diagrams

Indoor and outdoor unit wiring diagram

Indoor Unit		Outdoor Unit	
IDU Model	IDU Wiring Diagram	ODU Model	ODU Wiring Diagram
B-VMH06SV-1	16022000034669	A-VMH06SV-1	16022000035853
B-VMH09SV-1		A-VMH09SV-1	
B-VMH12SV-1		A-VMH12SV-1	
B-VMH18SV-1		A-VMH18SV-1	16022000035849
B-VMH24SV-1			
B-VMH30SV-1		A-VMH24SV-1	16022000034529
B-VMH36SV-1		A-VMH30SV-1	
		A-VMH36SV-1	

Outdoor unit printed circuit board diagram

Outdoor Unit	
ODU Model	ODU Printed Circuit Board
A-VMH06SV-1	17122000048121
A-VMH09SV-1	
A-VMH12SV-1	
A-VMH18SV-1	17122000041117
	17122000048064
A-VMH24SV-1	17122000047742
A-VMH30SV-1	
A-VMH36SV-1	

Indoor unit abbreviations

Abbreviation	Paraphrase
Y/G	Yellow-Green Conductor
ION	Positive and Negative Ion Generator
CAP	Capacitor
PLASMA	Electronic Dust Collector
L	LIVE
N	NEUTRAL

Outdoor unit abbreviations

Abbreviation	Paraphrase
4-WAY	Gas Valve Assembly/4-WAY VALVE
AC-FAN	Alternating Current FAN
DC-FAN	Direct Current FAN
COMP	Compressor
L-PRO	Low Pressure Switch
H-PRO	High Pressure Switch

INDOOR WIRING DIAGRAM

16022000034669

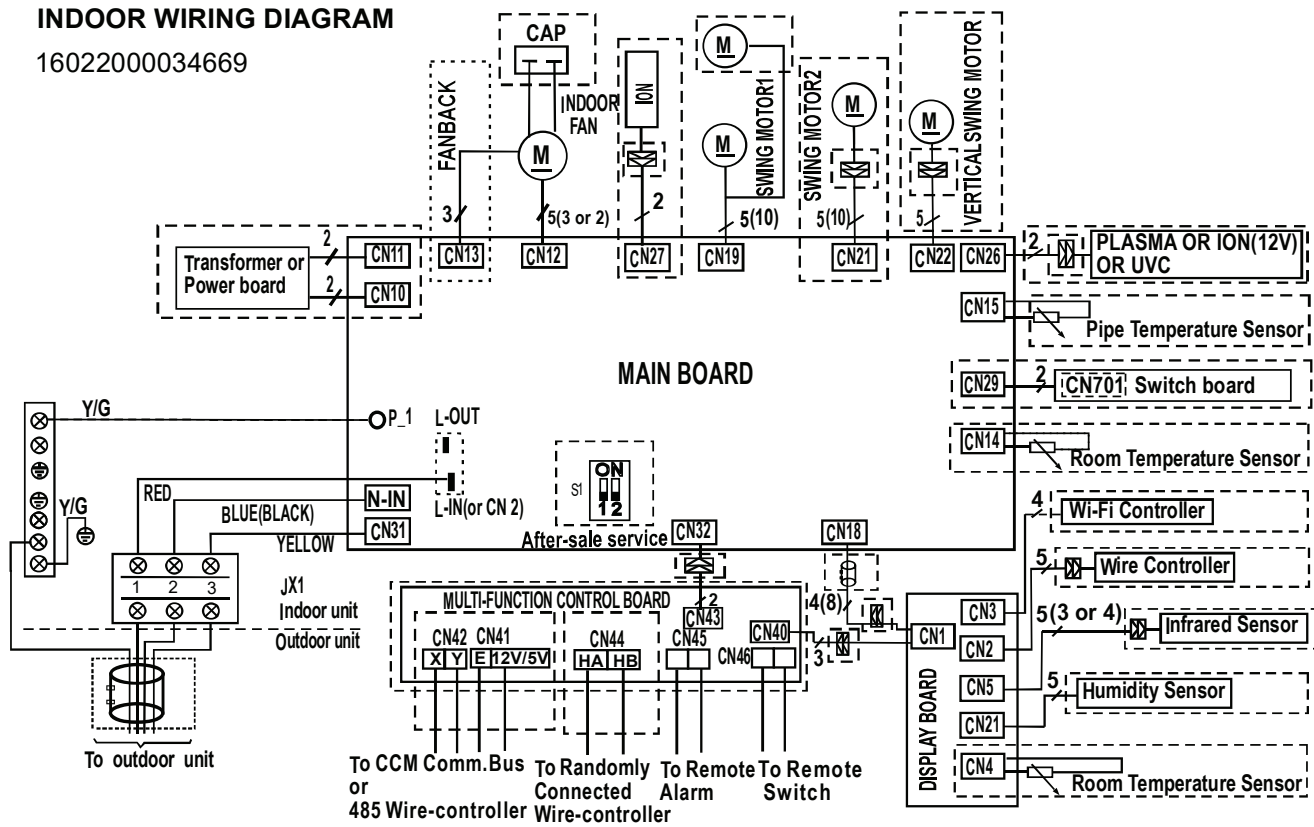

S1	1	S1	2	TYPE
OFF	OFF	9K		
ON	OFF	12K		
OFF	ON	18K		
ON	ON	24K		

After-sale service

FOR SETTING NETADDRESS (CCM Comm. Bus)			
ENC3+F1 (MULTI-FUNCTION CONTROL BOARD)			
CODE	0~F	0~F	0~F
NETADDRESS	0~15	16~31	32~47
FACTORY SETTING	✓		

OPTIONAL
 NOTE: The dotted bordered rectangle represents the component is optional, the actual shape shall prevail.

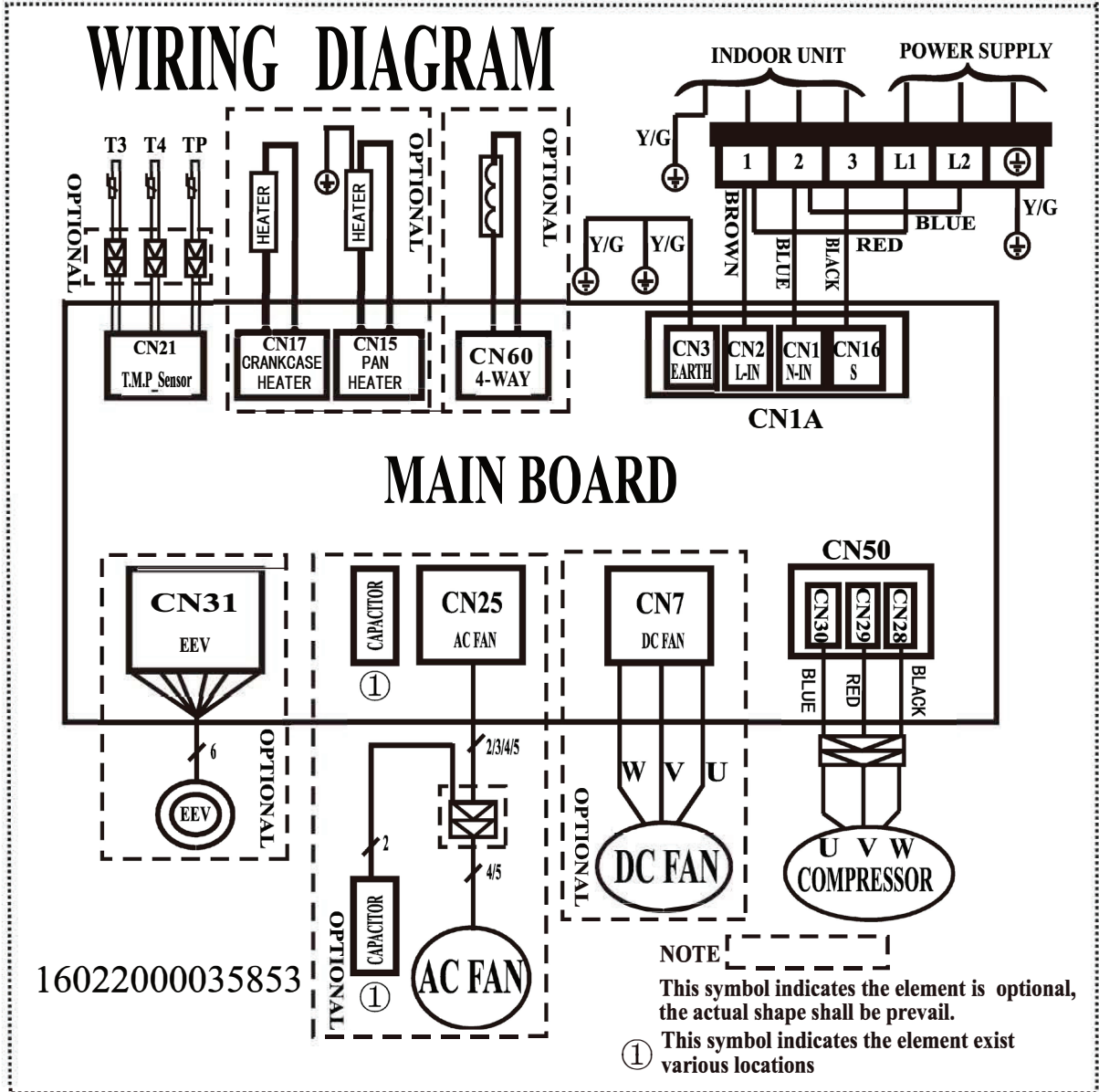

WIRING DIAGRAM

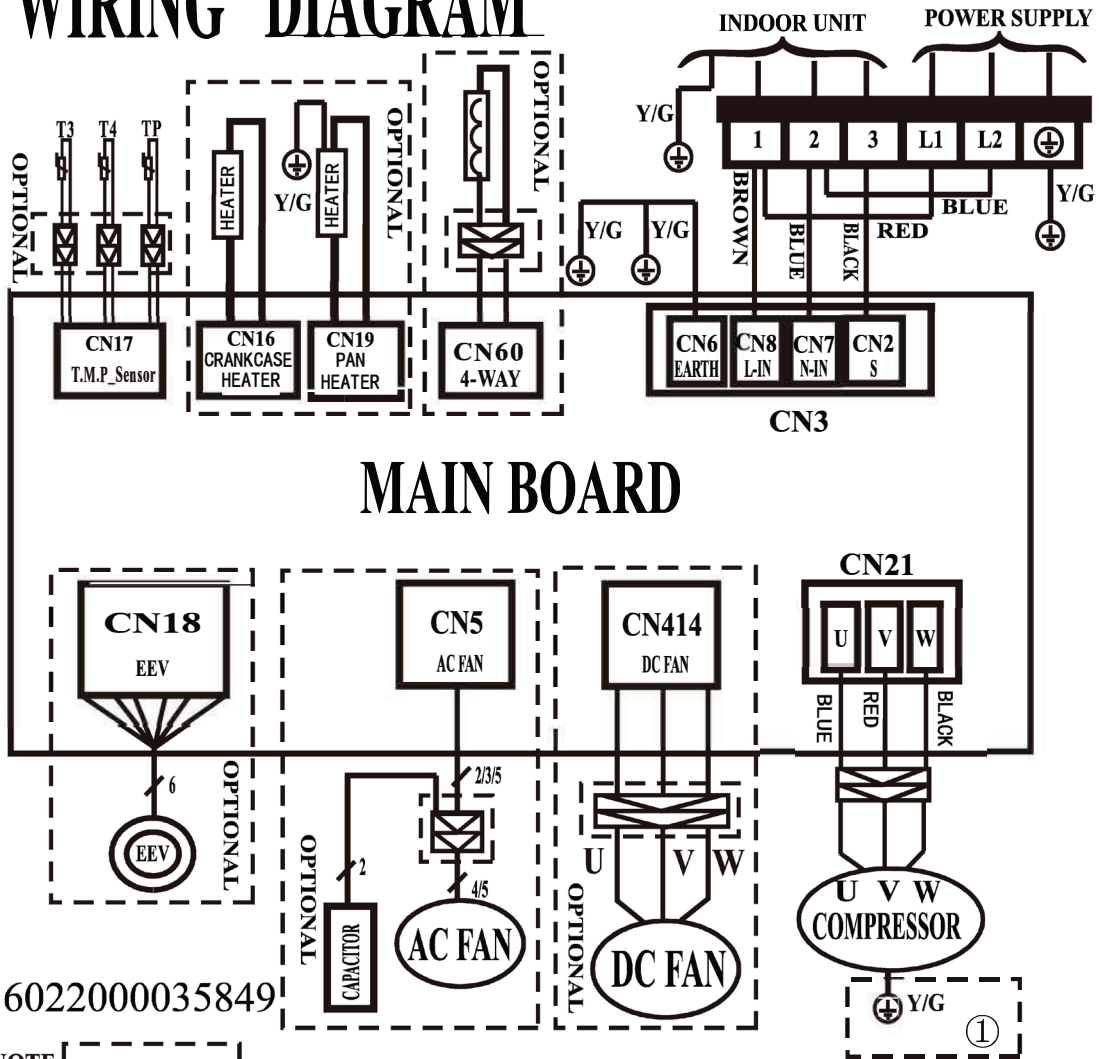

16022000035849

NOTE

This symbol indicates the element is optional, the actual shape shall be prevail.

①

The D box contains the ground wire of the compressor, and the other boxes do not.

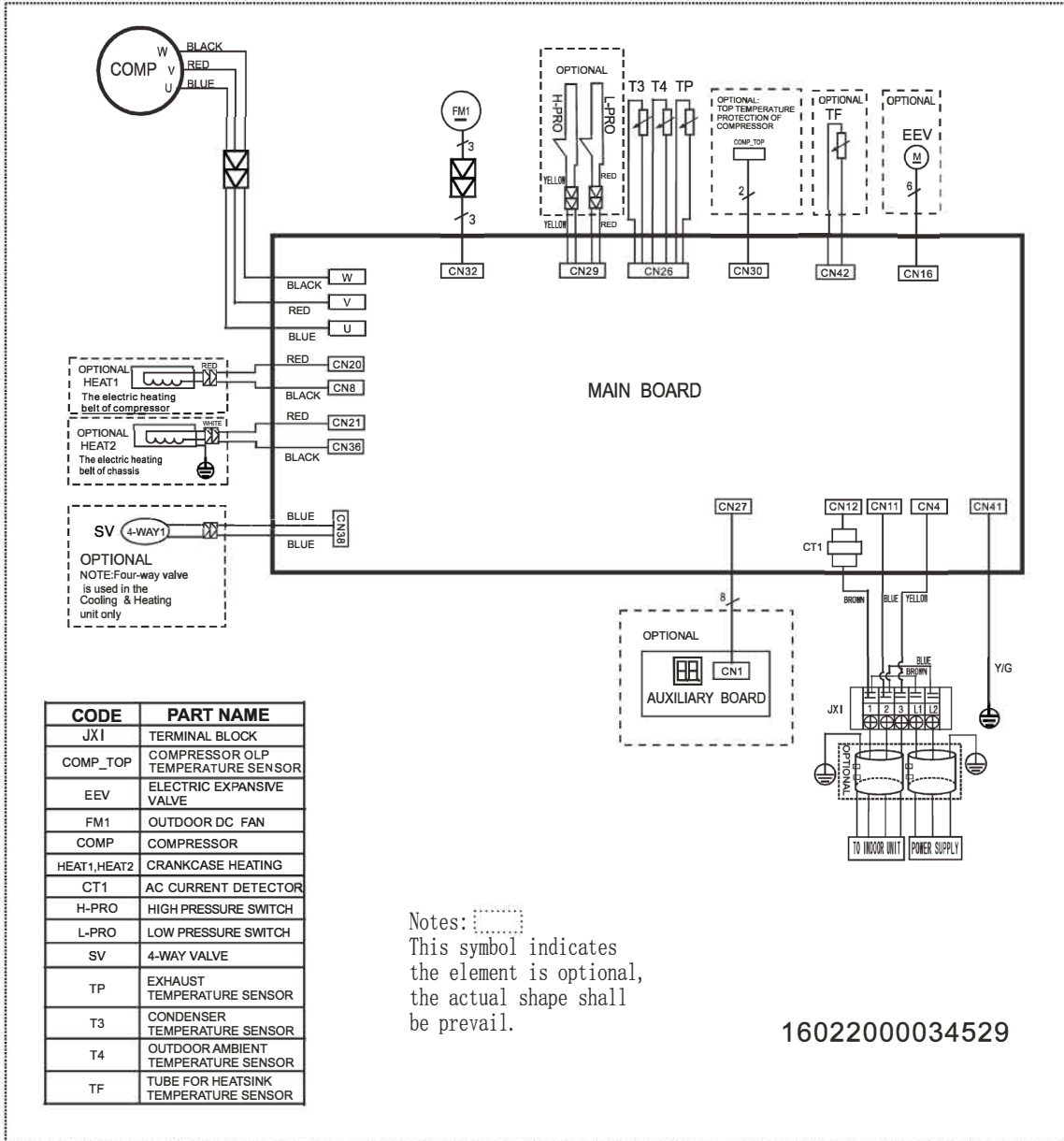

No.	Name	CN#	Meaning
1	CN1A	CN3	Earth: connect to Ground
		CN1	N_in: connect to N-line (208-230V AC input)
		CN2	L_in: connect to L-line (208-230V AC input)
		CN16	S: connect to indoor unit communication
2	HEAT1	CN17	connect to compressor heater, 208-230V AC when is ON
3	4-WAY	CN60	connect to 4 way valve, 208-230V AC when is ON.
4	HEAT2	CN15	connect to chassis heater, 208-230V AC when is ON
5	AC-FAN	CN25	connect to AC fan
6	PMV	CN31	connect to Electric Expansion Valve
7	TESTPORT	CN6	used for testing
8	TP T4 T3	CN21/CN22	connect to pipe temp. sensor T3, ambient temp. sensor T4, exhaust temp. sensor TP
9	DC-FAN	CN7	connect to DC fan
10	FAN_IPM	IPM 501	IPM for DC fan
11	W	CN28	connect to compressor
	V	CN29	0V AC (standby)
	U	CN30	10-200V AC (running)
12	COMP_IPM	IPM 301	IPM for compressor

Note: This section is for reference only. Please take practicality as standard.

No.	Name	CN#	Meaning
1	Power Supply	CN6	Earth: connect to Ground
		CN7	N_in: connect to N-line (208-230V AC input)
		CN8	L_in: connect to L-line (208-230V AC input)
2	S	CN2	S: connect to indoor unit communication
3	4-WAY	CN60	connect to 4 way valve, 208-230V AC when is ON.
4	HEAT1	CN16	connect to compressor heater, 208-230V AC when is ON
5	AC-FAN	CN5	connect to AC fan
6	HEAT2	CN19	connect to chassis heater, 208-230V AC when is ON
7	PMV	CN18	connect to Electric Expansion Valve
8	TP T4 T3	CN17	connect to pipe temp. sensor T3, ambient temp. sensor T4, exhaust temp. sensor TP
9	DC-FAN	CN41	connect to DC fan
10	TESTPORT	CN23	used for testing
11	FAN_IPM	IPM2	IPM for DC fan
12	EE_PORT	CN505	EEPROM programmer port
13	U	CN27	connect to compressor
	V	CN28	0V AC (standby)
	W	CN29	200-300V AC (running)
14	COMP_IPM	IPM1	IPM for compressor

Note: This section is for reference only. Please take practicality as standard.

No.	Name	CN#	Meaning
1	Power Supply	CN11	N_in: connect to N-line (208-230V AC input)
		CN12	L_in: connect to L-line (208-230V AC input)
2	EEV-A	CN16	connect to electric expansion valve
	EEV-B	CN13	
	EEV-C	CN3	
	EEV-D	CN15	
	EEV-E	CN1	
	EEV-F	CN17	
	EEV-G	CN14	
3	T3 T4 TP	CN26	connect to pipe temp. sensor T3, ambient temp. sensor T4, exhaust temp. sensor TP
4	H-PRO,L-RPO	CN29	connect to high and low pressure swtich(pin1-pin2&pin3-pin4:5VDC pulse wave)
5	OLP TEMP. SENSOR	CN30	connect to compressor top temp. sensor (5VDC Pulse wave)
6	TESTPORT	CN24	used for testing
7	COMPRESSOR	U	connect to compressor
		V	0V AC (standby)
		W	10-200V AC (running)
8	DC-FAN	CN32	connect to DC fan
9	S-E	CN31	S: connect to indoor unit communication(pin1-pin2: 24VDC Pulse wave; pin2-pin3: 208-230V AC input)
	S-D	CN5	
	S-C(mono)	CN34	
	S-B	CN2	
	S-A	CN4	

No.	Name	CN#	Meaning
10	HEAT_D	CN8	connect to the heater, 208-230V AC when is ON
		CN20	
11	HEAT_Y	CN21	
		CN36	
12	4-WAY	CN38	connect to 4 way valve, 208-230V AC when is ON.
13	/	CN27	connect to key board CN1

Note: This section is for reference only. Please take practicality as standard.

Product Features

Contents

1.	Display Functions	2
2	Safety Features	3
3.	Basic Functions	4
3.1	Abbreviations.....	4
3.2	Fan Mode.....	4
3.3	Cooling Mode	4
3.4	Heating Mode(Heat Pump Units)	5
3.5	Auto-mode.....	6
3.6	Drying Mode	7
3.7	Forced Operation Function	7
3.8	Timer Function	7
3.9	Sleep Function.....	7
3.10	Auto-Restart Function.....	8
3.11	Active Clean function	8
3.12	Follow me(Optional)	8
3.13	8°C (46°F) Heating(Optional)	8
3.14	Silence (Optional)	8
3.15	ECO function(Optional)	8
3.16	Electrical energy consumption control function(Optional).....	8
3.17	Breeze away function(Optional)	8
3.18	Wireless control(optional)	9

1. Display Function

Unit display functions









(A)



(B)



(C)

Display		Function
ECO		ECO function (available on select units only)
		when Wireless Control feature is activated(some units)
     	Temperature value	Temperature
		Timer ON is set.
		Activation of , Fresh, Swing, Turbo, ECO, Breeze away, ECO intelligent or Silence
		Timer OFF is set.
		Cancellation of Fresh, Swing, Turbo, ECO, Breeze away, ECO intelligent or Silent
		Defrost
	Active Clean (For Inverter split type) or self-cleaning(For Fixed-speed type)	
	Heating in room temperature under 8°C (46°F)	

Product Features

Note: Please select the display function according to your purchase product.

2. Safety Features

Compressor three-minute delay at restart

Compressor functions are delayed for up to ten seconds upon the first startup of the unit, and are delayed for up to three minutes upon subsequent unit restarts.

Automatic shutoff based on discharge temperature

If the compressor discharge temperature exceeds a certain level for a period of time, the compressor ceases operation.

Automatic shutoff based on fan speed

If the indoor fan speed registers below 200RPM or over 2100RPM for an extended period of time, the unit ceases operation and the corresponding error code is displayed on the indoor unit.

Inverter module protection

The inverter module has an automatic shutoff mechanism based on the unit's current, voltage, and temperature. If automatic shutoff is initiated, the corresponding error code is displayed on the indoor unit and the unit ceases operation.

Indoor fan delayed operation

- When the unit starts, the louver is automatically activated and the indoor fan will operate after a period of setting time or the louver is in place.
- If the unit is in heating mode, the indoor fan is regulated by the anti-cold wind function.

Compressor preheating

Preheating is automatically activated when T4 sensor is lower than setting temperature.

Sensor redundancy and automatic shutoff

- If one temperature sensor malfunctions, the air conditioner continues operation and displays the corresponding error code, allowing for emergency use.
- When more than one temperature sensor is malfunctioning, the air conditioner ceases operation.

3. Basic Functions

3.1 Abbreviation

Unit element abbreviations

Abbreviation	Element
T1	Indoor room temperature
T2	Coil temperature of evaporator
T3	Coil temperature of condenser
T4	Outdoor ambient temperature
Tsc	Adjusted setting temperature
TP	Compressor discharge temperature

3.2 Fan Mode

When fan mode is activated:

- The outdoor fan and compressor cease operation.
- Temperature control is disabled and indoor room temperature is displayed.
- The indoor fan speed can be set to 1%~100%, or auto.
- The louver operations are identical to those in cooling mode.
- Auto fan: In fan-only mode, AC operates the same as auto fan in cooling mode with the temperature set at 24°C.(Tsc =24°C)

3.3 Cooling Mode

3.3.1 Compressor Control

Reach the configured temperature:

- 1) When the compressor runs continuously for within 120 minutes.
 - If the following conditions are satisfied, the compressor ceases operation.
 - Calculated frequency(fb) is less than minimum limit frequency(FminC).
 - Compressor runs at FminC more than 10 minutes
 - T1 is lower than or equal to (Tsc-CDIFTEMP-0.5°C)

Note: CDIFTEMP is EEPROM setting parameter. It is 2°C usually.

- 2) When the compressor runs continuously for more than 120 minutes.
 - If the following conditions are satisfied, the compressor ceases operation.
 - Calculated frequency(fb) is less than minimum limit

frequency(FminC).

- Compressor runs at FminC more than 10 minutes.
- T1 is lower than or equal to (Tsc-CDIFTEMP).

Note: CDIFTEMP is EEPROM setting parameter. It is 2°C usually.

- 3) If one of the following conditions is satisfied, not judge protective time.

- Compressor running frequency(fr) is more than test frequency(TestFre).
- Compressor running frequency is equal to test frequency, T4 is more than 15°C or T4 fault.
- Change setting temperature.
- Turbo or sleep function on/off
- Various frequency limit shutdown occurs.

3.3.2 Indoor Fan Control

- 1) In cooling mode, the indoor fan operates continuously. The fan speed can be set to 1%-100%, or auto.
- 2) Auto fan

For DC fan motor units:

- Descent curve
 - When T1-Tsc is lower than or equal to 3.5°C, fan speed reduces to 80%;
 - When T1-Tsc is lower than or equal to 1°C, fan speed reduces to 60%;
 - When T1-Tsc is lower than or equal to 0.5°C, fan speed reduces to 40%;
 - When T1-Tsc is lower than or equal to 0°C, fan speed reduces to 20%;
 - When T1-Tsc is lower than or equal to -0.5°C, fan speed reduces to 1%.
- Rise curve
 - When T1-Tsc is higher than 0°C, fan speed increases to 20%;
 - When T1-Tsc is higher than 0.5°C, fan speed increases to 40%;
 - When T1-Tsc is higher than 1°C, fan speed increases to 60%;
 - When T1-Tsc is higher than 1.5°C, fan speed increases to 80%;
 - When T1-Tsc is higher than 4°C, fan speed increases to 100%.

For AC fan motor units:

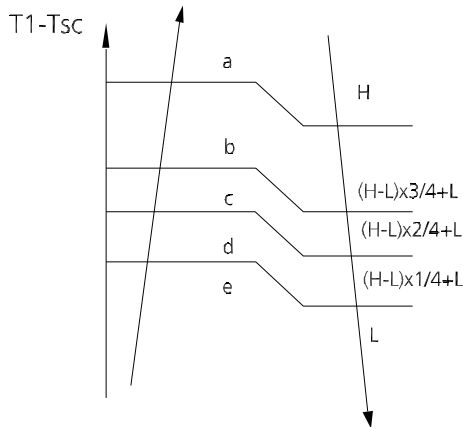

3.3.3 Outdoor Fan Control

- The outdoor unit will be run at different fan speed according to T4 and compressor running frequency..
- For different outdoor units, the fan speeds are different.

3.3.4 Condenser Temperature Protection

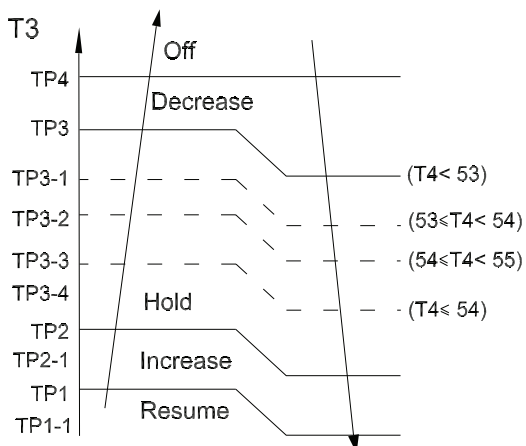

When the condenser temperature exceeds a configured value, the compressor ceases operation.

3.3.5 Evaporator Temperature Protection

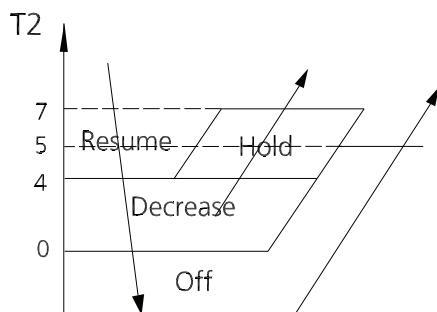

- Off: Compressor stops.
- Decrease: Decrease the running frequency to the lower

level per 1 minute.

- Hold: Keep the current frequency.
- Resume: No limitation for frequency.

3.4 Heating Mode(Heat Pump Units)

3.4.1 Compressor Control

1) Reach the configured temperature

- If the following conditions are satisfied, the compressor ceases operation.
 - Calculated frequency(fb) is less than minimum limit frequency(FminH).
 - Compressor runs at FminH more than 10 minutes.
 - T1 is higher than or equal to Tsc+ HDIFTEMP2.

Note: HDIFTEMP2 is EEPROM setting parameter. It is 2°C usually.

- If one of the following conditions is satisfied, not judge protective time.
 - Compressor running frequency(fr) is more than test frequency(TestFre).
 - When compressor running frequency is equal to test frequency, T4 is more than 15°C or T4 fault.
 - Change setting temperature.
 - Turbo or sleep function on/off.

2) When the current is higher than the predefined safe value, surge protection is activated, causing the compressor to cease operations.

3.4.2 Indoor Fan Control

1) In heating mode, the indoor fan operates continuously. The fan speed can be set to 1%-100%, or mute. And the anti-cold wind function has the priority.

- Anti-cold air function
 - The indoor fan is controlled by the indoor temperature T1 and indoor unit coil temperature T2.

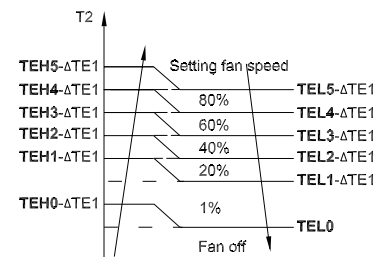

$T1 \geq 19^{\circ}\text{C} (66.2^{\circ}\text{F})$	$\Delta\text{TE1}=0$
$15^{\circ}\text{C} (59^{\circ}\text{F}) \leq T1 < 19^{\circ}\text{C} (66.2^{\circ}\text{F})$	$\Delta\text{TE1}=19^{\circ}\text{C}-T1$ ($34.2^{\circ}\text{F}-T1$)
$T1 < 15^{\circ}\text{C} (59^{\circ}\text{F})$	$\Delta\text{TE1}=4^{\circ}\text{C} (7.2^{\circ}\text{F})$

2) Auto fan

For DC fan motor units:

- Rise curve
 - When T1-Tsc is higher than -1.5°C , fan speed reduces to 80%;
 - When T1-Tsc is higher than 0°C , fan speed reduces to 60%;
 - When T1-Tsc is higher than 0.5°C , fan speed reduces to 40%;
 - When T1-Tsc is higher than 1°C , fan speed reduces to 20%.
- Descent curve
 - When T1-Tsc is lower than or equal to 0.5°C , fan speed increases to 40%;
 - When T1-Tsc is lower than or equal to 0°C , fan speed increases to 60%;
 - When T1-Tsc is lower than or equal to -1.5°C , fan speed increases to 80%;
 - When T1-Tsc is lower than or equal to -3°C , fan speed increases to 100%.

For AC fan motor units:

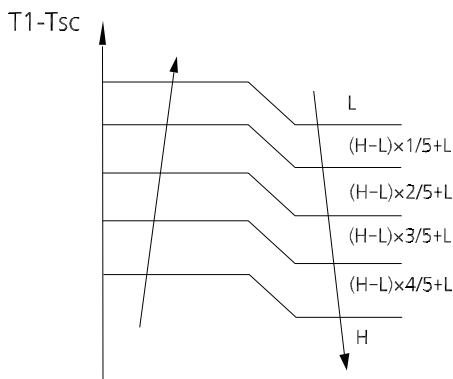

3.4.3 Outdoor Fan Control:

- The outdoor unit will be run at different fan speed according to T4 and compressor running frequency.
- For different outdoor units, the fan speeds are different.

3.4.4 Defrosting mode

- The unit enters defrosting mode according to changes in the temperature value of T3, T4 as well as the compressor running time.
- In defrosting mode, the compressor continues to run, the indoor and outdoor motor will cease operation, the defrost light of the indoor unit will turn on, and the "df" symbol is displayed.
- If any one of the following conditions is satisfied,

defrosting ends and the machine switches to normal heating mode:

- T3 rises above $\text{TCDE}1^{\circ}\text{C}$.
- T3 maintained above $\text{TCDE}2^{\circ}\text{C}$ for 80 seconds.
- Unit runs for 15 minutes consecutively in defrosting mode.
- If T4 is lower than or equal to -22°C and compressor running time is more than $\text{TIMING_DEFROST_TIME}$, if any one of the following conditions is satisfied, defrosting ends and the machine switches to normal heating mode:
 - Unit runs for 10 minutes consecutively in defrosting mode.
 - T3 rises above 10°C .

For some models:

- If T3 is lower than 3°C and compressor running time is more than 120 minutes, at this time, if T3 is lower than $\text{TCDI}1+4^{\circ}\text{C}$ (39.2°F) for 3 minutes, the unit enters defrosting mode.

For some models:

- If any one of the following conditions is satisfied, the unit enters defrosting mode
 - If T3 or T4 is lower than -3°C for 30 seconds, $\text{Ts}-\text{T1}$ is lower than 5°C and compressor running time is more than $\text{EE_TIME_DEFROST}7$.
 - If T3 or T4 is lower than -3°C for 30 seconds and compressor running time is more than $\text{EE_TIME_DEFROST}7+30$.
- If any one of the following conditions is satisfied, defrosting ends and the machine switches to normal heating mode:
 - T3 rises above $\text{TCDE}1+4^{\circ}\text{C}$.
 - T3 maintained above $\text{TCDE}2+4^{\circ}\text{C}$ for 80 seconds.
 - Unit runs for 15 minutes consecutively in defrosting mode.

3.4.5 Evaporator Temperature Protection

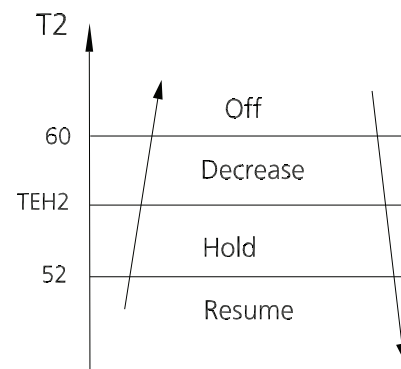

- Off: Compressor stops.

- Decrease: Decrease the running frequency to the lower level per 20 seconds.
- Hold: Keep the current frequency.
- Resume: No limitation for frequency.

3.5 Auto-mode

- This mode can be selected with the remote controller and the setting temperature can be changed between 16°C~30°C.
- In auto mode, the machine selects cooling, heating, auto-drying or fan-only mode on the basis of T1, Ts, T4 and relative humidity.

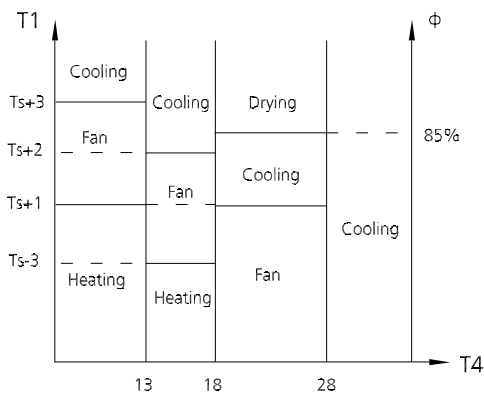

- If the setting temperature is modified, the machine selects a new running function.

3.6 Drying mode

- In drying mode, AC operates the same as auto fan in cooling mode.
- All protections are activated and operate the same as they do in cooling mode.
- Low Room Temperature Protection

If the room temperature is lower than 10°C, the compressor ceases operations and does not resume until room temperature exceeds 12°C.

3.7 Forced operation function

- Forced cooling mode:

The compressor and outdoor fan continue to run (fixed at rated frequency), and the indoor fan runs at rated speed. After running for 30 minutes, the AC will switch to auto mode with a preset temperature of 24°C.

- Forced auto mode:

Forced auto mode operates the same as normal auto mode with a preset temperature of 24°C.

- The unit exits forced operation when it receives the

following signals:

- Switch on
- Switch off
- Timer on
- Timer off
- Sleep mode
- Follow me
- Changes in:
 - mode
 - fan speed
 - setting temperature
- Forced defrosting mode:
 - Press AUTO/COOL button continuously for 5s under forced cooling mode to enter this mode.
 - Indoor fan will stop, defrosting lamp will light on.
 - Quit this mode and turn off the unit when:
 - quit normal defrosting
 - turn off by RC
 - Press AUTO/COOL button continuously for 5s again

3.8 Timer function

- Timing range is 24 hours.
- Timer on. The machine will turn on automatically when reaching the setting time.
- Timer off. The machine will turn off automatically when reaching the setting time.
- Timer on/off. The machine will turn on automatically when reaching the setting "on" time, and then turn off automatically when reaching the setting "off" time.
- Timer off/on. The machine will turn off automatically when reaching the setting "off" time, and then turn on automatically when reaching the setting "on" time.
- The timer function will not change the AC current operation mode. Suppose AC is off now, it will not start up firstly after setting the "timer off" function. And when reaching the setting time, the timer LED will be off and the AC running mode has not been changed.
- The setting time is relative time.
- The AC will quit the timer function when it has malfunction

3.9 Sleep function

- The sleep function is available in cooling, heating, or auto mode.

- The operational process for sleep mode is as follows:
 - When cooling, the temperature rises 1°C (to not higher than 30°C) every hour. After 2 hours, the temperature stops rising and the indoor fan is fixed at low speed.
 - When heating, the temperature decreases 1°C (to not lower than 16°C) every hour. After 2 hours, the temperature stops decreasing and the indoor fan is fixed at low speed. Anti-cold wind function takes priority.
- The operating time for sleep mode is 8 hours, after which, the unit exits this mode.
- The timer setting is available in this mode.

3.10 Auto-Restart function

- The indoor unit has an auto-restart module that allows the unit to restart automatically. The module automatically stores the current settings and, in the case of a sudden power failure, will restore those setting automatically within 3 minutes after power returns.
- If there is a power failure while the unit is running, the compressor starts 3 minutes after the unit restarts. If the unit was already off before the power failure, the unit stands by.

3.11 Active Clean function

- The Active Clean Technology washes away dust, mold, and grease that may cause odors when it adheres to the heat exchanger by automatically freezing and then rapidly thawing the frost. The internal wind wheel then keeps operating to blow-dry the evaporator, thus preventing the growth of mold and keeping the inside clean.
- When this function is turned on, the indoor unit display window appears "CL", after 20 to 45 minutes, the unit will turn off automatically and cancel Active Clean function.

3.12 Follow me(Optional)

- If you press "Follow Me" on the remote, the indoor unit will beep. This indicates the follow me function is active.
- Once active, the remote control will send a signal every 3 minutes, with no beeps. The unit automatically sets the temperature according to the measurements from the remote control.
- The unit will only change modes if the information from the remote control makes it necessary, not from the unit's temperature setting.
- If the unit does not receive a signal for 7 minutes or

you press "Follow Me," the function turns off. The unit regulates temperature based on its own sensor and settings.

3.13 8°C Heating(Optional) (46°F)

In heating mode, the temperature can be set to as low as 8°C, preventing the indoor area from freezing if unoccupied during severe cold weather.

3.14 Silence (Optional)

Press "Silence" on the remote control to enable the SILENCE function. While this function is active, the indoor unit will run at faint breeze(1% fan speed), which reduces noise to the lowest possible level.

3.15 ECO function (Optional)

- Used to enter the energy efficient mode.
 - Under cooling mode, press ECO button, the remote controller will adjust the temperature automatically to 24°C, fan speed of Auto to save energy (but only if the set temperature is less than 24°C). If the set temperature is more than 24°C and 30°C, press the ECO button, the fan speed will change to Auto, the set temperature will remain unchanged.
- When AC receives signals, such as switch off, Turbo operation, Silence operation, Self clean operation, Forced cooling operation, mode setting, Sleeping mode, or adjusting the set temperature to less than 24°C, it will quit the ECO operation.
- Operation time in ECO mode is 8 hours. After 8 hours the AC quits this mode.
- When there's any one temperature sensor in malfunction, the AC will quit ECO mode.
- Indoor fan will run at auto fan when enter into the ECO mode. The setting temperature and setting fan speed can be changed through remote controller signal.

3.16 Electrical energy consumption control function (Optional)

Press the "Gear" button on remote controller to enter the energy efficient mode in a sequence of following:

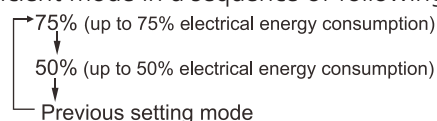

Turn off the unit or activate ECO, sleep, Super cool, 8°C Heating, Silence or self clean function will quit this function.

3.17 Breeze Away function (Optional)

- This feature avoids direct airflow blowing on the body.
- NOTE: This feature is available under cooling mode, fan-only mode and drying mode.

3.18 Wireless Control (Optional)

- Wireless control allows you to control your air conditioner using your mobile phone and a Wireless connection.
- For the USB device access, replacement, maintenance operations must be carried out by professional staff.

Maintenance

Contents

1.	First Time Installation Check	2
2	Refrigerant Recharge	4
3	Re-Installation	5
3.1	Indoor Unit.....	5
3.2	Outdoor Unit.....	7

1. First Time Installation Check

Air and moisture trapped in the refrigerant system affects the performance of the air conditioner by:

- Increasing pressure in the system.
- Increasing the operating current.
- Decreasing the cooling or heating efficiency.
- Congesting the capillary tubing due to ice build-up in the refrigerant circuit.
- Corroding the refrigerant system.

To prevent air and moisture from affecting the air conditioner's performance, the indoor unit, as well as the pipes between the indoor and outdoor unit, must be leak tested and evacuated.

Leak test (soap water method)

Use a soft brush to apply soapy water or a neutral liquid detergent onto the indoor unit connections and outdoor unit connections. If there is gas leakage, bubbles will form on the connection.

Air purging with vacuum pump

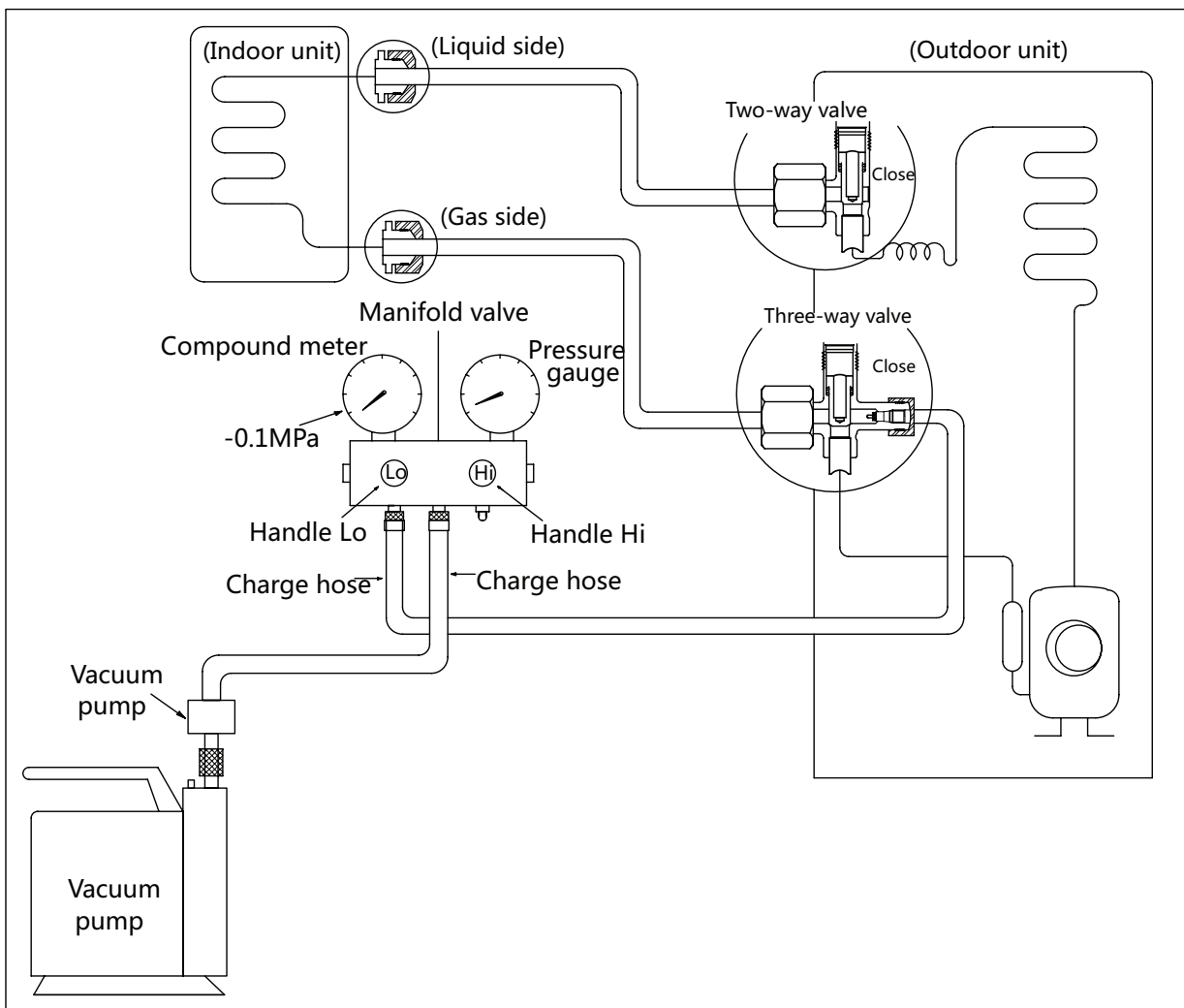

Procedure:

1. Tighten the flare nuts of the indoor and outdoor units, and confirm that both the 2- and 3-way valves are closed.
2. Connect the charge hose with the push pin of Handle Lo to the gas service port of the 3-way valve.
3. Connect another charge hose to the vacuum pump.
4. Fully open the Handle Lo manifold valve.
5. Using the vacuum pump, evacuate the system for 30 minutes.
 - a. Check whether the compound meter indicates -0.1 MPa (14.5 Psi).
 - If the meter does not indicate -0.1 MPa (14.5 Psi) after 30 minutes, continue evacuating for an additional 20 minutes.
 - If the pressure does not achieve -0.1 MPa (14.5 Psi) after 50 minutes, check for leakage.
6. Loosen the flare nut of the 3-way valve for 6 or 7 seconds and then tighten the flare nut again.
 - a. Confirm the pressure display in the pressure indicator is slightly higher than the atmospheric pressure.
 - b. Remove the charge hose from the 3-way valve.
7. Fully open the 2- and 3-way valves and tighten the cap of the 2- and 3-way valves.
 - If the pressure successfully reaches -0.1 MPa (14.5 Psi), fully close the Handle Lo valve, then cease vacuum pump operations.
8. Wait for 5 minutes then check whether the gauge needle moves after turning off the vacuum pump. If the gauge needle moves backward, check whether there is gas leakage.

2. Refrigerant Recharge

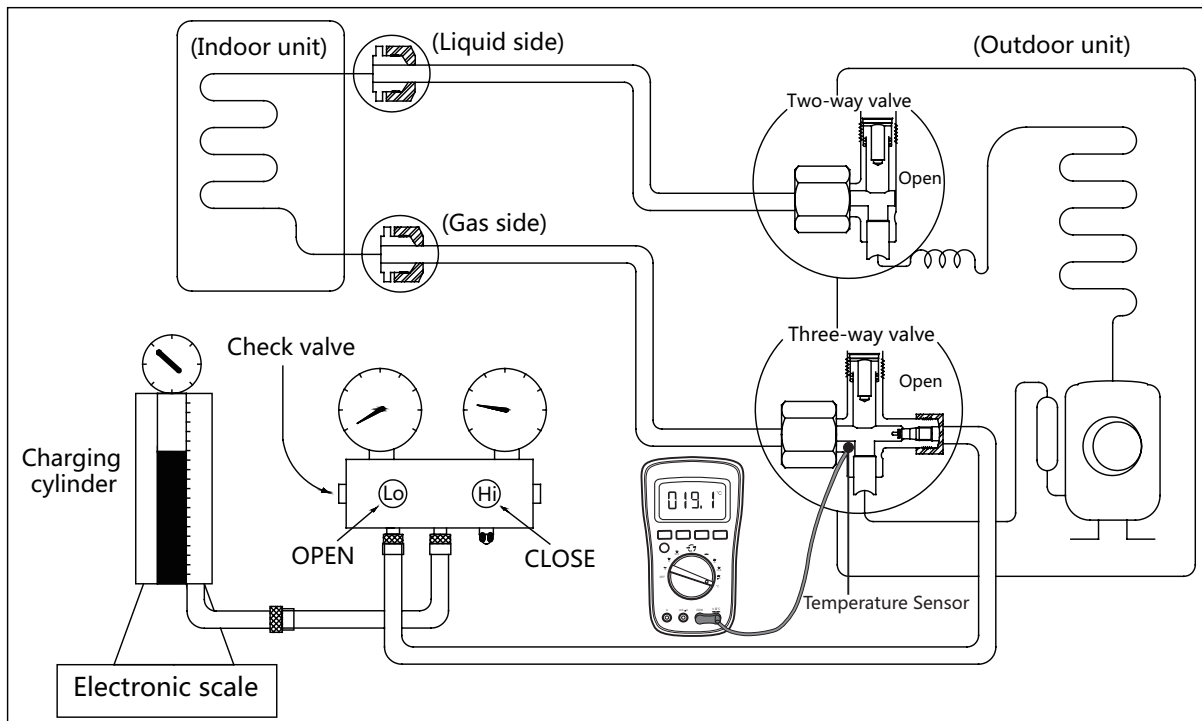

Procedure:

1. Close both 2- and 3-way valves.
2. Slightly connect the Handle Lo charge hose to the 3-way service port.
3. Connect the charge hose to the valve at the bottom of the cylinder.
4. If the refrigerant is R410A/R32, invert the cylinder to ensure a complete liquid charge.
5. Open the valve at the bottom of the cylinder for 5 seconds to purge the air in the charge hose, then fully tighten the charge hose with push pin Handle Lo to the service port of 3-way valve..
6. Place the charging cylinder onto an electronic scale and record the starting weight.
7. Fully open the Handle Lo manifold valve, 2- and 3-way valves.
8. Operate the air conditioner in cooling mode to charge the system with liquid refrigerant.
9. When the electronic scale displays the correct weight (refer to the gauge and the pressure of the low side to confirm, the value of pressure refers to chapter Appendix), turn off the air conditioner, then disconnect the charge hose from the 3-way service port immediately..
10. Mount the caps of service port and 2- and 3-way valves.
11. Use a torque wrench to tighten the caps to a torque of 18 N.m.
12. Check for gas leakage.

3. Re-Installation

3.1 Indoor Unit

Collecting the refrigerant into the outdoor unit

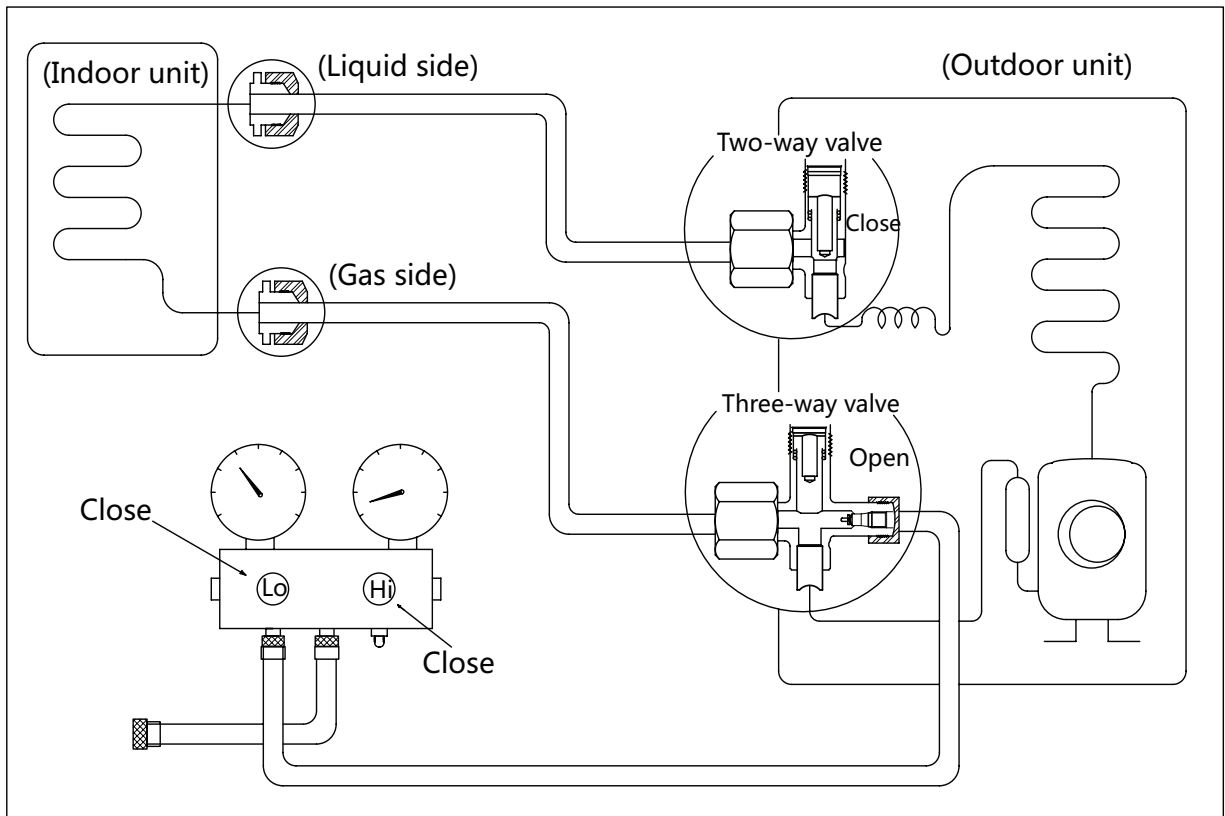

Procedure:

1. Confirm that the 2- and 3-way valves are opened.
2. Connect the charge hose with the push pin of Handle Lo to the 3-way valve's gas service port.
3. Open the Handle Lo manifold valve to purge air from the charge hose for 5 seconds and then close it quickly.
4. Close the 2-way valve.
5. Operate the air conditioner in cooling mode. Cease operations when the gauge reaches 0.1 MPa (14.5 Psi).
6. Close the 3-way valve so that the gauge rests between 0.3 MPa (43.5 Psi) and 0.5 MPa (72.5 Psi).
7. Disconnect the charge set and mount the caps of service port and 2- and 3-way valves.
8. Use a torque wrench to tighten the caps to a torque of 18 N.m.
9. Check for gas leakage.

Air purging with vacuum pump

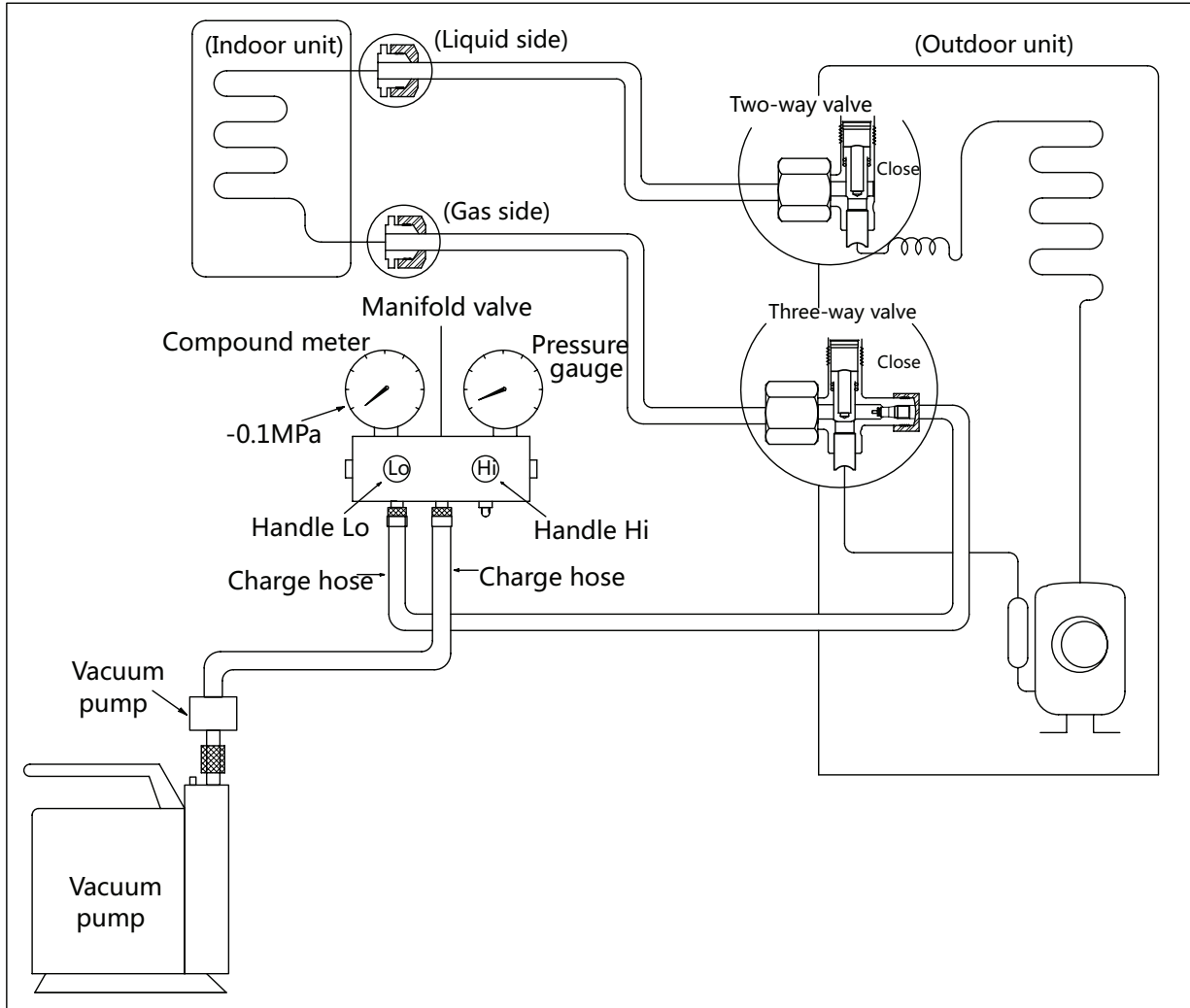

Procedure:

1. Tighten the flare nuts of the indoor and outdoor units, and confirm that both the 2- and 3-way valves are closed.
2. Connect the charge hose with the push pin of Handle Lo to the gas service port of the 3-way valve.
3. Connect another charge hose to the vacuum pump.
4. Fully open the Handle Lo manifold valve.
5. Using the vacuum pump, evacuate the system for 30 minutes.
 - a. Check whether the compound meter indicates -0.1 MPa (14.5 Psi).
 - If the meter does not indicate -0.1 MPa (14.5 Psi) after 30 minutes, continue evacuating for an additional 20 minutes.
 - If the pressure does not achieve -0.1 MPa (14.5 Psi) after 50 minutes, check for leakage.
 - b. If the pressure successfully reaches -0.1 MPa (14.5 Psi), fully close the Handle Lo valve, then cease vacuum pump operations.
6. Wait for 5 minutes then check whether the gauge needle moves after turning off the vacuum pump. If the gauge needle moves backward, check whether there is gas leakage.
 - a. Loosen the flare nut of the 3-way valve for 6 or 7 seconds and then tighten the flare nut again.
 - b. Confirm the pressure display in the pressure indicator is slightly higher than the atmospheric pressure.
 - c. Remove the charge hose from the 3-way valve.
7. Fully open the 2- and 3-way valves and tighten the cap of the 2- and 3-way valves.

Refrigerant charging

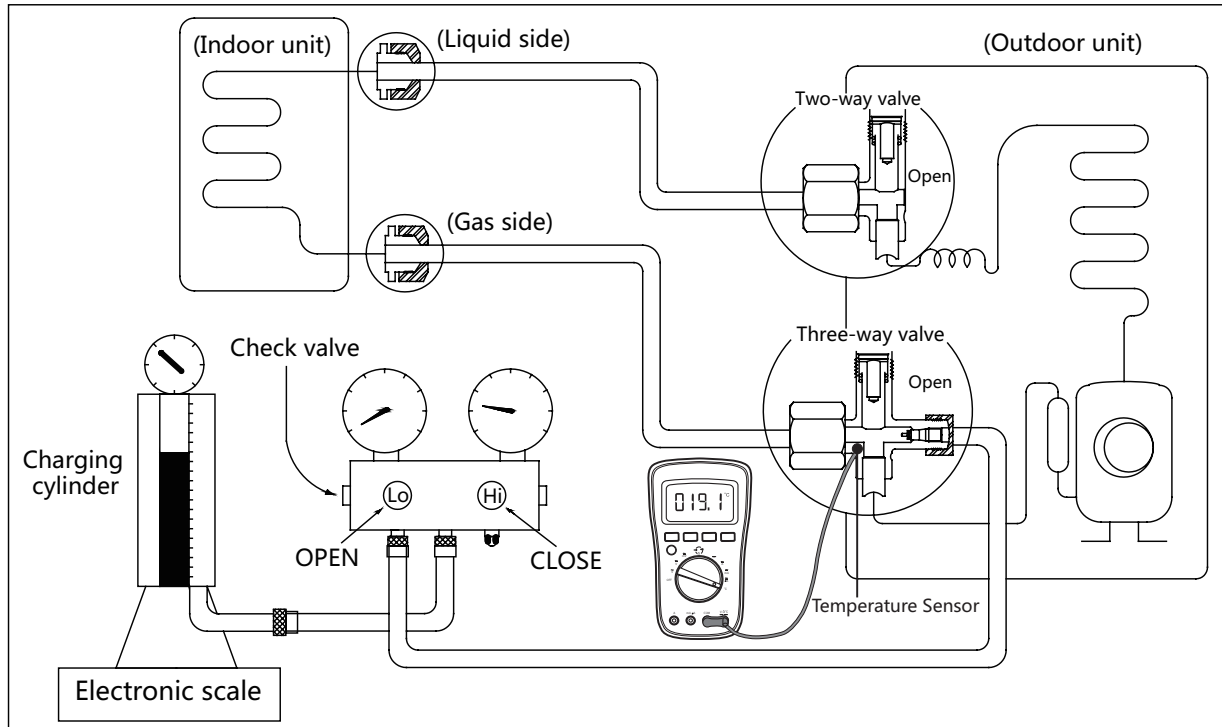

Procedure:

1. Close both 2- and 3-way valves.
2. Slightly connect the Handle Lo charge hose to the 3-way service port.
3. Connect the charge hose to the valve at the bottom of the cylinder.
4. If the refrigerant is R410A/R32, invert the cylinder to ensure a complete liquid charge.
5. Open the valve at the bottom of the cylinder for 5 seconds to purge the air in the charge hose, then fully tighten the charge hose with push pin Handle Lo to the service port of 3-way valve..
6. Place the charging cylinder onto an electronic scale and record the starting weight.
7. Fully open the Handle Lo manifold valve, 2- and 3-way valves.
8. Operate the air conditioner in cooling mode to charge the system with liquid refrigerant.
9. When the electronic scale displays the correct weight (refer to the gauge and the pressure of the low side to confirm, the value of pressure refers to chapter Appendix), turn off the air conditioner, then disconnect the charge hose from the 3-way service port immediately..
10. Mount the caps of service port and 2- and 3-way valves.
11. Use a torque wrench to tighten the caps to a torque of 18 N.m.
12. Check for gas leakage.

Note: 1. Mechanical connectors used indoors shall comply with local regulations.

2. When mechanical connectors are reused indoors, sealing parts shall be renewed. When flared joints are reused indoors, the flare part shall be re-fabricated.

Indoor Unit Disassembly

Contents

1.	Dimension	2
2.	Indoor Unit Disassembly	3
2.1	Front Panel	3
2.2	Electrical parts	7
2.3	Fan motor and fan.....	10
2.4	Step motor	12
2.5	Drain Hose	14
2.6	Evaporator.....	15

1. Dimension

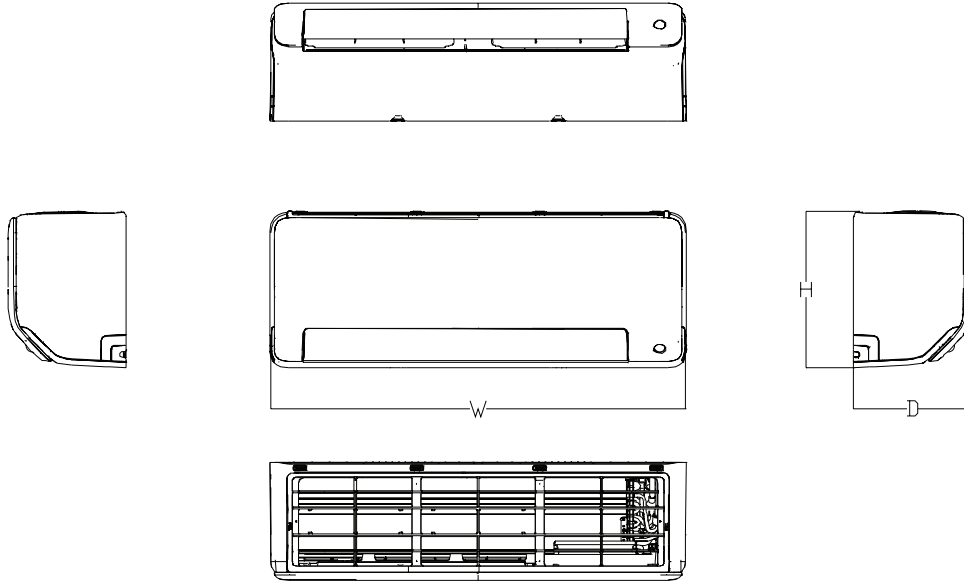

Capacity	Body Code	W(mm/inch)	D(mm/inch)	H(mm/inch)
9k~12k	B	795/31.3	225/8.86	295/11.61
18k~24k	C	965/38	239/9.41	319/12.56
24k~36k	D	1140/44.88	275/10.83	370/14.57

2. Indoor unit Disassembly

2.1 Front Panel

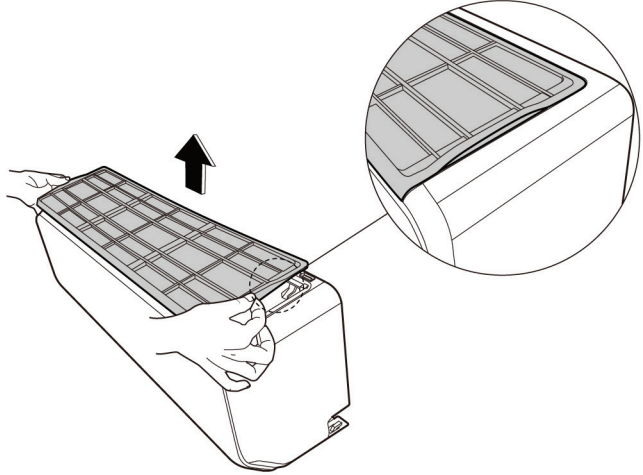
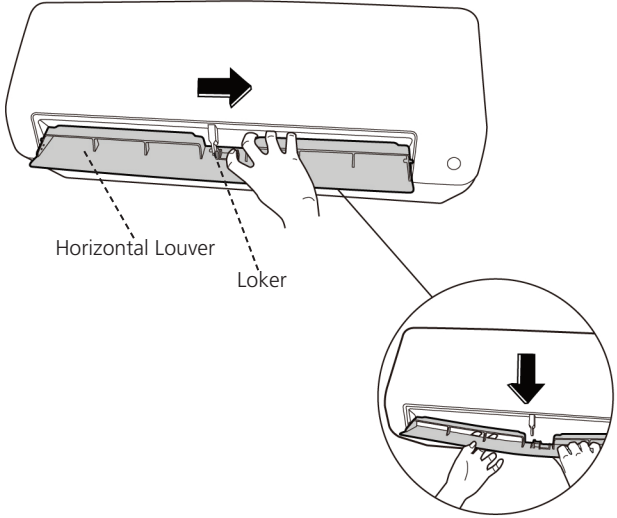
Procedure	Illustration
<p>1) Put your hands at the 2 sides of filter, pull the filter gently along the vertical direction, and then remove it.(see CJ_EP_001)</p>	 <p style="text-align: center;">CJ_EP_001</p>
<p>2) Open the horizontal louver and push the locker towards right to open it. (see CJ_EP_002)</p> <p>3) Bend the horizontal louver lightly to loosen the hooks, then remove the horizontal louver. (see CJ_EP_002)</p>	 <p style="text-align: center;">CJ_EP_002</p>

Note: This section is for reference only. Actual unit appearance may vary.

Procedure**Illustration**

- 4) Open the panel assembly, move the slider to fix the panel. (see CJ_EP_003)

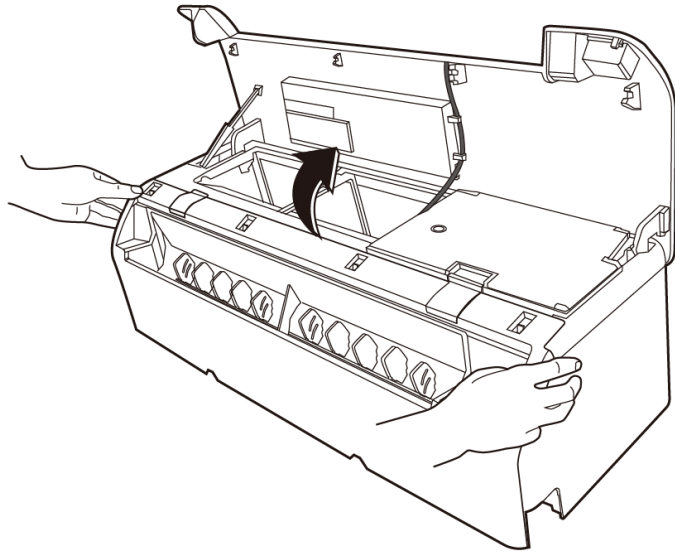
**CJ_EP_003**

- 5) Open two stop blocks of panel frame assembly. (see CJ_EP_004)
- 6) Remove 1 fixing screw in the panel frame. (see CJ_EP_004)

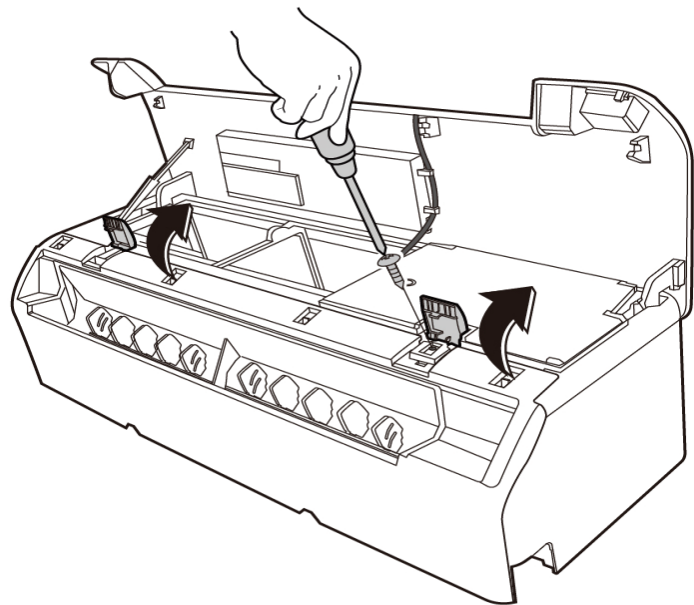
**CJ_EP_004**

Note: This section is for reference only. Actual unit appearance may vary.

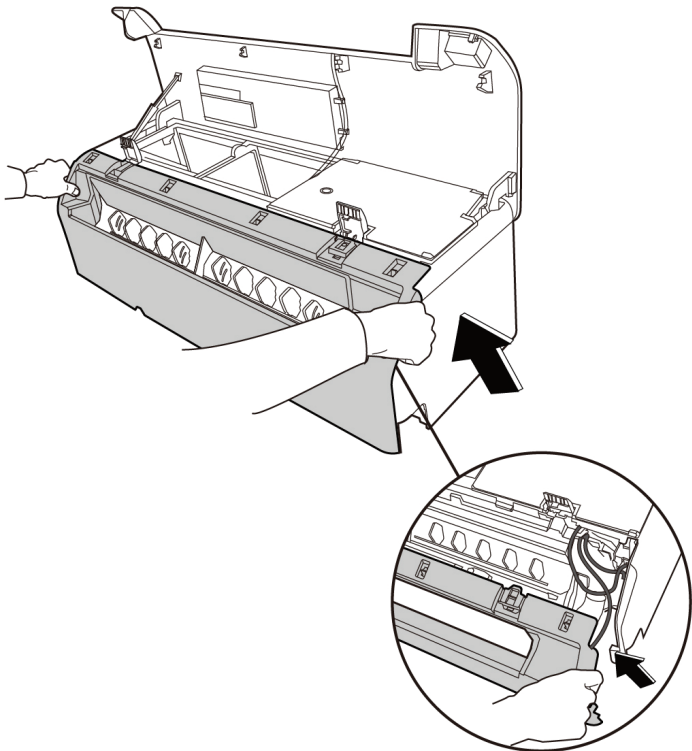
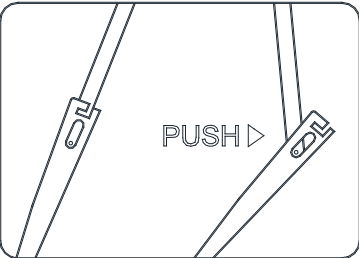
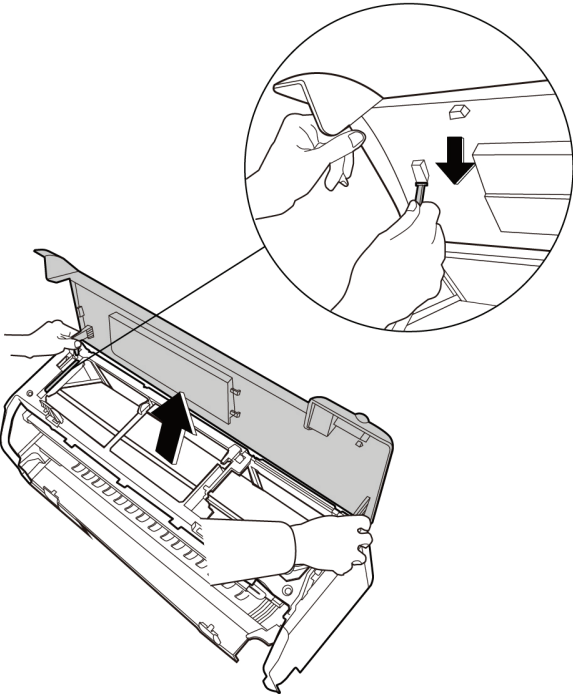
Procedure	Illustration
<p>7) pull two sides of the bottom panel along the direction indicated in right image to remove it. (see CJ_EP_005)</p>	 <p style="text-align: center;">CJ_EP_005</p>
<p>8) Pull the mandril of panel to remove it.(see CJ_EP_006)</p> <p>9) Remove the panel assembly.(see CJ_EP_006)</p> <p>(Caution: If you want to close the panel, you must bend the middle of mandril, otherwise it will break. For 7k~18k models, mandril is located on the left of the machine. For 24k up models, it is located in the middle of the machine)(see CJ_EP_006-1)</p>  <p style="text-align: center;">CJ_EP_006-1</p>	 <p style="text-align: center;">CJ_EP_006</p>

Note: This section is for reference only. Actual unit appearance may vary.

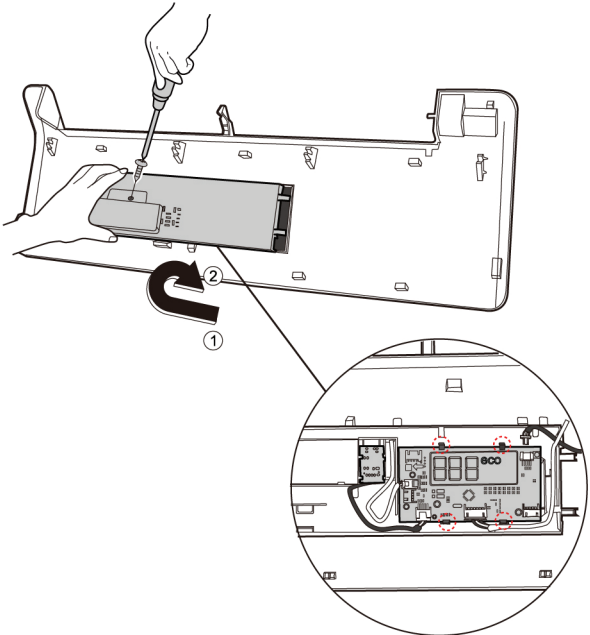
Procedure	Illustration
<p>10) Remove 1 screw of the display board. (see CJ_EP_007)</p> <p>11) Rotate the display board subassembly in the direction shown in the right picture. (see CJ_EP_007)</p> <p>12) Pull the four clips to remove the display board.(see CJ_EP_007)</p>	 <p style="text-align: center;">CJ_EP_007</p>

Note: This section is for reference only. Actual unit appearance may vary.

2.2 Electrical parts (Antistatic gloves must be worn.)

Note: Open the front panel (refer to 2.1 Front panel) before disassembling electrical parts.

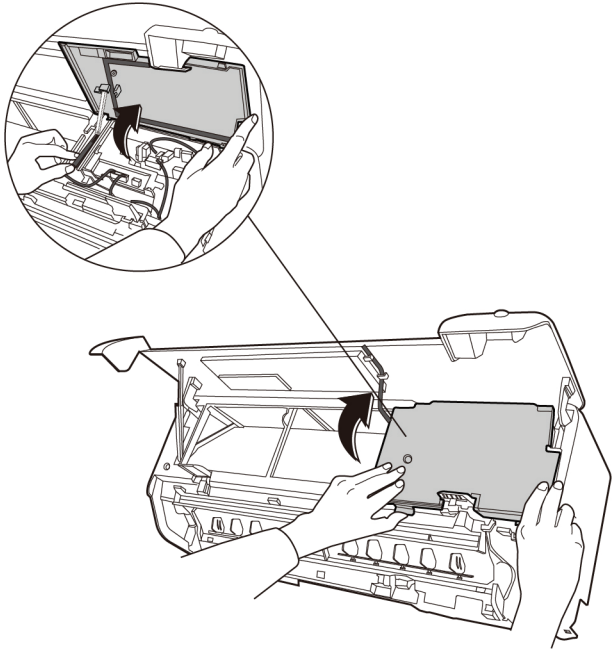
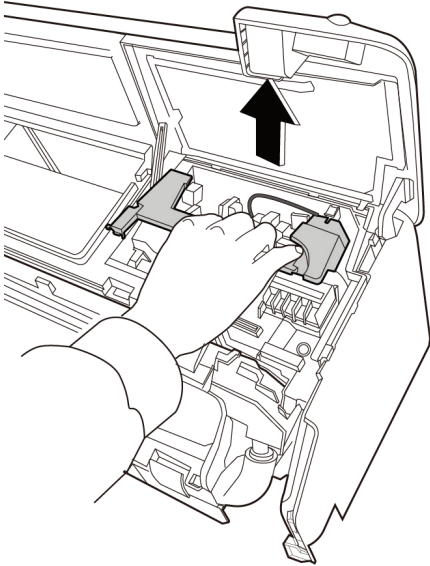
Procedure	Illustration
<p>1) Pull the two lifts of the cover of electronic control box with thumbs and then open it. (see CJ_EP_008)</p> <p>2) Raise the mandril to fix the cover.(see CJ_EP_008)</p>	 <p>CJ_EP_008</p>
<p>3) Pull the electrical control box holder to remove it. (see CJ_EP_009).</p>	 <p>CJ_EP_009</p>

Note: This section is for reference only. Actual unit appearance may vary.

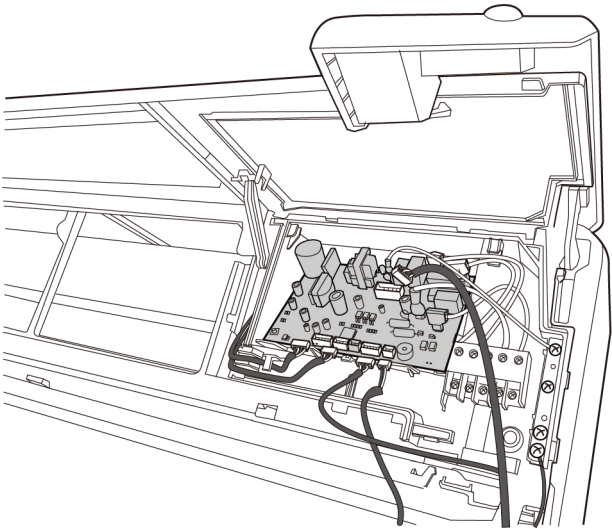
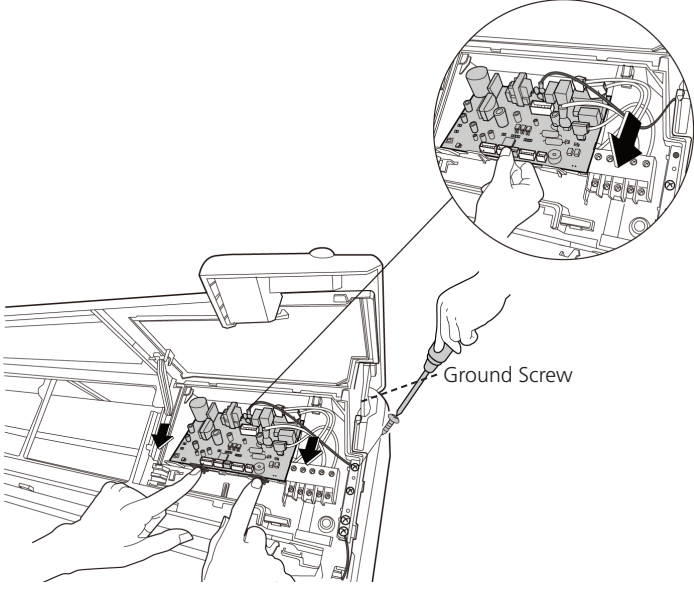
Procedure	Illustration
<p>4) Disconnect the wires. (see CJ_EP_010)</p>	 <p style="text-align: center;">CJ_EP_010</p>
<p>5) Remove one screw used for the ground connection. (see CJ_EP_011)</p> <p>6) Pull two clips of the electronic control box along the direction shown in the right picture to remove the main control board. (see CJ_EP_011)</p> <p>(If you want to repair the main control board assembly, perform step 1 to step 6.; If you want to repair the electrical control box subassembly, perform the following steps)</p>	 <p style="text-align: center;">CJ_EP_011</p>

Note: This section is for reference only. Actual unit appearance may vary.

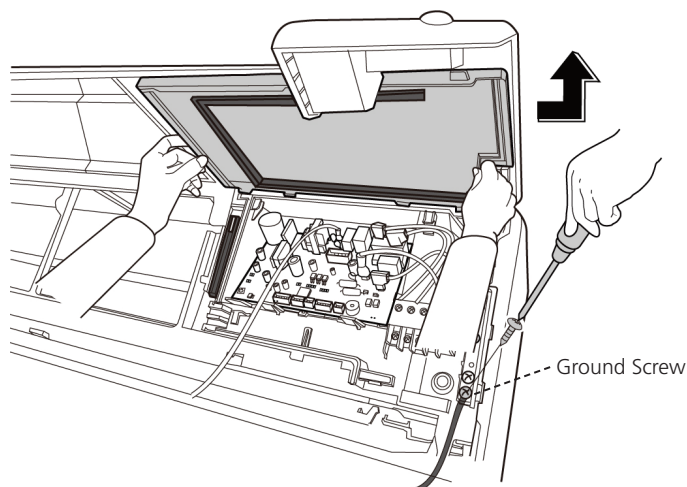
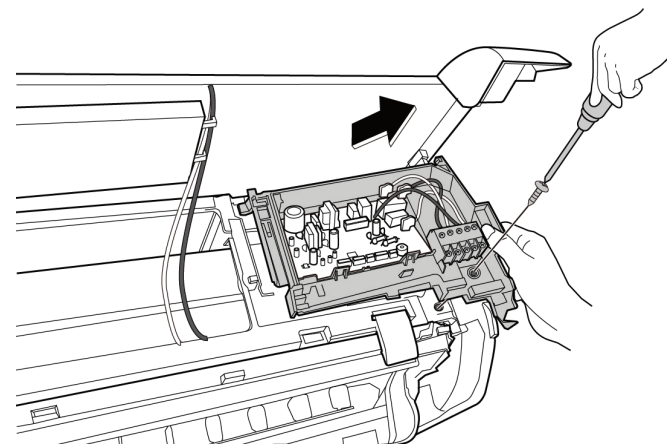
Procedure	Illustration
<p>7) Remove the other screw used for the ground connection.(see CJ_EP_012)</p> <p>8) Collapse the mandril.(see CJ_EP_012)</p> <p>9) Pull the cover of electronic control box along the direction indicated in right image to remove it.(see CJ_EP_012)</p>	 <p style="text-align: center;">CJ_EP_012</p>
<p>10) Remove one fixing screw then pull out the electronic control box subassembly. (see CJ_EP_013)</p>	 <p style="text-align: center;">CJ_EP_013</p>

Note: This section is for reference only. Actual unit appearance may vary.

2.3 Fan motor and fan

Note: Remove the front panel (refer to 2.1 Front panel). before disassembling fan motor and fan.

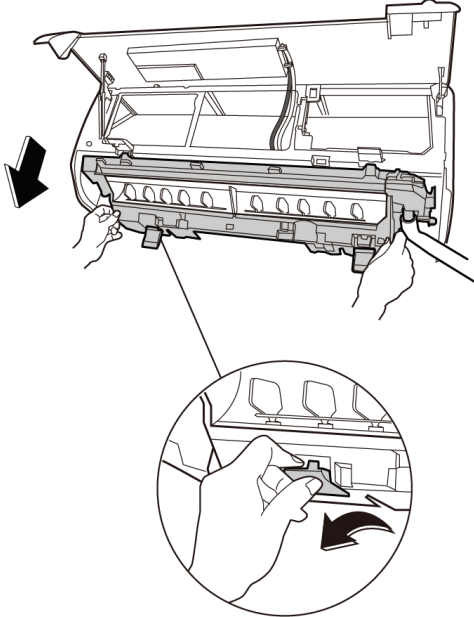
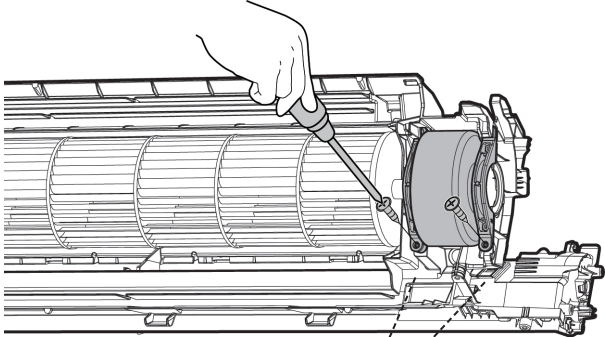
Procedure	Illustration
<p>1) Open two stop blocks of chassis assembly(below). (see CJ_EP_014)</p> <p>2) Remove chassis assembly(below) along the direction shown in the right picture (see CJ_EP_014)</p>	 <p style="text-align: center;">CJ_EP_014</p>
<p>3) Remove the two screws and remove the fixing board of the fan motor (see CJ_EP_015).</p>	 <p style="text-align: center;">Screws</p> <p style="text-align: center;">CJ_EP_015</p>

Note: This section is for reference only. Actual unit appearance may vary.

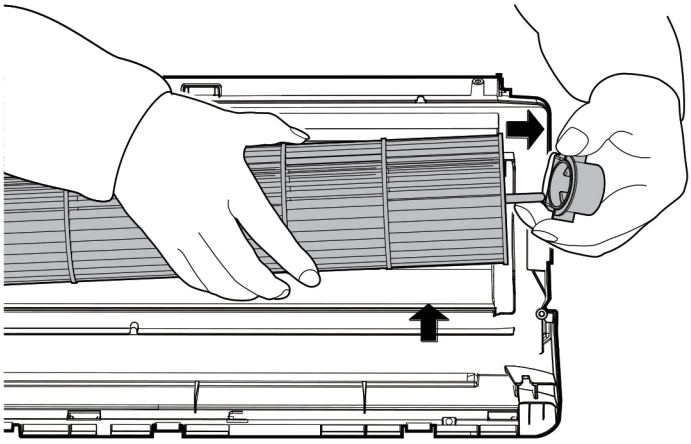
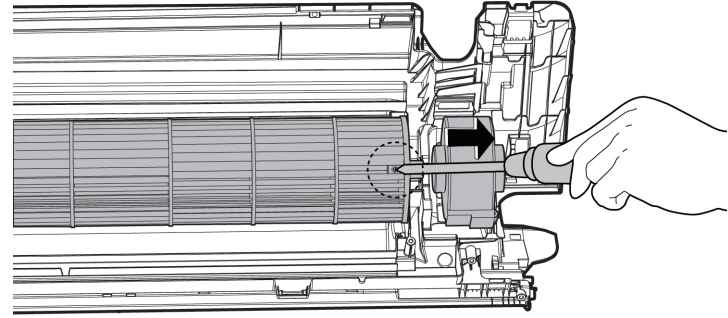
Procedure	Illustration
<p>4) Remove the bearing sleeve (see CJ_EP_016).</p>	 <p style="text-align: center;">CJ_EP_016</p>
<p>5) Remove the fixing screw (see CJ_EP_017).</p> <p>6) Pull out the fan motor and fan assembly from the side.</p>	 <p style="text-align: center;">CJ_EP_017</p>

Note: This section is for reference only. Actual unit appearance may vary.

2.4 Step motor

Note: Remove the front panel and chassis assembly(below) (refer to 2.1 Front panel and 2.3 Fan motor and fan) before disassembling step motor.

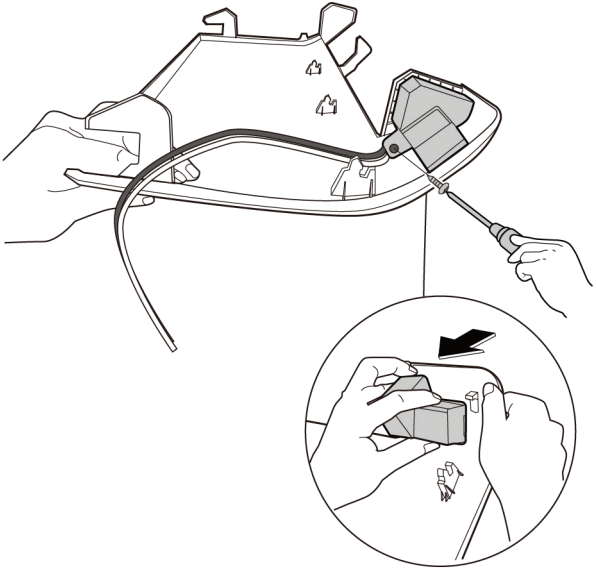
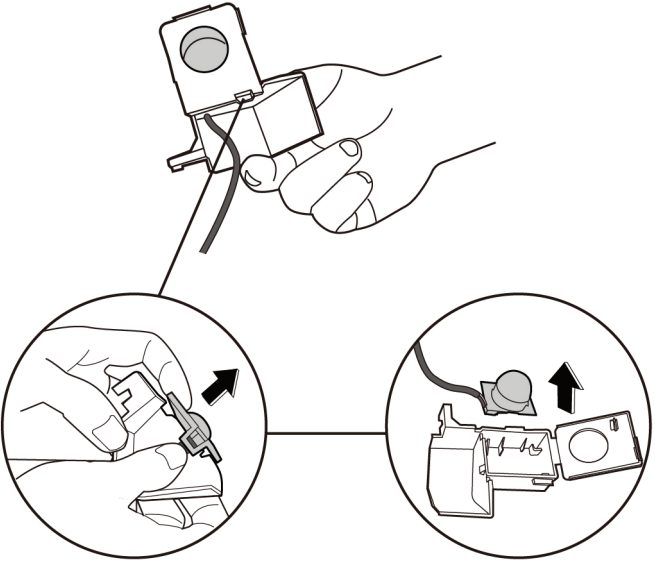
Procedure	Illustration
<p>1) Remove one screw to remove cover of louver motor.(see CJ_EP_018).(for some units)</p> <p>2) Open the cover of louver motor, pull out intelligent eye subassembly.(see CJ_EP_019).(for some units)</p>	 <p style="text-align: center;">CJ_EP_018</p>  <p style="text-align: center;">CJ_EP_019</p>

Note: This section is for reference only. Actual unit appearance may vary.

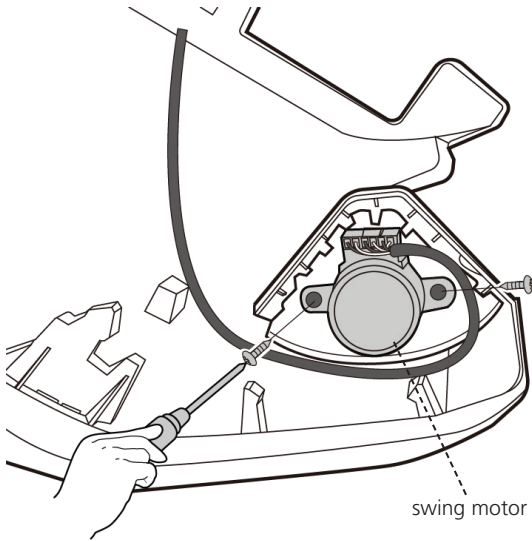
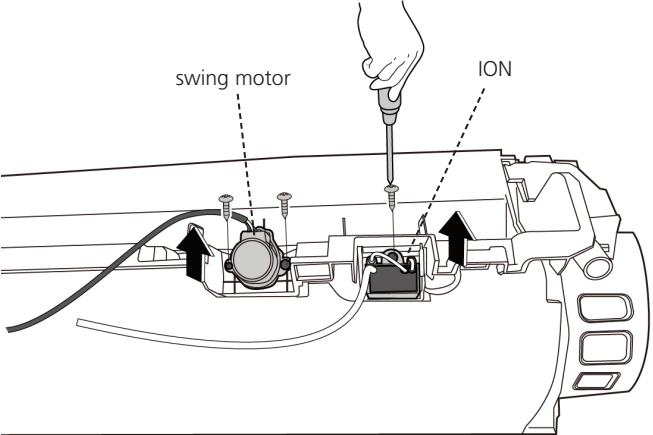
Procedure	Illustration
<p>3) Remove the two screws, then remove the horizontal swing motor(see CJ_EP_020).</p> <p>Note: The horizontal swing motor is located in panel assembly.</p>	 <p style="text-align: center;">CJ_EP_020</p>
<p>4) Remove 2 screws, then remove the vertical swing motor (see CJ_EP_021).(for some units)</p> <p>5) Remove 1 screw, then remove the ionizer generator (see CJ_EP_021).(for some units)</p> <p>Note: The vertical swing motor and ionizer generator are located in chassis assembly(below).</p>	 <p style="text-align: center;">CJ_EP_021</p>

Note: This section is for reference only. Actual unit appearance may vary.

2.5 Drain Hose

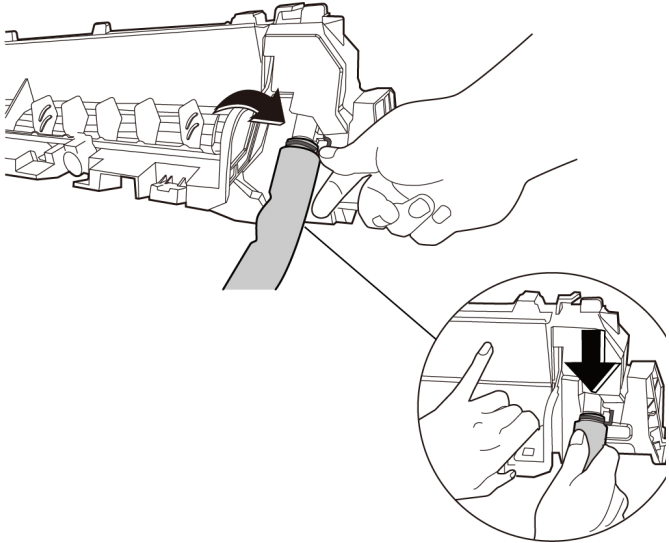
Procedure	Illustration
<p>1) Rotate the fixed wire clockwise indicated in right image. (see CJ_EP_022)</p> <p>2) Pull up the drain hose to remove it. (see CJ_EP_022)</p>	 <p data-bbox="992 890 1125 919">CJ_EP_022</p>

Note: This section is for reference only. Actual unit appearance may vary.

2.6 Evaporator

Note: Remove the front panel, electrical parts and fan (refer to 2.1 Front panel, 2.2 Electrical parts and 2.3 fan motor and fan) before disassembling evaporator.

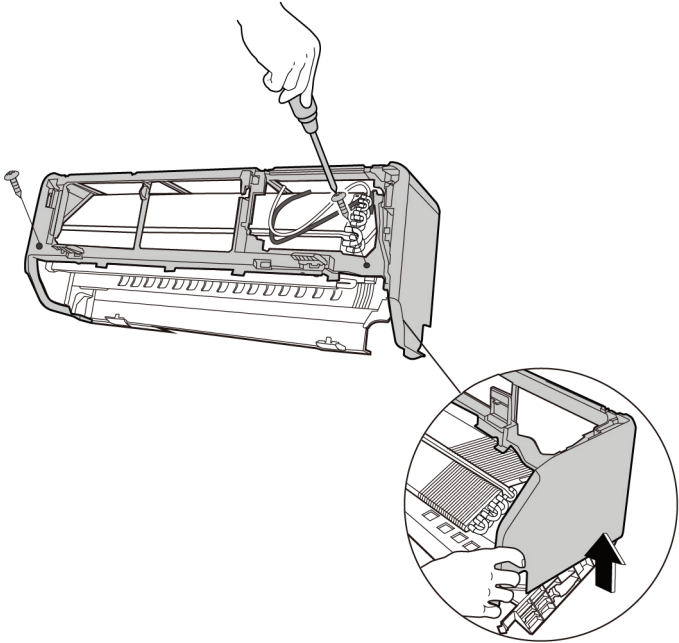
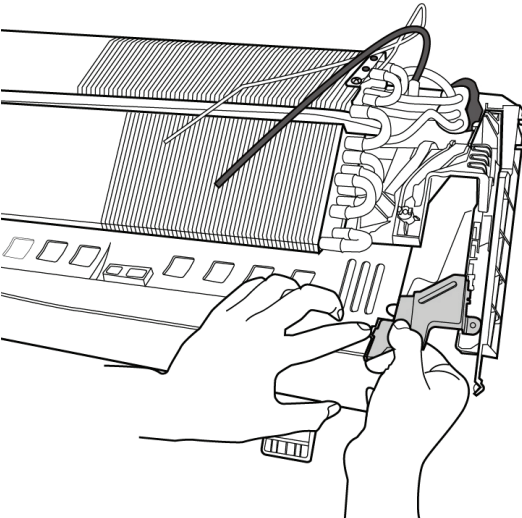
Procedure	Illustration
<p>1) Remove the 2 screws then remove the panel frame assembly.(see CJ_EP_023)</p>	 <p>CJ_EP_023</p>
<p>2) Disassemble the pipe clamp board.(see CJ_EP_024)</p>	 <p>CJ_EP_024</p>

Note: This section is for reference only. Actual unit appearance may vary.

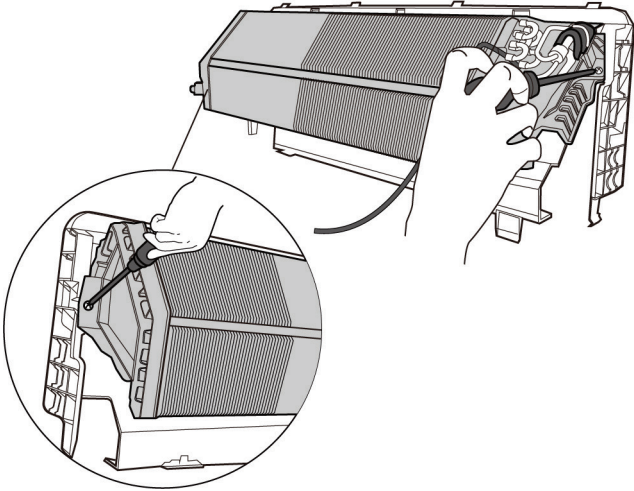
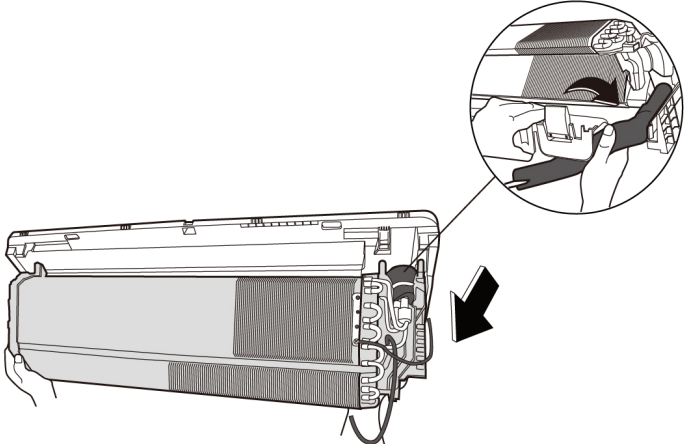
Procedure	Illustration
<p>3) Remove the 1 screw on the evaporator located at the left fixed plate (see CJ_EP_025).</p> <p>4) Remove the 1 screw on the evaporator located on the right side. (see CJ_EP_025).</p>	 <p style="text-align: center;">CJ_EP_025</p>
<p>5) Bend the piping carefully, separate the chassis assembly(above) and the evaporator then take the evaporator out. (see CJ_EP_026)</p>	 <p style="text-align: center;">CJ_EP_026</p>

Note: This section is for reference only. Actual unit appearance may vary.

Outdoor Unit Disassembly

Contents

1.	Outdoor Unit Table	2
2.	Dimension	3
3.	Outdoor Unit Disassembly	24
3.1	Panel Plate.....	24
3.2	Electrical Parts	49
3.3	Fan Assembly	68
3.4	Fan Motor	69
3.5	Sound blanket.....	70
3.6	Four-way valve.....	71
3.7	Compressor	72

Outdoor Unit Model	Panel Plate	PCB Board
	X230	PCB Board 11
A-VMH06SV-1	X330	PCB Board 9
A-VMH09SV-1	X230	PCB Board 9
A-VMH12SV-1	X330	PCB Board 9
	X230	PCB Board 9
A-VMH18SV-1	X430	PCB Board 6
	X430	PCB Board 6
	D30	PCB Board 6
A-VMH24SV-1	D30	PCB Board 12
A-VMH30SV-1	D30	PCB Board 12
A-VMH36SV-1	D30	PCB Board 12

6. Panel Plate D30

24k-36k

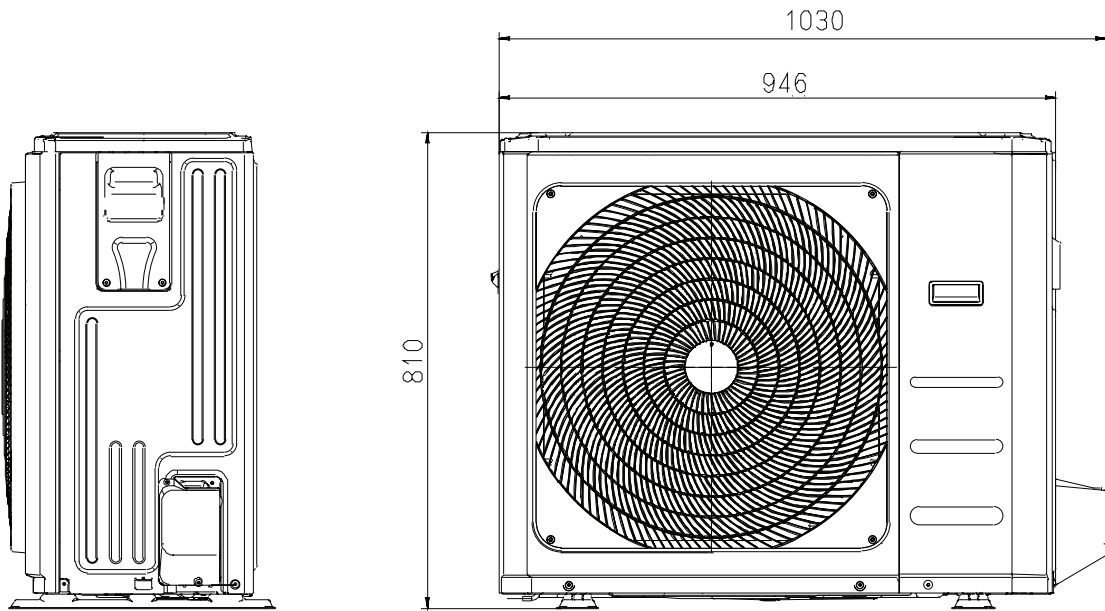

DETAIL A
SCALE 1 : 2

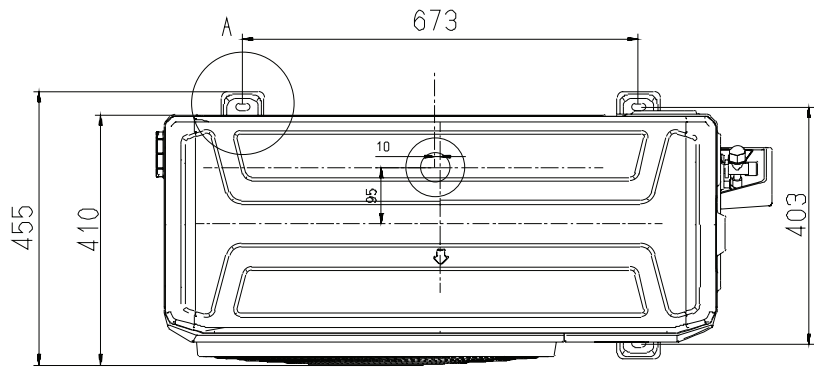
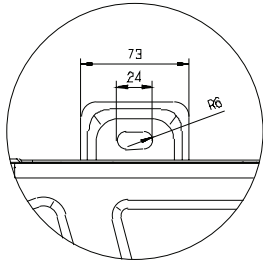

For US models:

24k-36k

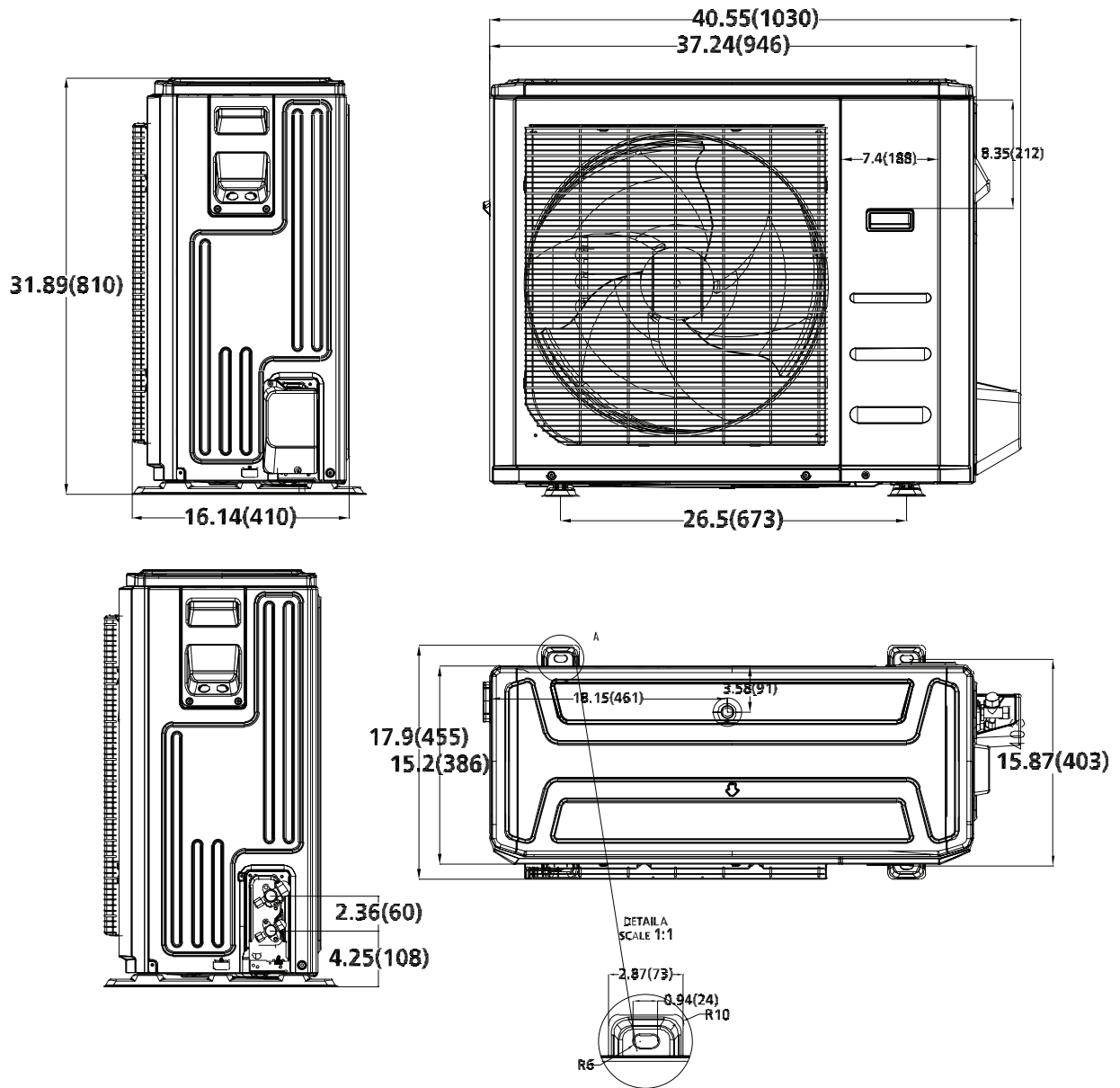

9. Panel Plate X330

9k-12k

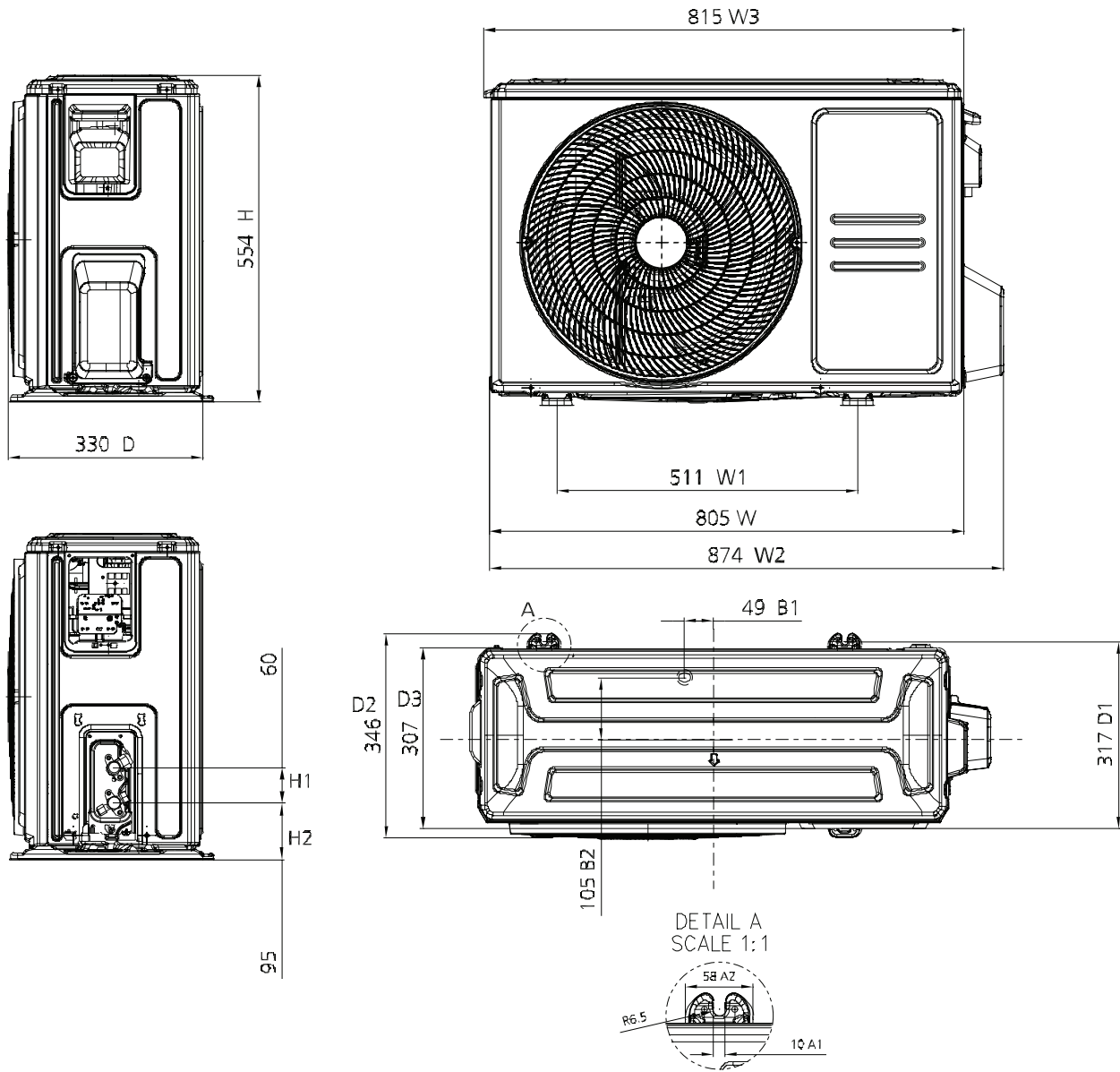

For US models(Rounded grille): 9k-12k

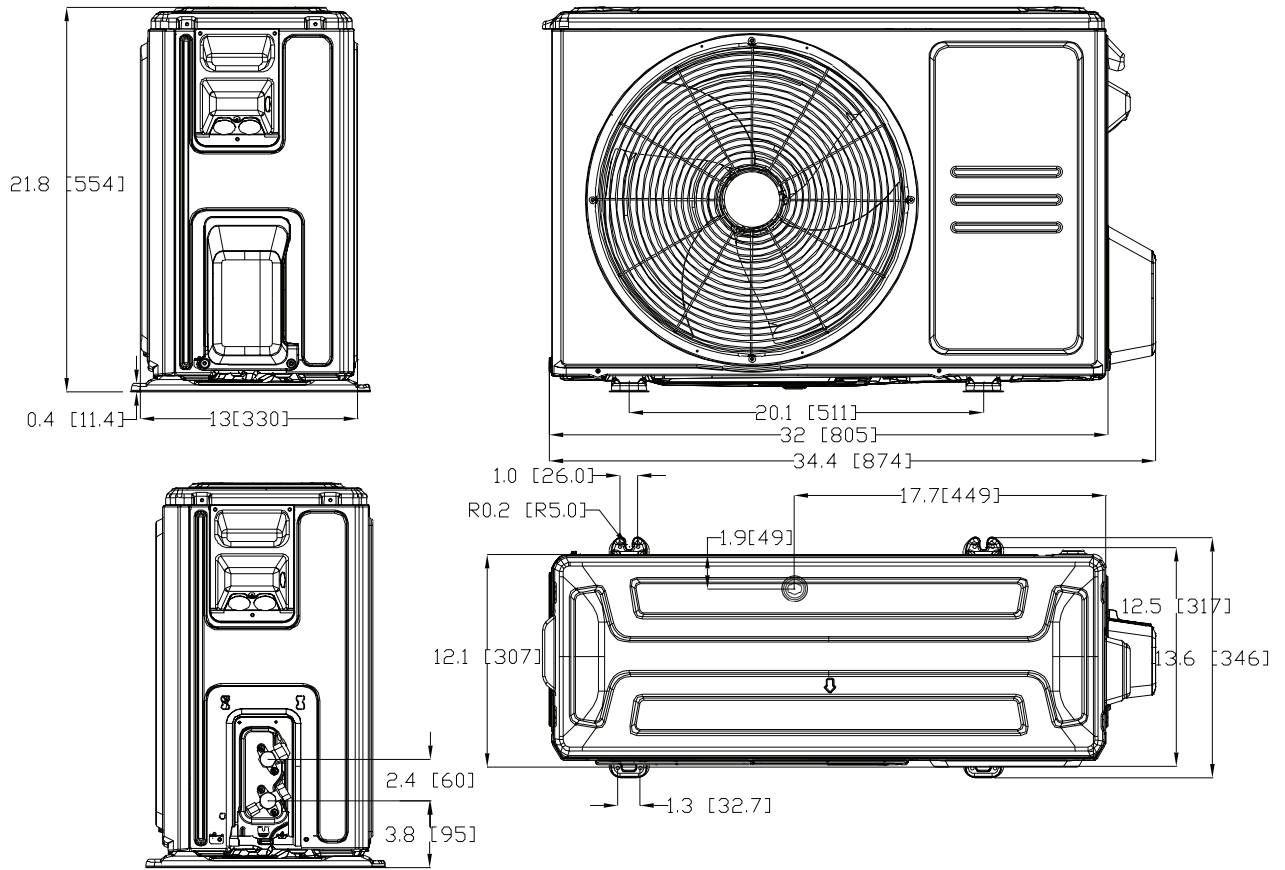

10. Panel Plate X430

18k

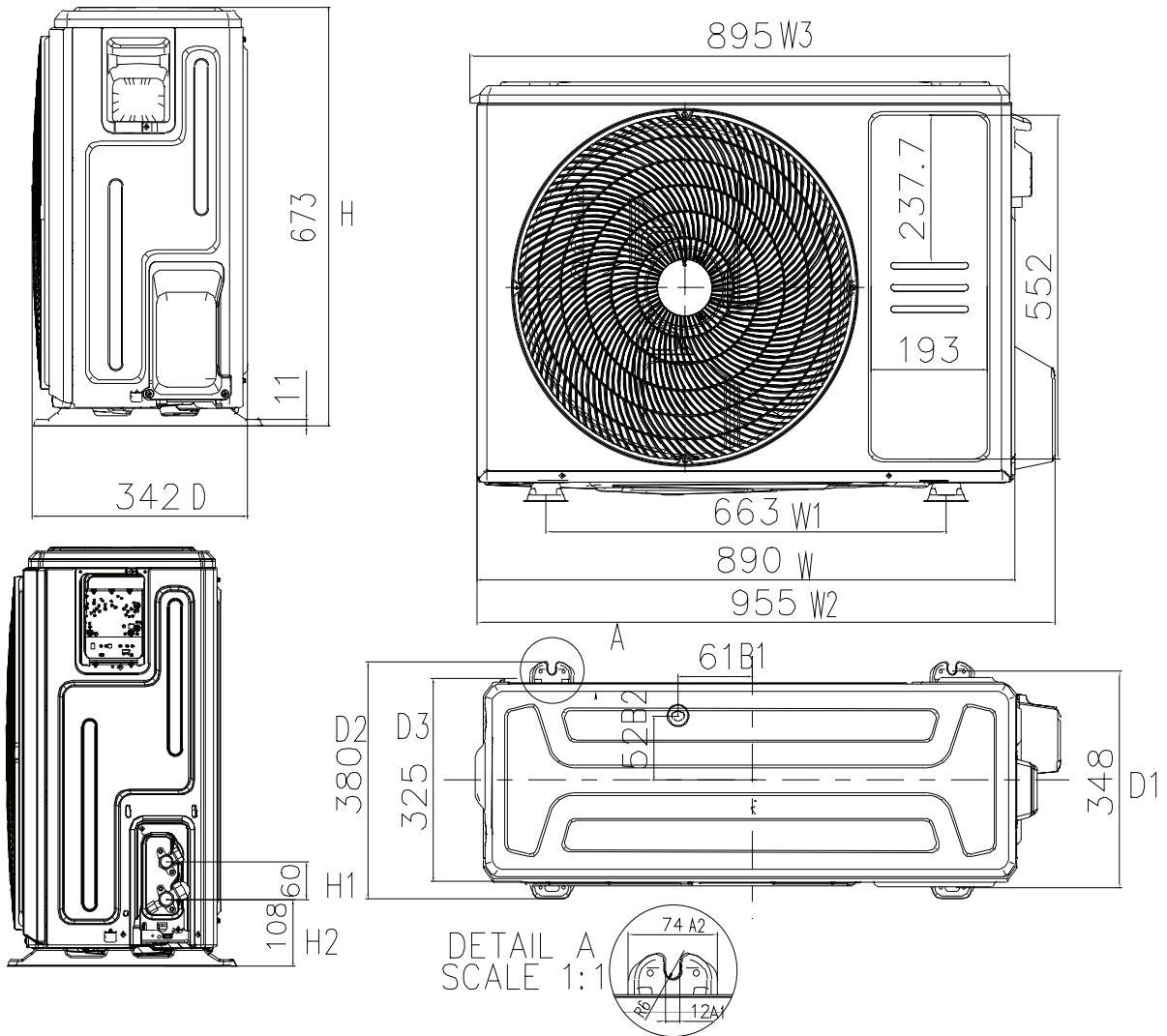

For US models(Rounded grille): 18k

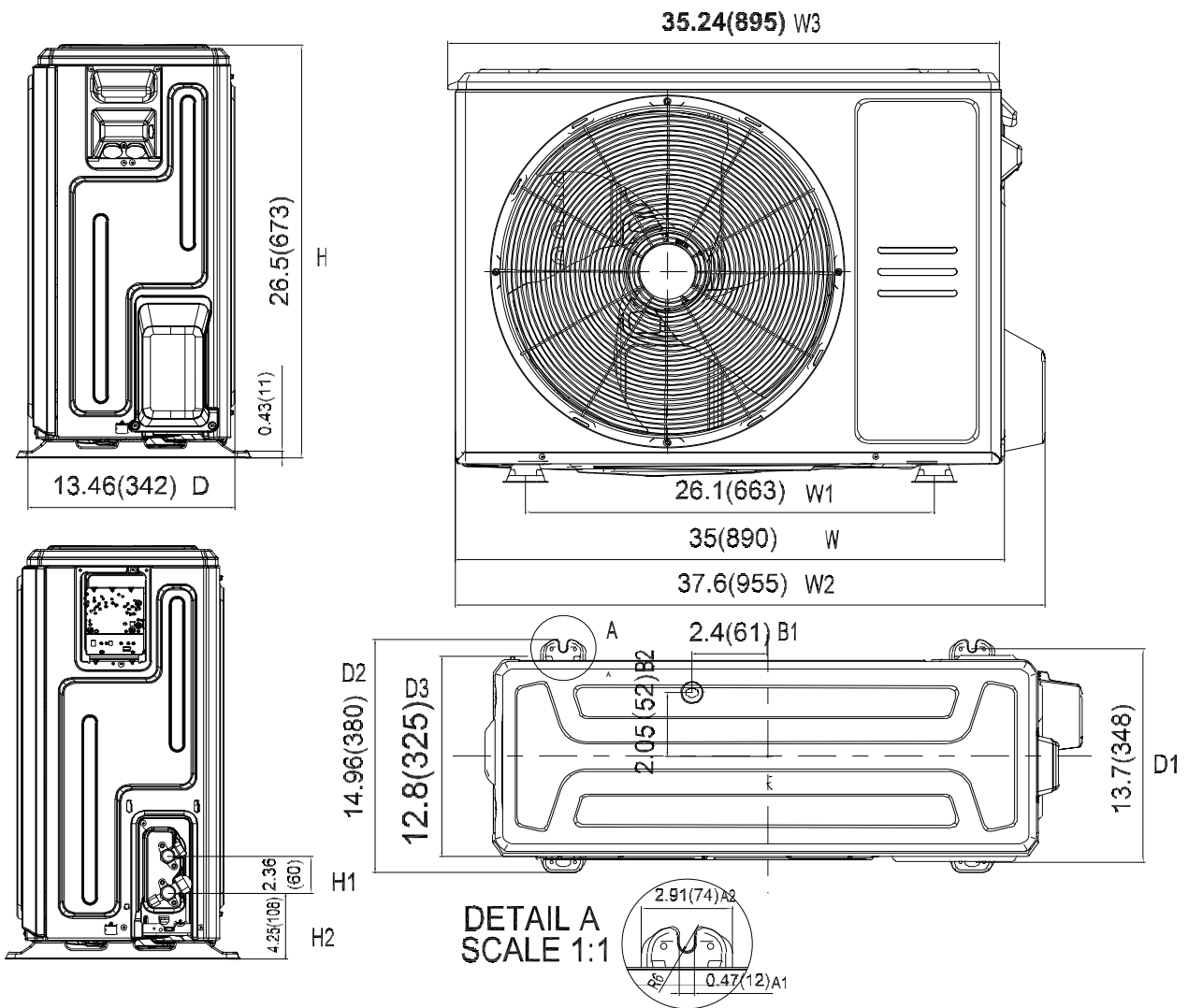

5. D30 24k-36k

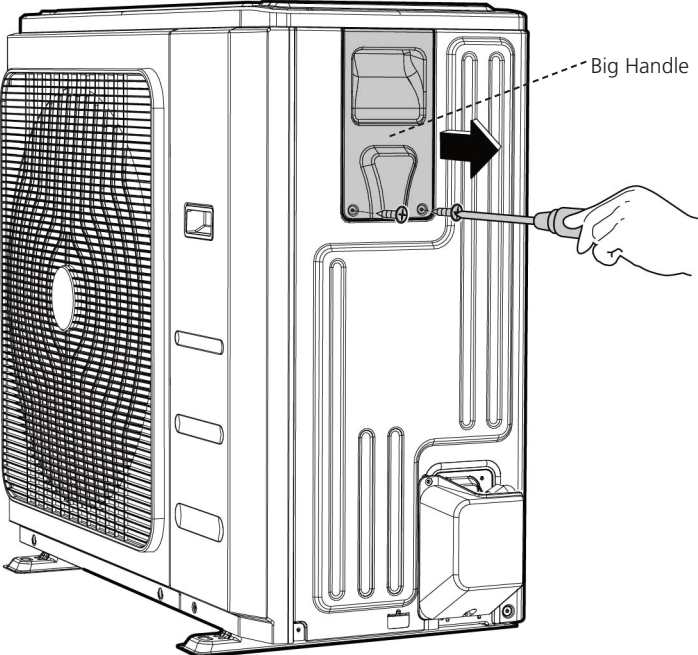
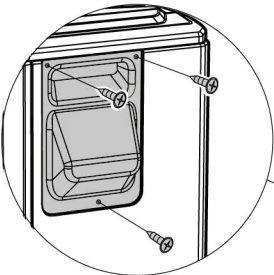
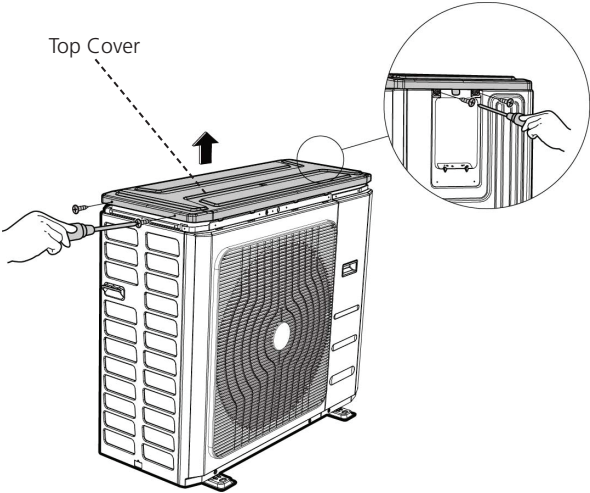
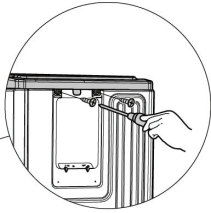
Procedure	Illustration
<p>1) Turn off the air conditioner and the power breaker.</p> <p>2) Remove the screws of the big handle and then remove the big handle (2 screws) (see CJ_D30_001).</p>	 <p>Big Handle</p>  <p>For US models (3 screws)</p> <p>CJ_D30_001</p>
<p>3) Remove the screws of the top cover and then remove the top cover (4 screws). Two of the screws is located underneath the big handle (see CJ_D30_002).</p>	 <p>Top Cover</p>  <p>CJ_D30_002</p>

Note: This section is for reference only. Actual unit appearance may vary.

Procedure

Illustration

- 4) Remove the screws of the front right panel and then remove the front right panel (2 screws) (see CJ_D30_003).

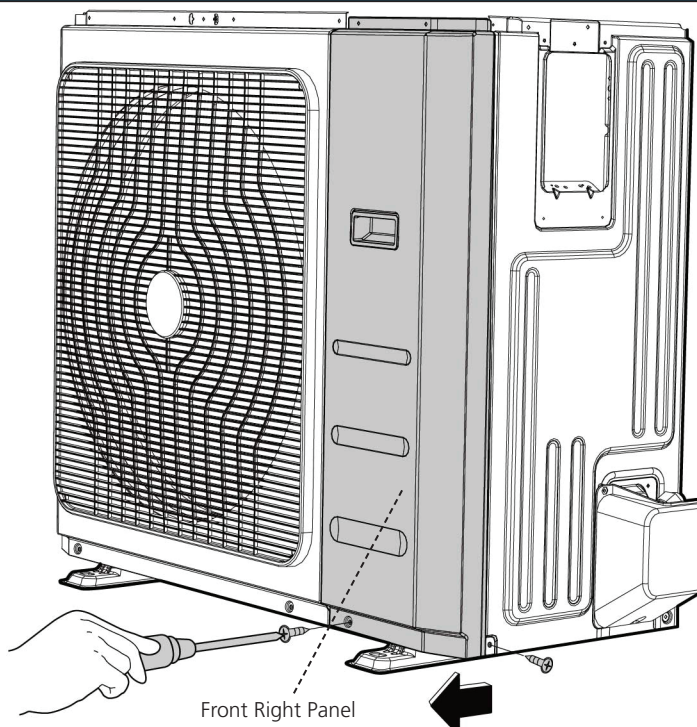

CJ_D30_003

- 5) Remove the screws of the front panel and then remove the front panel (9 screws) (see CJ_D30_004).

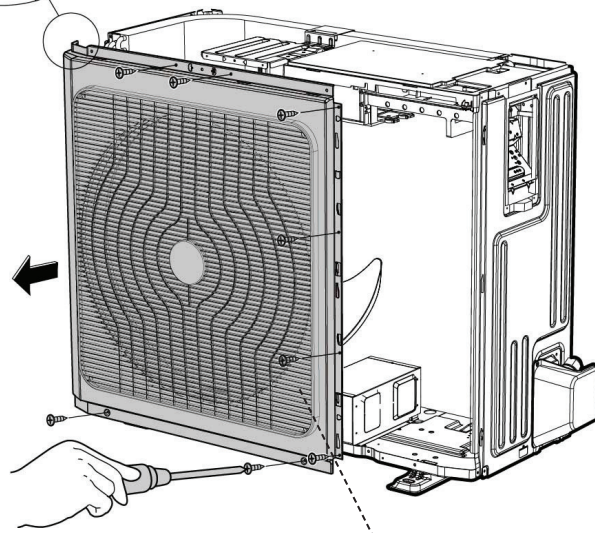
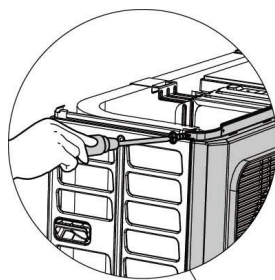

CJ_D30_004

Note: This section is for reference only. Actual unit appearance may vary.

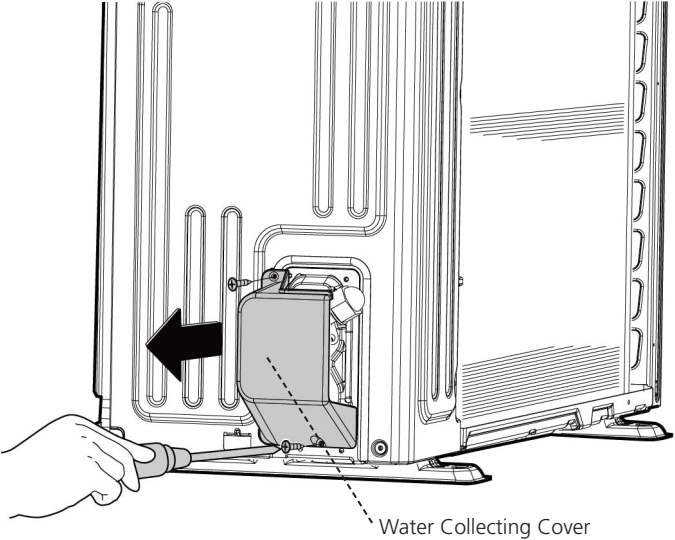
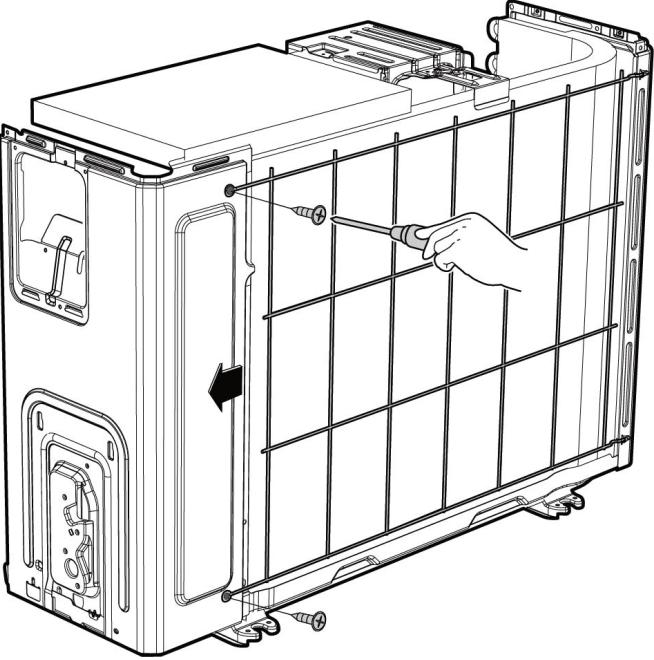
Procedure	Illustration
<p>6) Remove the screws of water collecting cover and then remove the water collecting cover (2 screw) (see CJ_D30_005).</p>	 <p style="text-align: center;">CJ_D30_005</p>
<p>7) Remove the screws of the rear net and then remove the rear net (2 screws) (see CJ_D30_006). (for some models)</p>	 <p style="text-align: center;">CJ_D30_006</p>

Note: This section is for reference only. Actual unit appearance may vary.

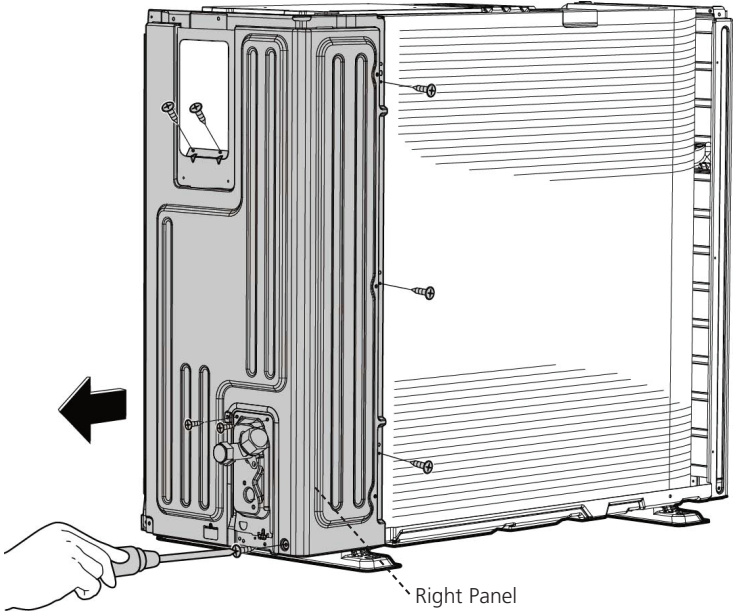
Procedure	Illustration
<p>8) Remove the screws of the right panel and then remove the right panel (8 screws) (see CJ_D30_007).</p>	 <p data-bbox="954 982 1105 1014">CJ_D30_007</p>

Note: This section is for reference only. Actual unit appearance may vary.

7. X230/X330 6k-12k

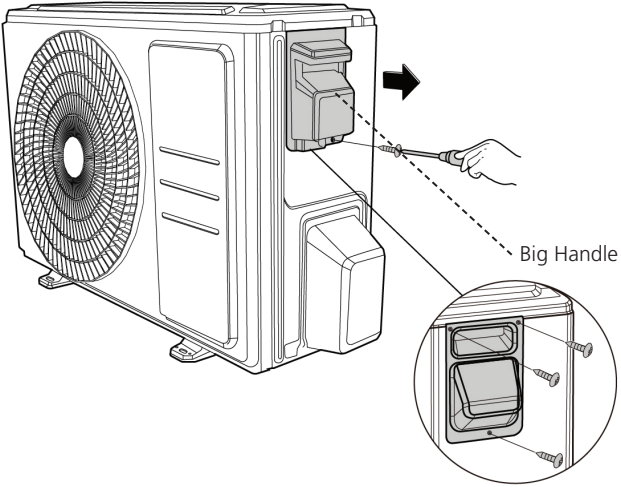
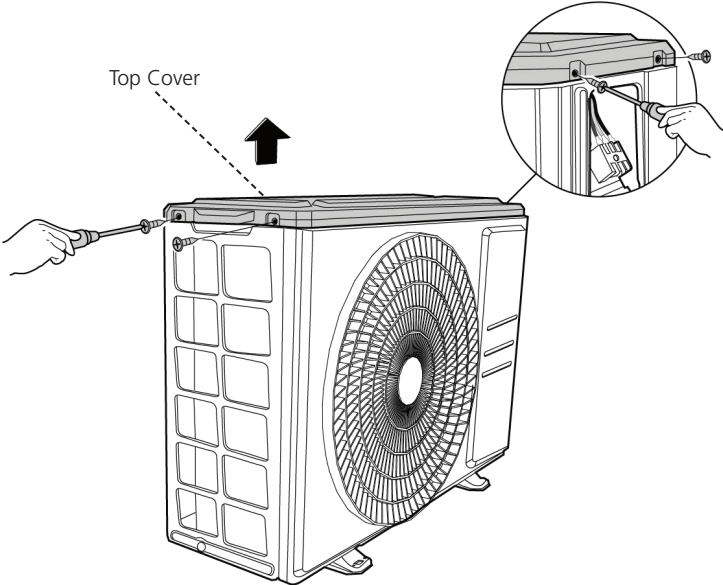
Procedure	Illustration
<p>1) Turn off the air conditioner and the power breaker.</p> <p>2) Remove the screw of the big handle and then remove the big handle (1 screws) (see CJ_X230_001).</p>	 <p style="text-align: center;">CJ_X230_001</p>
<p>3) Remove the screws of the top cover and then remove the top cover (4 screws). One of the screws is located underneath the big handle (see CJ_X230_002).</p>	 <p style="text-align: center;">CJ_X230_002</p>

Note: This section is for reference only. Actual unit appearance may vary.

Procedure	Illustration
-----------	--------------

4) Remove the screws of water collecting cover and then remove the water collecting cover (2 screws) (see CJ_X230_003).

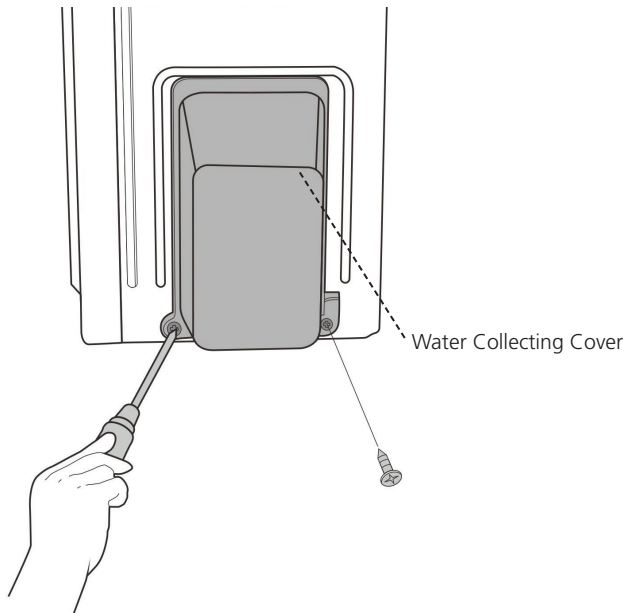

CJ_X230_003

5) Remove the screws of the front panel and then remove the front panel (7 screws(onoff models) or 9 screws(inverter models) (see CJ_X230_004).

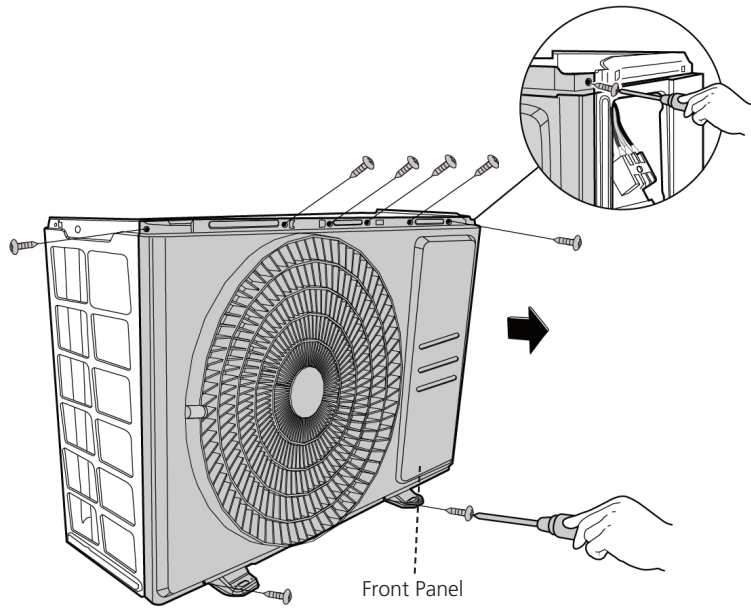

CJ_X230_004

Note: This section is for reference only. Actual unit appearance may vary.

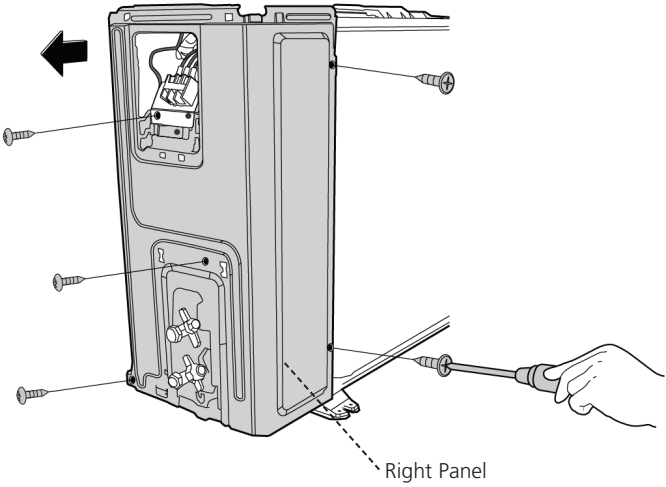
Procedure	Illustration
<p>6) Remove the screws of the right panel and then remove the right panel (5 screws) (see CJ_X230_005).</p>	 <p>CJ_X230_005</p>

Note: This section is for reference only. Actual unit appearance may vary.

8. X430 18k

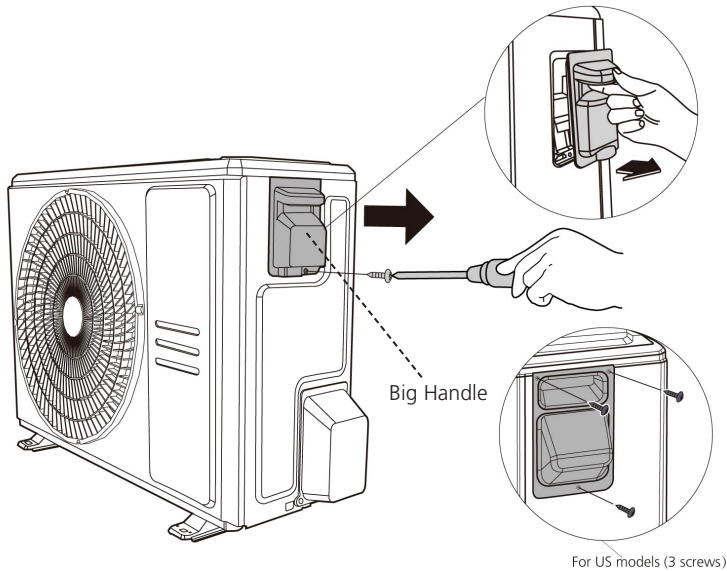
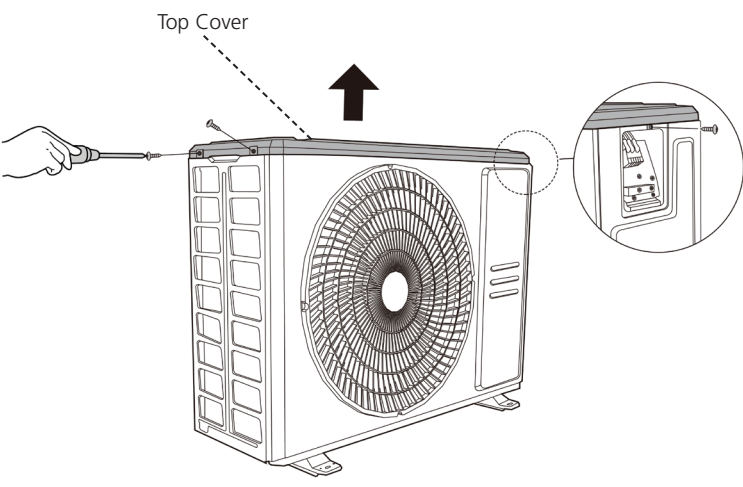
Procedure	Illustration
<p>1) Turn off the air conditioner and the power breaker.</p> <p>2) Remove the screw of the big handle and then remove the big handle (1 screw) (see CJ_X430_001).</p>	 <p>Big Handle</p> <p>For US models (3 screws)</p> <p>CJ_X430_001</p>
<p>3) Remove the screws of the top cover and then remove the top cover (3 screws). One of the screws is located underneath the big handle (see CJ_X430_002).</p>	 <p>Top Cover</p> <p>CJ_X430_002</p>

Note: This section is for reference only. Actual unit appearance may vary.

Procedure

4) Remove the screws of water collecting cover and then remove the water collecting cover (2 screws) (see CJ_X430_003).

Illustration

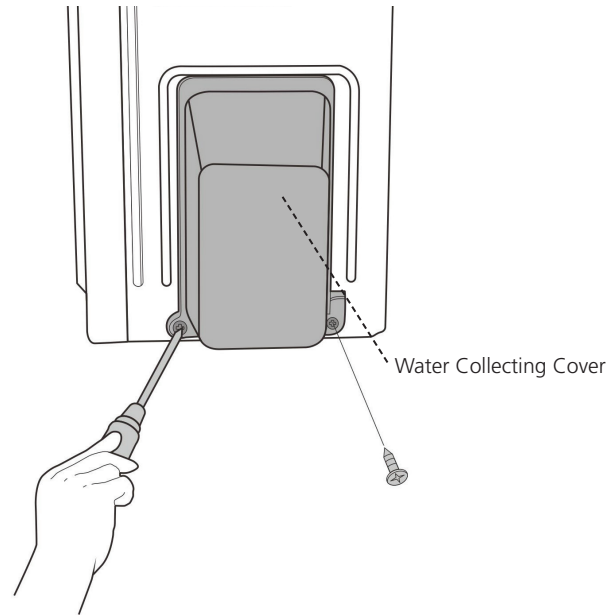

CJ_X430_003

5) Remove the screws of the front panel and then remove the front panel (7 screws(onoff models) or 9 screws(inverter models) (see CJ_X430_004).

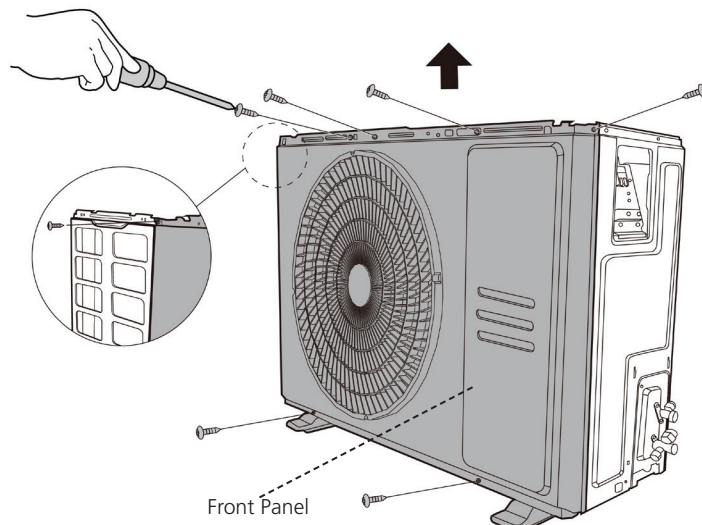

CJ_X430_004

Note: This section is for reference only. Actual unit appearance may vary.

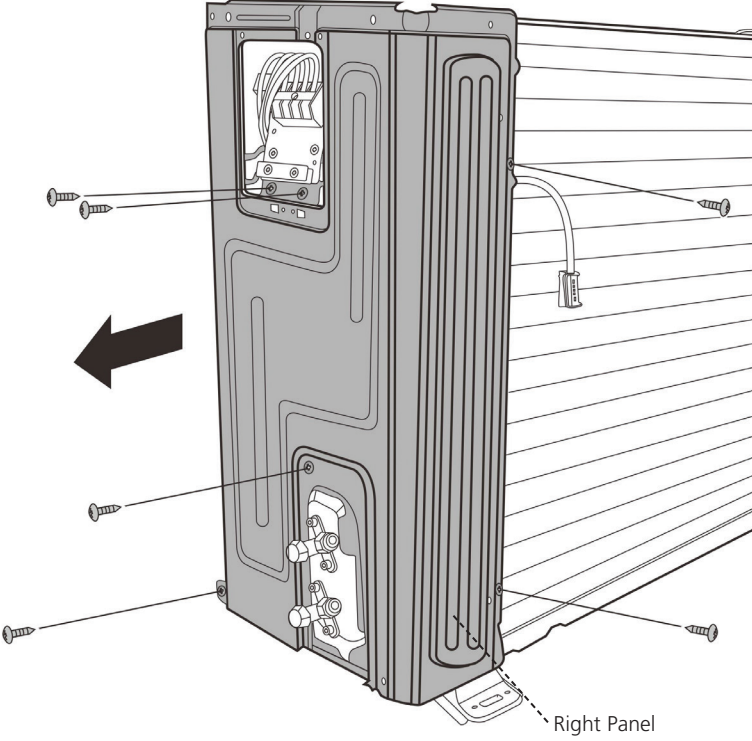
Procedure	Illustration
<p>6) Remove the screws of the right panel and then remove the right panel (6 screws) (see CJ_X430_005).</p>	 <p data-bbox="941 1050 1112 1081">CJ_X430_005</p>

Note: This section is for reference only. Actual unit appearance may vary.

3.2 Electrical parts

⚠ WARNING: Antistatic gloves must be worn when you disassemble the electronic box.

Note: Remove the air outlet grille(refer to 3.1 Panel Plate) before disassembling electrical parts.

i) PCB for ON-OFF Models

1. PCB board 1

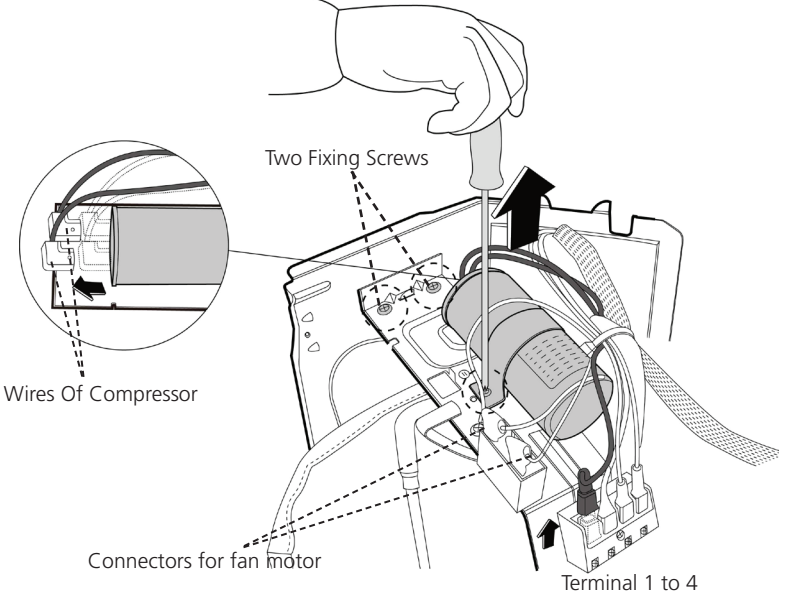
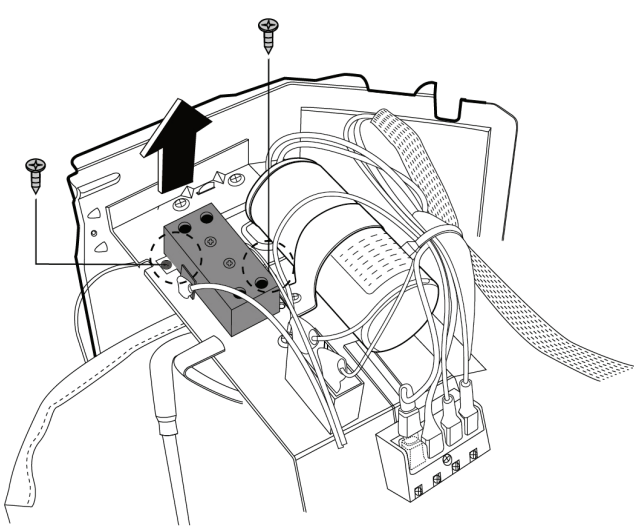
Procedure	Illustration
<ol style="list-style-type: none">1) Remove the two screws fixed the electronic control board (see CJ_ODU_PCB_001).2) Disconnect the connectors for fan motor. (Blue wire, yellow wire, red wire, brown wire and black wire. The blue wire and red wire are on the capacitor. The black wire connects with terminal 4.) (see CJ_ODU_PCB_001)3) Disconnect the wires connected to the compressor. (Black wire connects with terminal 1, blue wire and red wire connect with the compressor capacitor) (see CJ_ODU_PCB_001)4) Disconnect the wires connected to 4-way valve. (Blue wires on terminal 2&3) (see CJ_ODU_PCB_001)5) Remove the fixing screw of the compressor capacitor, then pull it out (see CJ_ODU_PCB_001)6) Remove the electrical parts (see CJ_ODU_PCB_001)7) For models with AC conductor, remove 2 screws of it showed in the figure.	 <p style="text-align: center;">CJ_ODU_PCB_001-01</p>  <p style="text-align: center;">CJ_ODU_PCB_001-02</p>

Note: This section is for reference only. Actual unit appearance may vary.

Procedure

Illustration

8) For models with subzero refrigeration control board, remove 3 screws of it showed in the figure.

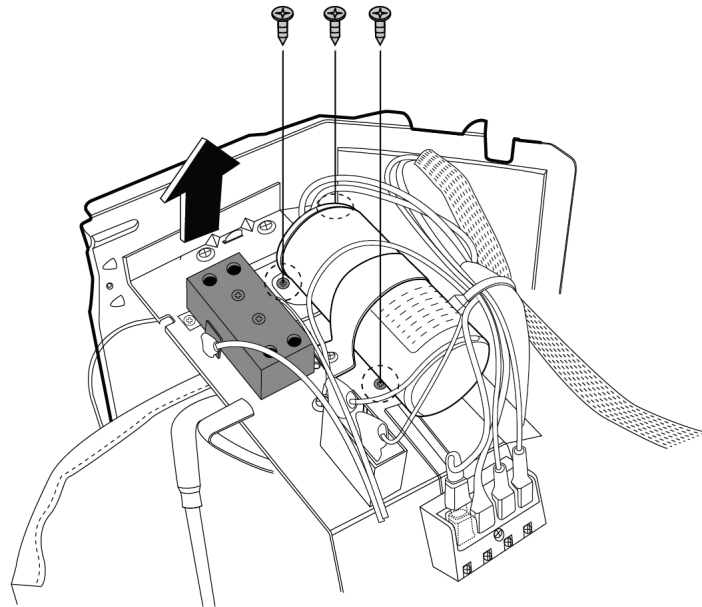

CJ_ODU_PCB_001-03

9) The subzero refrigeration control board is in the back of the metal sheet.

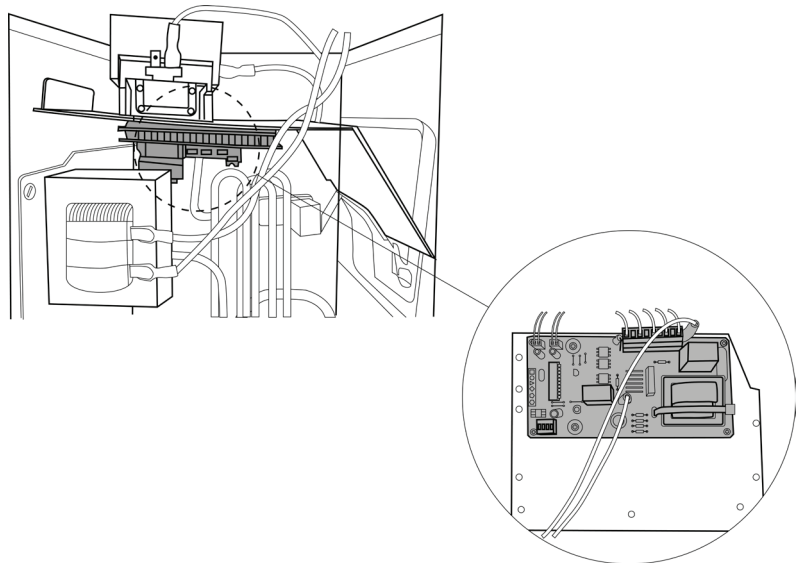

CJ_ODU_PCB_001-04

Note: This section is for reference only. Actual unit appearance may vary.

2. PCB board 2

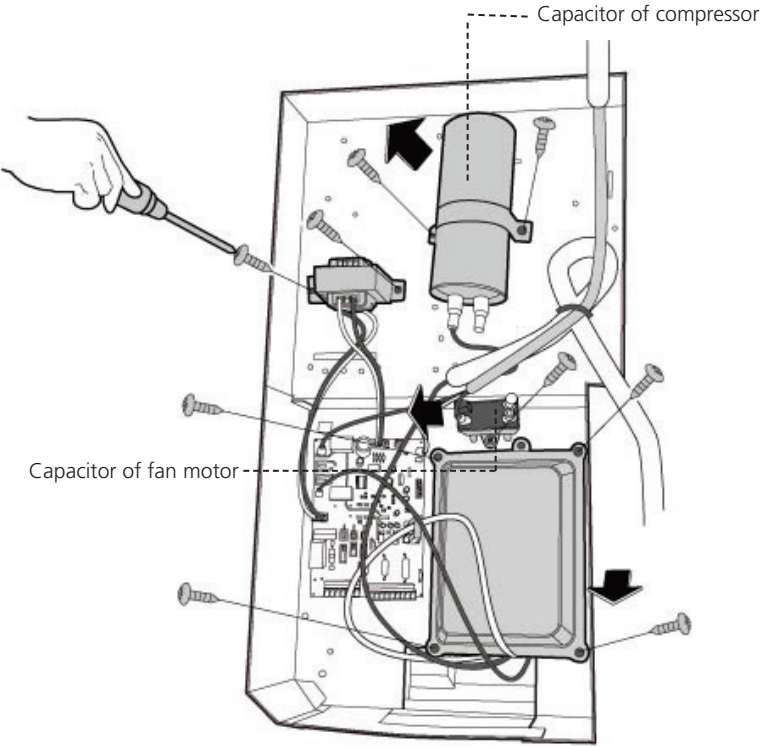
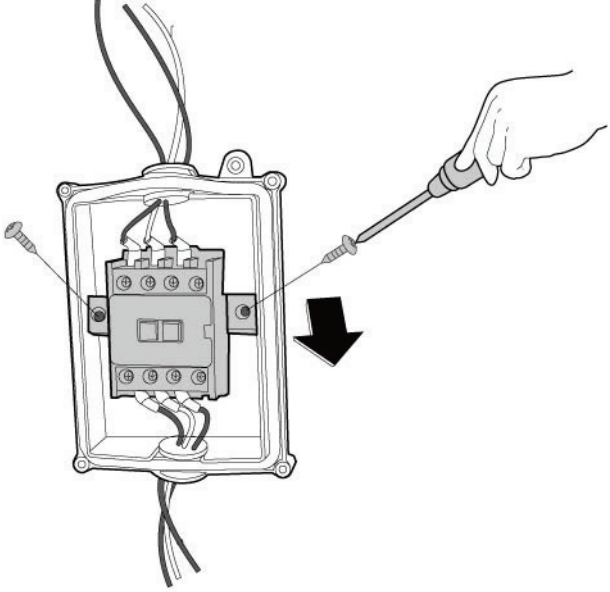
Procedure	Illustration
<p>1) Remove the fixing screws of the compressor capacitor, then pull it out (see CJ_ODU_PCB_002-1)</p> <p>2) Remove 2 screws of the transformer and then remove it. (see CJ_ODU_PCB_002-1)</p> <p>3) Remove the fixing screws of the fan motor capacitor, then remove it. (see CJ_ODU_PCB_002-1)</p> <p>4) Remove the 4 screws of the electronic installing box and then remove it. (see CJ_ODU_PCB_002-1) (for some models)</p>	 <p>The diagram shows a hand using a screwdriver to remove screws from the PCB board. A dashed line points to the 'Capacitor of compressor' at the top. Another dashed line points to the 'Capacitor of fan motor' in the middle. Arrows indicate the removal of the transformer and the electronic installing box.</p> <p style="text-align: center;">CJ_ODU_PCB_002-1</p>
<p>5) Remove the 2 screws of the AC contactor and then remove it. (see CJ_ODU_PCB_002-2)</p>	 <p>The diagram shows a hand using a screwdriver to remove screws from the AC contactor. An arrow indicates the removal of the contactor.</p> <p style="text-align: center;">CJ_ODU_PCB_002-2</p>

Note: This section is for reference only. Actual unit appearance may vary.

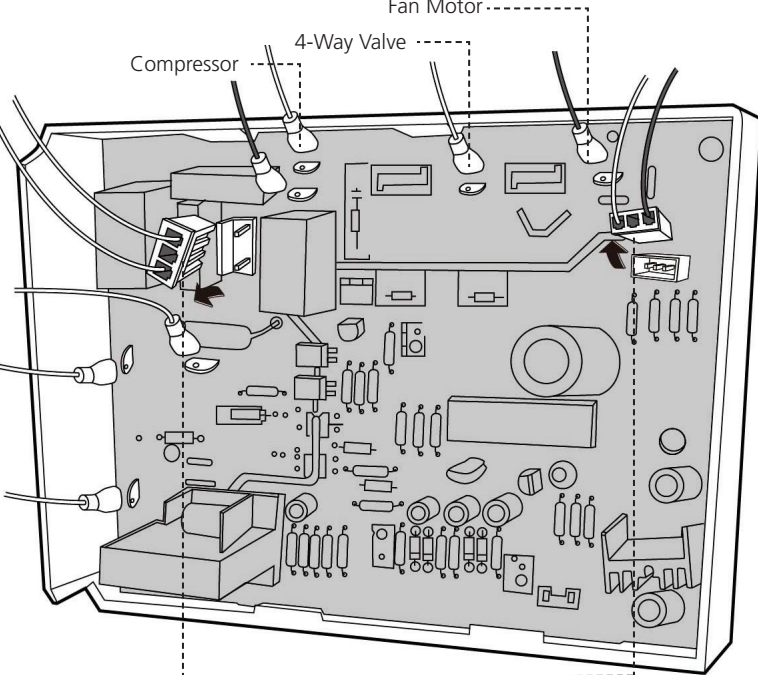
Procedure	Illustration
<p>6) Disconnect the wires connected to the compressor. (Red wire connects with PCB board, others connects with terminals) (see CJ_ODU_PCB_002-3) (For some models)</p> <p>7) Disconnect the connectors for fan motor. (Blue wire, red wire, brown wire and black wire. The blue wire and brown wire are on the capacitor. The black wire connects with a terminal. And the red wire is on the board.) (see CJ_ODU_PCB_002-3)(For some models)</p> <p>8) Disconnect the wires connected to 4-way valve. (see CJ_ODU_PCB_002-3)(For some models)</p> <p>9) Disconnect the wires connected to the transformer. (see CJ_ODU_PCB_002-3)(For some models)</p> <p>10) Disconnect the other wires connected to terminals. (see CJ_ODU_PCB_002-3)(For some models)</p> <p>11) Remove the PCB board. (see CJ_ODU_PCB_002-3)(For some models)</p>	 <p>The illustration shows a top-down view of the PCB board CJ_ODU_PCB_002-3. It is populated with various electronic components including capacitors, resistors, and integrated circuits. Several wires are connected to the board and are labeled with dashed lines: a red wire connects to the Compressor, a blue wire connects to the Fan Motor, a brown wire connects to the Fan Motor, a black wire connects to a terminal, and a red wire connects to the board. A 4-Way Valve and a Transformer are also labeled. The board is shown within a rectangular frame representing the unit's chassis.</p>

Note: This section is for reference only. Actual unit appearance may vary.

3. PCB board 3

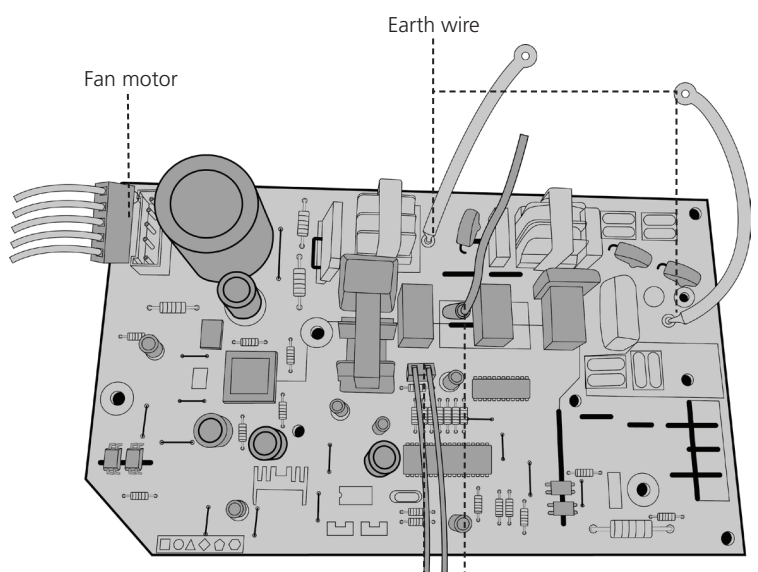
Procedure	Illustration
<p>1) Disconnect the connectors for fan motor (see CJ_ODU_PCB_003).</p> <p>2) Disconnect the wires connected to the compressor (see CJ_ODU_PCB_003).</p> <p>3) Disconnect the wires connected to Pipe temperature sensor (see CJ_ODU_PCB_003).</p> <p>4) Disconnect the earth wire (see CJ_ODU_PCB_003).</p> <p>5) Remove the PCB board (see CJ_ODU_PCB_003).</p>	 <p>The illustration shows a top-down view of the PCB board CJ_ODU_PCB_003. It features a fan motor, a pipe temperature sensor, and a compressor. Wires are shown connected to these components and are labeled with dashed lines: a red wire connects to the Fan motor, a blue wire connects to the Fan motor, a brown wire connects to the Fan motor, a black wire connects to a terminal, and a red wire connects to the board. An Earth wire is also labeled. The board is shown within a rectangular frame representing the unit's chassis.</p>

Note: This section is for reference only. Actual unit appearance may vary.

ii) PCB for Inverter Models

4. PCB board 4

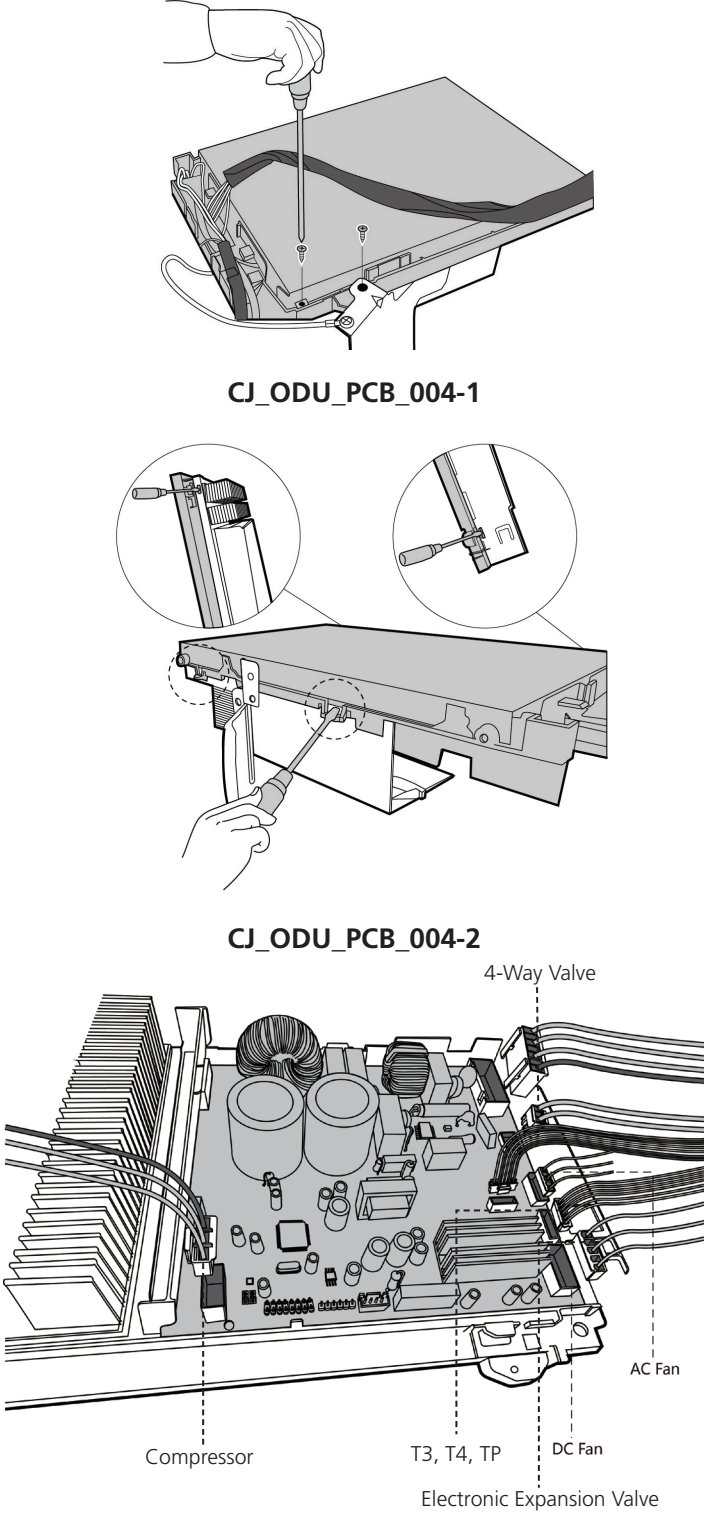
Procedure	Illustration
<ol style="list-style-type: none"> 1) Remove the screws of the top cover. (2 screws) (see CJ_ODU_PCB_004-1). 2) Unfix the hooks and then open the electronic control box cover (4 hooks) (see CJ_ODU_PCB_004-2). 3) Disconnect the connector for fan motor from the electronic control board (see CJ_ODU_PCB_004-3). 4) Remove the connector for the compressor (see CJ_ODU_PCB_004-3). 5) Pull out the two blue wires connected with the four way valve (CJ_ODU_PCB_004-3). 6) Pull out connectors of the condenser coil temp. sensor(T3), outdoor ambient temp. sensor(T4) and discharge temp. sensor(TP) (CJ_ODU_PCB_004-3). 7) Disconnect the electronic expansion valve wire (CJ_ODU_PCB_004-3). 8) Then remove the electronic control board. 	 <p style="text-align: center;">CJ_ODU_PCB_004-1</p> <p style="text-align: center;">CJ_ODU_PCB_004-2</p> <p style="text-align: center;">CJ_ODU_PCB_004-3</p>

Note: This section is for reference only. Actual unit appearance may vary.

5. PCB board 5

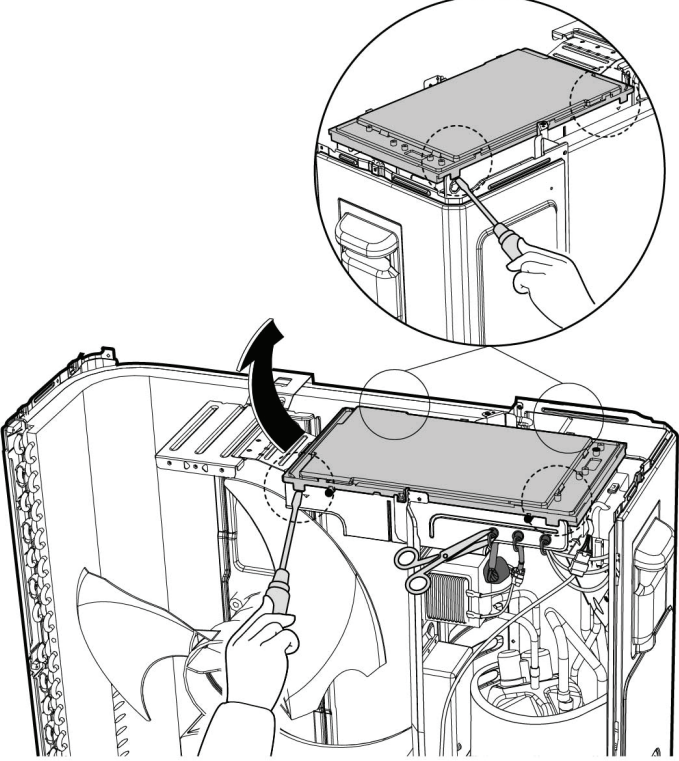
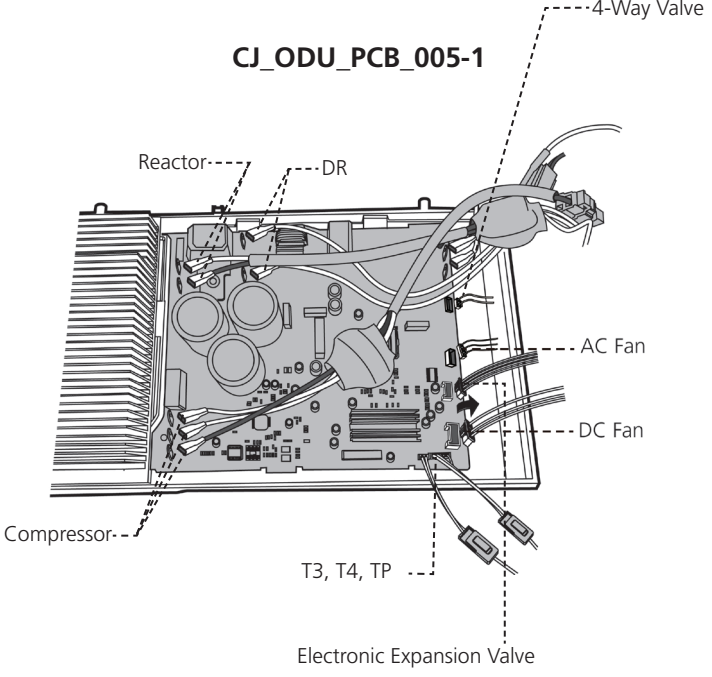
Procedure	Illustration
<p>1) Unfix the hooks and then open the electronic control box cover (4 hooks) (see CJ_ODU_PCB_005-1).</p>	
<p>2) Disconnect the connector for fan motor from the electronic control board (see CJ_ODU_PCB_005-2).</p> <p>3) Remove the connector for the compressor (see CJ_ODU_PCB_005-2).</p> <p>4) Pull out the two blue wires connected with the four way valve (see CJ_ODU_PCB_005-2).</p> <p>5) Pull out connectors of the condenser coil temp. sensor(T3), outdoor ambient temp. sensor(T4) and discharge temp. sensor(TP) (see CJ_ODU_PCB_005-2).</p> <p>6) Disconnect the electronic expansion valve wire (see Fig CJ_ODU_PCB_005-2).</p> <p>7) Then remove the electronic control board.</p>	 <p style="text-align: center;">CJ_ODU_PCB_005-1</p> <p style="text-align: center;">CJ_ODU_PCB_005-2</p>

Note: This section is for reference only. Actual unit appearance may vary.

5. PCB board 6

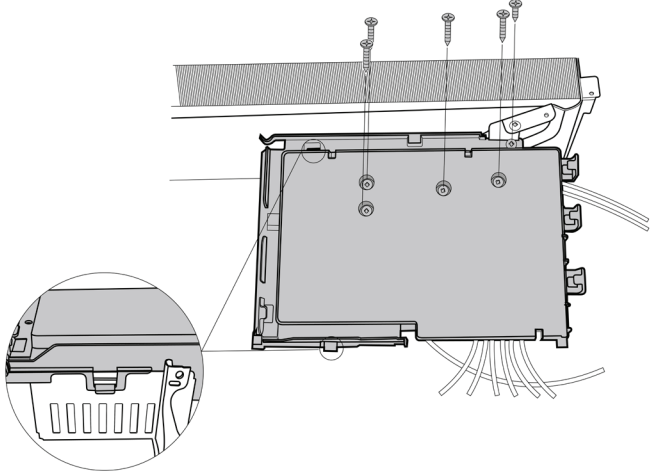
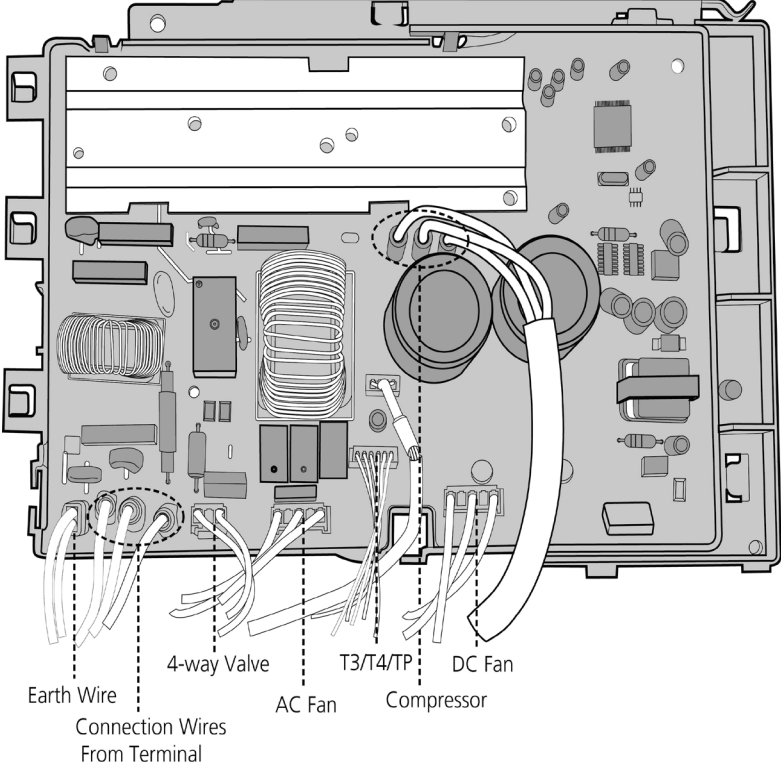
Procedure	Illustration
<p>1) Remove the screws and unfix the hooks, then open the electronic control box cover (5 screws and 2 hooks)(see CJ_ODU_PCB_006-1).</p>	 <p style="text-align: center;">CJ_ODU_PCB_006-1</p>
<p>2) Disconnect the connector for fan motor from the electronic control board (see CJ_ODU_PCB_006-2).</p> <p>3) Remove the connector for the compressor (see CJ_ODU_PCB_006-2).</p> <p>4) Pull out the two blue wires connected with the four way valve (see CJ_ODU_PCB_006-2).</p> <p>5) Pull out connectors of the condenser coil temp. sensor(T3),outdoor ambient temp. sensor(T4) and discharge temp. sensor(TP) (see CJ_ODU_PCB_006-2).</p> <p>6) Disconnect the electronic expansion valve wire (see Fig CJ_ODU_PCB_006-2).</p> <p>7) Remove the connector for the DR and reactor (see Fig CJ_ODU_PCB_006-2).</p> <p>8) Then remove the electronic control board.</p>	 <p style="text-align: center;">CJ_ODU_PCB_006-2</p>

Note: This section is for reference only. Actual unit appearance may vary.

6. PCB board 7

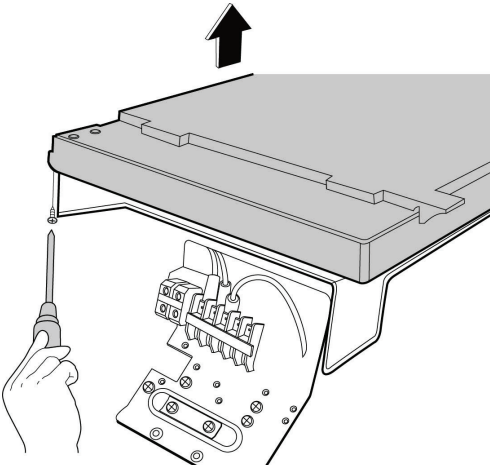
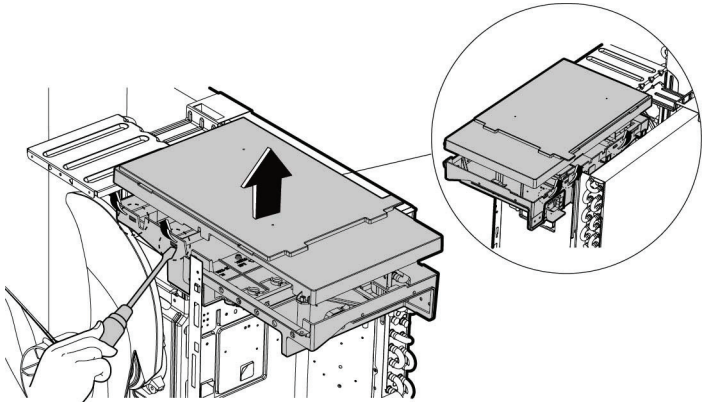
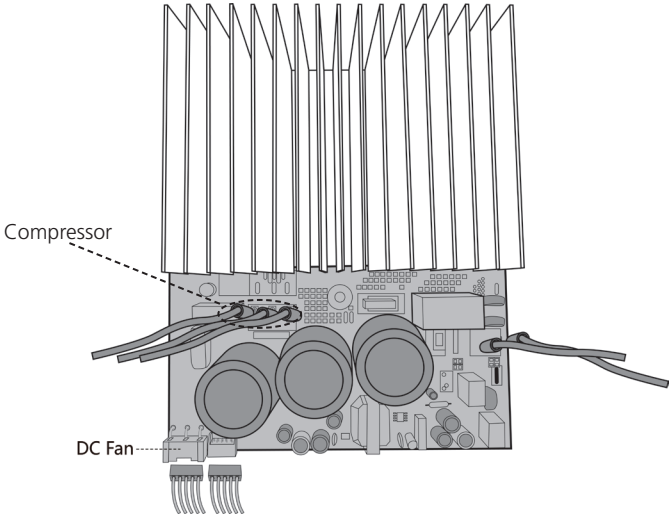
Procedure	Illustration
<p>1) Remove the screws of the top cover. (1 screws) (see CJ_ODU_PCB_007-1).</p>	 <p>The illustration shows a hand using a screwdriver to remove a screw from the top cover of the PCB board. An upward-pointing arrow indicates the direction to lift the cover. The PCB board is shown with various components and connectors.</p> <p data-bbox="889 741 1146 772">CJ_ODU_PCB_007-1</p>
<p>2) Unfix the hooks and then open the electronic control box cover (5 hooks) (see CJ_ODU_PCB_007-2).</p>	 <p>The illustration shows a hand using a screwdriver to unfix the hooks of the electronic control box cover. An upward-pointing arrow indicates the direction to lift the cover. A circular inset shows a close-up of the cover being lifted. The PCB board is shown with various components and connectors.</p> <p data-bbox="889 1213 1146 1245">CJ_ODU_PCB_007-2</p>
<p>3) Disconnect the connector for fan motor from the IPM board (see CJ_ODU_PCB_007-3).</p> <p>4) Remove the connector for the compressor (see CJ_ODU_PCB_007-3).</p>	 <p>The illustration shows the IPM board with various components and connectors. A hand is shown disconnecting the connector for the fan motor and the compressor. Labels 'Compressor' and 'DC Fan' are present. The PCB board is shown with various components and connectors.</p> <p data-bbox="889 1797 1146 1829">CJ_ODU_PCB_007-3</p>

Note: This section is for reference only. Actual unit appearance may vary.

Procedure	Illustration
<p>5) Pull out the wire connected with the terminal. (see CJ_ODU_PCB_007-4).</p> <p>6) Pull out connectors of the condenser coil temp. sensor(T3),outdoor ambient temp. sensor(T4) and discharge temp. sensor(TP) (see CJ_ODU_PCB_007-4).</p> <p>7) Disconnect the electronic expansion valve wire (see Fig CJ_ODU_PCB_007-4).</p> <p>8) Remove the connector for 4-way valve. (see Fig CJ_ODU_PCB_007-4).</p> <p>9) Remove the connector for the reactor (see Fig CJ_ODU_PCB_007-4).</p> <p>10)Then remove the electronic control box (see Fig CJ_ODU_PCB_007-4).</p>	<p style="text-align: center;">CJ_ODU_PCB_007-4</p>

Note: This section is for reference only. Actual unit appearance may vary.

7. PCB board 8

Procedure	Illustration
<ol style="list-style-type: none"> 1) Unfix the hooks and then open the electronic control box cover (4 hooks) (see CJ_ODU_PCB_008-1). 2) Disconnect the connector for outdoor DC fan from the electronic control board (see CJ_ODU_PCB_008-2). 3) Remove the connector for the compressor (see CJ_ODU_PCB_008-2). 4) Pull out the two blue wires connected with the four way valve (see CJ_ODU_PCB_008-2). 5) Pull out connectors of the condenser coil temp. sensor(T3), outdoor ambient temp. sensor(T4) and discharge temp. sensor(TP) (see CJ_ODU_PCB_008-2). 6) Disconnect the electronic expansion valve wire (see Fig CJ_ODU_PCB_008-2). 7) Disconnect the communication wire indoor PCB (see Fig CJ_ODU_PCB_008-2). 8) Disconnect the PFC inductor (see Fig CJ_ODU_PCB_008-2). 9) Then remove the electronic control box (see CJ_ODU_PCB_008-2). 	<p style="text-align: center;">CJ_ODU_PCB_008-1</p> <p style="text-align: center;">CJ_ODU_PCB_008-2</p> <p style="text-align: center;">Outdoor Unit Disassembly 26</p>

Note: This section is for reference only. Actual unit appearance may vary.

9. PCB board 9

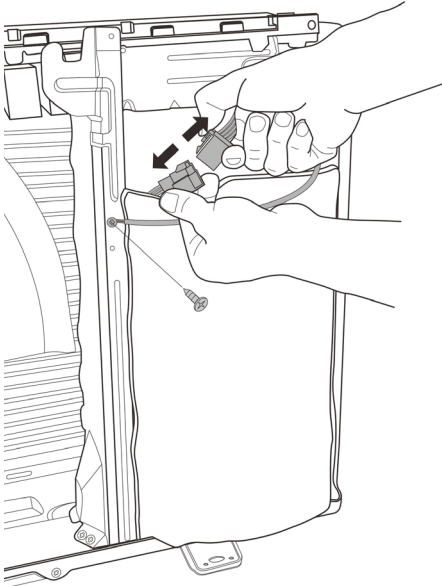
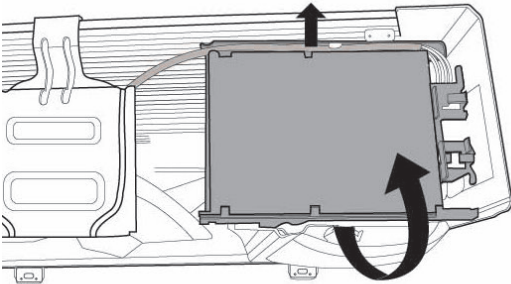
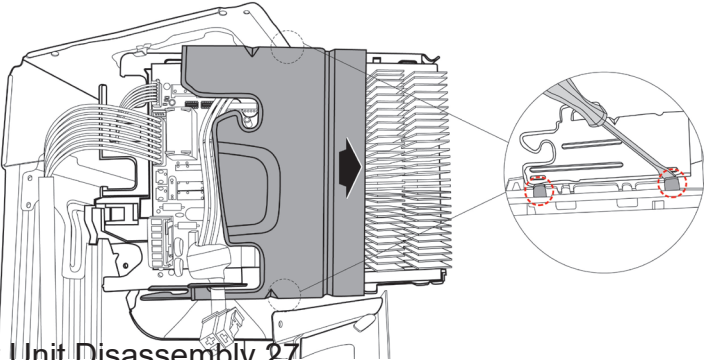
Procedure	Illustration
<p>1) Disconnect the connector for compressor and release the ground wire(1 screw). (see CJ_ODU_PCB_009-1).</p>	 <p style="text-align: center;">CJ_ODU_PCB_009-1</p>
<p>2) Pull out the wires from electrical supporting plate and turn over the electronic control assembly. (see CJ_ODU_PCB_009-2).</p>	 <p style="text-align: center;">CJ_ODU_PCB_009-2</p>
<p>3) Remove the electronic installing box subassembly (4 hooks) (see CJ_ODU_PCB_009-3).</p>	 <p style="text-align: center;">CJ_ODU_PCB_009-3</p>

Outdoor Unit Disassembly 27

Note: This section is for reference only. Actual unit appearance may vary.

Procedure

Illustration

4) Remove the fixing board (2 hooks)
(see CJ_ODU_PCB_009-4).

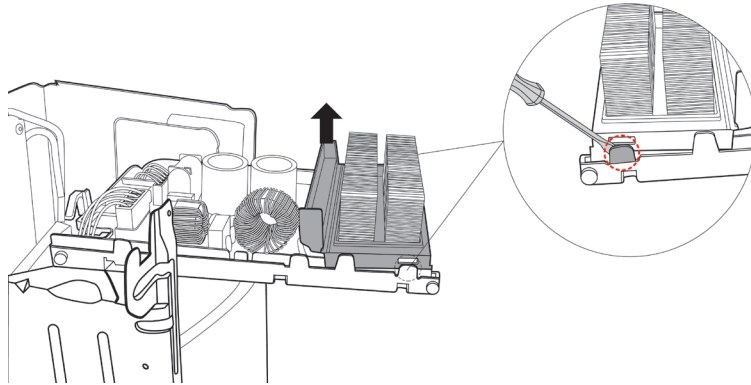

CJ_ODU_PCB_009-4

5) Disconnect the connectors from
the electronic control board (see
CJ_ODU_PCB_009-5).

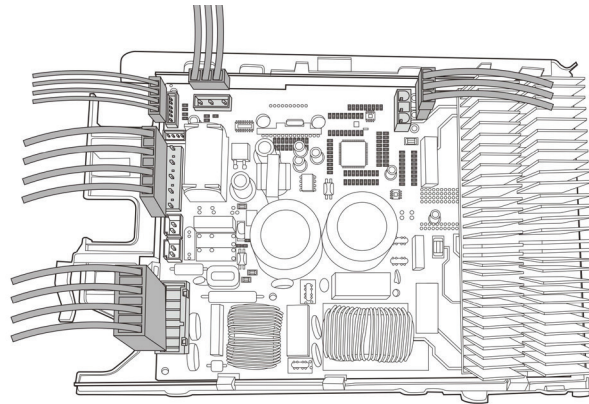

CJ_ODU_PCB_009-5

6) Then remove the electronic control
board (4 hooks).(see CJ_ODU_
PCB_009-6).

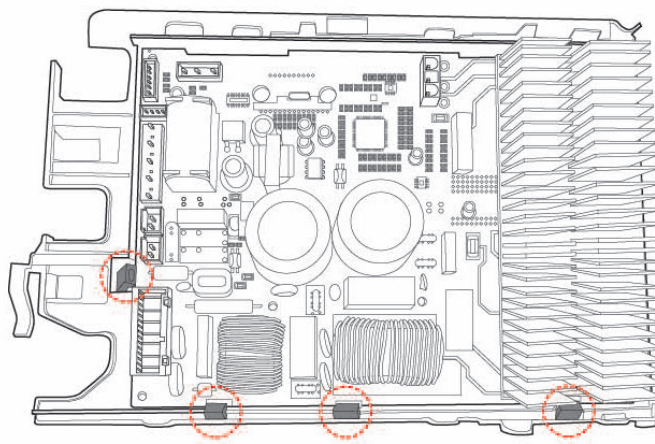

CJ_ODU_PCB_009-6

Note: This section is for reference only. Actual unit appearance may vary.

10. PCB board 10

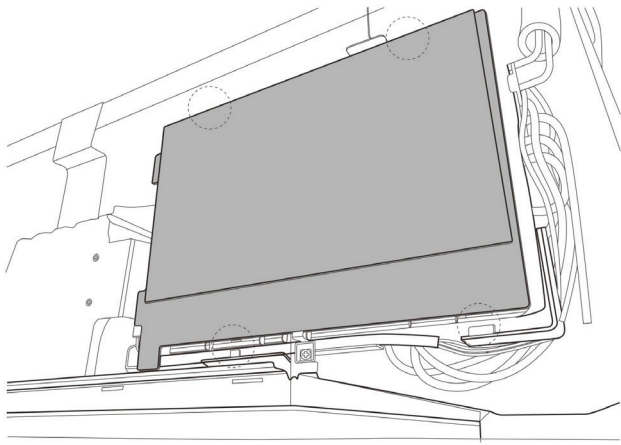
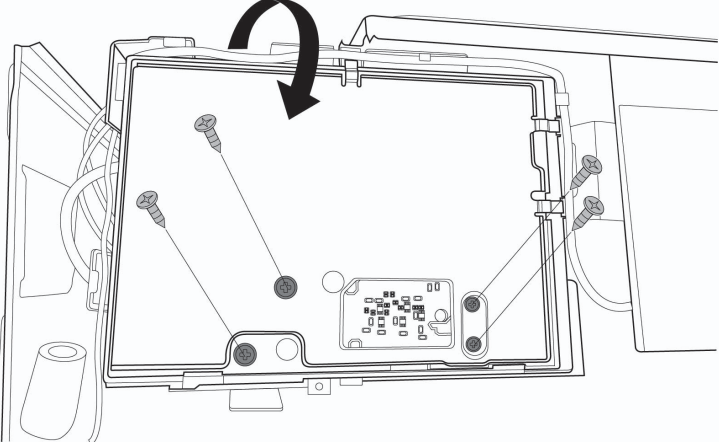
Procedure	Illustration
<p>1) Unfix the hooks and then open the electronic control box cover (4 hooks) (see CJ_ODU_PCB_010-1).</p>	 <p style="text-align: center;">CJ_ODU_PCB_010-1</p>
<p>2) Remove 4 screws on the electronic control board and then turn over the electronic control board (see CJ_ODU_PCB_010-2).</p>	 <p style="text-align: center;">CJ_ODU_PCB_010-2</p>

Note: This section is for reference only. Actual unit appearance may vary.

Procedure

- 3) Pull out the connectors (see CJ_ODU_PCB_010-3).
- 4) Remove the 9 screws and unfix the 3 hooks and then remove the electronic control board(see CJ_ODU_PCB_010-3).

Illustration

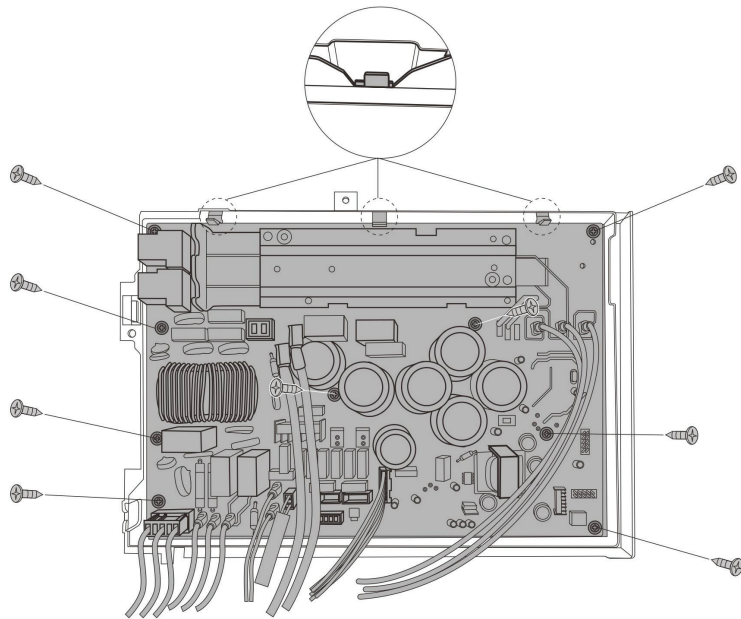

CJ_ODU_PCB_010-3

- 5) Remove two screws and then remove the electronic control box subassembly on partition board assembly. (see CJ_ODU_PCB_010-4).

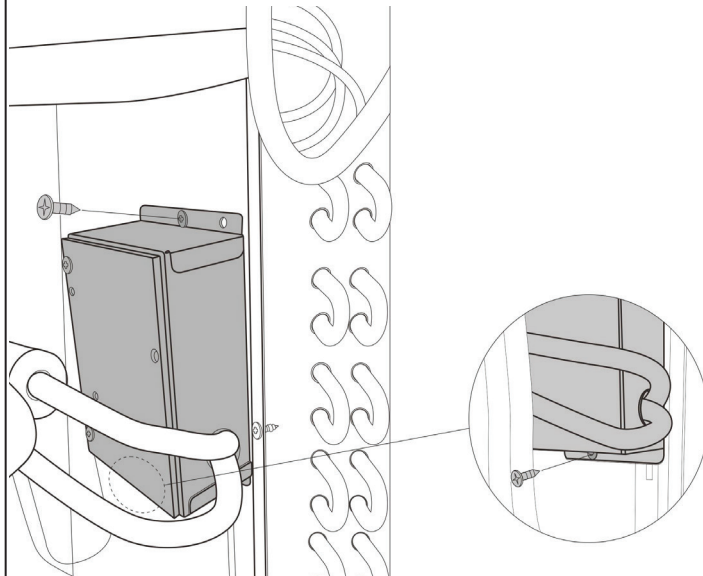

CJ_ODU_PCB_010-4

Note: This section is for reference only. Actual unit appearance may vary.

Procedure

- 6) Remove two screws and two connectors and then remove the inverter control board (see CJ_ODU_PCB_010-5).

Illustration

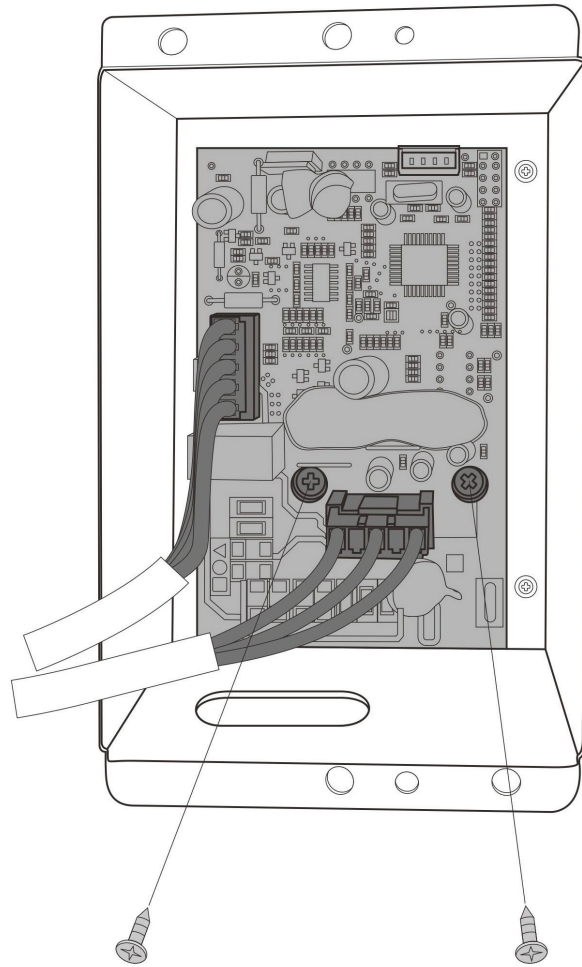

CJ_ODU_PCB_010-5

Note: This section is for reference only. Actual unit appearance may vary.

11. PCB board 11

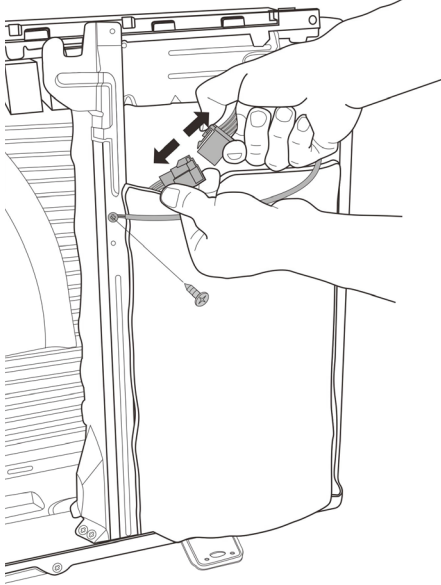
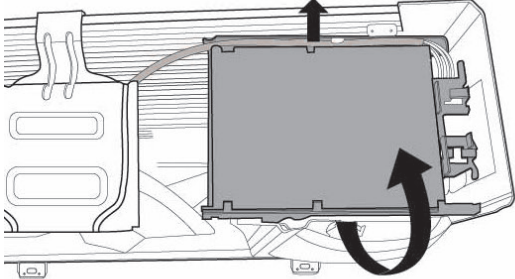
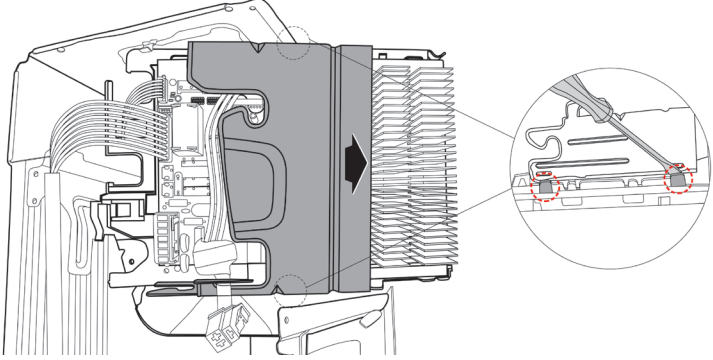
Procedure	Illustration
<p>1) Disconnect the connector for compressor and release the ground wire(1 screw). (see CJ_ODU_PCB_0011-1).</p>	 <p>The illustration shows a hand using a screwdriver to remove a screw from a ground wire terminal. Simultaneously, the hand is pulling a connector away from a compressor terminal. Arrows indicate the direction of movement for both actions.</p>
<p>2) Pull out the wires from electrical supporting plate and turn over the electronic control assembly. (see CJ_ODU_PCB_011-2).</p>	 <p>The illustration shows a hand pulling a bundle of wires out from an electrical supporting plate. Below this, the electronic control assembly is shown being turned over, with a curved arrow indicating the rotation.</p>
<p>3) Remove the electronic installing box subassembly (4 hooks) (see CJ_ODU_PCB_011-3).</p>	 <p>The illustration shows the electronic installing box subassembly being removed from the unit. A hook is used to lift the subassembly. An inset circular diagram provides a magnified view of the hook's interaction with the subassembly's hooks.</p>

Note: This section is for reference only. Actual unit appearance may vary.

Procedure

Illustration

4) Remove the fixing board (2 hooks)
(see CJ_ODU_PCB_011-4).

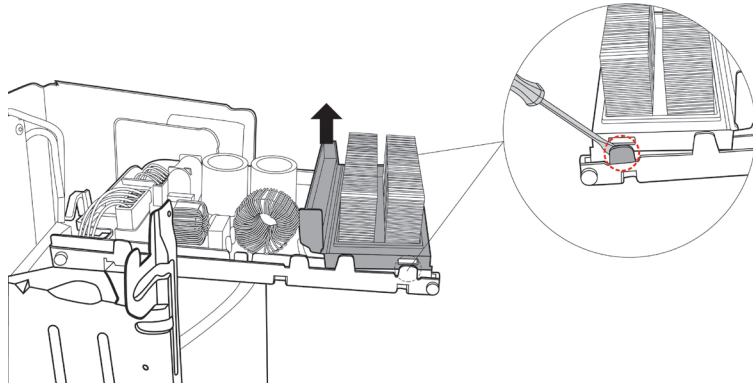

CJ_ODU_PCB_011-4

5) Disconnect the connectors from
the electronic control board (see
CJ_ODU_PCB_011-5).

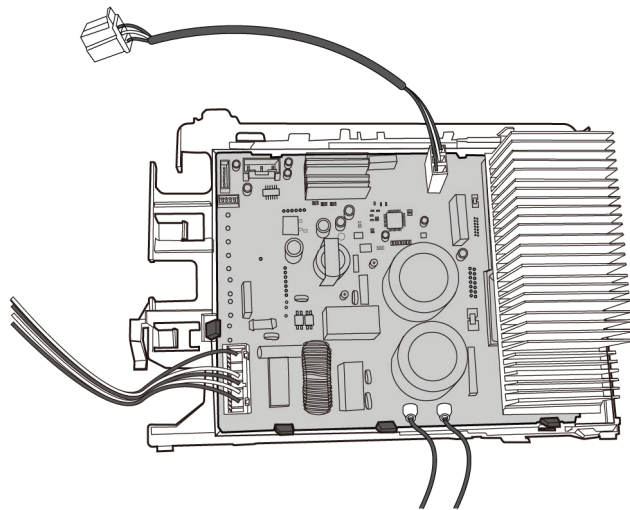

CJ_ODU_PCB_011-5

6) Then remove the electronic control
board (4 hooks).(see CJ_ODU_
PCB_011-6).

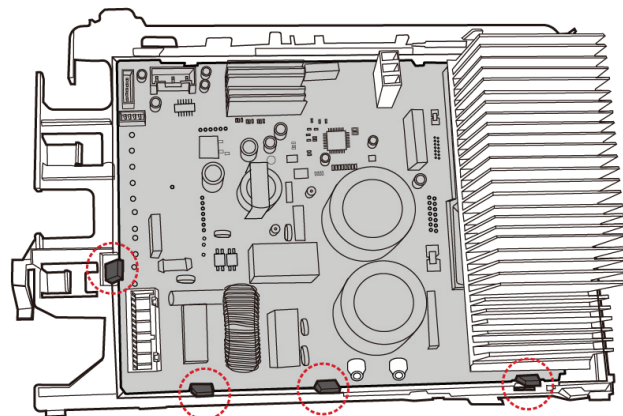

CJ_ODU_PCB_011-6

Note: This section is for reference only. Actual unit appearance may vary.

12. PCB board 12

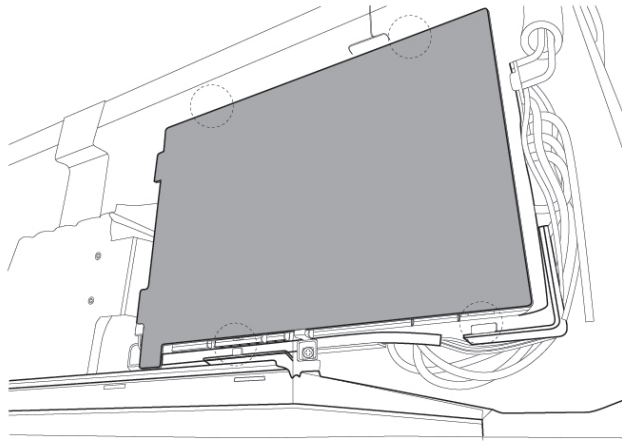
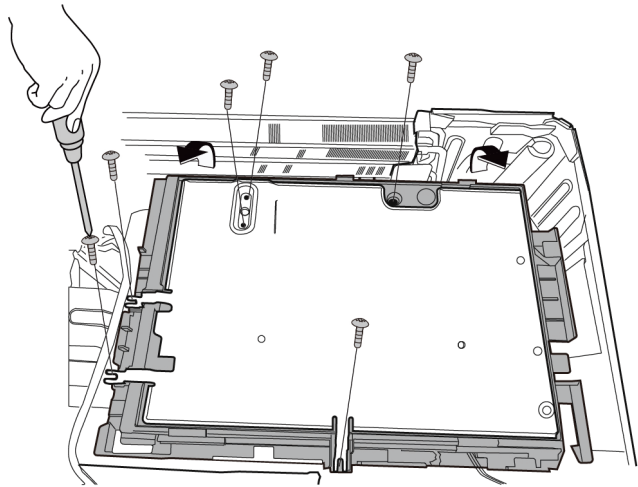
Procedure	Illustration
<p>1) Unfix the hooks and then open the electronic control box cover (4 hooks) (see CJ_ODU_PCB_012-1).</p>	 <p>The diagram shows a perspective view of the outdoor unit's electronic control box cover. The cover is a dark grey rectangular panel. Four dashed circles indicate the locations of hooks that hold the cover in place. The cover is shown being lifted away from the unit's chassis, with some internal wiring visible on the right side.</p> <p style="text-align: center;">CJ_ODU_PCB_012-1</p>
<p>2) Remove 6 screws on the electronic control board and then turn over the electronic control board (see CJ_ODU_PCB_012-2).</p>	 <p>The diagram shows a top-down view of the electronic control board. A hand is using a screwdriver to remove one of six screws that secure the board to the chassis. The board is a rectangular printed circuit board with various components. The screws are being removed from the top edge of the board. The chassis is shown in a perspective view, with the board being lifted slightly to show the underside.</p> <p style="text-align: center;">CJ_ODU_PCB_012-2</p>

Note: This section is for reference only. Actual unit appearance may vary.

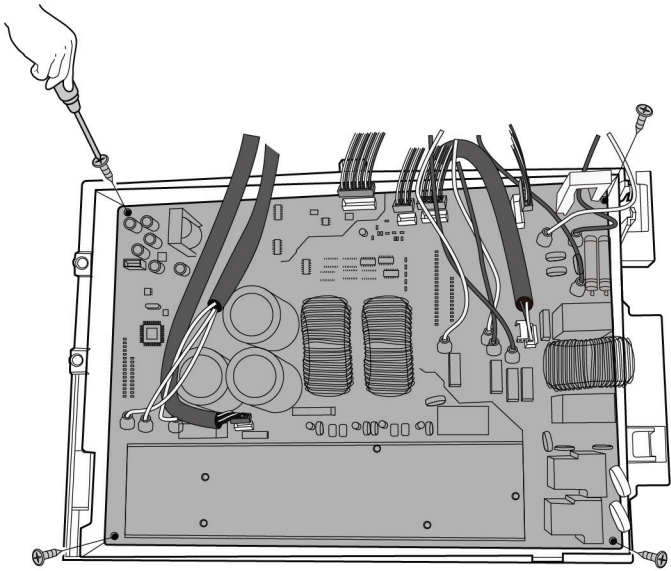
Procedure	Illustration
<p>3) Pull out the connectors (see CJ_ODU_PCB_012-3).</p> <p>4) Remove the 4 screws and then remove the electronic control board(see CJ_ODU_PCB_012-3).</p>	 <p data-bbox="899 869 1154 898">CJ_ODU_PCB_012-3</p>

Note: This section is for reference only. Actual unit appearance may vary.

13. PCB board 13

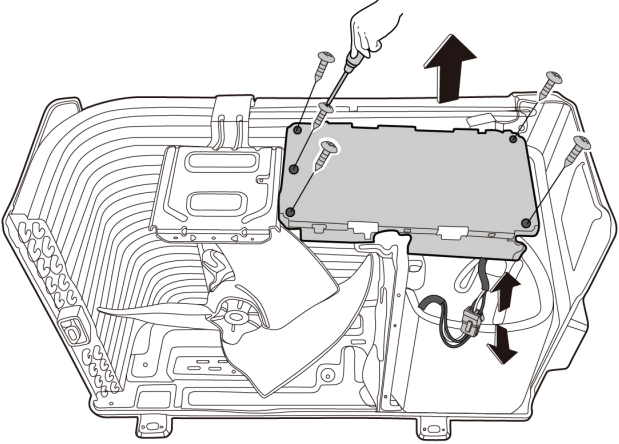
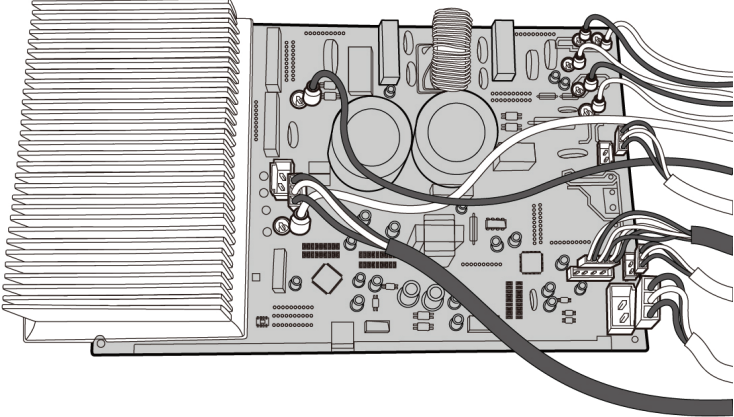
Procedure	Illustration
<p>1) Disconnect the connector for compressor. (see CJ_ODU_PCB_013-1).</p> <p>2) Remove the screws of cover of electronic control box(5 screws). (see CJ_ODU_PCB_009-1).</p> <p>3) Turn over the electronic control box subassembly</p> <p>4) Disconnect the connectors from the electronic control board (see CJ_ODU_PCB_013-2).</p> <p>5) Then remove the electronic control board.(see CJ_ODU_PCB_013-2).</p>	 <p style="text-align: center;">CJ_ODU_PCB_013-1</p>  <p style="text-align: center;">CJ_ODU_PCB_013-2</p>

Note: This section is for reference only. Actual unit appearance may vary.

3.3 Fan Assembly

Note: Remove the panel plate (refer to 3.1 Panel Plate) before disassembling fan.

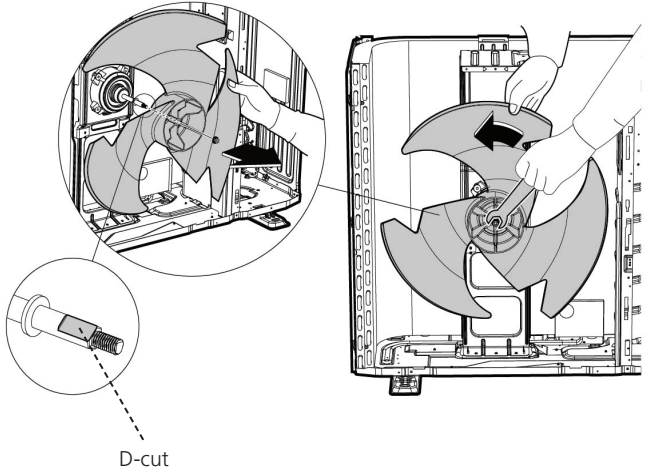
Procedure	Illustration
<p>1) Remove the nut securing the fan with a spanner (see CJ_ODU_FAN_001).</p> <p>2) Remove the fan.</p>	 <p data-bbox="906 890 1138 919">CJ_ODU_FAN_001</p>

Note: This section is for reference only. Actual unit appearance may vary.

3.4 Fan Motor

Note: Remove the panel plate and the connection of fan motor on PCB (refer to 3.1 Panel Plate and 3.2 Electrical parts) before disassembling fan motor.

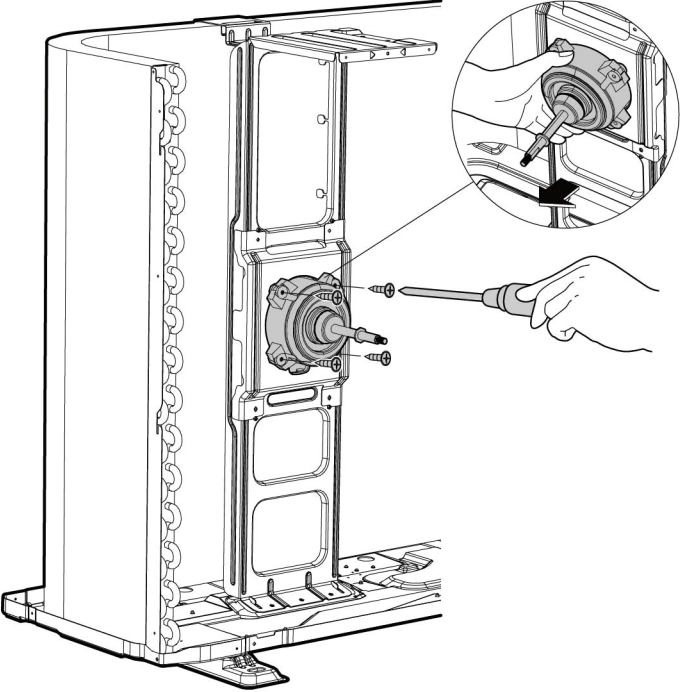
Procedure	Illustration
<p>3) Remove the fixing screws of the fan motor (4 screws) (see CJ_ODU_MOTOR_001).</p> <p>4) Remove the fan motor.</p>	 <p>CJ_ODU_MOTOR_001</p>

Note: This section is for reference only. Actual unit appearance may vary.

3.5 Sound blanket

Note: Remove the panel plate (refer to 3.1 Panel plate) before disassembling sound blanket.

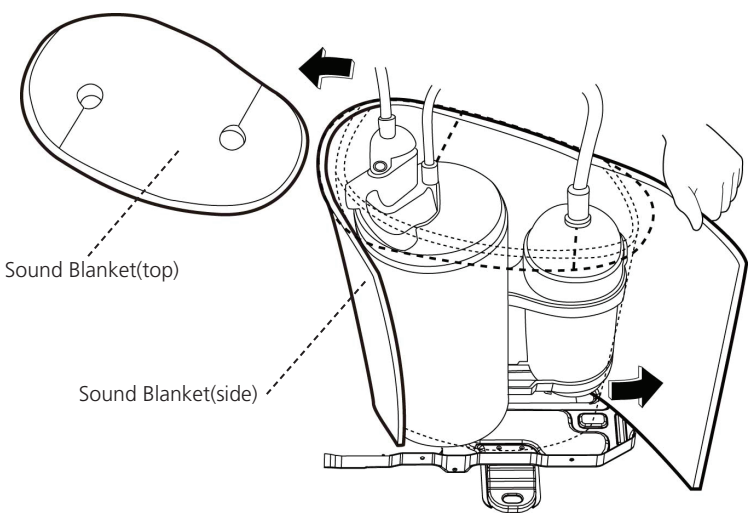
Procedure	Illustration
1) Remove the sound blanket (side and top) (see CJ_ODU_BLANKET_001).	 <p>The illustration shows a side view of an outdoor unit with two condenser coils. A hand is shown pulling a rectangular sound blanket away from the unit. Dashed lines indicate the blanket's position on the top and side of the unit. An arrow points to the top part of the blanket, labeled 'Sound Blanket(top)', and another arrow points to the side part, labeled 'Sound Blanket(side)'. The reference code 'CJ_ODU_BLANKET_001' is printed below the diagram.</p>

Note: This section is for reference only. Actual unit appearance may vary.

3.6 Four-way valve (for heat pump models)

⚠ WARNING: Evacuate the system and confirm that there is no refrigerant left in the system before removing the four-way valve and the compressor. (For R32 & R290, you should evacuate the system with the vacuum pump; flush the system with nitrogen; then repeat the two steps before heating up the brazed parts. The operations above should be implemented by professionals.)

Note: Remove the panel plate, connection of four-way valve on PCB (refer to 3.1 Panel plate and 3.2 Electrical parts) before disassembling sound blanket.

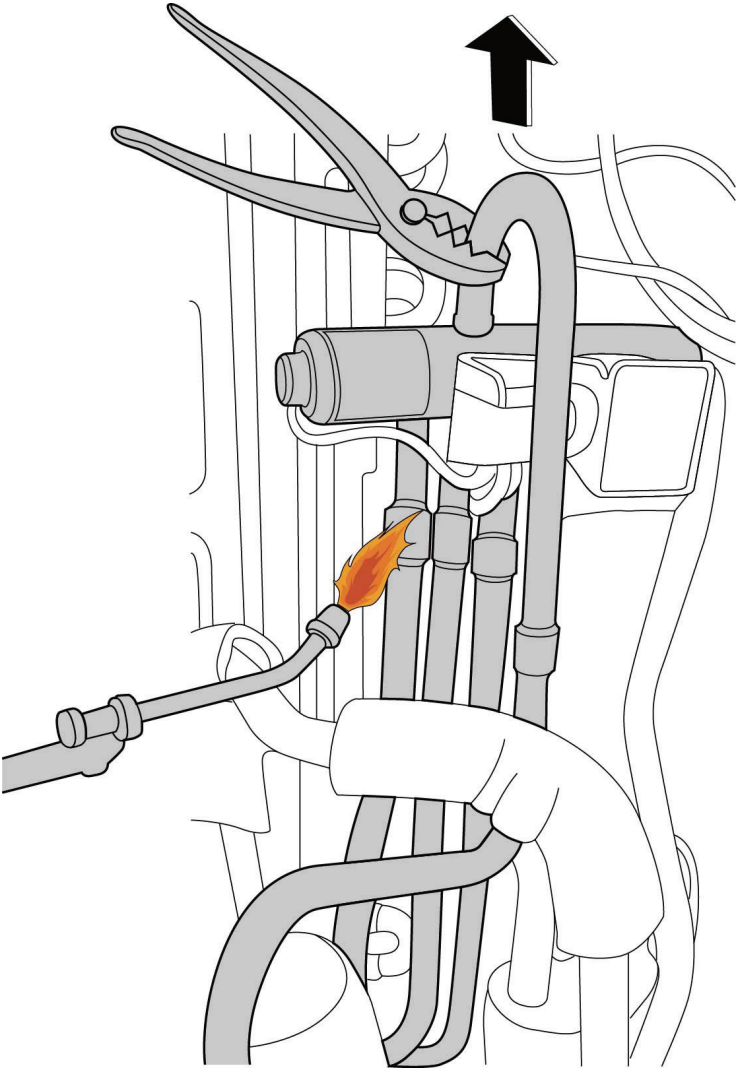
Procedure	Illustration
<p>1) Heat up the brazed parts and then detach the the four-way valve and the pipe (see CJ_ODU_VALVE_001).</p> <p>2) Remove the four-way valve assembly with pliers.</p>	 <p>CJ_ODU_VALVE_001</p>

Note: This section is for reference only. Actual unit appearance may vary.

3.7 Compressor

⚠ WARNING: Evacuate the system and confirm that there is no refrigerant left in the system before removing the four-way valve and the compressor. (For R32 & R290, you should evacuate the system with the vacuum pump; flush the system with nitrogen; then repeat the two steps before heating up the brazed parts. The operations above should be implemented by professionals.)

Note: Remove the panel plate, connection of compressor on PCB (refer to 3.1 Panel plate and 3.2 Electrical parts) before disassembling sound blanket.

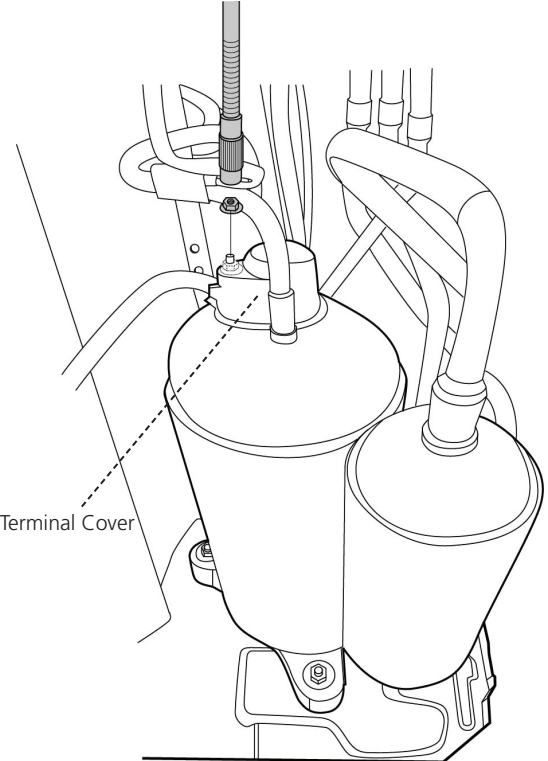
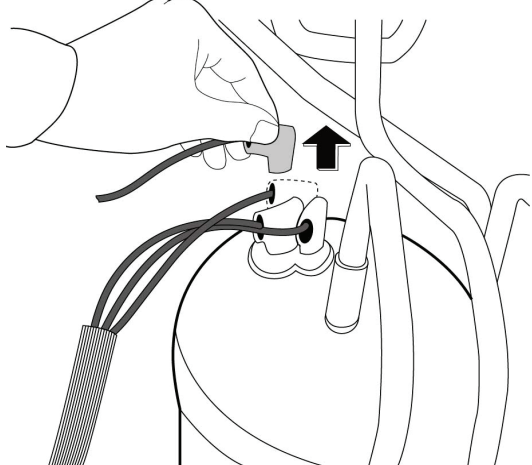
Procedure	Illustration
<p>1) Remove the flange nut of terminal cover and remove the terminal cover (see CJ_ODU_COMP_001).</p>	 <p>The diagram shows a top-down view of the compressor assembly. A terminal cover is being removed from the top of the compressor. A dashed line indicates the removal path. The label 'Terminal Cover' points to the cover being removed.</p> <p>CJ_ODU_COMP_001</p>
<p>2) Disconnect the connectors (see CJ_ODU_COMP_002).</p>	 <p>The diagram shows a close-up of the electrical connectors on the compressor. A hand is shown pulling a connector away from the terminal block. An upward-pointing arrow indicates the direction of removal.</p> <p>CJ_ODU_COMP_002</p>

Note: This section is for reference only. Actual unit appearance may vary.

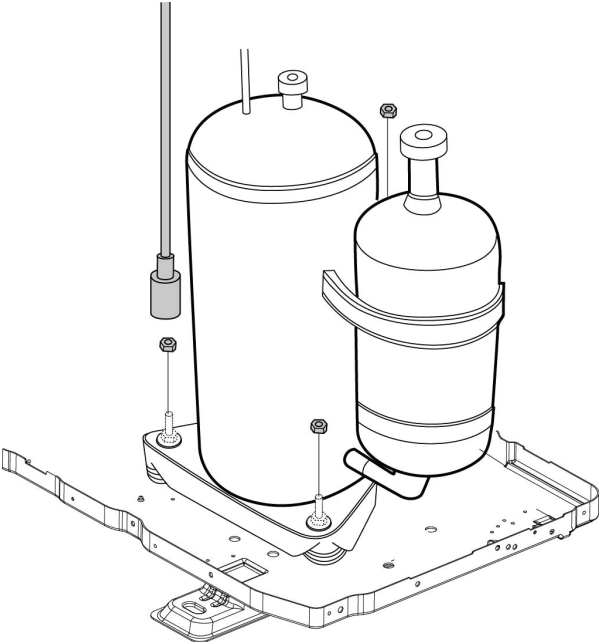
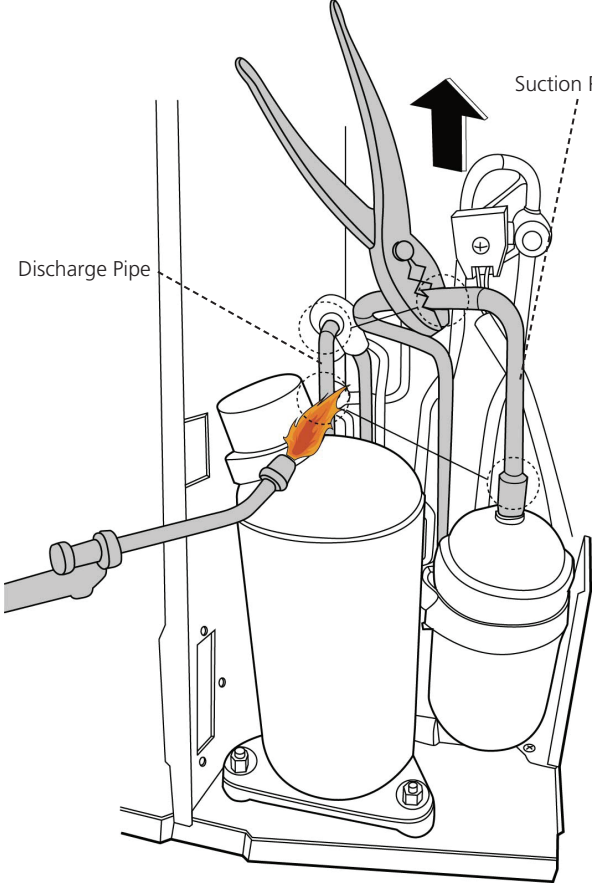
Procedure	Illustration
<p>3) Remove the hex nuts and washers securing the compressor, located on the bottom plate (see CJ_ODU_COMP_003).</p>	 <p style="text-align: center;">CJ_ODU_COMP_003</p>
<p>4) Heat up the brazed parts and then remove the the discharge pipe and the suction pipe (see CJ_ODU_COMP_004).</p> <p>5) Lift the compressor from the base pan assembly with pliers.</p>	 <p style="text-align: center;">CJ_ODU_COMP_004</p>

Note: This section is for reference only. Actual unit appearance may vary.

Troubleshooting

Contents

1.	Safety Caution	3
2.	General Troubleshooting	4
3.	Complain Record Form	6
4.	Information Inquiry	8
5.	Error Diagnosis and Troubleshooting Without Error Code.....	11
	5.1 Remote maintenance.....	11
	5.2 Field maintenance	12
6.	Quick Maintenance by Error Code.....	17
7.	Troubleshooting by Error Code.....	17
	TS01 EEPROM Parameter Error Diagnosis and Solution	
	TS02 Indoor and Outdoor Unit Communication Error Diagnosis and Solution	
	TS03 Zero-crossing Signal Detection Error Diagnosis and Solution	
	TS04 Fan Speed is Operating Outside of The Normal Range Diagnosis and Solution	
	TS05 Open Circuit or Short Circuit of Temperature Sensor Diagnosis and Solution	
	TS06 Refrigerant Leakage Detection Diagnosis and Solution	
	TS07 Indoor PCB/Display Board Communication Error Diagnosis and Solution	
	TS08 Current Overload Protection Diagnosis and Solution	

Contents

TS09 IPM Malfunction or IGBT Over-strong Current Protection Diagnosis and Solution

TS10 Over Voltage or Too Low Voltage Protection Diagnosis and Solution

TS11 Top temperature Protection of Compressor or High Temperature Protection of IPM Module or High Pressure Protection Diagnosis and Solution

TS12 Inverter Compressor Drive Error Diagnosis and Solution

TS13 Low Pressure Protection Diagnosis and Solution

TS14 Indoor units mode conflic Diagnosis and Solution

*TS33 Communication error between outdoor main chip and compressor driven chip
Diagnosis and Solution(for some manuals)

*TS34 AP mode is actived but there is no WIFI kit installed Diagnosis and Solution(for
some manuals)

8. Check Procedures

1. Safety Caution

! WARNING

Be sure to turn off all power supplies or disconnect all wires to avoid electric shock. While checking indoor/outdoor PCB, please equip oneself with antistatic gloves or wrist strap to avoid damage to the board.

! WARNING

Electricity remains in capacitors even when the power supply is off. Ensure the capacitors are fully discharged before troubleshooting.

Test the voltage between P and N on back of the main PCB with multimeter. If the voltage is lower than 36V, the capacitors are fully discharged.

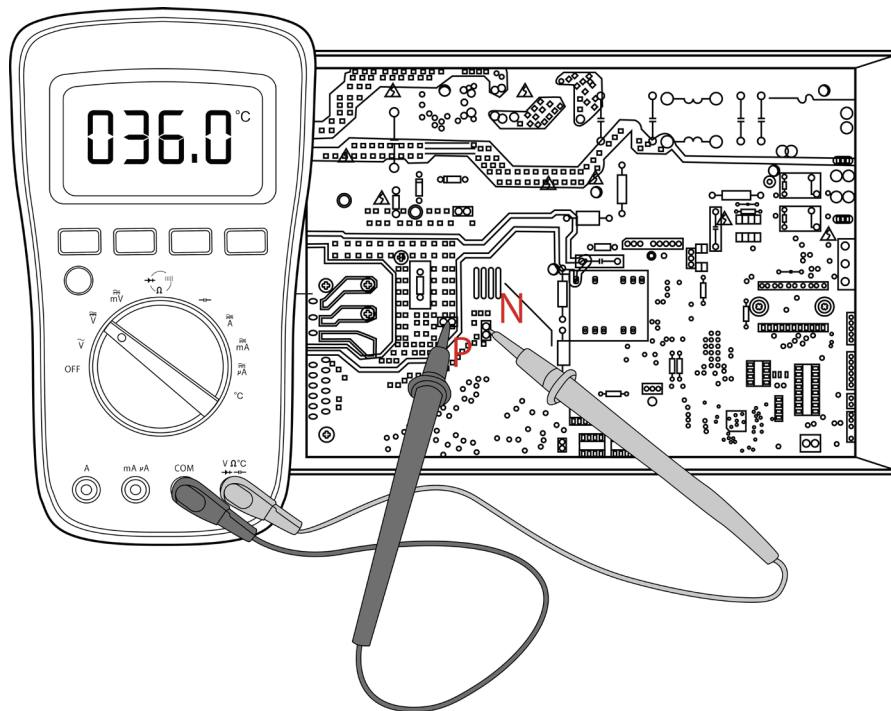

Note: This picture is for reference only. Actual appearance may vary.

2. General Troubleshooting

2.1 Error Display (Indoor Unit)

When the indoor unit encounters a recognized error on different models ,

1. the running LED with flash in a corresponding series, the timer LED may turn on or begin flashing;
2. an error code will be displayed;
3. both 1 and 2.

These error codes are described in the following tables:

Running Lamp	Timer Lamp	Display	Information	Solution
--	--	dF	Defrost	Normal Display, not error code
--	--	CL	Filter cleaning reminder(power on display for 15 seconds)	
--	--	CL	Active clean	
--	--	rF	Filter replacement reminder(power on display for 15 seconds)	
--	--	FP	Heating in room temperature under 8°C	
--	--	FC	Forced cooling	
--	--	RP	AP mode of WIFI connection	
--	--	CP	Remote switched off	
1 time	OFF	EH00/EH0A	Indoor unit EEPROM parameter error	TS01-IDU
2 times	OFF	EL01	Indoor/outdoor unit communication error	TS02-S-INV
3 times	OFF	EH02	Zero-crossing signal detection error	TS03
4 times	OFF	EH03	The indoor fan speed is operating outside of the normal range	TS04-S-IDU
5 times	OFF	EC51	Outdoor unit EEPROM parameter error	TS01-ODU
5 times	OFF	EC52	Condenser coil temperature sensor T3 is in open circuit or has short circuited	TS05-ODU
5 times	OFF	EC53	Outdoor room temperature sensor T4 is in open circuit or has short circuited	TS05-ODU
5 times	OFF	EC54	Compressor discharge temperature sensor TP is in open circuit or has short circuited	TS05-ODU
5 times	OFF	EC56	Evaporator coil outlet temperature sensor T2B is in open circuit or has short circuited(for free-match indoor units)	TS05-ODU
6 times	OFF	EH60	Indoor room temperature sensor T1 is in open circuit or has short circuited	TS05-IDU
6 times	OFF	EH61	Evaporator coil middle temperature sensor T2 is in open circuit or has short circuited	TS05-IDU
12 times	OFF	EC07	The outdoor fan speed is operating outside of the normal range	TS04-ODU
9 times	OFF	EH0b	Indoor PCB/Display board communication error	TS07
8 times	OFF	EL0C	Refrigerant leakage detection	TS06-INV
7 times	FLASH	PC00	IPM malfunction or IGBT over-strong current protection	TS09-S
2 times	FLASH	PC01	Over voltage or over low voltage protection	TS10-S

3 times	FLASH	PC02	Top temperature protection of compressor or High temperature protection of IPM module or High pressure protection	TS11-S-INV
5 times	FLASH	PC04	Inverter compressor drive error	TS12-S
1 time	FLASH	PC08	Current overload protection	TS08-S
6 times	FLASH	PC40	Communication error between outdoor main chip and compressor driven chip	TS33
7 times	FLASH	PC03	Low pressure protection	TS13-INV
1 times	ON	--	Indoor units mode conflict(match with multi outdoor unit)	TS14

For other errors:

The display board may show a garbled code or a code undefined by the service manual. Ensure that this code is not a temperature reading.

Troubleshooting:

Test the unit using the remote control. If the unit does not respond to the remote, the indoor PCB requires replacement. If the unit responds, the display board requires replacement.

88 flash frequency:

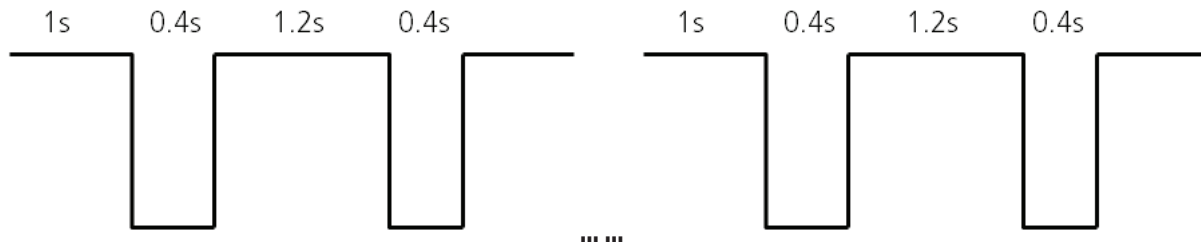

3. Complain Record Form

Complain Record Form

Request No.:

Date:

Installation Date:

Service Date:

Customer Information			
Name		Telephone No.	
Home Address			
Email			
Product Information			
Indoor Unit Model		Outdoor Unit Model	
Serial No. of indoor unit			
Serial No. of outdoor unit			
Working Mode	<input type="checkbox"/> Cooling <input type="checkbox"/> Heating <input type="checkbox"/> Fan only <input type="checkbox"/> Dry		
Setting temperature	_____°C / °F	Fan speed	<input type="checkbox"/> Turbo <input type="checkbox"/> High <input type="checkbox"/> Medium <input type="checkbox"/> Low <input type="checkbox"/> Auto
Temperature of air inlet	_____°C / °F	Temperature of air outlet	_____°C / °F
Installation / Condition Information			
Indoor temperature	_____°C / °F	Indoor humidity	_____ %RH
Outdoor temperature	_____°C / °F	Outdoor humidity	_____ %RH
Length of Connecting pipe	—	Pipe diameter	Gas pipe: Liquid pipe:
Length of Wiring		wire diameter	
System Running Pressure	_____MPa or _____Bar or _____PSI		
Room size (L*W*H)			
Photo of Installation of Indoor unit (Photo #1)		Photo of Installation of Outdoor unit (Photo #2)	
Failure Description			
Error Code of Indoor unit		Code of Outdoor PCB	
Unit does not start			
Remote control does not work			
Indoor display shows nothing			
No cooling or heating at all			
Less cooling or heating			
Unit starts but stops shortly			
High noise			
High vibration			

Parameter Checking information by Remote controller			
Displaying code	Displaying code meaning	Display value	Display value meaning
T1	Room temperature		
T2	Indoor coil temperature		
T3	Outdoor coil temperature		
T4	Ambient temperature		
TP	Discharge temperature		
FT	Targeted Frequency		
Fr	Actual Frequency		
dL	Compressor current		
Uo	Outdoor AC voltage		
Sn	Indoor capacity test	/	N/A
--	Reserve	/	N/A
Pr	Outdoor fan speed		
Lr	EXV opening steps		
ir	Indoor fan speed		
HU	Indoor humidity		
TT	Adjusted setting temperature		
DT	Reserve	/	N/A
iF	Reserve	/	N/A
nA	Reserve	/	N/A
oT	GA algorithm frequency		

Approval from Manufacturer	
<input type="checkbox"/> Approved	
<input type="checkbox"/> More Proof needed	
<input type="checkbox"/> Rejected	

4. Information Inquiry

- To enter engineer mode, in power-on or standby mode, and in non-locked state, press the key combination “ON/OFF + Air Speed” for 7s:
- After entering the engineer mode, the remote control will display icons of “Auto, Cool, Dry, Heat”, and the Battery icon; at the same time, it will also display the numeric code of the current engineer mode (for the initial engineer mode, the numeric code displayed is 0), and all other icons are inactive.
- In engineer mode, the value of the current numeric code can be adjusted circularly through the Up/Down key, with the setting range of 0 to 30.

Code	Query Content	Additional Notes
0	Error code	Refer to next list of error code
1	Room temperature	T1 temperature
2	Indoor coil temperature	T2 temperature
3	Outdoor coil temperature	T3 temperature
4	Ambient temperature	T4 temperature
5	Discharge temperature	TP temperature
6	Compressor Target Frequency FT	Targeted Frequency
7	Compressor Running Frequency Fr	Actual Frequency
8	Unit Current dL	N/A
9	Outdoor AC Voltage Uo	N/A
10	Current indoor capacity test state Sn	N/A
11	Reserve	
12	Set Speed Pr of the outdoor fan	Outdoor fan speed=value*8
13	Opening Lr of EEV	EXV opening angle-value*8
14	Actual Running Speed ir of the indoor fan	Indoor fan speed=value*8
15	Indoor Humidity Hu	N/A
16	Set Temperature TT after compensation	N/A
17	Reserve	N/A
18	Reserve	N/A
19	/	N/A
20	Indoor Target Frequency oT	N/A
21	Reserve	
22		
23		
24		
25		
26		
27		
28		
29		
30		

Exit of engineer mode:

1)In engineer mode, press the key combination of “On/Off + Air speed” for 2s;

2)The engineer mode will be exited if there are no valid key operations for continuous 60s.

Error code

Display	Error Information
EH 00/EH 0A	Indoor unit EEPROM parameter error
EL 01	Indoor / outdoor unit communication error
EH 02	Zero-crossing signal detection error
EH 30	Over low voltage protection of indoor external fan
EH 31	Over voltage protection of indoor external fan
EH 03	The indoor fan speed is operating outside of the normal range
EC 51	Outdoor unit EEPROM parameter error
EC 52	Condenser coil temperature sensor T3 is in open circuit or has short circuited
EC 53	Outdoor room temperature sensor T4 is in open circuit or has short circuited
EC 54	Compressor discharge temperature sensor TP is in open circuit or has short circuited
EC 56	Evaporator coil outlet temperature sensor T2B is in open circuit or has short circuited
EH 60	Indoor room temperature sensor T1 is in open circuit or has short circuited
EH 61	Evaporator coil temperature sensor T2 is in open circuit or has short circuited
EC 07	The outdoor fan speed is operating outside of the normal range(
EH 0b	Indoor PCB/Display board communication error
EL 0C	Refrigerant leak detected
PC 00	IPM malfunction or IGBT over-strong current protection
PC 10	Over low voltage protection
PC 11	Over voltage protection
PC 12	DC voltage protection
PC 02	Compressor top high temperature protection (OLP)
PC 03	Pressure protection
PC 40	Communication error between outdoor main chip and compressor driven chip
PC 41	Current Input detection protection
PC 42	Compressor start error
PC 43	Lack of phase (3 phase) protection
PC 44	No speed protection
PC 45	341PWM error
PC 46	Compressor speed malfunction
PC 49	Compressor over current protection
--	Indoor units mode conflict(match with multi outdoor unit)
PC 0A	Condenser high temperature protection

PC 06	Compressor discharge temperature protection
PC 08	Outdoor current protection
PH 09	Anti-cold air in heating mode
PC 0F	PFC module malfunction
PC 0L	Outdoor ambient temperature too low
PH 90	Evaporator coil temperature over high protection
PH 91	Evaporator coil temperature over low Protection
LC 05	Frequency limit caused by voltage
LC 03	Frequency limit caused by current
LC 02	Frequency limit caused by TP
LC 01	Frequency limit caused by T3
LH 00	Frequency limit caused by T2
LC 06	Frequency limit caused by PFC
LH 07	Frequency limit caused by remote controller
NR	no malfunction or protection

5. Error Diagnosis and Troubleshooting Without Error Code

WARNING

Be sure to turn off unit before any maintenance to prevent damage or injury.

5.1 Remote maintenance

SUGGESTION: When troubles occur, please check the following points with customers before field maintenance.

No.	Problem	Solution
1	Unit will not start	13-14
2	The power switch is on but fans will not start	13-14
3	The temperature on the display board cannot be set	13-14
4	Unit is on but the wind is not cold(hot)	13-14
5	Unit runs, but shortly stops	13-14
6	The unit starts up and stops frequently	13-14
7	Unit runs continuously but insufficient cooling(heating)	13-14
8	Cool can not change to heat	13-14
9	Unit is noisy	13-14

5.2 Field maintenance

	Problem	Solution
1	Unit will not start	15-16
2	Compressor will not start but fans run	15-16
3	Compressor and condenser (outdoor) fan will not start	15-16
4	Evaporator (indoor) fan will not start	15-16
5	Condenser (Outdoor) fan will not start	15-16
6	Unit runs, but shortly stops	15-16
7	Compressor short-cycles due to overload	15-16
8	High discharge pressure	15-16
9	Low discharge pressure	15-16
10	High suction pressure	15-16
11	Low suction pressure	15-16
12	Unit runs continuously but insufficient cooling	15-16
13	Too cool	15-16
14	Compressor is noisy	15-16
15	Horizontal louver can not revolve	15-16

1.Remote Maintenance	Electrical Circuit				Refrigerant Circuit													
Possible causes of trouble	Power failure																	
	The main power tripped																	
	Loose connections																	
	Faulty transformer																	
	The voltage is too high or too low																	
	The remote control is powered off																	
	Broken remote control																	
	Dirty air filter																	
	Dirty condenser fins																	
	The setting temperature is higher /lower than the room's(cooling/heating)																	
	The ambient temperature is too high/low when the mode is cooling/heating																	
	Fan mode																	
SILENCE function is activated(optional function)																		
Frosting and defrosting frequently																		
Unit will not start	☆	☆	☆	☆														
The power switch is on but fans will not start			☆	☆	☆													
The temperature on the display board cannot be set						☆	☆											
Unit is on but the wind is not cold(hot)										☆	☆	☆						
Unit runs, but shortly stops					☆					☆	☆							
The unit starts up and stops frequently					☆					☆	☆				☆			
Unit runs continuously but insufficient cooling(heating)								☆	☆	☆	☆		☆					
Cool can not change to heat																		
Unit is noisy																		
Test method / remedy	Test voltage																	
	Close the power switch																	
	Inspect connections - tighten																	
	Change the transformer																	
	Test voltage																	
	Replace the battery of the remote control																	
	Replace the remote control																	
	Clean or replace																	
	Clean																	
	Adjust the setting temperature																	
	Turn the AC later																	
	Adjust to cool mode																	
Turn off SILENCE function.																		
Turn the AC later																		

1.Remote Maintenance	Others					
Possible causes of trouble	Heavy load condition					
	Loosen hold down bolts and / or screws					
	Bad airproof					
	The air inlet or outlet of either unit is blocked					
	Interference from cell phone towers and remote boosters					
	Shipping plates remain attached					
Unit will not start						
The power switch is on but fans will not start					☆	
The temperature on the display board cannot be set						
Unit is on but the wind is not cold(hot)						
Unit runs, but shortly stops						
The unit starts up and stops frequently				☆		
Unit runs continuously but insufficient cooling(heating)	☆		☆	☆		
Cool can not change to heat						
Unit is noisy		☆				☆
Test method / remedy	Check heat load					
	Tighten bolts or screws					
	Close all the windows and doors					
	Remove the obstacles					
	Reconnect the power or press ON/OFF button on remote control to restart operation					
	Remove them					

2.Field Maintenance	Refrigerant Circuit													Others									
Possible causes of trouble	Compressor stuck	Shortage of refrigerant	Restricted liquid line	Dirty air filter	Dirty evaporator coil	Insufficient air through evaporator coil	Overcharge of refrigerant	Dirty or partially blocked condenser	Air or incompressible gas in refrigerant cycle	Short cycling of condensing air	High temperature condensing medium	Insufficient condensing medium	Broken compressor internal parts	Inefficient compressor	Expansion valve obstructed	Expansion valve or capillary tube closed completely	Leaking power element on expansion valve	Poor installation of feeler bulb	Heavy load condition	Loosen hold down bolts and / or screws	Shipping plates remain attached	Poor choices of capacity	Contact of piping with other piping or external plate
Unit will not start																							
Compressor will not start but fans run	☆																						
Compressor and condenser (outdoor) fan will not start																							
Evaporator (indoor) fan will not start																							
Condenser (Outdoor) fan will not start																							
Unit runs, but shortly stops	☆	☆					☆	☆								☆	☆						
Compressor short-cycles due to overload	☆						☆	☆															
High discharge pressure							☆	☆	☆	☆	☆												
Low discharge pressure		☆												☆									
High suction pressure							☆							☆				☆	☆				
Low suction pressure		☆	☆	☆	☆	☆									☆	☆	☆						
Unit runs continuously but insufficient cooling		☆	☆	☆	☆	☆		☆	☆	☆				☆					☆			☆	
Too cool																							
Compressor is noisy							☆						☆							☆	☆		☆
Horizontal louver can not revolve																							
Test method / remedy	Replace the compressor	Leak test	Replace restricted part	Clean or replace	Clean coil	Check fan	Change charged refrigerant volume	Clean condenser or remove obstacle	Purge, evacuate and recharge	Remove obstruction to air flow	Remove obstruction in air or water flow	Remove obstruction in air or water flow	Replace compressor	Test compressor efficiency	Replace valve	Replace valve	Replace valve	Fix feeler bulb	Check heat load	Tighten bolts or screws	Remove them	Choose AC of larger capacity or add the number of AC	Rectify piping so as not to contact each other or with external plate

2.Field Maintenance	Electrical Circuit														
Possible causes of trouble	Power failure	Blown fuse or varistor	Loose connections	Shorted or broken wires	Safety device opens	Faulty thermostat / room temperature sensor	Wrong setting place of temperature sensor	Faulty transformer	Shorted or open capacitor	Faulty magnetic contactor for compressor	Faulty magnetic contactor for fan	Low voltage	Faulty stepping motor	Shorted or grounded compressor	Shorted or grounded fan motor
Unit will not start	☆	☆	☆	☆	☆			☆							
Compressor will not start but fans run				☆	☆				☆	☆				☆	
Compressor and condenser (outdoor) fan will not start				☆	☆					☆					
Evaporator (indoor) fan will not start				☆					☆		☆				☆
Condenser (Outdoor) fan will not start				☆	☆				☆		☆				☆
Unit runs, but shortly stops										☆		☆			
Compressor short-cycles due to overload										☆		☆			
High discharge pressure															
Low discharge pressure															
High suction pressure															
Low suction pressure															
Unit runs continuously but insufficient cooling															
Too cool						☆	☆								
Compressor is noisy															
Horizontal louver can not revolve			☆	☆									☆		
Test method / remedy	Test voltage	Inspect fuse type & size	Inspect connections - tighten	Test circuits with tester	Test continuity of safety device	Test continuity of thermostat / sensor & wiring	Place the temperature sensor at the central of the air inlet grille	Check control circuit with tester	Check capacitor with tester	Test continuity of coil & contacts	Test continuity of coil & contacts	Test voltage	Replace the stepping motor	Check resistance with multimeter	Check resistance with multimeter

6. Quick Maintenance by Error Code

If you do not have the time to test which specific parts are faulty, you can directly change the required parts according to the error code. You can find the parts to replace by error code in the following table.

Part requiring replacement	Error Code									
	EH 00/ EH 0R	EL 01	EH 02	EH 03	EH 60	EH 61	EH 0b	EL 0C	EC 56	PC 08
Indoor PCB	✓	✓	✓	✓	✓	✓	✓	✓	x	x
Outdoor PCB	x	✓	x	x	x	x	x	x	✓	✓
Display board	x	x	x	x	x	x	✓	x	x	x
Indoor fan motor	x	x	x	✓	x	x	x	x	x	x
T1 sensor	x	x	x	x	✓	x	x	x	x	x
T2 Sensor	x	x	x	x	x	✓	x	✓	x	x
T2B Sensor	x	x	x	x	x	x	x	x	✓	x
Reactor	x	✓	x	x	x	x	x	x	x	x
Compressor	x	x	x	x	x	x	x	x	x	✓
Additional refrigerant	x	x	x	x	x	x	x	✓	x	x

Part requiring replacement	EC 53	EC 52	EC 54	EC 51	EC 07	PC 00	PC 01	PC 02	PC 03	PC 04
Outdoor PCB	✓	✓	✓	✓	✓	✓	✓	✓	✓	✓
Indoor fan motor	x	x	x	x	x	x	x	x	x	x
Outdoor fan motor	x	x	x	x	✓	✓	x	✓	x	✓
T3 Sensor	x	✓	x	x	x	x	x	x	x	x
T4 Sensor	✓	x	x	x	x	x	x	x	x	x
TP Sensor	x	x	✓	x	x	x	x	x	x	x
Reactor	x	x	x	x	x	x	✓	x	x	x
Compressor	x	x	x	x	x	✓	x	x	x	✓
IPM module board	x	x	x	x	x	✓	✓	✓	x	✓
High pressure protector	x	x	x	x	x	x	x	✓	x	x
Low pressure protector	x	x	x	x	x	x	x	x	✓	x
Additional refrigerant	x	x	x	x	x	x	x	x	✓	x

Note: For certain models, outdoor PCB could not be removed separately. In this case, the outdoor electric control box should be replaced as a whole.

7. Troubleshooting by Error Code

TS01-IDU: Indoor EEPROM parameter error diagnosis and solution

Description: Indoor PCB main chip does not receive feedback from EEPROM chip.

Recommended parts to prepare:

- Indoor PCB

Troubleshooting and repair:

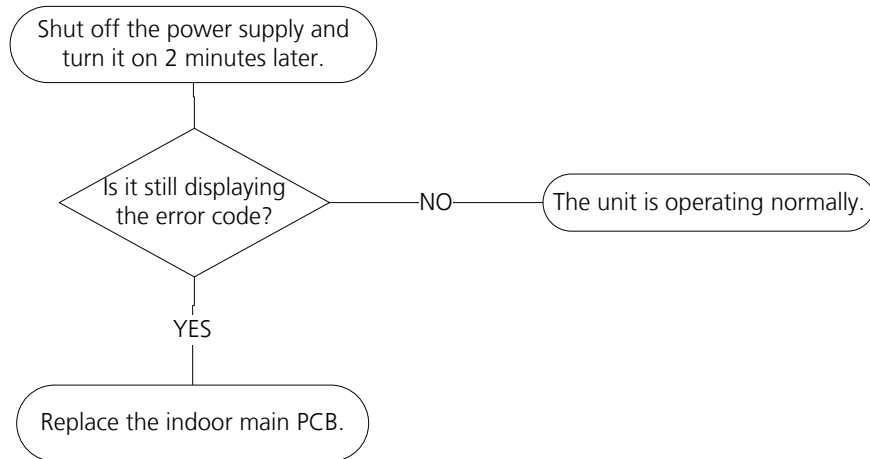

Remarks:

EEPROM: A read-only memory whose contents can be erased and reprogrammed using a pulsed voltage.

The location of the EEPROM chip on the indoor PCB is shown in the following image:

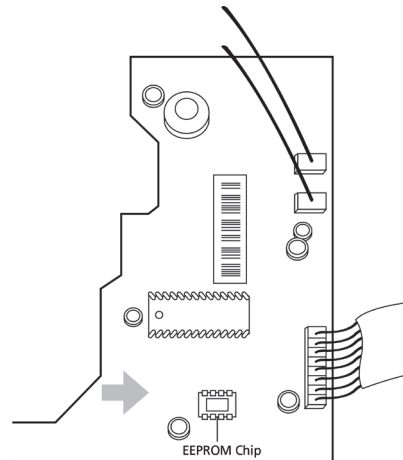

Note: This pictures are only for reference, actual appearance may vary.

TS01-ODU: Outdoor EEPROM parameter error or Compressor driven chip EEPROM parameter error diagnosis and solution

Description: Outdoor PCB main chip does not receive feedback from EEPROM chip or compressor driven chip.

Recommended parts to prepare:

- Outdoor PCB

Troubleshooting and repair:

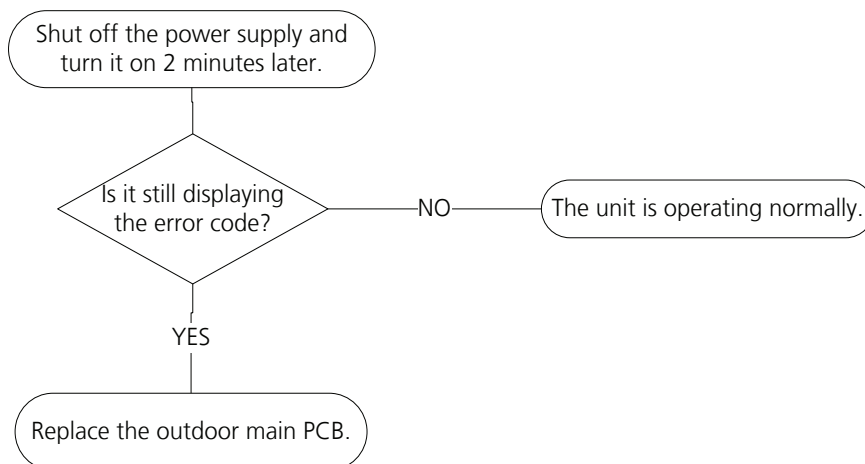

Remarks:

EEPROM: A read-only memory whose contents can be erased and reprogrammed using a pulsed voltage.

The location of the EEPROM chip on the outdoor PCB is shown in the following image:

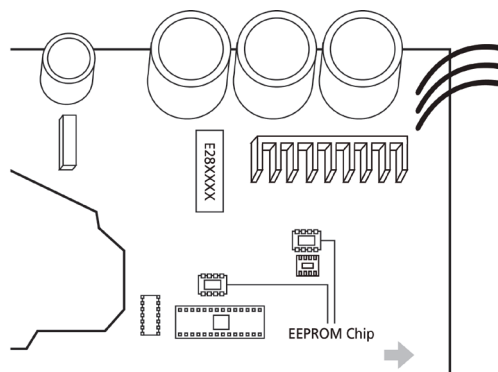

Note: For certain models, outdoor PCB could not be removed separately. In this case, the outdoor electric control box should be replaced as a whole. This pictures are only for reference, actual appearance may vary.

TS02-S-INV: Indoor and outdoor unit communication error diagnosis and solution

Description: Indoor unit can not communicate with outdoor unit

Recommended parts to prepare:

- Indoor PCB
- Outdoor PCB
- Short-circuited component

Troubleshooting and repair:

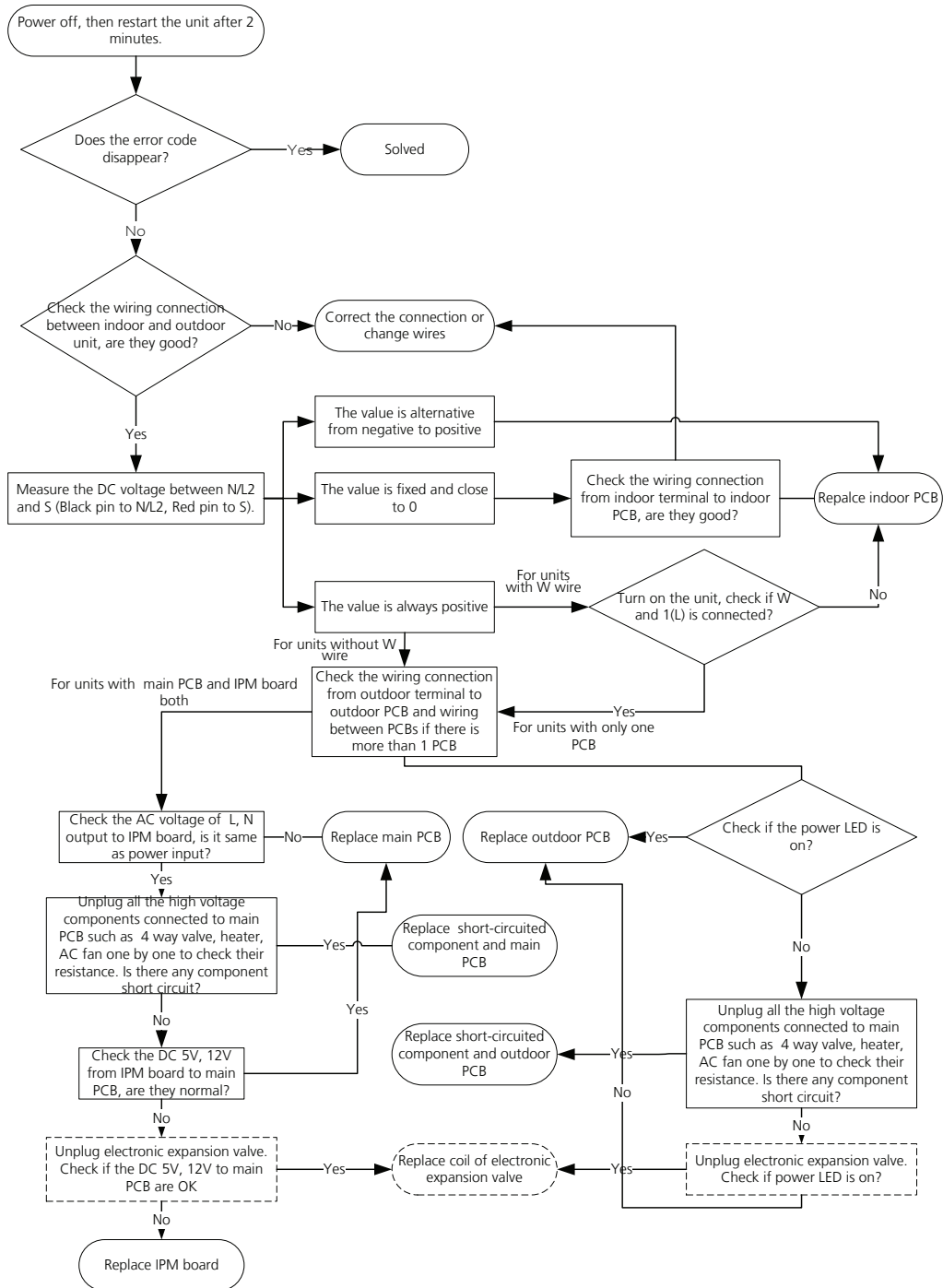

Note: For certain models, outdoor PCB could not be removed separately. In this case, the outdoor electric control box should be replaced as a whole.

Remarks:

- Use a multimeter to test the DC voltage between 2 port(or S or L2 port) and 3 port(or N or S port) of outdoor unit. The red pin of multimeter connects with 2 port(or S or L2 port) while the black pin is for 3 port(or N or S port) .
- When AC is normal running, the voltage is moving alternately as positive values and negative values
- If the outdoor unit has malfunction, the voltage has always been the positive value.
- While if the indoor unit has malfunction, the voltage has always been a certain value.

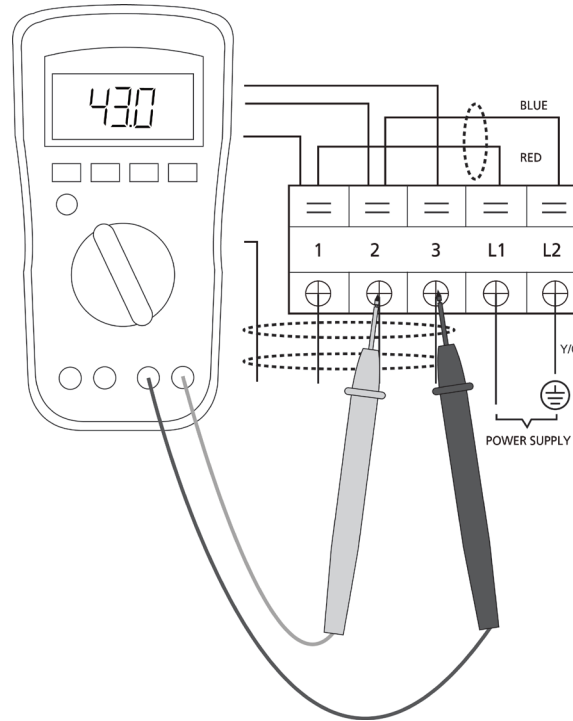

**S and N
or
L2 and S
or
2 and 3**

- Use a multimeter to test the resistance of the reactor which does not connect with capacitor.
- The normal value should be around zero ohm. Otherwise, the reactor must have malfunction.

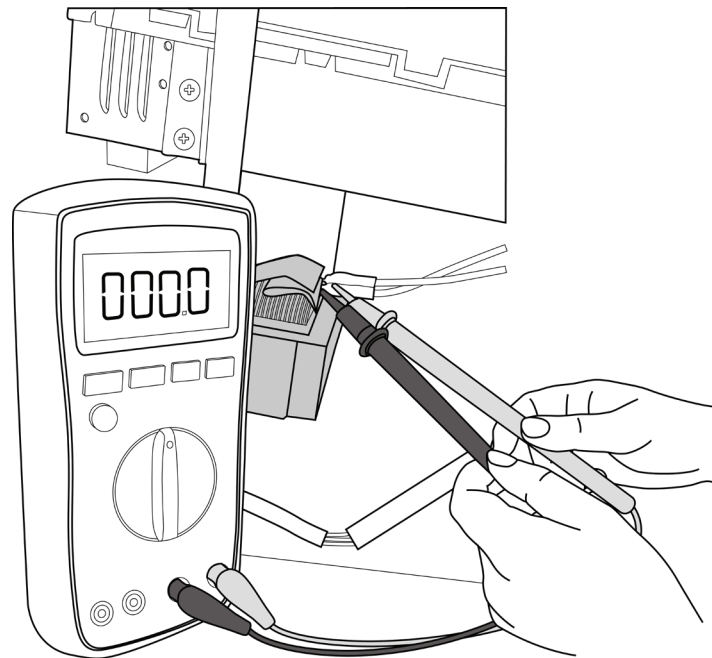

Note: The picture and the value are only for reference, actual condition and specific value may vary.

TS03: Zero crossing detection error diagnosis and solution

Description: When PCB does not receive zero crossing signal feedback for 4 minutes or the zero crossing signal time interval is abnormal.

Recommended parts to prepare:

- Connection wires
- Indoor main PCB

Troubleshooting and repair:

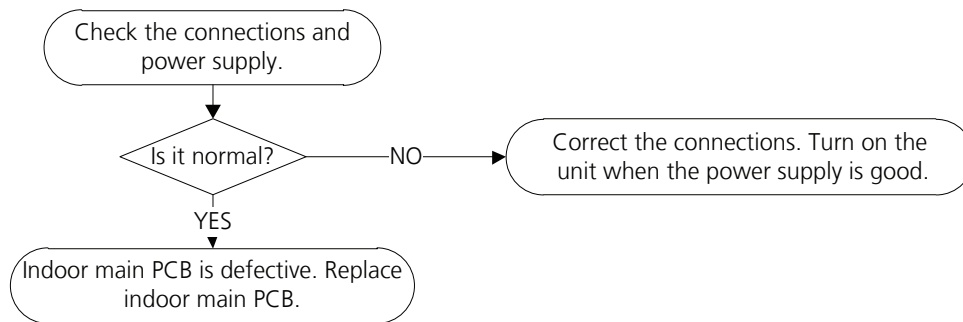

Note: Zero crossing detection error is only valid for the unit with AC fan motor, for other models, this error is invalid.

TS04-S-IDU: The Indoor fan speed is operating outside of normal range diagnosis and solution)

Description: When indoor fan speed keeps too low or too high for a certain time, the LED displays the failure code and the AC turns off.

Recommended parts to prepare:

- Connection wires
- Fan assembly
- Fan motor
- Indoor main PCB

Troubleshooting and repair:

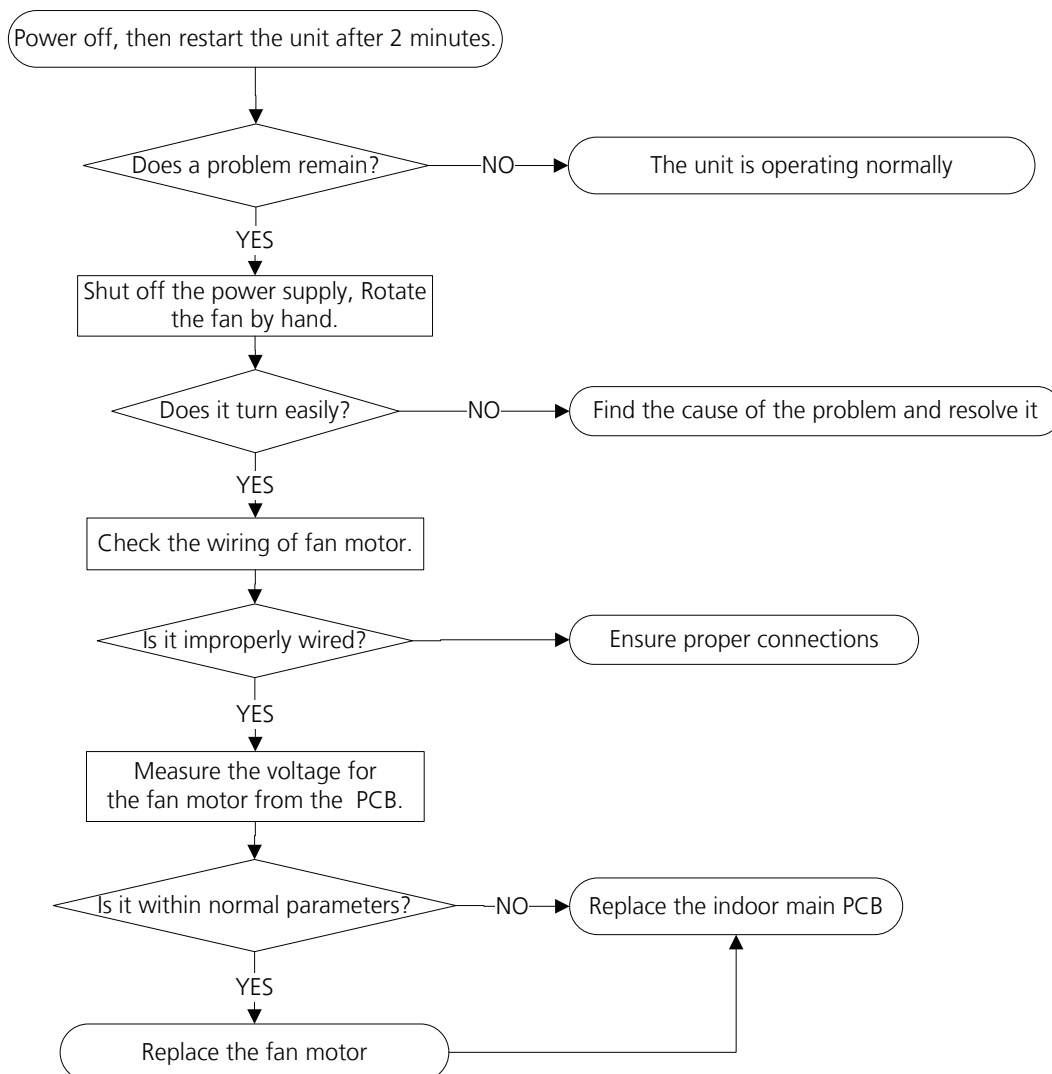

Index:

1. DC Fan Motor(control chip is in fan motor)

Power on and when the unit is in standby, measure the voltage of pin1-pin3, pin4-pin3 in fan motor connector. If the value of the voltage is not in the range showing in below table, the PCB must has problems and need to be replaced.

- DC motor voltage input and output (voltage: 220-240V~):

No.	Color	Signal	Voltage
1	Red	Vs/Vm	192V~380V
2	---	---	---
3	Black	GND	0V
4	White	Vcc	13.5-16.5V
5	Yellow	Vsp	0~6.5V
6	Blue	FG	13.5-16.5V

- DC motor voltage input and output (voltage: 115V~):

No.	Color	Signal	Voltage
1	Red	Vs/Vm	140V~190V
2	---	---	---
3	Black	GND	0V
4	White	Vcc	13.5-16.5V
5	Yellow	Vsp	0~6.5V
6	Blue	FG	13.5-16.5V

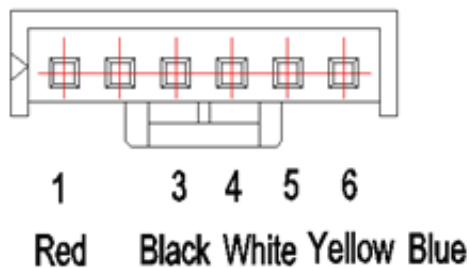

3. Indoor AC Motor

1) Power off and disconnect fan motor power cord from PCB. Measure the resistance value of each winding by using the multi-meter. The normal value show as follows .

Model	YKFG-13-4-38L YKFG-13-4-38L-4	YKFG-15-4-28-1	YKFG-20-4-10L	YKFG-20-4-5-11
Brand	Welling	Welling	Welling	Welling
Black – Red Main	345Ω	75Ω	269Ω	388Ω
Blue – Black AUX	348Ω	150Ω	224Ω	360Ω

Model	YKFG-20-4-5-19	YKFG-25-4-6-14	YKFG-28-4-3-7 YKFG-28-4-3-14	YKFG-28-4-6-5
Brand	Welling	Welling	Welling	Welling
Black – Red Main	444Ω	287Ω	231Ω	183.6Ω
Blue – Black AUX	470Ω	409Ω	414Ω	206Ω

Model	YKFG-45-4-13	YKFG-45-4-22 YKFG-45-4-22-13	YKFG-60-4-2-6	YKFG-60-4-1
Brand	Dongfang	Welling	Welling	Welling
Black – Red Main	125.2Ω	168Ω	96Ω	68Ω
Blue – Black AUX	83.8Ω	141Ω	96Ω	53Ω

Model	YKFG-20-4-5-21
Brand	Welling
Black – Red Main	450Ω
Blue – Black AUX	442Ω

2) Power on and set the unit running in fan mode at high fan speed. After running for 15 seconds, measure the voltage of pin1 and pin2. If the value of the voltage is less than 100V(208~240V power supply) or 50V (115V power supply), the PCB must has problems and need to be replaced.

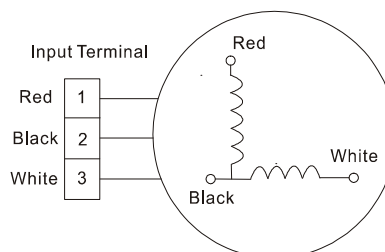

TS04-ODU: The outdoor fan speed is operating outside of normal range diagnosis and solution)

Description: When outdoor fan speed keeps too low or too high for a certain time, the LED displays the failure code and the AC turns off.

Recommended parts to prepare:

- Connection wires
- Fan assembly
- Fan motor
- Outdoor main PCB

Troubleshooting and repair:

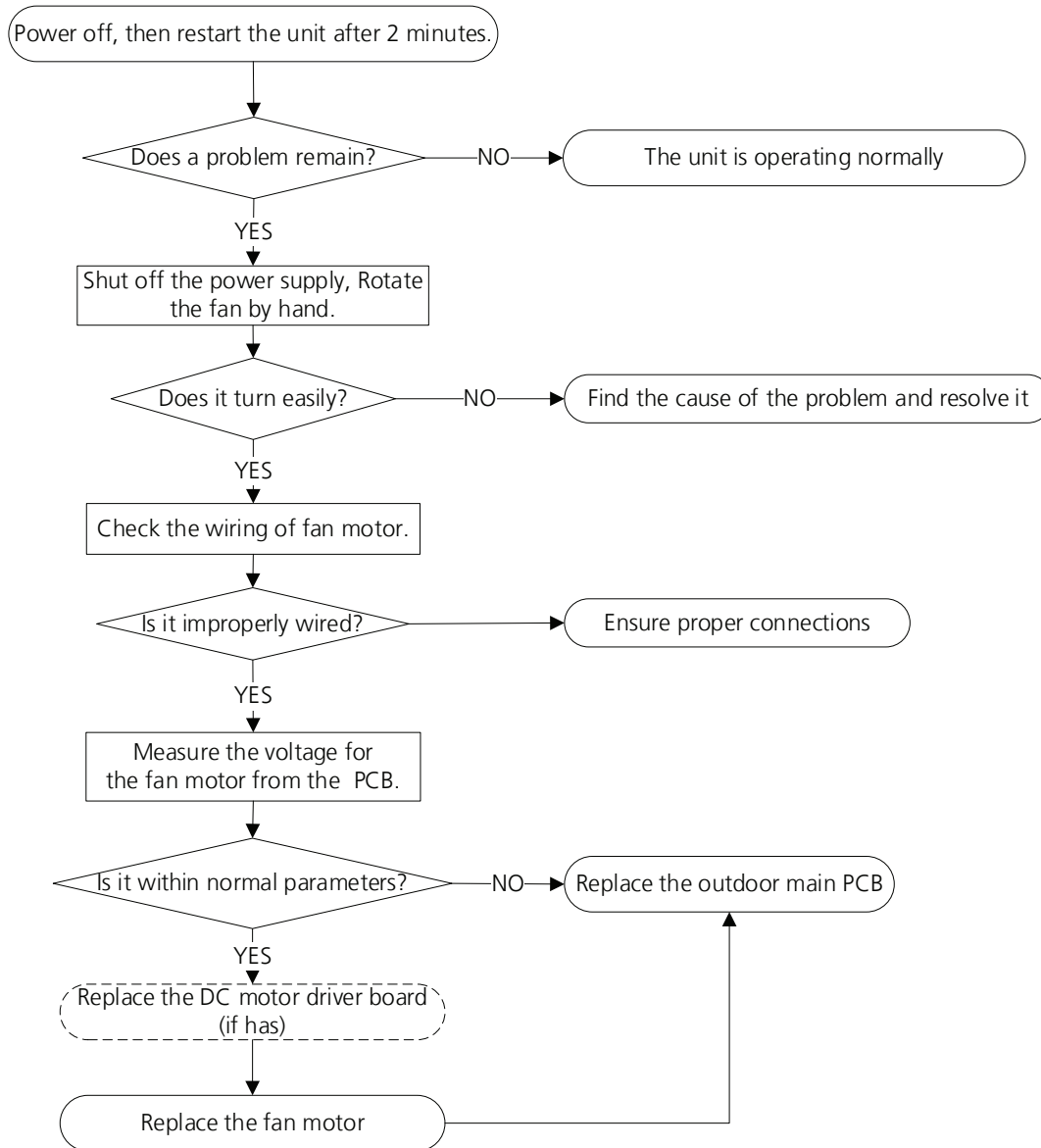

Note: For certain models, outdoor PCB could not be removed separately. In this case, the outdoor electric control box should be replaced as a whole.

Index:

1. DC Fan Motor (control chip is in outdoor PCB)

Release the UVW connector. Measure the resistance of U-V, U-W, V-W. If the resistance is not equal to each other, the fan motor must have problems and need to be replaced. Otherwise the PCB must have problems and need to be replaced.

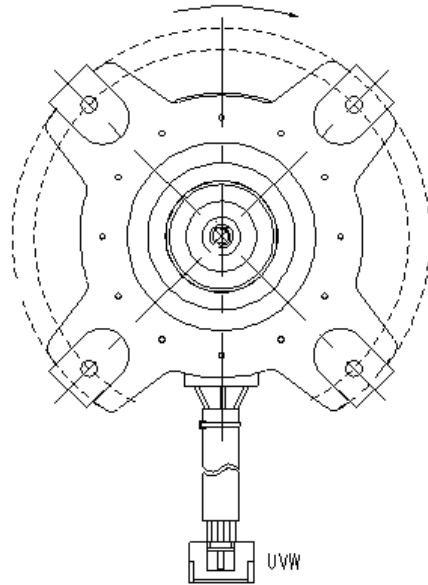

2. DC Fan Motor (control chip is in fan motor, single fan)

Power on and when the unit is in standby, measure the voltage of pin1-pin3, pin4-pin3 in fan motor connector. If the value of the voltage is not in the range showing in below table, the PCB must have problems and need to be replaced.

No.	Color	Signal	Voltage
1	Red	Vs/Vm	192V~380V
2	---	---	---
3	Black	GND	0V
4	White	Vcc	13.5-16.5V
5	Yellow	Vsp	0~6.5V
6	Blue	FG	13.5-16.5V

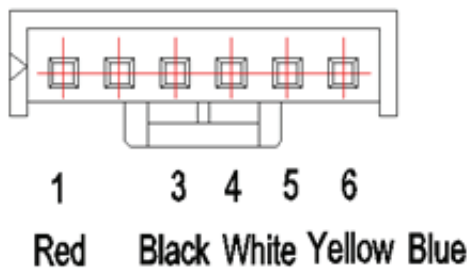

3. DC Fan Motor(for some double fan models)

Power on and when the unit is in standby, measure the voltage of CON1, pin1-pin2 and pin3-pin2 of CN1 in DC motor driver board. If the value of the voltage is not in the range showing in below tables, the outdoor main PCB must have problems and need to be replaced.

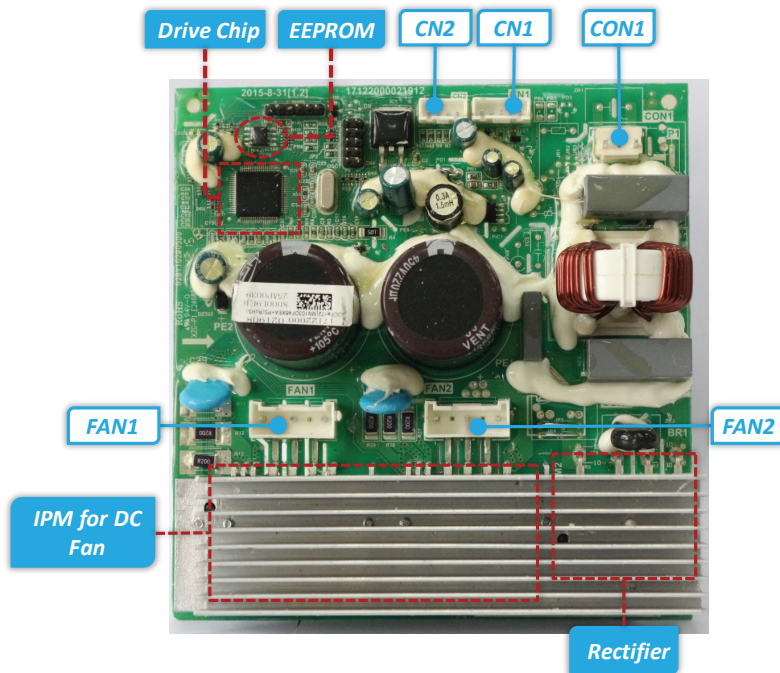

Part	Description	Parameter	Remark
CON1	Power input for the PCB	192-380V/DC	
CN1	Communication with main PCB	DC	
CN2	Test port	5V/DC	For debugging board
FAN1	UVW output for DC fan motor		
FAN2	UVW output for DC fan motor		

CN1 Communication with main PCB

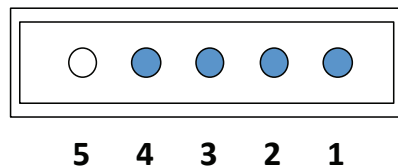

No.	Signal	Voltage
1	Vcc	13.5-16.5V
2	GND	0V
3	Vsp	0~6.5V
4	FG	13.5-16.5V
5	---	---

TS05-IDU: Open circuit or short circuit of indoor temperature sensor(T1, T2) diagnosis and solution

Description: If the sampling voltage is lower than 0.06V or higher than 4.94V, the LED displays the failure code.

Recommended parts to prepare:

- Connection wires
- Sensors
- Indoor main PCB

Troubleshooting and repair:

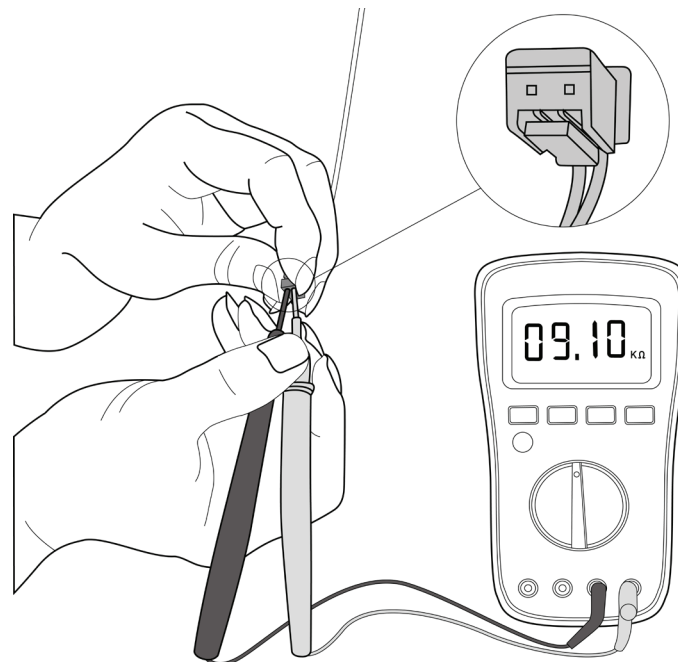
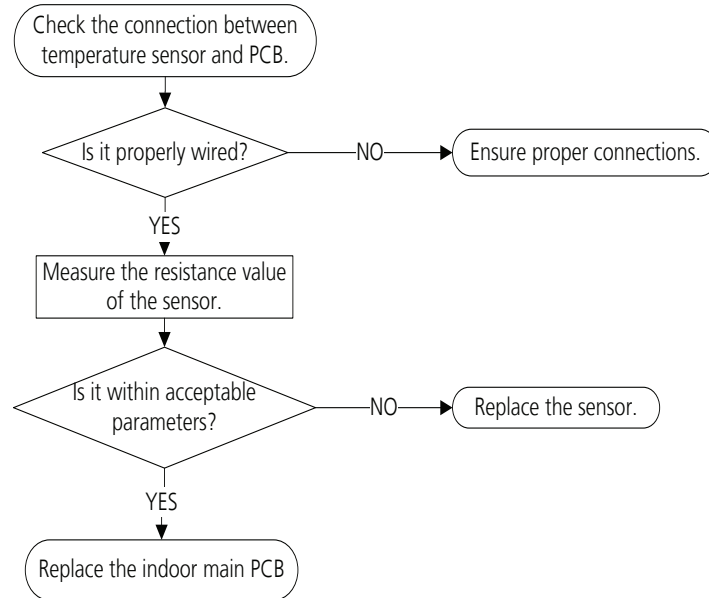

Note: This picture and the value are only for reference, actual appearance and value may vary.

TS05-ODU: Open circuit or short circuit of outdoor temperature sensor(T3, T4, TP, T2B,TH) diagnosis and solution

Description: If the sampling voltage is lower than 0.06V or higher than 4.94V, the LED displays the failure code.

Recommended parts to prepare:

- Connection wires
- Sensors
- Outdoor main PCB

Troubleshooting and repair:

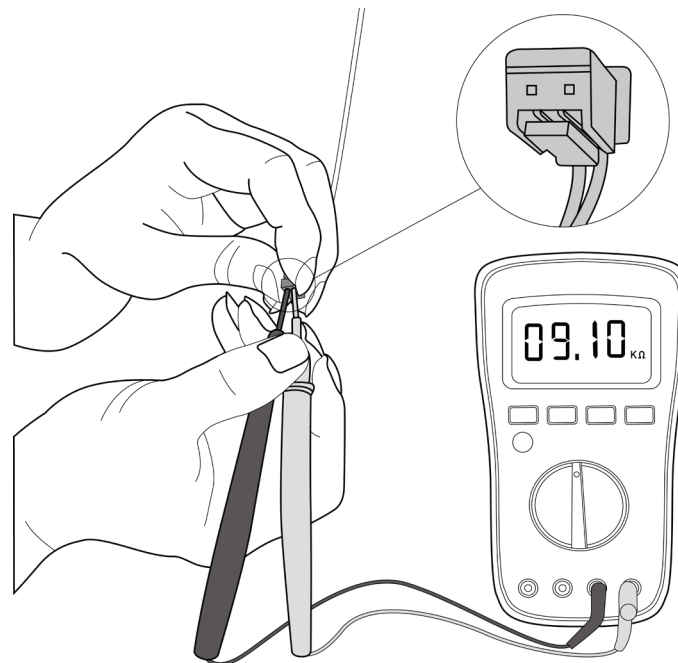
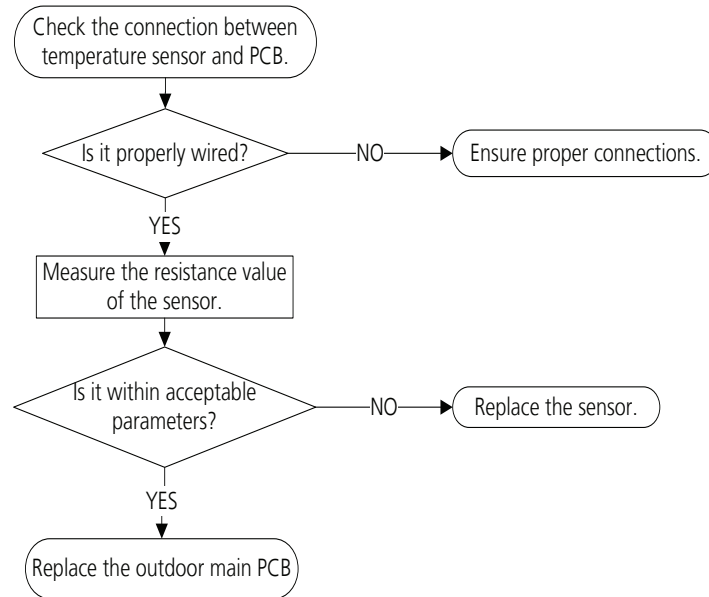

Note: For certain models, outdoor PCB could not be removed separately. In this case, the outdoor electric control box should be replaced as a whole. For certain models, outdoor unit uses combination sensor, T3,T4 and TP are the same of sensor. This picture and the value are only for reference, actual appearance and value may vary.

TS06-INV: Refrigerant Leakage Detection diagnosis and solution

Description:

Judging the abnormality of the refrigeration system according to the number of compressor stops and the changes in operating parameters caused by excessive exhaust temperature.

Recommended parts to prepare:

- Indoor PCB
- Additional refrigerant

Troubleshooting and repair:

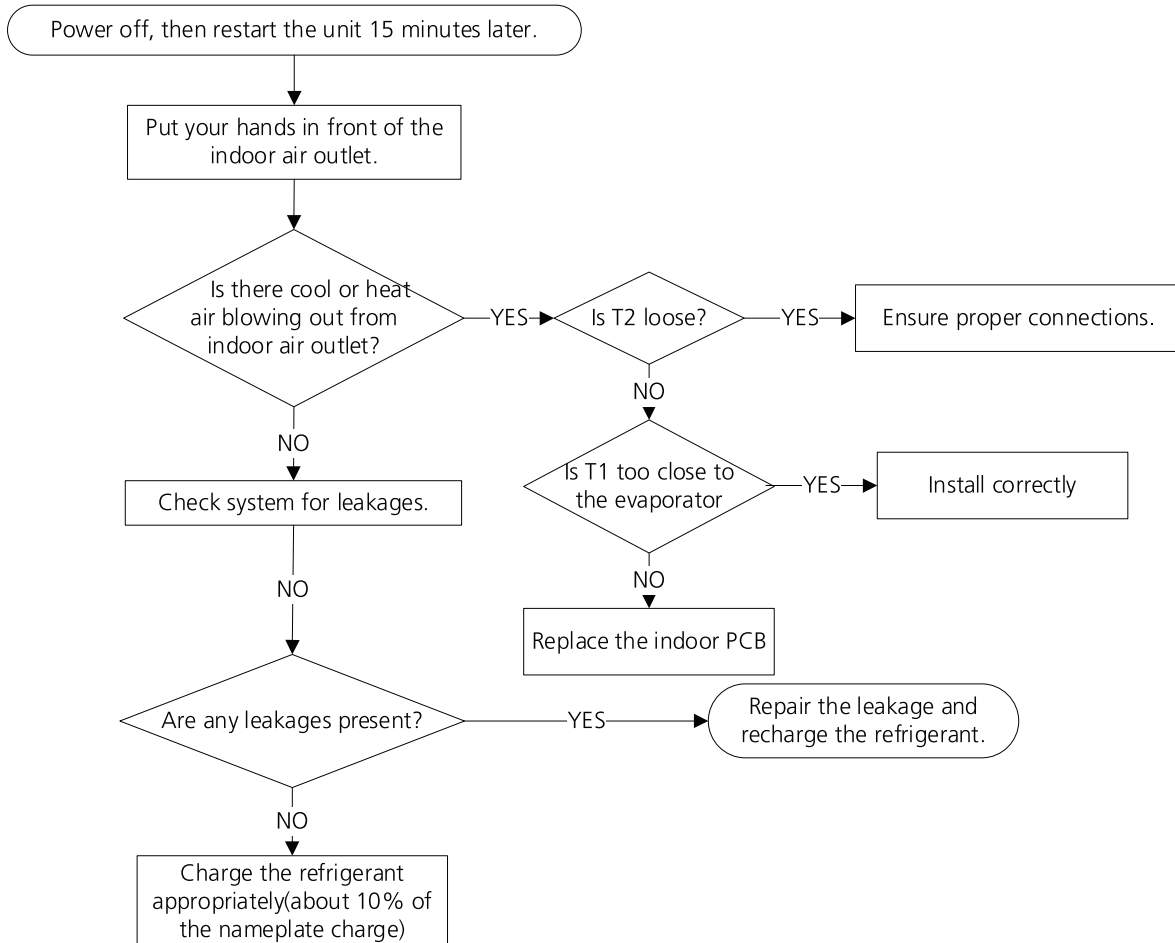

TS07: Indoor PCB / Display board communication error diagnosis and solution

Description: Indoor PCB does not receive feedback from the display board.

Recommended parts to prepare:

- Communication wire
- Indoor PCB
- Display board

Troubleshooting and repair:

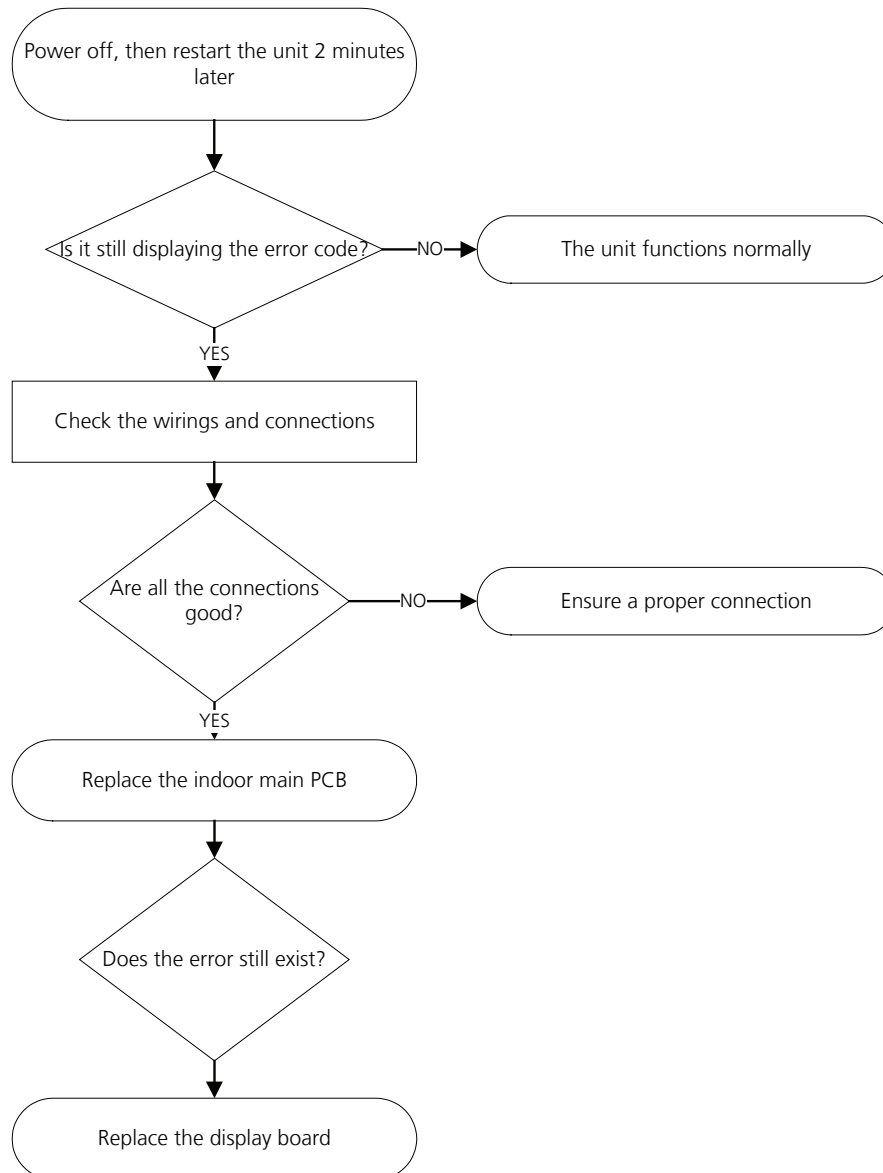

TS08-S: Current overload protection diagnosis and solution

Description: An abnormal current rise is detected by checking the specified current detection circuit.

Recommended parts to prepare:

- Connection wires
- Reactor
- Outdoor fan
- Outdoor PCB

Troubleshooting and repair:

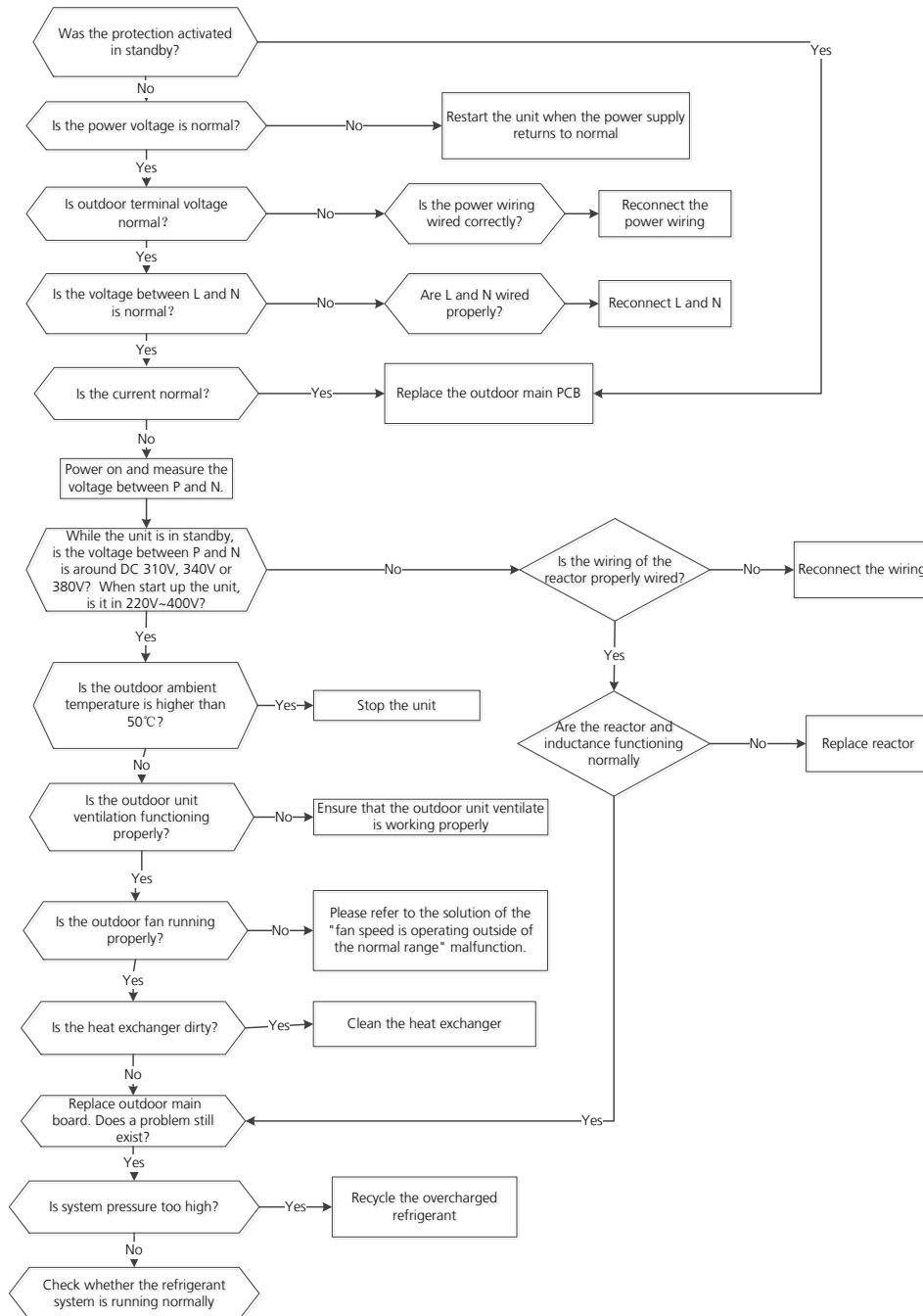

Note: For certain models, outdoor PCB could not be removed separately. In this case, the outdoor electric control box should be replaced as a whole.

TS09-S: IPM malfunction or IGBT over-strong current protection diagnosis and solution

Description: When the voltage signal the IPM sends to the compressor drive chip is abnormal, the LED displays the failure code and the AC turns off.

Recommended parts to prepare:

- Connection wires
- IPM module board
- Outdoor fan assembly
- Compressor
- Outdoor PCB

Troubleshooting and repair:

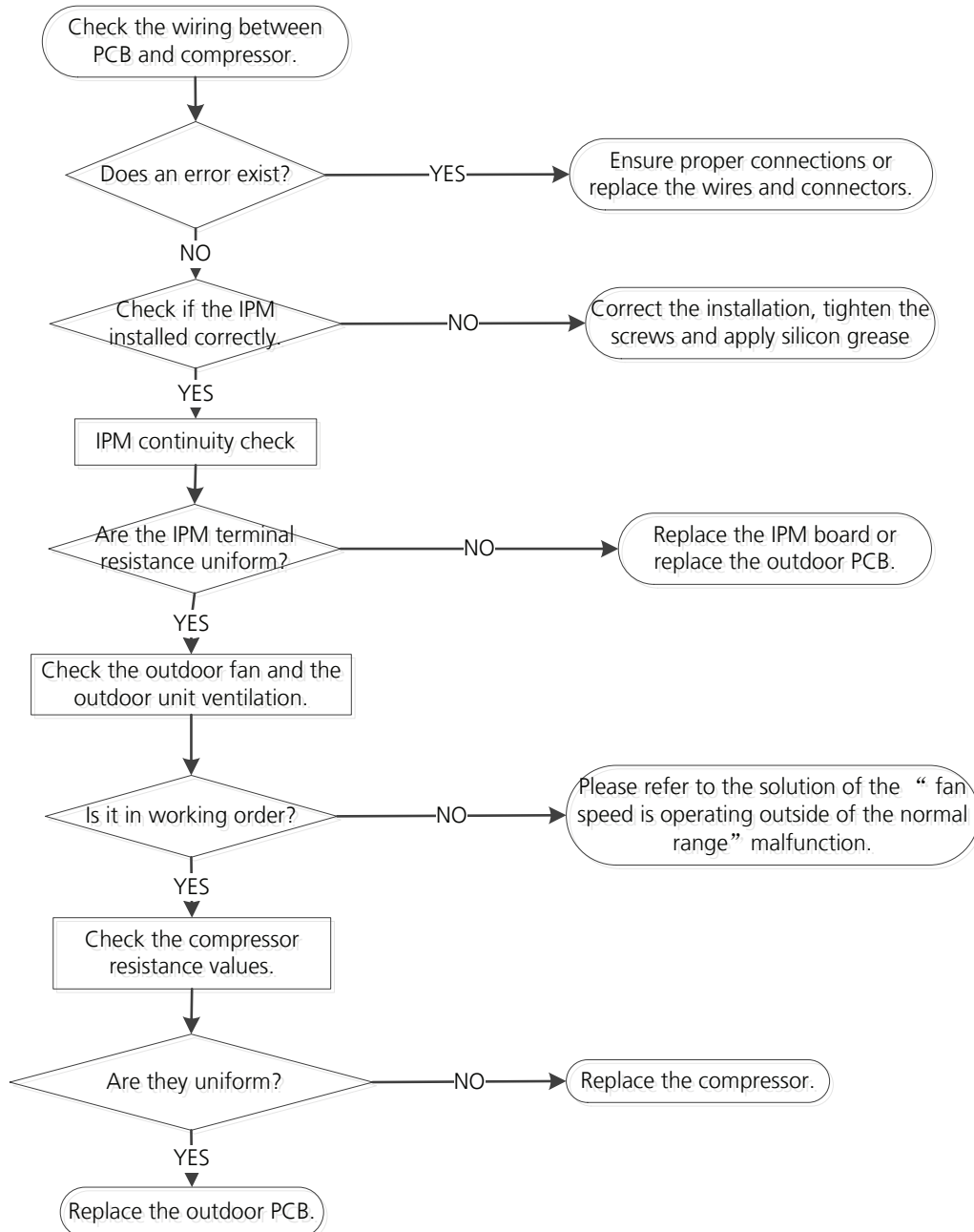

Index:

1. IPM Continuity Check

⚠ WARNING

**Electricity remains in capacitors even when the power supply is off.
Ensure the capacitors are fully discharged before troubleshooting.**

1. Turn off outdoor unit and disconnect power supply.
2. Discharge electrolytic capacitors and ensure all energy-storage unit has been discharged.
3. Disassemble outdoor PCB or disassemble IPM board.
4. Measure the resistance value between P and U(V, W, N); U(V, W) and N.

Digital tester		Resistance value	Digital tester		Resistance value
(+)Red	(-)Black	∞ (Several M Ω)	(+)Red	(-)Black	∞ (Several M Ω)
P	N		N	U	
	U				
	V				
	W				
	W	-			

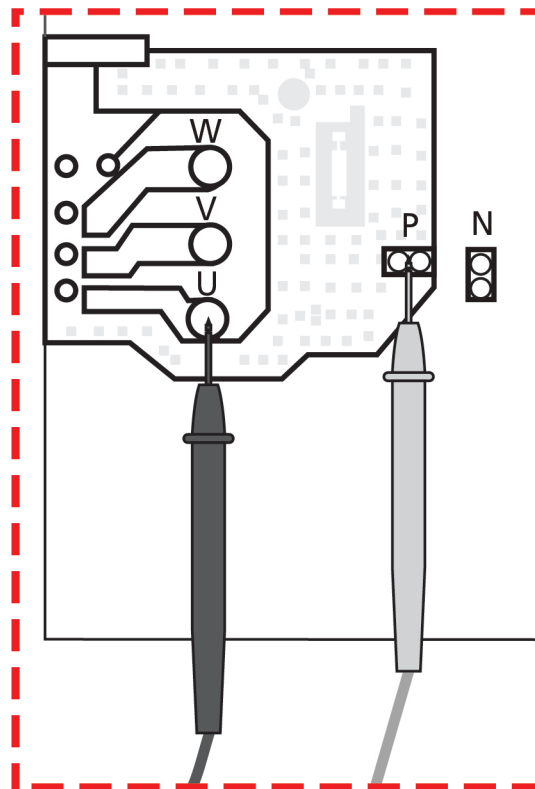

4. Compressor check

Disconnect the compressor and check the resistance between U-V, V-W and U-W, and all 3 values should be equal. If not, the compressor is faulty and should be replaced.

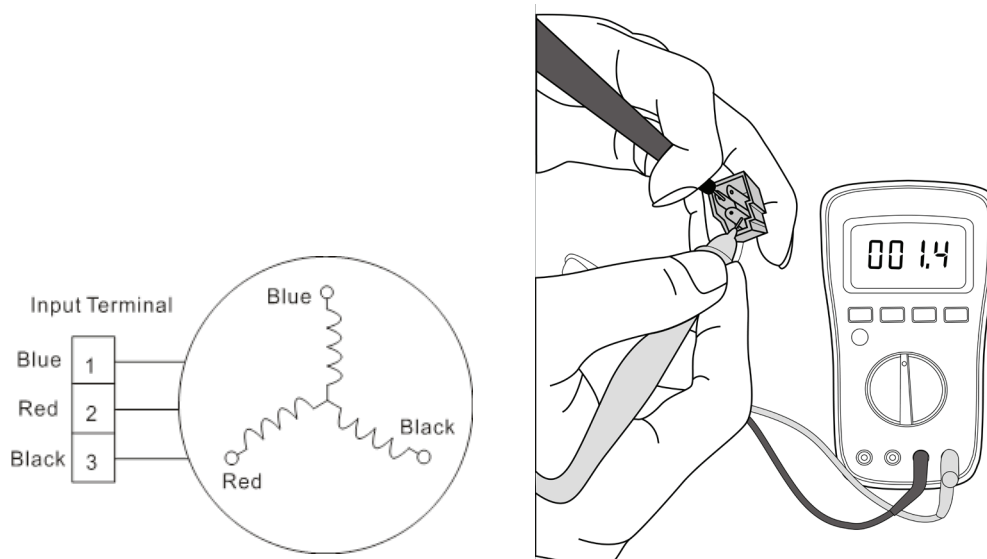

Note: The picture and the value are only for reference, actual condition and specific value may vary.

TS10-S: Over voltage or too low voltage protection diagnosis and solution

Description: Abnormal increases or decreases in voltage are detected by checking the specified voltage detection circuit.

Recommended parts to prepare:

- Power supply wires
- IPM module board
- PCB
- Reactor

Troubleshooting and repair:

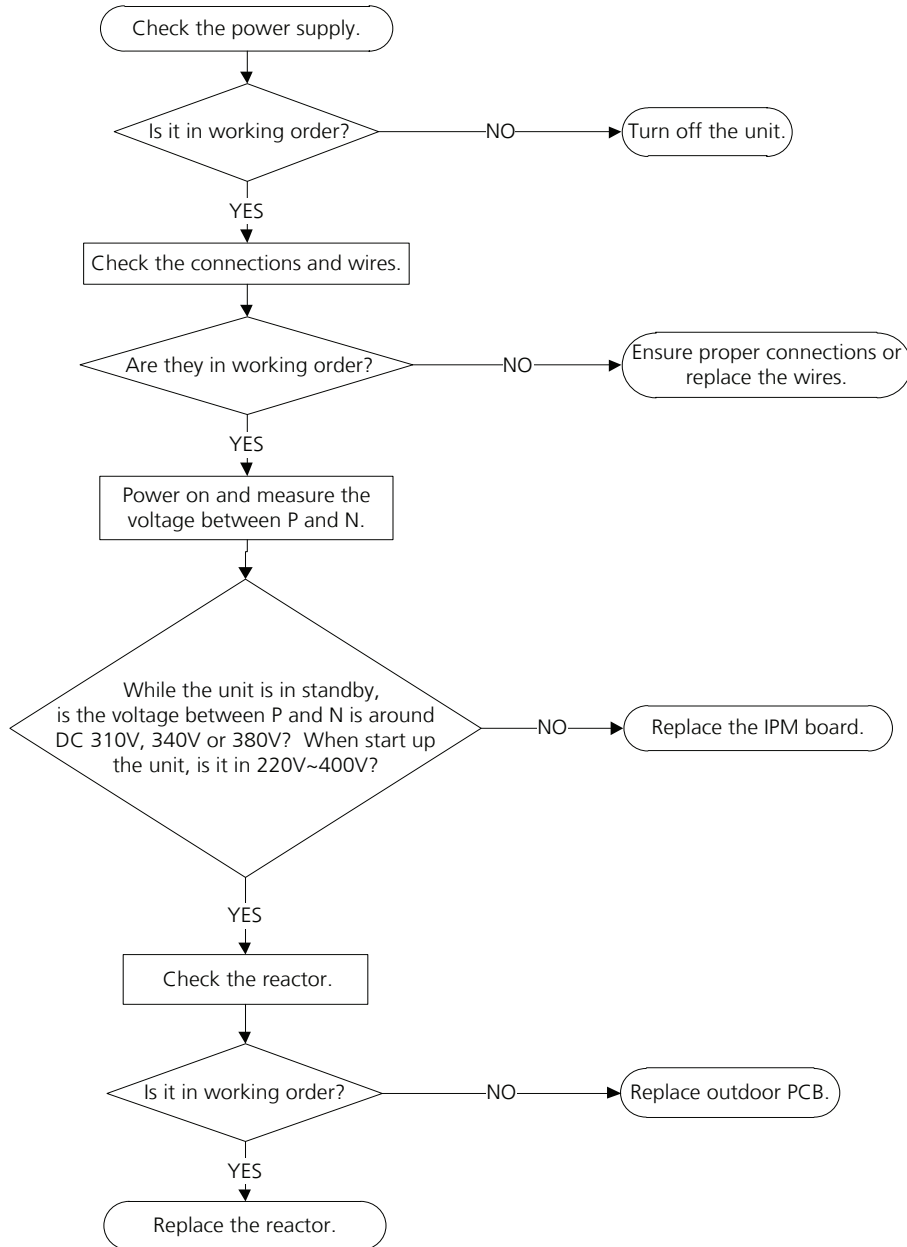

Note: For certain models, outdoor PCB could not be removed separately. In this case, the outdoor electric control box should be replaced as a whole.

TS11-S-INV: Top temperature protection of compressor or High temperature protection of IPM module or High pressure protection diagnosis and solution

Description: For some models with overload protection, If the sampling voltage is not 5V, the LED will display the failure. If the temperature of IPM module is higher than a certain value, the LED displays the failure code.

For some models with high pressure switch, outdoor pressure switch cut off the system because high pressure is higher than 4.4 MPa, the LED displays the failure code.

Recommended parts to prepare:

- Connection wires
- Outdoor PCB
- IPM module board
- High pressure protector
- System blockages

Troubleshooting and repair:

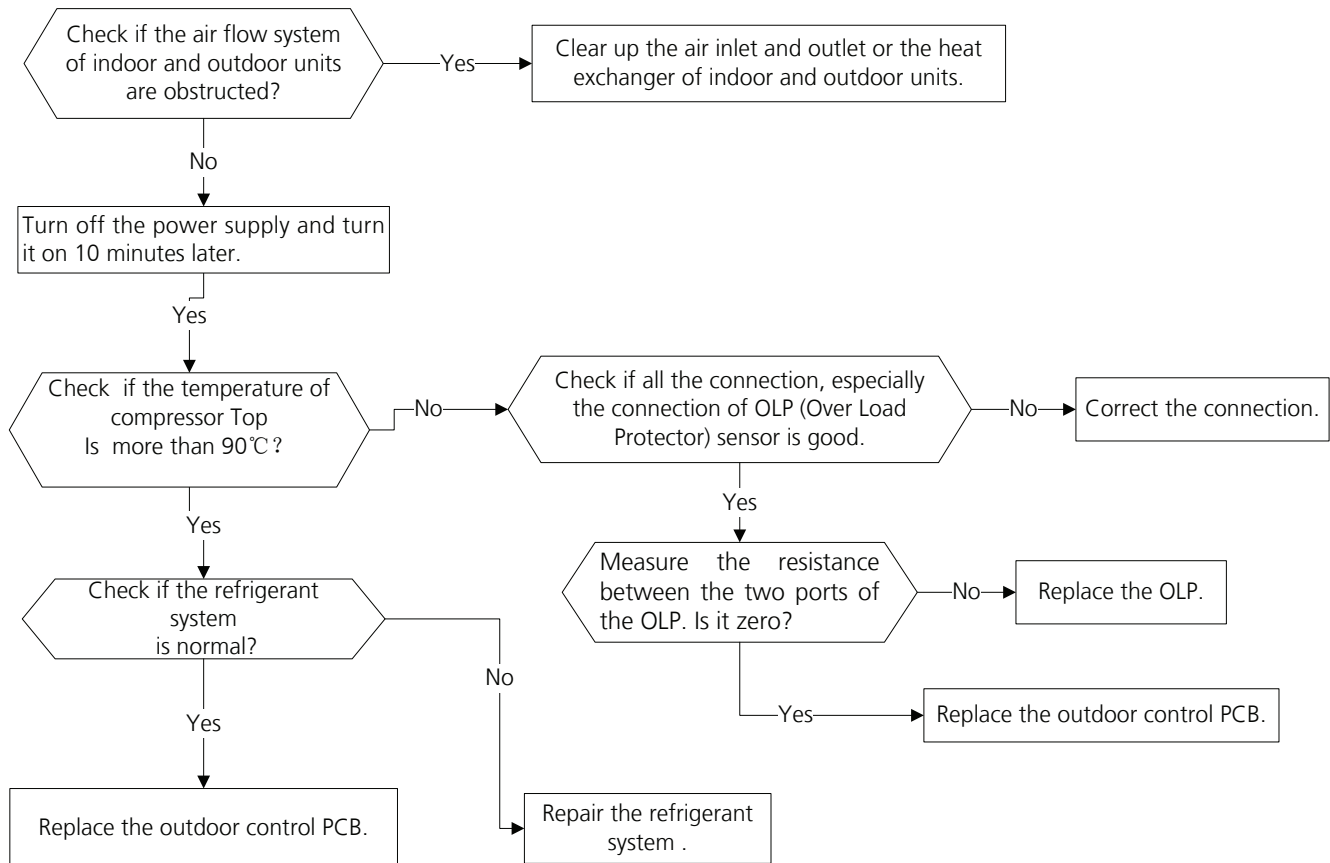

Note: For certain models, outdoor PCB could not be removed separately. In this case, the outdoor electric control box should be replaced as a whole.

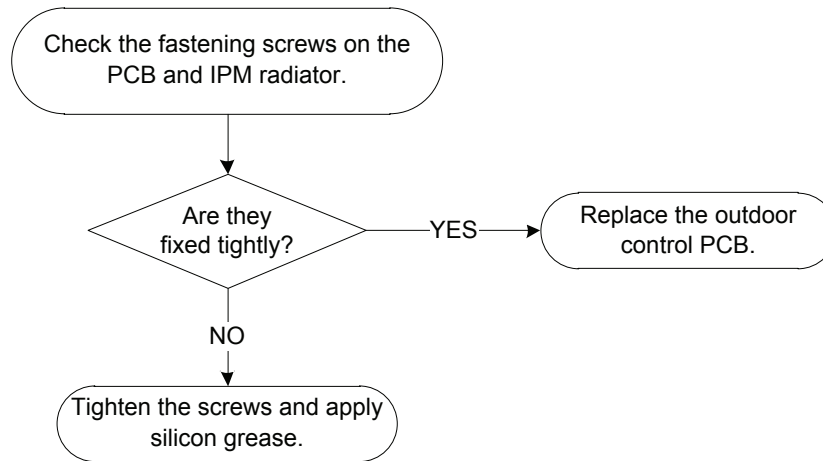

Note: For certain models, outdoor PCB could not be removed separately. In this case, the outdoor electric control box should be replaced as a whole.

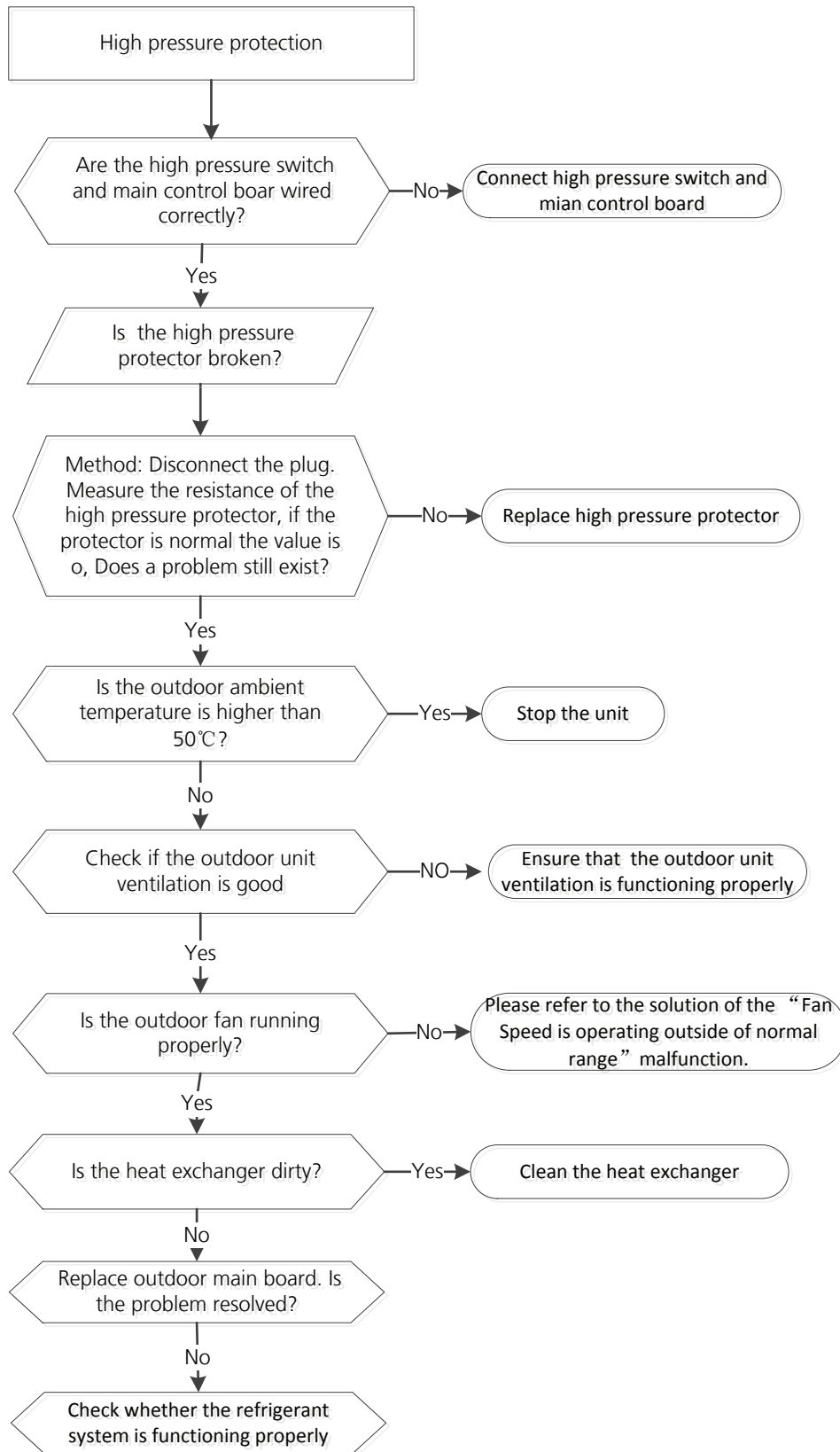

Note: For certain models, outdoor PCB could not be removed separately. In this case, the outdoor electric control box should be replaced as a whole.

TS12-S: Inverter compressor drive error diagnosis and solution

Description: An abnormal inverter compressor drive is detected by a special detection circuit, including communication signal detection, voltage detection, compressor rotation speed signal detection and so on.

Recommended parts to prepare:

- Connection wires
- IPM module board
- Outdoor fan assembly
- Compressor
- Outdoor PCB

Troubleshooting and repair:

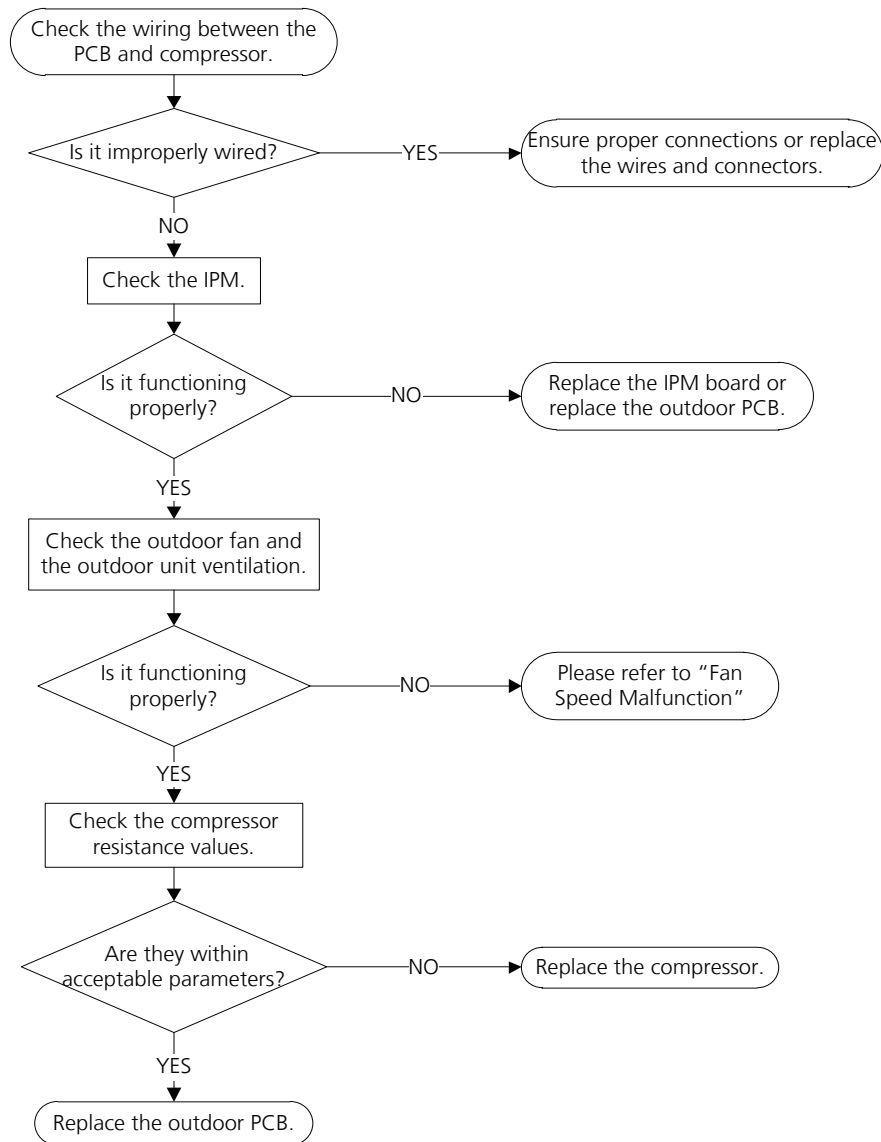

Note: For certain models, outdoor PCB could not be removed separately. In this case, the outdoor electric control box should be replaced as a whole.

TS13-INV: Low pressure protection diagnosis and solution

Description: Outdoor pressure switch cut off the system because low pressure is lower than 0.13 MPa, the LED displays the failure code.

Recommended parts to prepare:

- Connection wires
- Outdoor PCB
- Low pressure protector
- Refrigerant

Troubleshooting and repair:

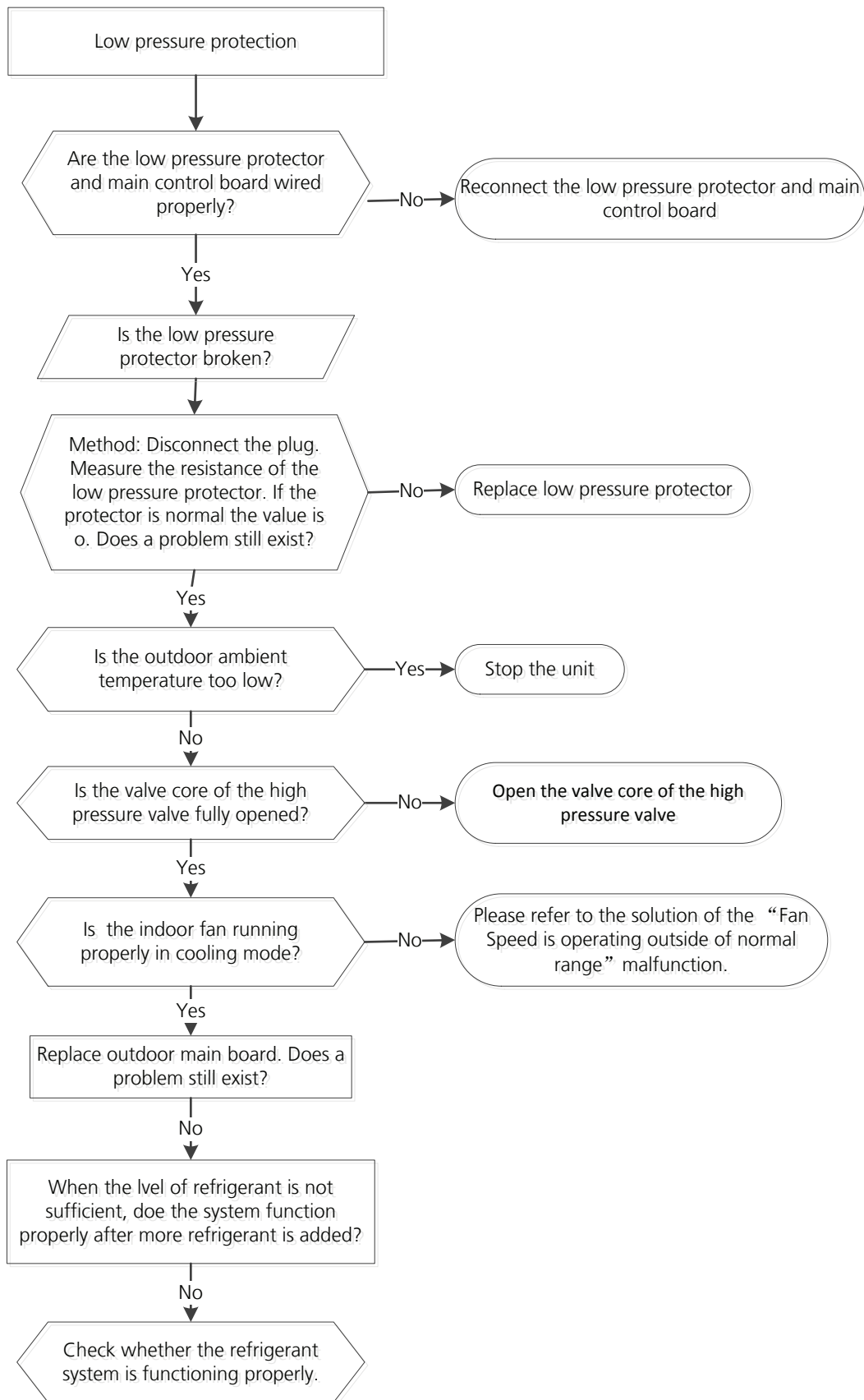

Note: For certain models, outdoor PCB could not be removed separately. In this case, the outdoor electric control box should be replaced as a whole.

TS14: Indoor units mode conflict (match with multi outdoor unit)

Description: The indoor units cannot work cooling mode and heating at same time. Heating mode has a priority.

- Suppose Indoor unit A working in cooling mode or fan mode, and indoor unit B is set to heating mode, then A will change to off and B will work in heating mode.
- Suppose Indoor unit A working in heating mode, and indoor unit B is set to cooling mode or fan mode, then B will change to stand by and A will be no change.

	Cooling mode	Heating Mode	Fan	Off
Cooling mode	No	Yes	No	No
Heating Mode	Yes	No	Yes	No
Fan	No	Yes	No	No
Off	No	No	No	No

Note:

No: No mode conflict

Yes: Mode conflict

TS33: Communication error between outdoor main chip and compressor driven chip diagnosis and solution

Description: The main chip cannot detect the compressor driven chip

Recommended parts to prepare:

- Outdoor main PCB
- Electric control box

Troubleshooting and repair:

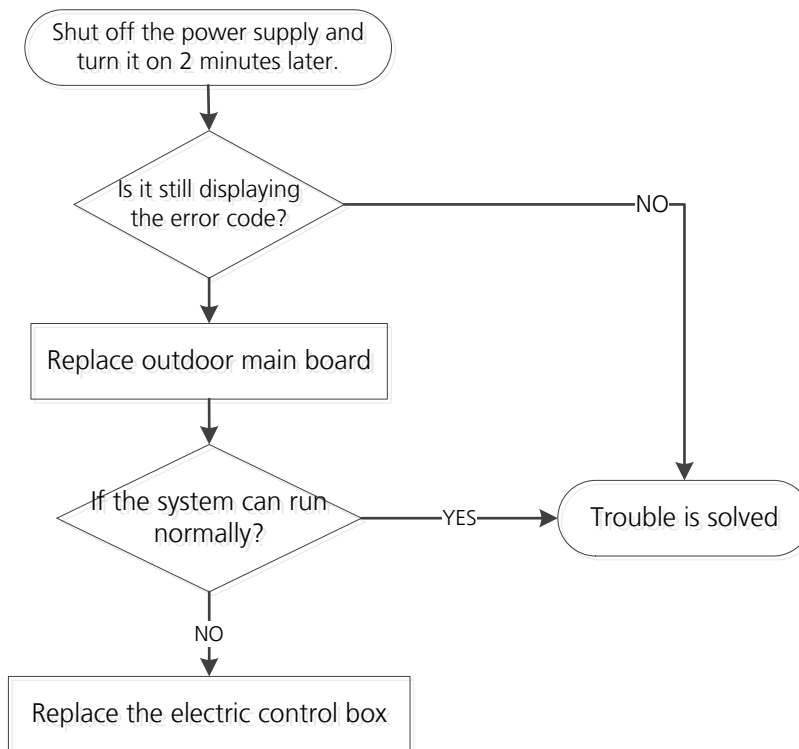

8. Check Procedures

8.1 Temperature Sensor Check

! WARNING

Be sure to turn off all power supplies or disconnect all wires to avoid electric shock. Operate after compressor and coil have returned to normal temperature in case of injury.

1. Disconnect the temperature sensor from PCB (Refer to Chapter 5&6. Indoor&Outdoor Unit Disassembly).
2. Measure the resistance value of the sensor using a multi-meter.
3. Check corresponding temperature sensor resistance value table (Refer to Chapter 8. Appendix).

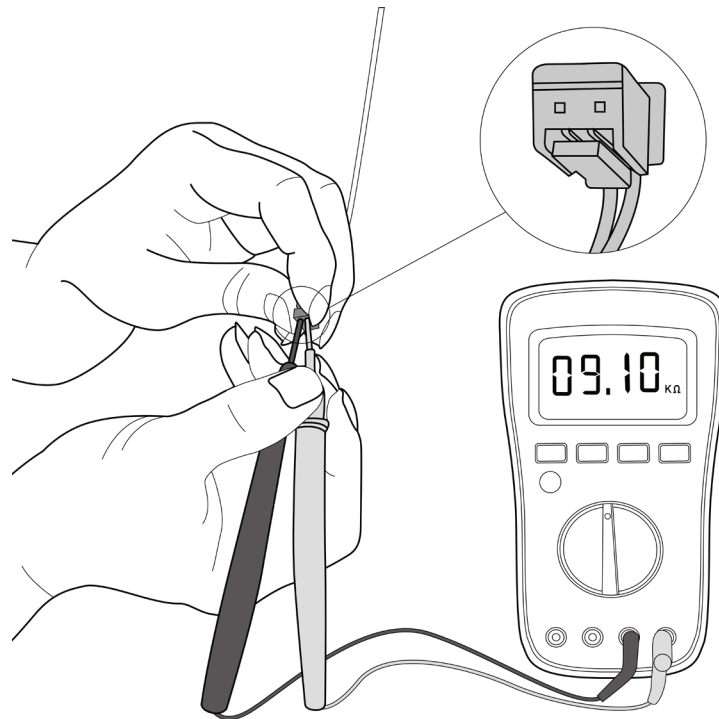

Note: The picture and the value are only for reference, actual condition and specific value may vary.

8.2 Compressor Check

1. Disconnect the compressor power cord from outdoor PCB (Refer to Chapter 6. Outdoor Unit Disassembly).
2. Measure the resistance value of each winding using a multi-meter.
3. Check the resistance value of each winding in the following table.

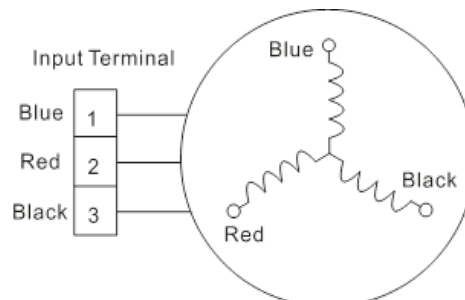

Resistance Value	ASM135D23UFZ	ATQ420D1UMU	ASN98D22UFZ	ATF235D22UMT	ATQ360D1UMU
Blue-Red	1.75Ω	0.37Ω	1.57Ω	0.75Ω	0.37Ω
Blue-Black					
Red-Black					

Resistance Value	ATM115D43UFZ2	ATF250D22UMT	ATF310D43UMT	KSK103D33UEZ3(YJ)	ASM98D32UFZ
Blue-Red	1.87Ω	0.75Ω	0.65Ω	2.13Ω	2.2Ω
Blue-Black					
Red-Black					

Resistance Value	ASN140D21UFZ	ASK89D29UEZD	KSN140D21UFZ	KTM240D57UMT	KSK103D33UEZ3
Blue-Red	1.28Ω	1.99Ω	1.28Ω	0.62Ω	2.13Ω
Blue-Black					
Red-Black					

Resistance Value	KTF310D43UMT	KTQ420D1UMU	ATN150D30UFZA	KTM240D43UKT	KTN110D42UFZ
Blue-Red	0.65Ω	0.37Ω	1.03Ω	1.03Ω	1.82Ω
Blue-Black					
Red-Black					

Resistance Value	KTF250D22UMT	KSN140D58UFZ
Blue-Red	0.75Ω	1.86Ω
Blue-Black		
Red-Black		

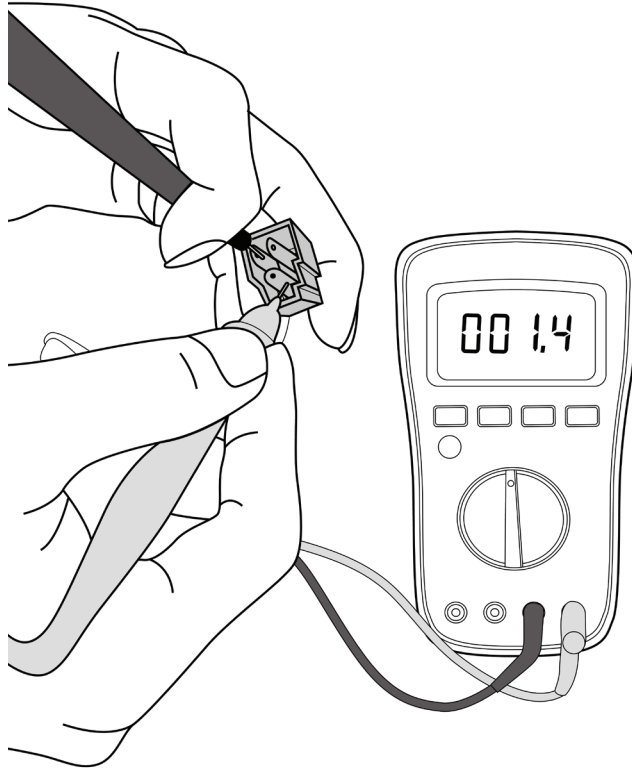

Note: The picture and the value are only for reference, actual condition and specific value may vary.

8.3 IPM Continuity Check

⚠ WARNING

Electricity remains in capacitors even when the power supply is off. Ensure the capacitors are fully discharged before troubleshooting.

1. Turn off outdoor unit and disconnect power supply.
2. Discharge electrolytic capacitors and ensure all energy-storage unit has been discharged.
3. Disassemble outdoor PCB or disassemble IPM board.
4. Measure the resistance value between P and U(V, W, N); U(V, W) and N.

Digital tester		Resistance value	Digital tester		Resistance value
(+)Red	(-)Black	∞ (Several MΩ)	(+)Red	(-)Black	∞ (Several MΩ)
P	N		U	N	
	U		V		
	V		W		
	W		-		

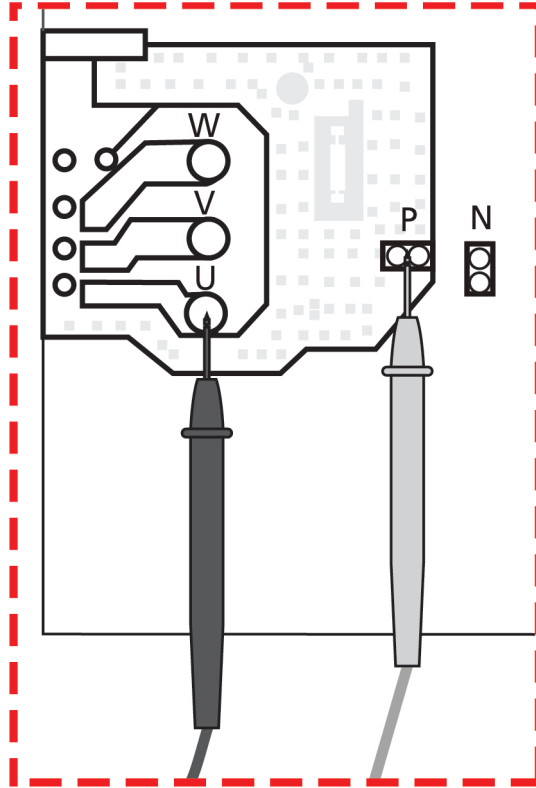

Note: The picture and the value are only for reference, actual condition and specific value may vary.

8.4 4-way Valve Check

1. Power on, use a digital tester to measure the voltage, when the unit operates in cooling, it is 0V. When the unit operates in heating, it is about 230VAC.

If the value of the voltage is not in the range, the PCB must have problems and need to be replaced.

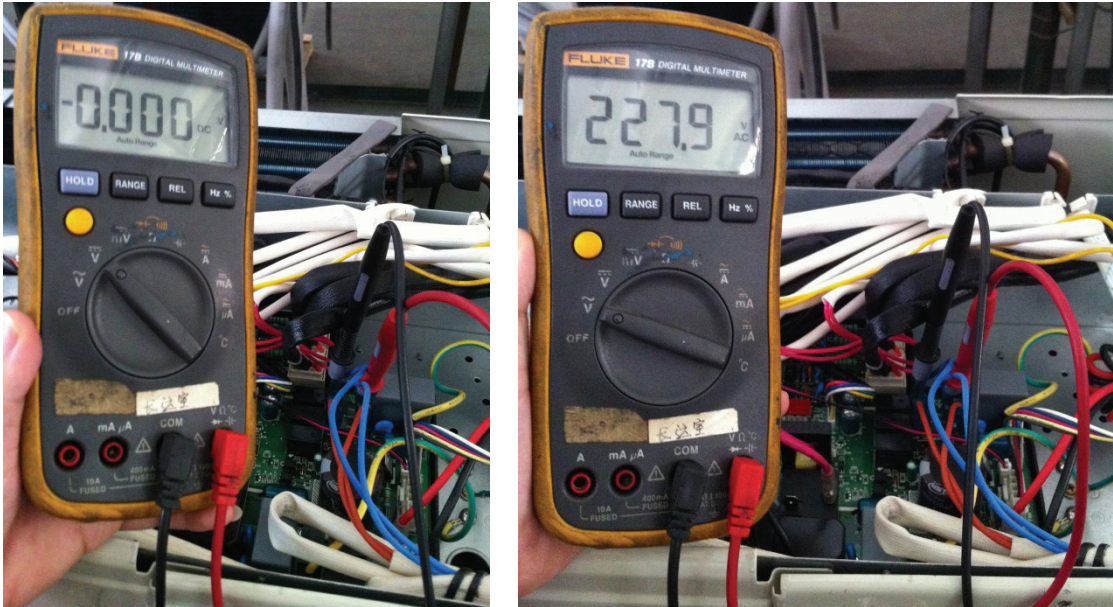

2 Turn off the power, use a digital tester to measure the resistance. The value should be 1.8~2.5 k Ω .

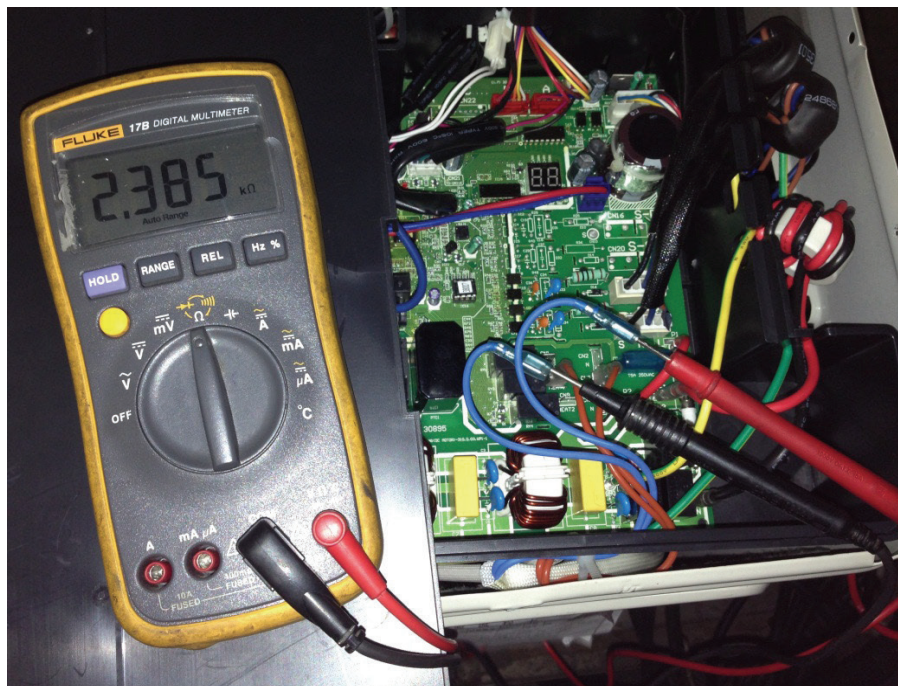

8.5 EXV Check

! WARNING

**Electricity remains in capacitors even when the power supply is off.
Ensure the capacitors are fully discharged before troubleshooting.**

1. Disconnect the connector from outdoor PCB.
2. Measure the resistance value of each winding using a multi-meter.
3. Check the resistance value of each winding in the following table.

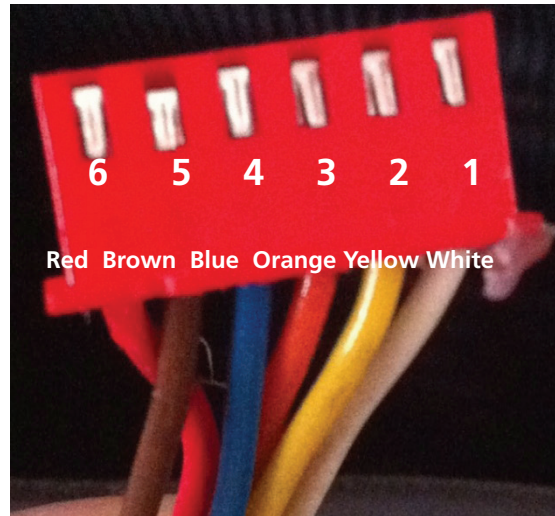

Color of lead winding	Normal Value
Red- Blue	About 50Ω
Red - Yellow	
Brown-Orange	
Brown-White	

Appendix

Contents

- i) Temperature Sensor Resistance Value Table for T1, T2, T3, and T4 (°C – K)2
- ii) Temperature Sensor Resistance Value Table for TP (for some units)(°C --K)3
- iii) Pressure On Service Port4

i) Temperature Sensor Resistance Value Table for T1,T2,T3 and T4 (°C – K)

°C	°F	K Ohm	°C	°F	K Ohm	°C	°F	K Ohm	°C	°F	K Ohm
-20	-4	115.266	20	68	12.6431	60	140	2.35774	100	212	0.62973
-19	-2	108.146	21	70	12.0561	61	142	2.27249	101	214	0.61148
-18	0	101.517	22	72	11.5	62	144	2.19073	102	216	0.59386
-17	1	96.3423	23	73	10.9731	63	145	2.11241	103	217	0.57683
-16	3	89.5865	24	75	10.4736	64	147	2.03732	104	219	0.56038
-15	5	84.219	25	77	10	65	149	1.96532	105	221	0.54448
-14	7	79.311	26	79	9.55074	66	151	1.89627	106	223	0.52912
-13	9	74.536	27	81	9.12445	67	153	1.83003	107	225	0.51426
-12	10	70.1698	28	82	8.71983	68	154	1.76647	108	226	0.49989
-11	12	66.0898	29	84	8.33566	69	156	1.70547	109	228	0.486
-10	14	62.2756	30	86	7.97078	70	158	1.64691	110	230	0.47256
-9	16	58.7079	31	88	7.62411	71	160	1.59068	111	232	0.45957
-8	18	56.3694	32	90	7.29464	72	162	1.53668	112	234	0.44699
-7	19	52.2438	33	91	6.98142	73	163	1.48481	113	235	0.43482
-6	21	49.3161	34	93	6.68355	74	165	1.43498	114	237	0.42304
-5	23	46.5725	35	95	6.40021	75	167	1.38703	115	239	0.41164
-4	25	44	36	97	6.13059	76	169	1.34105	116	241	0.4006
-3	27	41.5878	37	99	5.87359	77	171	1.29078	117	243	0.38991
-2	28	39.8239	38	100	5.62961	78	172	1.25423	118	244	0.37956
-1	30	37.1988	39	102	5.39689	79	174	1.2133	119	246	0.36954
0	32	35.2024	40	104	5.17519	80	176	1.17393	120	248	0.35982
1	34	33.3269	41	106	4.96392	81	178	1.13604	121	250	0.35042
2	36	31.5635	42	108	4.76253	82	180	1.09958	122	252	0.3413
3	37	29.9058	43	109	4.5705	83	181	1.06448	123	253	0.33246
4	39	28.3459	44	111	4.38736	84	183	1.03069	124	255	0.3239
5	41	26.8778	45	113	4.21263	85	185	0.99815	125	257	0.31559
6	43	25.4954	46	115	4.04589	86	187	0.96681	126	259	0.30754
7	45	24.1932	47	117	3.88673	87	189	0.93662	127	261	0.29974
8	46	22.5662	48	118	3.73476	88	190	0.90753	128	262	0.29216
9	48	21.8094	49	120	3.58962	89	192	0.8795	129	264	0.28482
10	50	20.7184	50	122	3.45097	90	194	0.85248	130	266	0.2777
11	52	19.6891	51	124	3.31847	91	196	0.82643	131	268	0.27078
12	54	18.7177	52	126	3.19183	92	198	0.80132	132	270	0.26408
13	55	17.8005	53	127	3.07075	93	199	0.77709	133	271	0.25757
14	57	16.9341	54	129	2.95896	94	201	0.75373	134	273	0.25125
15	59	16.1156	55	131	2.84421	95	203	0.73119	135	275	0.24512
16	61	15.3418	56	133	2.73823	96	205	0.70944	136	277	0.23916
17	63	14.6181	57	135	2.63682	97	207	0.68844	137	279	0.23338
18	64	13.918	58	136	2.53973	98	208	0.66818	138	280	0.22776
19	66	13.2631	59	138	2.44677	99	210	0.64862	139	282	0.22231

ii) Temperature Sensor Resistance Value Table for TP(for some units) (°C --K)

°C	°F	K Ohm	°C	°F	K Ohm	°C	°F	K Ohm	°C	°F	K Ohm
-20	-4	542.7	20	68	68.66	60	140	13.59	100	212	3.702
-19	-2	511.9	21	70	65.62	61	142	13.11	101	214	3.595
-18	0	483	22	72	62.73	62	144	12.65	102	216	3.492
-17	1	455.9	23	73	59.98	63	145	12.21	103	217	3.392
-16	3	430.5	24	75	57.37	64	147	11.79	104	219	3.296
-15	5	406.7	25	77	54.89	65	149	11.38	105	221	3.203
-14	7	384.3	26	79	52.53	66	151	10.99	106	223	3.113
-13	9	363.3	27	81	50.28	67	153	10.61	107	225	3.025
-12	10	343.6	28	82	48.14	68	154	10.25	108	226	2.941
-11	12	325.1	29	84	46.11	69	156	9.902	109	228	2.86
-10	14	307.7	30	86	44.17	70	158	9.569	110	230	2.781
-9	16	291.3	31	88	42.33	71	160	9.248	111	232	2.704
-8	18	275.9	32	90	40.57	72	162	8.94	112	234	2.63
-7	19	261.4	33	91	38.89	73	163	8.643	113	235	2.559
-6	21	247.8	34	93	37.3	74	165	8.358	114	237	2.489
-5	23	234.9	35	95	35.78	75	167	8.084	115	239	2.422
-4	25	222.8	36	97	34.32	76	169	7.82	116	241	2.357
-3	27	211.4	37	99	32.94	77	171	7.566	117	243	2.294
-2	28	200.7	38	100	31.62	78	172	7.321	118	244	2.233
-1	30	190.5	39	102	30.36	79	174	7.086	119	246	2.174
0	32	180.9	40	104	29.15	80	176	6.859	120	248	2.117
1	34	171.9	41	106	28	81	178	6.641	121	250	2.061
2	36	163.3	42	108	26.9	82	180	6.43	122	252	2.007
3	37	155.2	43	109	25.86	83	181	6.228	123	253	1.955
4	39	147.6	44	111	24.85	84	183	6.033	124	255	1.905
5	41	140.4	45	113	23.89	85	185	5.844	125	257	1.856
6	43	133.5	46	115	22.89	86	187	5.663	126	259	1.808
7	45	127.1	47	117	22.1	87	189	5.488	127	261	1.762
8	46	121	48	118	21.26	88	190	5.32	128	262	1.717
9	48	115.2	49	120	20.46	89	192	5.157	129	264	1.674
10	50	109.8	50	122	19.69	90	194	5	130	266	1.632
11	52	104.6	51	124	18.96	91	196	4.849			
12	54	99.69	52	126	18.26	92	198	4.703			
13	55	95.05	53	127	17.58	93	199	4.562			
14	57	90.66	54	129	16.94	94	201	4.426			
15	59	86.49	55	131	16.32	95	203	4.294			
16	61	82.54	56	133	15.73	96	205	4.167			
17	63	78.79	57	135	15.16	97	207	4.045			
18	64	75.24	58	136	14.62	98	208	3.927			
19	66	71.86	59	138	14.09	99	210	3.812			

iii) Pressure On Service Port

Cooling chart(R410A):

°F(°C)	ODU(DB)		0(-17)	5(-15)	15(-9.44)	45(7.22)	75(23.89)	85(29.44)	95(35)	105(40.56)	115(46.11)	120(48.89)
	IDU(DB/WB)											
BAR	70/59 (21.11/15)		6.4	6.5	7.3	8.0	8.2	7.8	8.1	8.6	10.1	10.6
	75/63 (23.89/17.22)		6.7	6.8	7.9	8.6	8.6	8.3	8.7	9.1	10.7	11.2
	80/67 (26.67/19.44)		7.1	7.2	8.5	9.5	9.3	8.9	9.1	9.6	11.2	11.9
	90/73 (32.22/22.78)		7.7	7.8	9.6	10.5	10.3	9.5	10.0	10.6	12.4	13.0
PSI	70/59 (21.11/15)		93	94	106	116	119	113	117	125	147	154
	75/63 (23.89/17.22)		97	99	115	125	124	120	126	132	155	162
	80/67 (26.67/19.44)		103	104	123	138	135	129	132	140	162	173
	90/73 (32.22/22.78)		112	113	139	152	149	138	145	154	180	189
MPa	70/59 (21.11/15)		0.64	0.65	0.73	0.8	0.82	0.78	0.81	0.86	1.01	1.06
	75/63 (23.89/17.22)		0.67	0.68	0.79	0.86	0.86	0.83	0.87	0.91	1.07	1.12
	80/67 (26.67/19.44)		0.71	0.72	0.85	0.95	0.93	0.89	0.91	0.96	1.12	1.19
	90/73 (32.22/22.78)		0.77	0.78	0.96	1.05	1.03	0.95	1	1.06	1.24	1.3

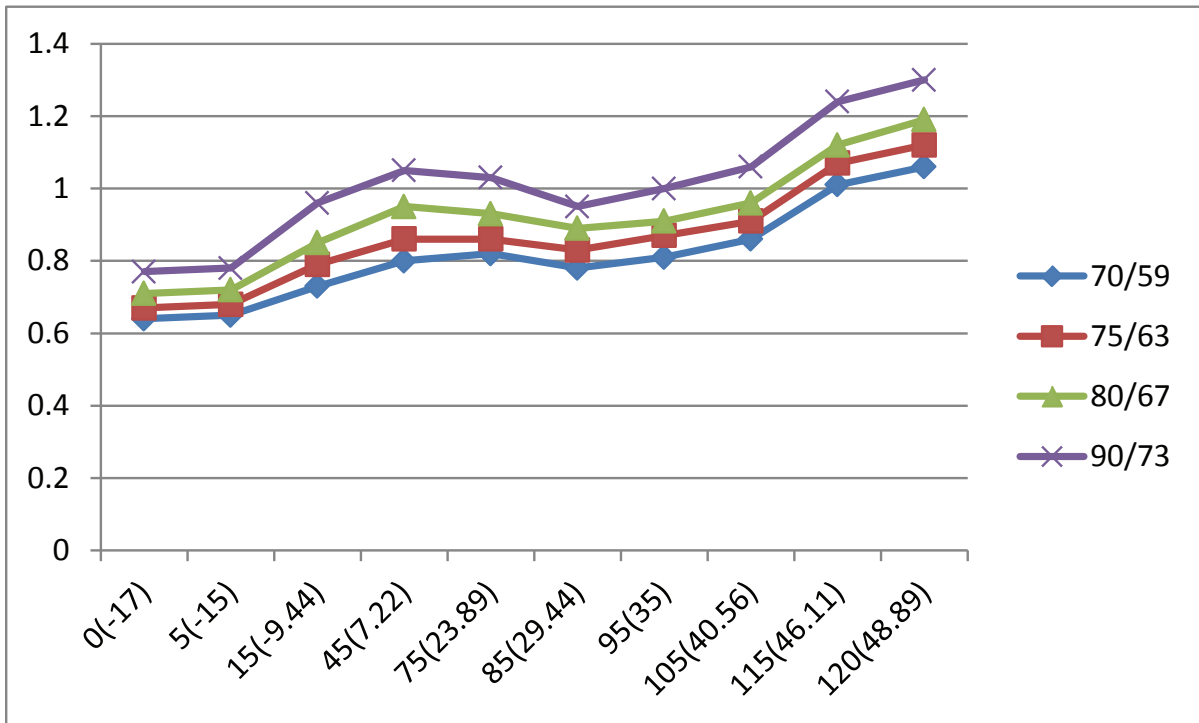

Heating chart(R410A):

°F(°C)	ODU(DB/WB)	57/53 (13.89/11.67)	47/43 (8.33/6.11)	37/33 (2.78/0.56)	27/23 (-2.78/-5)	17/13 (-8.33/ -10.56)	0/-2 (-17/-19)	-17/-18 (-27/-28)
	IDU(DB)							
BAR	55(12.78)	30.3	28.5	25.3	22.8	20.8	18.5	16.5
	65(18.33)	32.5	30.0	26.6	25.4	23.3	20.5	19.0
	75(23.89)	33.8	31.5	27.8	26.3	24.9	21.5	20.0
PSI	55(12.78)	439	413	367	330	302	268	239
	65(18.33)	471	435	386	368	339	297	276
	75(23.89)	489	457	403	381	362	312	290
MPa	55(12.78)	3.03	2.85	2.53	2.28	2.08	1.85	1.65
	65(18.33)	3.25	3.00	2.66	2.54	2.33	2.05	1.90
	75(23.89)	3.38	3.15	2.78	2.63	2.49	2.15	2.00

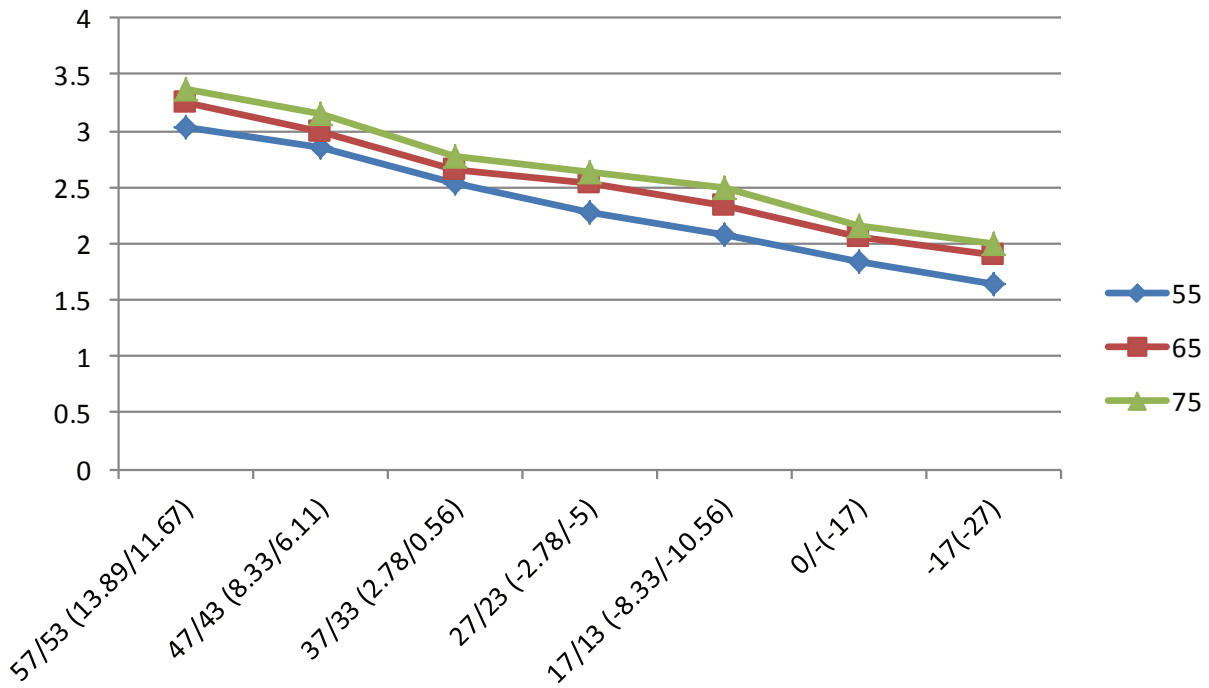

Cooling chart(R22):

°F(°C)	ODU(DB)		0(-17)	5(-15)	15(-9.44)	45(7.22)	75(23.89)	85(29.44)	95(35)	105(40.56)	115(46.11)	120(48.89)
	IDU(DB/WB)											
BAR	70/59 (21.11/15)		4.0	4.1	4.6	5.0	5.1	4.9	5.1	5.4	6.3	6.6
	75/63 (23.89/17.22)		4.2	4.3	4.9	5.4	5.4	5.2	5.4	5.7	6.7	7.0
	80/67 (26.67/19.44)		4.4	4.5	5.3	5.9	5.8	5.6	5.7	6.0	7.0	7.4
	90/73 (32.22/22.78)		4.8	4.9	6.0	6.6	6.4	5.9	6.3	6.6	7.8	8.1
PSI	70/59 (21.11/15)		58	59	67	73	74	71	74	78	91	96
	75/63 (23.89/17.22)		61	62	71	78	78	75	78	83	97	102
	80/67 (26.67/19.44)		64	65	77	86	84	81	83	87	102	107
	90/73 (32.22/22.78)		70	71	87	96	93	86	91	96	113	117
MPa	70/59 (21.11/15)		0.40	0.41	0.46	0.50	0.51	0.49	0.51	0.54	0.63	0.66
	75/63 (23.89/17.22)		0.42	0.43	0.49	0.54	0.54	0.52	0.54	0.57	0.67	0.70
	80/67 (26.67/19.44)		0.44	0.45	0.53	0.59	0.58	0.56	0.57	0.60	0.70	0.74
	90/73 (32.22/22.78)		0.48	0.49	0.60	0.66	0.64	0.59	0.63	0.66	0.78	0.81

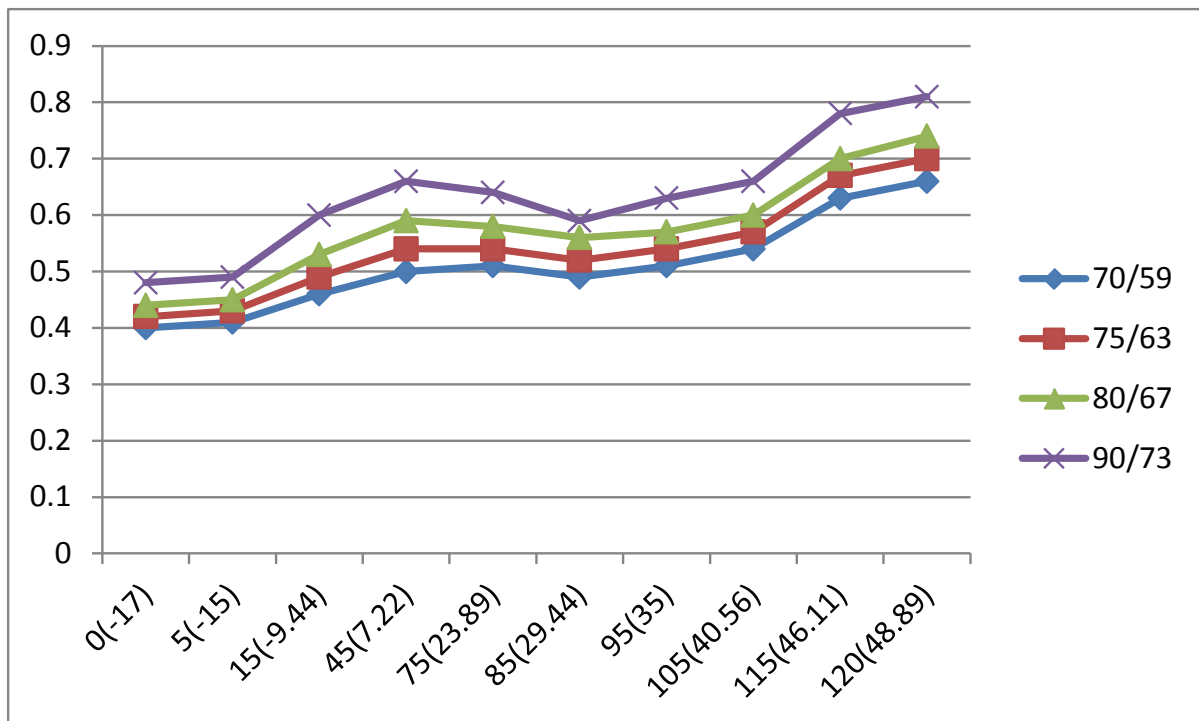

Heating chart(R22):

°F(°C)	ODU(DB/WB)	57/53 (13.89/11.67)	47/43 (8.33/6.11)	37/33 (2.78/0.56)	27/23 (-2.78/-5)	17/13 (-8.33/- 10.56)	0/-2 (-17/-19)	-17/-18 (-27/-28)
	IDU(DB)							
BAR	55(12.78)	18.9	17.8	15.8	14.3	13.0	11.6	10.3
	65(18.33)	20.3	18.8	16.6	15.9	14.6	12.8	11.9
	75(23.89)	21.1	19.7	17.3	16.4	15.6	13.4	12.5
PSI	55(12.78)	274	258	229	207	189	168	149
	65(18.33)	294	273	241	231	212	186	172.6
	75(23.89)	306	286	251	238	226	194	181
MPa	55(12.78)	1.89	1.78	1.58	1.43	1.30	1.16	1.03
	65(18.33)	2.03	1.88	1.66	1.59	1.46	1.28	1.19
	75(23.89)	2.11	1.97	1.73	1.64	1.56	1.34	1.25

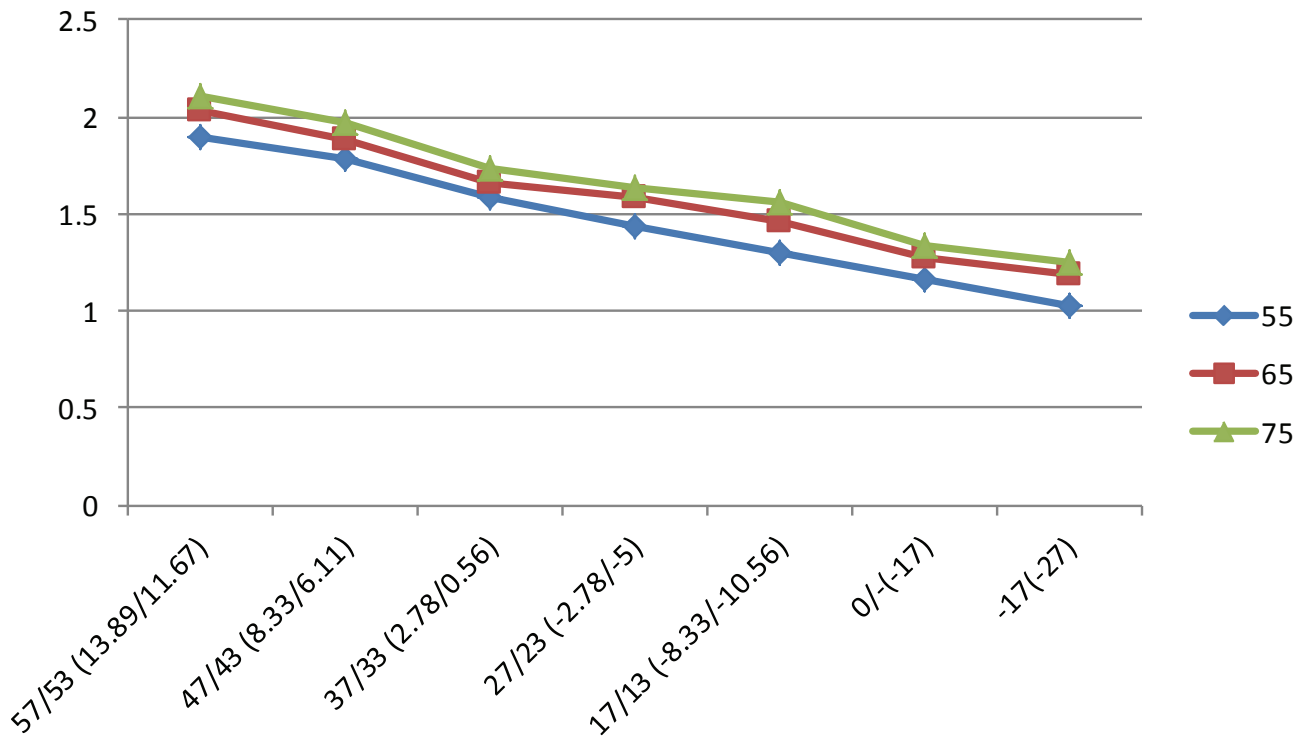

Cooling chart(R32):

°F(°C)	ODU(DB)		0(-17)	5(-15)	15(-9.44)	45(7.22)	75(23.89)	85(29.44)	95(35)	105(40.56)	115(46.11)	120(48.89)
	IDU(DB/WB)											
BAR	70/59 (21.11/15)		6.5	6.6	7.4	8.2	8.4	8.0	8.3	8.8	10.3	10.8
	75/63 (23.89/17.22)		6.8	6.9	8.1	8.8	8.8	8.5	8.9	9.3	10.9	11.4
	80/67 (26.67/19.44)		7.2	7.3	8.7	9.7	9.5	9.1	9.3	9.8	11.4	12.1
	90/73 (32.22/22.78)		7.9	8.0	9.8	10.7	10.5	9.7	10.2	10.8	12.6	13.3
PSI	70/59 (21.11/15)		95	96	108	118	121	115	119	128	150	157
	75/63 (23.89/17.22)		99	101	117	128	126	122	129	135	158	165
	80/67 (26.67/19.44)		105	106	125	141	138	132	135	143	165	176
	90/73 (32.22/22.78)		114	115	142	155	152	141	148	157	184	193
MPa	70/59 (21.11/15)		0.65	0.66	0.74	0.82	0.84	0.80	0.83	0.88	1.03	1.08
	75/63 (23.89/17.22)		0.68	0.69	0.81	0.88	0.88	0.85	0.89	0.93	1.09	1.14
	80/67 (26.67/19.44)		0.72	0.73	0.87	0.97	0.95	0.91	0.93	0.98	1.14	1.21
	90/73 (32.22/22.78)		0.79	0.80	0.98	1.07	1.05	0.97	1.02	1.08	1.26	1.33

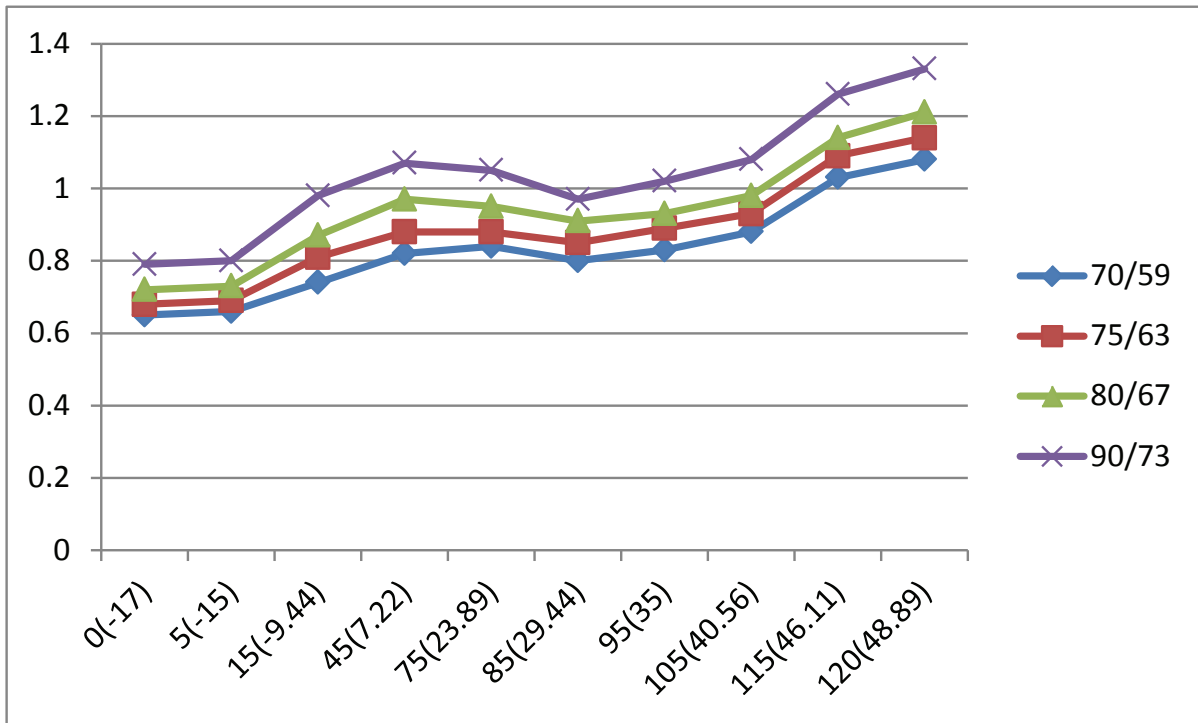

Heating chart(R32):

°F(°C)	ODU(DB/WB)	57/53 (13.89/11.67)	47/43 (8.33/6.11)	37/33 (2.78/0.56)	27/23 (-2.78/-5)	17/13 (-8.33/ -10.56)	0/-2 (-17/-19)	-17/-18 (-27/-28)
	IDU(DB)							
BAR	55(12.78)	30.9	29.1	25.8	23.3	21.2	18.9	16.8
	65(18.33)	33.2	30.6	27.1	25.9	23.8	20.9	19.4
	75(23.89)	34.5	32.1	28.4	26.8	25.4	21.9	20.4
PSI	55(12.78)	448	421	374	337	308	273	244
	65(18.33)	480	444	394	375	346	303	282
	75(23.89)	499	466	411	389	369	318	296
MPa	55(12.78)	3.09	2.91	2.58	2.33	2.12	1.89	1.68
	65(18.33)	3.32	3.06	2.71	2.59	2.38	2.09	1.94
	75(23.89)	3.45	3.21	2.84	2.68	2.54	2.19	2.04

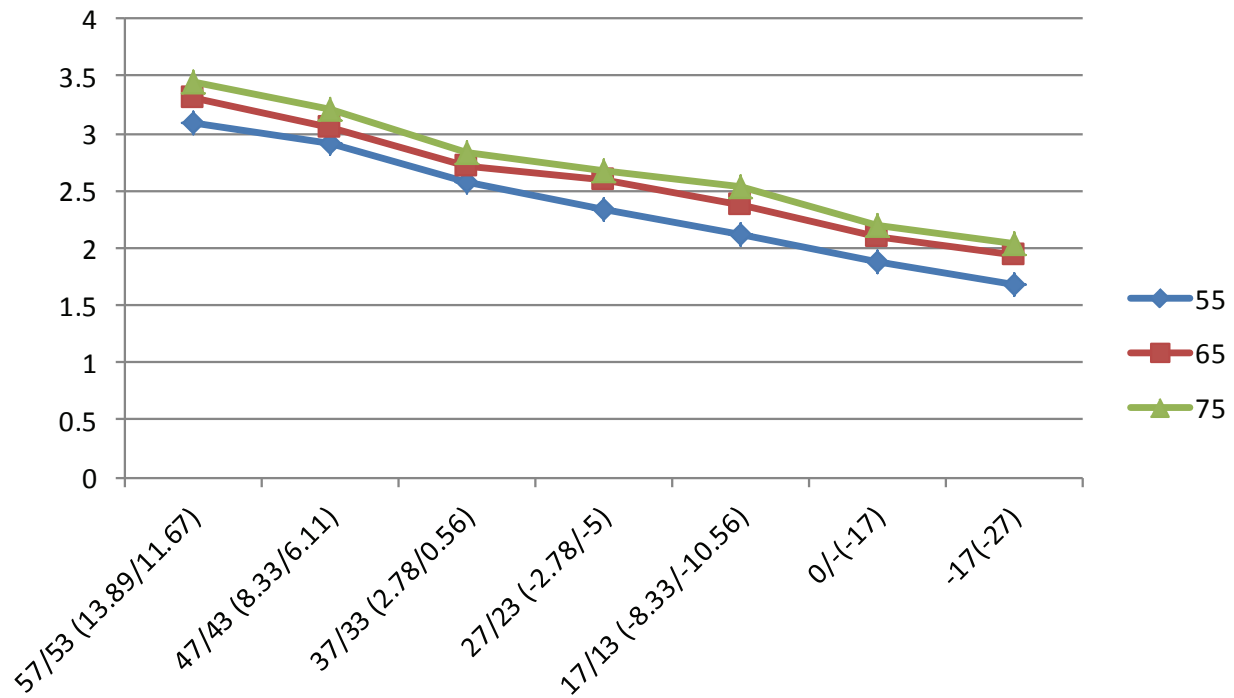

System Pressure Table-R22

Pressure			Temperature		Pressure			Temperature	
Kpa	bar	PSI	°C	°F	Kpa	bar	PSI	°C	°F
100	1	14.5	-41.091	-41.964	1600	16	232	41.748	107.146
150	1.5	21.75	-32.077	-25.739	1650	16.5	239.25	43.029	109.452
200	2	29	-25.177	-13.319	1700	17	246.5	44.281	111.706
250	2.5	36.25	-19.508	-3.114	1750	17.5	253.75	45.506	113.911
300	3	43.5	-14.654	5.623	1800	18	261	46.706	116.071
350	3.5	50.75	-10.384	13.309	1850	18.5	268.25	47.882	118.188
400	4	58	-6.556	20.199	1900	19	275.5	49.034	120.261
450	4.5	65.25	-3.075	26.464	1950	19.5	282.75	50.164	122.295
500	5	72.5	0.124	32.223	2000	20	290	51.273	124.291
550	5.5	79.75	3.091	37.563	2050	20.5	297.25	52.361	126.250
600	6	87	5.861	42.550	2100	21	304.5	53.43	128.174
650	6.5	94.25	8.464	47.234	2150	21.5	311.75	54.48	130.064
700	7	101.5	10.92	51.656	2200	22	319	55.512	131.922
750	7.5	108.75	13.249	55.848	2250	22.5	326.25	56.527	133.749
800	8	116	15.465	59.837	2300	23	333.5	57.526	135.547
850	8.5	123.25	17.58	63.644	2350	23.5	340.75	58.508	137.314
900	9	130.5	19.604	67.287	2400	24	348	59.475	139.055
950	9.5	137.75	21.547	70.785	2450	24.5	355.25	60.427	140.769
1000	10	145	23.415	74.147	2500	25	362.5	61.364	142.455
1050	10.5	152.25	25.216	77.389	2550	25.5	369.75	62.288	144.118
1100	11	159.5	26.953	80.515	2600	26	377	63.198	145.756
1150	11.5	166.75	28.634	83.541	2650	26.5	384.25	64.095	147.371
1200	12	174	30.261	86.470	2700	27	391.5	64.98	148.964
1250	12.5	181.25	31.839	89.310	2750	27.5	398.75	65.852	150.534
1300	13	188.5	33.371	92.068	2800	28	406	66.712	152.082
1350	13.5	195.75	34.86	94.748	2850	28.5	413.25	67.561	153.610
1400	14	203	36.308	97.354	2900	29	420.5	68.399	155.118
1450	14.5	210.25	37.719	99.894	2950	29.5	427.75	69.226	156.607
1500	15	217.5	39.095	102.371	3000	30	435	70.042	158.076
1550	15.5	224.75	40.437	104.787					

System Pressure Table-R410A

Pressure			Temperature		Pressure			Temperature	
Kpa	bar	PSI	°C	°F	Kpa	bar	PSI	°C	°F
100	1	14.5	-51.623	-60.921	2350	23.5	340.75	38.817	101.871
150	1.5	21.75	-43.327	-45.989	2400	24	348	39.68	103.424
200	2	29	-36.992	-34.586	2450	24.5	355.25	40.531	104.956
250	2.5	36.25	-31.795	-25.231	2500	25	362.5	41.368	106.462
300	3	43.5	-27.351	-17.232	2550	25.5	369.75	42.192	107.946
350	3.5	50.75	-23.448	-10.206	2600	26	377	43.004	109.407
400	4	58	-19.953	-3.915	2650	26.5	384.25	43.804	110.847
450	4.5	65.25	-16.779	1.798	2700	27	391.5	44.592	112.266
500	5	72.5	-13.863	7.047	2750	27.5	398.75	45.37	113.666
550	5.5	79.75	-11.162	11.908	2800	28	406	46.136	115.045
600	6	87	-8.643	16.444	2850	28.5	413.25	46.892	116.406
650	6.5	94.25	-6.277	20.701	2900	29	420.5	47.638	117.748
700	7	101.5	-4.046	24.716	2950	29.5	427.75	48.374	119.073
750	7.5	108.75	-1.933	28.521	3000	30	435	49.101	120.382
800	8	116	0.076	32.137	3050	30.5	442.25	49.818	121.672
850	8.5	123.25	1.993	35.587	3100	31	449.5	50.525	122.945
900	9	130.5	3.826	38.888	3150	31.5	456.75	51.224	124.203
950	9.5	137.75	5.584	42.052	3200	32	464	51.914	125.445
1000	10	145	7.274	45.093	3250	32.5	471.25	52.596	126.673
1050	10.5	152.25	8.901	48.022	3300	33	478.5	53.27	127.886
1100	11	159.5	10.471	50.848	3350	33.5	485.75	53.935	129.083
1150	11.5	166.75	11.988	53.578	3400	34	493	54.593	130.267
1200	12	174	13.457	56.223	3450	34.5	500.25	55.243	131.437
1250	12.5	181.25	14.879	58.782	3500	35	507.5	55.885	132.593
1300	13	188.5	16.26	61.268	3550	35.5	514.75	56.52	133.736
1350	13.5	195.75	17.602	63.684	3600	36	522	57.148	134.866
1400	14	203	18.906	66.031	3650	36.5	529.25	57.769	135.984
1450	14.5	210.25	20.176	68.317	3700	37	536.5	58.383	137.089
1500	15	217.5	21.414	70.545	3750	37.5	543.75	58.99	138.182
1550	15.5	224.75	22.621	72.718	3800	38	551	59.591	139.264
1600	16	232	23.799	74.838	3850	38.5	558.25	60.185	140.333
1650	16.5	239.25	24.949	76.908	3900	39	565.5	60.773	141.391
1700	17	246.5	26.074	78.933	3950	39.5	572.75	61.355	142.439
1750	17.5	253.75	27.174	80.913	4000	40	580	61.93	143.474
1800	18	261	28.251	82.852	4050	40.5	587.25	62.499	144.498
1850	18.5	268.25	29.305	84.749	4100	41	594.5	63.063	145.513
1900	19	275.5	30.338	86.608	4150	41.5	601.75	63.62	146.516
1950	19.5	282.75	31.351	88.432	4200	42	609	64.172	147.510
2000	20	290	32.344	90.219	4250	42.5	616.25	64.719	148.494
2050	20.5	297.25	33.319	91.974	4300	43	623.5	65.259	149.466
2100	21	304.5	34.276	93.697	4350	43.5	630.75	65.795	150.431
2150	21.5	311.75	35.215	95.387	4400	44	638	66.324	151.383
2200	22	319	36.139	97.050	4450	44.5	645.25	66.849	152.328
2250	22.5	326.25	37.047	98.685	4500	45	652.5	67.368	153.262
2300	23	333.5	37.939	100.290					

System Pressure Table-R32

Pressure			Temperature		Pressure			Temperature	
Kpa	bar	PSI	°C	°F	Kpa	bar	PSI	°C	°F
100	1	14.5	-51.909	-61.436	1850	18.5	268.25	28.425	83.165
150	1.5	21.75	-43.635	-46.543	1900	19	275.5	29.447	85.005
200	2	29	-37.323	-35.181	1950	19.5	282.75	30.448	86.806
250	2.5	36.25	-32.15	-25.87	2000	20	290	31.431	88.576
300	3	43.5	-27.731	-17.916	2050	20.5	297.25	32.395	90.311
350	3.5	50.75	-23.85	-10.93	2100	21	304.5	33.341	92.014
400	4	58	-20.378	-4.680	2150	21.5	311.75	34.271	93.688
450	4.5	65.25	-17.225	0.995	2200	22	319	35.184	95.331
500	5	72.5	-14.331	6.204	2250	22.5	326.25	36.082	96.948
550	5.5	79.75	-11.65	11.03	2300	23	333.5	36.965	98.537
600	6	87	-9.150	15.529	2350	23.5	340.75	37.834	100.101
650	6.5	94.25	-6.805	19.752	2400	24	348	38.688	101.638
700	7	101.5	-4.593	23.734	2450	24.5	355.25	39.529	103.152
750	7.5	108.75	-2.498	27.505	2500	25	362.5	40.358	104.644
800	8	116	-0.506	31.089	2550	25.5	369.75	41.173	106.111
850	8.5	123.25	1.393	34.507	2600	26	377	41.977	107.559
900	9	130.5	3.209	37.777	2650	26.5	384.25	42.769	108.984
950	9.5	137.75	4.951	40.911	2700	27	391.5	43.55	110.39
1000	10	145	6.624	43.923	2750	27.5	398.75	44.32	111.776
1050	10.5	152.25	8.235	46.823	2800	28	406	45.079	113.142
1100	11	159.5	9.790	49.621	2850	28.5	413.25	45.828	114.490
1150	11.5	166.75	11.291	52.324	2900	29	420.5	46.567	115.821
1200	12	174	12.745	54.941	2950	29.5	427.75	47.296	117.133
1250	12.5	181.25	14.153	57.475	3000	30	435	48.015	118.427
1300	13	188.5	15.52	59.936	3050	30.5	442.25	48.726	119.707
1350	13.5	195.75	16.847	62.325	3100	31	449.5	49.428	120.970
1400	14	203	18.138	64.648	3150	31.5	456.75	50.121	122.218
1450	14.5	210.25	19.395	66.911	3200	32	464	50.806	123.451
1500	15	217.5	20.619	69.114	3250	32.5	471.25	51.482	124.668
1550	15.5	224.75	21.813	71.263	3300	33	478.5	52.15	125.87
1600	16	232	22.978	73.360	3350	33.5	485.75	52.811	127.060
1650	16.5	239.25	24.116	75.409	3400	34	493	53.464	128.235
1700	17	246.5	25.229	77.412	3450	34.5	500.25	54.11	129.398
1750	17.5	253.75	26.317	79.371	3500	35	507.5	54.748	130.546
1800	18	261	27.382	81.288					

Due to ongoing product improvements, specifications and dimensions are subject to change and correction without notice or incurring obligations. Determining the application and suitability for use of any product is the responsibility of the installer. Additionally, the installer is responsible for verifying dimensional data on the actual product prior to beginning any installation preparations.

Incentive and rebate programs have precise requirements as to product performance and certification. All products meet applicable regulations in effect on date of manufacture; however, certifications are not necessarily granted for the life of a product. Therefore, it is the responsibility of the applicant to determine whether a specific model qualifies for these incentive/rebate programs.



1900 Wellworth Ave., Jackson, MI 49203 • Ph. 517-787-2100 • www.heatcontroller.com